

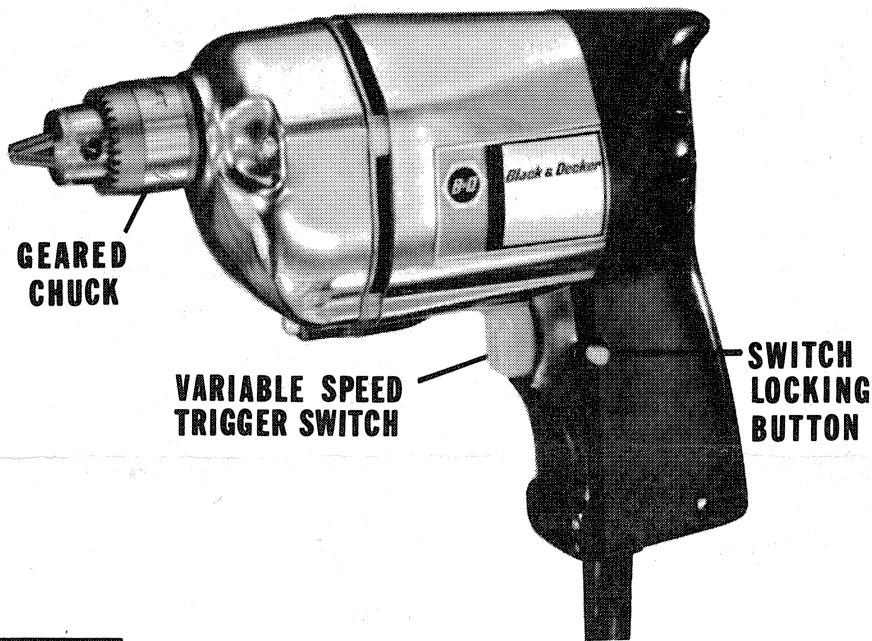

Black & Decker

OWNER'S MANUAL



1/4" DRILL #6002

VARIABLE SPEED SWITCH
0 to 2250 R.P.M. Capacity: 1/4" holes in steel; 1/2" in hardwood. 120 Volts A.C. 2 Amps. 1/7 H.P.

3/8" DRILL #6022

VARIABLE SPEED SWITCH
0 to 1000 R.P.M. Capacity: 3/8" holes in steel; 3/4" in hardwood. 120 Volts A.C. 2.4 Amps. 1/7 H.P.

IMPORTANT INFORMATION



Safety Rules for Power Tools

The use of the Safety Seal of the Power Tool Institute assures you that this tool is produced and tested in accordance with applicable national safety standards. Operational safety, however, depends to a great extent upon the user of the tool. Please pay close attention to the following rules.

1. **KNOW YOUR POWER TOOL** — Read owner's manual carefully. Learn its applications and limitations as well as the specific potential hazards peculiar to this tool.
2. **GROUND ALL TOOLS — UNLESS DOUBLE-INSULATED.** If tool is equipped with three-prong plug, it should be plugged into a three-hole electrical receptacle. If adapter is used to accommodate two-prong receptacle, the adapter wire must be attached to a **known ground.** Never remove third prong.
3. **KEEP WORK AREA CLEAN.** Cluttered areas and benches invite accidents.
4. **AVOID DANGEROUS ENVIRONMENT.** Don't expose power tools to rain. Don't use power tool in damp or wet locations. And keep work area well lit.
5. **KEEP CHILDREN AWAY.** All visitors should be kept safe distance from work area.
6. **STORE IDLE TOOLS.** When not in use, tools should be stored in dry, high or locked-up place — out of reach of children.
7. **DON'T FORCE TOOL.** It will do the job better and safer at the rate for which it was designed.
8. **USE RIGHT TOOL.** Don't force small tool or attachment to do the job of a heavy duty tool.
9. **WEAR PROPER APPAREL.** No loose clothing or jewelry to get caught in moving parts. Rubber gloves and footwear are recommended when working outdoors.
10. **USE SAFETY GLASSES** with most tools. Also face or dust mask if cutting operation is dusty.
11. **DON'T ABUSE CORD.** Never carry tool by cord or yank it to disconnect from receptacle. Keep cord from heat, oil and sharp edges.
12. **SECURE WORK.** Use clamps or a vise to hold work. It's safer than using your hand and it frees both hands to operate tool.
13. **DON'T OVERREACH.** Keep proper footing and balance at all times.
14. **MAINTAIN TOOLS WITH CARE.** Keep tools sharp at all times, and clean for best and safest performance. Follow instructions for lubricating and changing accessories.
15. **DISCONNECT TOOLS.** When not in use, before servicing; when changing accessories such as blades, bits, cutters, etc.
16. **REMOVE ADJUSTING KEYS AND WRENCHES.** Form habit of checking to see that keys and adjusting wrenches are removed from tool before turning it on.
17. **AVOID ACCIDENTAL STARTING.** Don't carry plugged-in tool with finger on switch. Be sure switch is off when plugging in.
18. **OUTDOOR USE EXTENSION CORDS.** When tool is used outdoors, use only extension cords suitable for use outdoors and so marked.

IMPORTANT INFORMATION

Grounding

This tool should be grounded while in use to protect the operator from electric shock. The tool is equipped with an approved three-conductor cord and three-prong grounding type plug to fit the proper grounding type receptacle. The green (or green and yellow) conductor in the cord is the grounding wire. Never connect the green (or green and yellow) wire to a live terminal. If your unit is for use on less than 150 volts, it has a plug like that shown in Figure A. If it is for use on 150 to 250 volts, it has a plug like that shown in Figure D. An adapter, Figures B and C, is available for connecting Figure A plugs to two-prong receptacles. The green-colored rigid ear, lug, etc., must be connected to a permanent ground such as a properly grounded outlet box. No adapter is available for a plug as shown in Figure D.

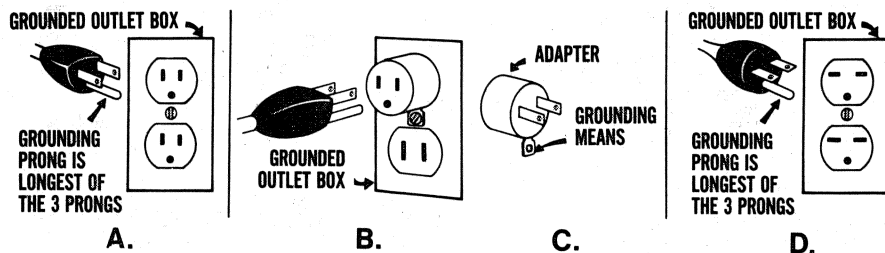

We recommend that you NEVER disassemble the tool or try to do any rewiring in the electrical system. Any such repairs should be performed only by B&D Service Centers or other qualified service organizations. Should you be determined to make a repair yourself, remember that the green colored wire is the "grounding" wire. Never connect this green wire to a "live" terminal. If you replace the plug on the power cord, be sure to connect the green wire only to the grounding (longest) prong on a 3-prong plug.

If you use an extension cord, be sure that it is a 3-conductor, grounding type cord. Grounding must be continuous from the tool plug to the grounded receptacle.

EXTENSION CORD

When using this drill at a considerable distance from power source, a 3-conductor, grounding-type extension cord of adequate size must be used for safety, and to prevent loss of power and over-heating. For a 120-volt tool, the minimum size of the wires in any extension cord up to 75 feet long must be 18-gauge (American Wire Gauge). If the total extension cord length is from 75 to 100 feet, 16-gauge wire is required throughout the extension. 200-volt tools require a minimum wire size of only 18-gauge in extension cord lengths up to 200 feet long. (NOTE: 16-gauge wire is heavier than 18-gauge wire and will carry current for longer distances without a voltage drop.)

Use only three wire extension cords which have three-prong grounding-type plugs and three-pole receptacles which accept the tool's plug. Replace or repair damaged cords.

LUBRICATION

Self lubricating bearings are used in the tool and periodic relubrication is not required. However, it is recommended that, once a year, you take or send the tool to a B&D Service Center for a thorough cleaning, inspection and lubrication of the gear case.

OPERATION

Drilling in Metal

Use a cutting lubricant when drilling metals. The exceptions are cast iron and brass which should be drilled dry. The cutting lubricants that work best are sulphurized cutting oil or lard oil; bacon grease will also serve the purpose. Aluminum is best drilled with kerosene.

Drilling in Wood

Holes in wood can be made with the same twist drills used for metal. These bits may overheat unless pulled out frequently to clear chips from the flutes. For larger holes, use Power Drill Wood Bits. Work that is apt to splinter should be backed up with a block of wood. Let up on the pressure just before the tip cuts through, this will give a good clean hole. Always leave the drill running when pulling it back out of a drilled hole, this prevents jamming.

Accessories

Recommended accessories for use with your Drill are shown below and in Black & Decker catalogs (CAUTION: The use of any other accessory might be more hazardous). For safety in use, the following accessories should be used only in the sizes specified below:

BITS, METAL DRILLING — Up to 1/4" with 1/4" DRILL; up to 3/8" with 3/8" DRILL.

BITS, MASONRY DRILLING — Up to 1/2".

BITS, WOOD DRILLING — Up to 1/2" with 1/4" DRILL; up to 3/4" with 3/8" DRILL.

HOLE SAWS — Up to 1 1/8" with 1/4" DRILL; up to 1 1/2" with 3/8" DRILL.

WIRE BRUSHES — Up to 3" diameter.

BUFFING WHEELS — Up to 4" diameter.

BACKING PADS — 4 5/8" diameter.

We strongly recommend that your first purchase be Safety Glasses which should be worn when using all drill accessories.

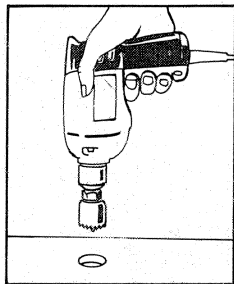

HOLE SAWS will cut larger diameter holes in wood up to 3/4" thick.

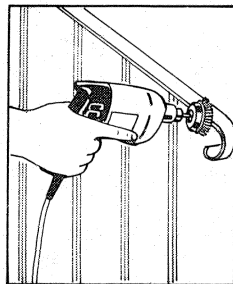

WIRE CUP BRUSH removes rust, scale, and old paint from metal surfaces.

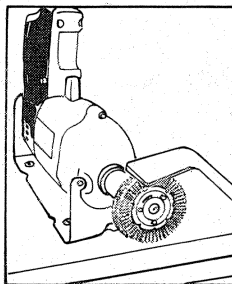

3" WIRE WHEEL BRUSHES clean metal, remove rust and paint.

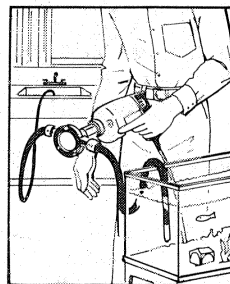

DRILL PUMP uses 2 pcs. of garden hose. Non-flammable liquids only.

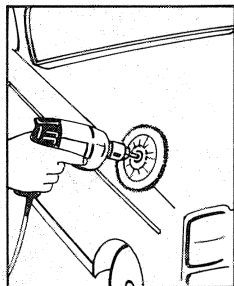

POLISHING BONNETS. For cleaning, polishing, waxing of cars, floors, etc.

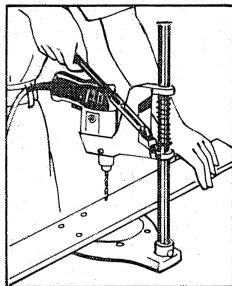

BENCH DRILL STAND permits steady, vertical drilling for accurate work.

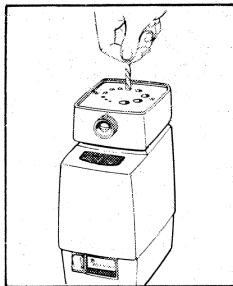

DRILL BIT SHARPENER enables you to extend the useful life of your drill bits.



PAINT MIXER. Thoroughly mixes paint in up to 1-gal. cans. Fast, easy.



SAFETY GLASSES Lightweight, clear plastic with side shields. Wear alone or over regular glasses.

OPERATION

Switch

The Variable Speed Trigger Switch permits "FREE HAND" speed control — the farther the trigger is depressed, the higher the speed of the Drill. A Switch Locking Button permits locking the trigger in the full "ON" position for continuous operation. To lock the trigger "ON," depress trigger fully and push in locking button, then gently release trigger. To release locking mechanism, depress trigger fully, then release it.

NOTE: Use lower speeds for STARTING HOLES WITHOUT A CENTER PUNCH, DRILLING IN METAL OR PLASTICS, DRIVING SCREWS, DRILLING CERAMICS, OR MIXING PAINT. Higher speeds are better for DRILLING WOOD AND COMPOSITION BOARDS, AND FOR USING ABRASIVE AND POLISHING ACCESSORIES.

Do not lock the switch "ON" when drilling by hand so that you can instantly release the trigger switch if the bit binds in the hole.

Be sure to release the switch locking button before disconnecting the plug from the power supply. Failure to do so will cause the tool to start immediately the next time it is plugged in. Damage or injury could occur.

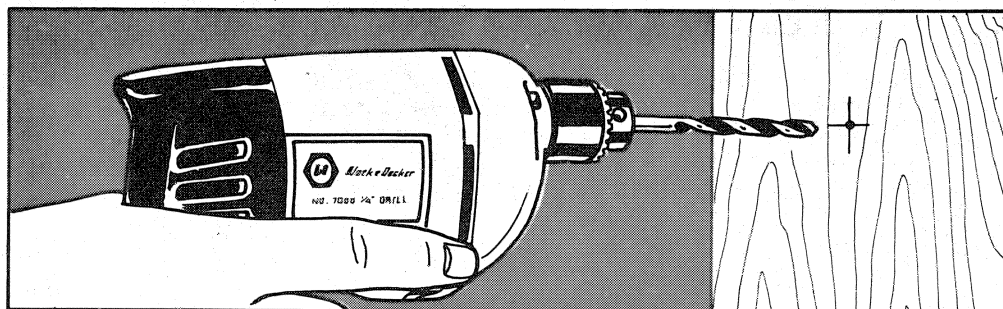

Drilling

1. Always unplug the Drill when attaching or changing bits or accessories.
2. Use sharp drill bits only. For WOOD, use twist drill bits, spade bits, power auger bits, or hole saws. For METAL, use high-speed steel twist drill bits or hole saws. For MASONRY, such as brick, cement, cinder block, etc., use carbide-tipped bits.
3. Be sure the material to be drilled is anchored or clamped firmly. If drilling thin material, use a wood "back-up" block to prevent damage to the material.
4. With Variable Speed Drills there is no need to center punch the point to be drilled. Use a slow speed to start the hole and accelerate by squeezing the trigger harder when the hole is deep enough to drill without the bit skipping out.
5. Always apply pressure in a straight line with the bit. Use enough pressure to keep drill biting, but do not push hard enough to stall the motor or deflect the bit.
6. Hold drill firmly to control the twisting action of the drill.
7. IF DRILL STALLS, it is usually because it is being overloaded or improperly used. RELEASE TRIGGER IMMEDIATELY, remove drill bit from work, and determine cause of stalling. DO NOT CLICK TRIGGER OFF AND ON IN AN ATTEMPT TO START A STALLED DRILL — THIS CAN DAMAGE THE DRILL.
8. To minimize stalling on breaking through the material, reduce pressure on drill and ease the bit through the last fractional part of the hole. Keep the motor running when pulling the bit back out of a drilled hole. This will help prevent jamming.

Chuck

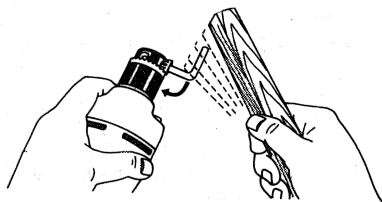
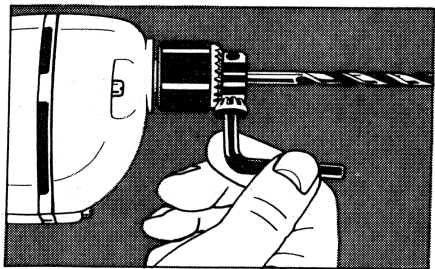

UNPLUG DRILL. Open chuck jaws by turning collar with fingers and insert shank of bit about $\frac{3}{4}$ " into chuck. Tighten chuck collar by hand. Place chuck key in each of the three holes, and tighten in clockwise direction. It's important to tighten chuck with all three holes. To release bit, turn chuck key counterclockwise in just one hole, then loosen chuck by hand.

To remove the chuck from the Drill, for using a threaded shank accessory or for chuck replacement, first unplug the tool. Insert the key in the chuck and tap it sharply in the direction the tool normally rotates — see at left. This will loosen the chuck shank threads and the chuck may be unscrewed by hand.

MAINTENANCE

If The Tool Does Not Run

First, check your electric outlet by plugging in another tool or lamp. If either of these doesn't work, check for blown fuses. If current is present, check plugs and sockets for tight connections. If the tool still won't run, take or send it to a Black & Decker Service Center for checking and repair. Do not attempt any major repair on your own.

Lubrication

Self lubricating bearings are used in the tool and periodic relubrication is not required. However, it is recommended that, at least once a year, you take or send the tool to a B&D Service Center for a thorough cleaning, inspection and lubrication of the gear case.

Cleaning

UNPLUG DRILL. Use a rag dampened only with mild soap and hot water. Many household cleaners contain chemicals which could seriously damage the plastic handle. **DO NOT** let any water get inside the tool.

Guarantee

Black & Decker guarantees, for one year from date of purchase, to correct by repair or parts replacement without charge any defect due to faulty material or workmanship. Simply return the complete unit, transportation prepaid, to any Black & Decker Service Center or Authorized Service Station. Naturally, we assume no responsibility for damage caused by misuse, careless handling or where repairs have been made or attempted by others. No other guarantee, written or verbal, is authorized by us.

Important!

To assure product **SAFETY** and **RELIABILITY**, repairs, maintenance and adjustment (including brush inspection and replacement), should be performed by Black & Decker Service Centers or other qualified service organizations, always using Black & Decker replacement parts.



THE BLACK & DECKER MFG. CO.
Towson, Md. 21204, U.S.A.