

PARTS LIST

POWER AUGER

AG4300
AG531

NOTE :

1. Use ZENOAH genuine parts specified in the parts list for repair and/or replacement.
2. ZENOAH does not warrant the machines, those which have been damaged by the use of any parts other than those specified by the company.
3. When placing orders of parts for repair and/or replacement, check if the model name and the serial number are suitable to those specified in the parts list, then use parts number described in the parts list.
4. The contents described in the parts list may change due to improvement.
5. The parts for the machine shall be supplied within ten (10) years after the machine is discontinued.
[It is possible that some specific parts may be subject to change of their delivery term and list price within the limit of ten (10) years after the machine is discontinued. And it is also possible that some parts may be available even after the limit of ten (10) years.]

APPLICABLE SERIAL NUMBERS

AG43108, GA41011 : 000101 and up
AG53005, GA50125 : 100101 and up

June 2005

AG4300/AG531

Fig.1 FRAME and GEARCASE

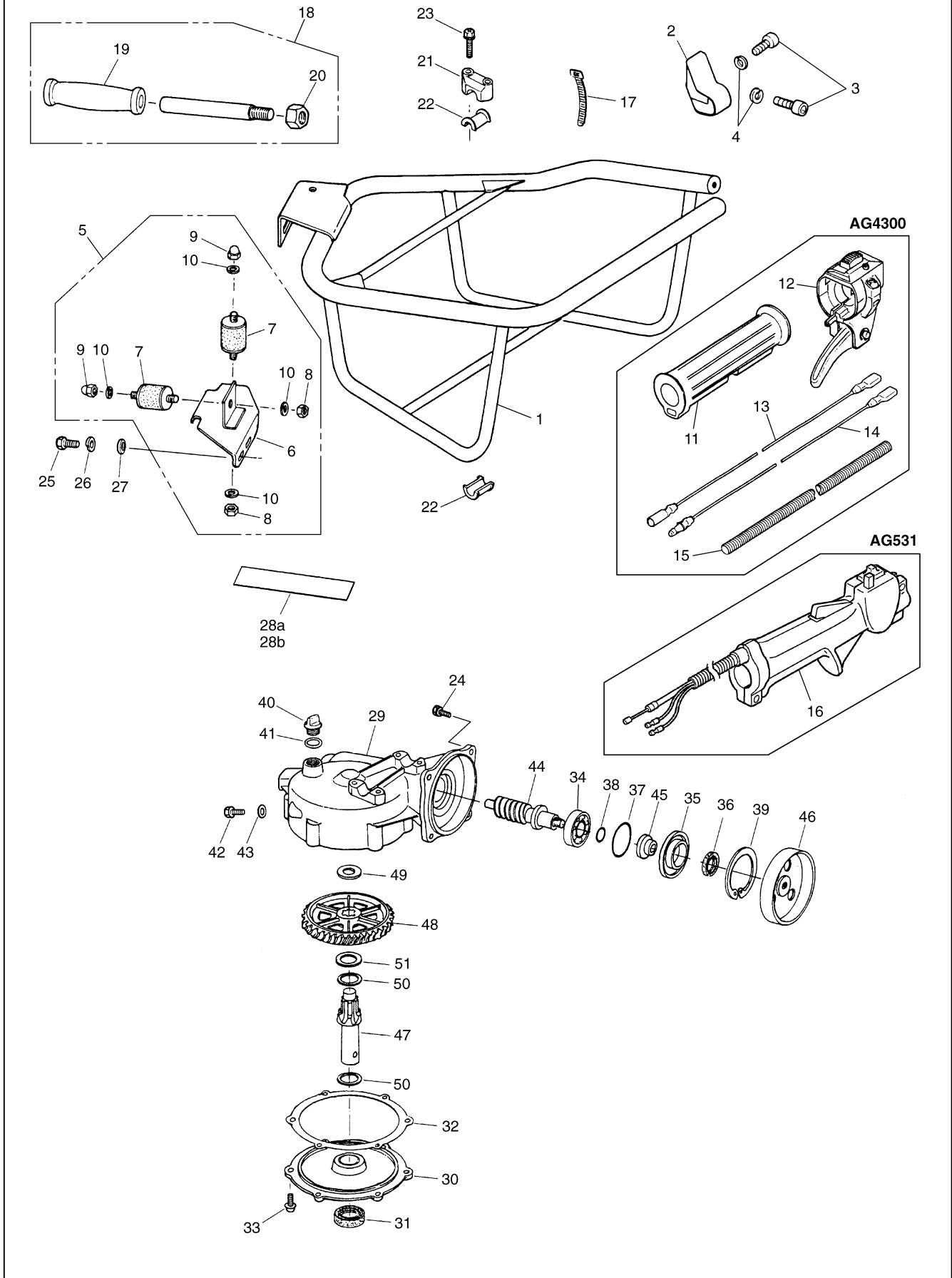

Fig.1 FRAME and GEARCASE

Key#	PART NUMBER	DESCRIPTION	Q'TY /UNIT	NOTE	Key#	PART NUMBER	DESCRIPTION	Q'TY /UNIT	NOTE
1	T4502-31110	FRAME	1		45	3200-21121	COLLOR	1	
2	T4502-31 120	BRACKET, frame	1		46	3200-21130	DRUM	1	
3	01252-31025	BOLT	2	M10x25	47	3206-21210	SHAFT	1	
4	01602-21030	WASHER	2		48	3205-21220	WHEEL	1	
5	3206-31202	BRACKET ASS'Y	1		49	3200-21230	WASHER	1	
6	3206-31212	• BRACKET	1		50	3202-21240	WASHER	2	
7	3206-31220	• MOUNT	2		51	3200-21250	SHIM	0-3	
8	0280-10605	• NUT	2	M6					
9	1000-15150	• NUT	2	M6					
10	0290-20615	• WASHER	4						
11	3577-32141	GRIP	1	AG4300					
12	8488R20313	LEVER	1	AG4300					
13	T4502-73220	CORD	1	AG4300					
14	T4502-73230	CORD	1	AG4300					
15	T4502-73240	TUBE	1	AG4300					
16	T1137-84000	LEVER COMP.	1	AG531					
17	3540-93120	BAND	1						
18	3204-31300	HANDLE COMP.	1						
19	4050-14220	• GRIP	1						
20	0281-11411	• NUT	1	M14					
21	3209-31123	HOLDER	2						
22	3206-31130	SPACER	4						
23	0225-50630	BOLT	4	M6x30					
24	6468-91150	BOLT	4	M6x20					
25	01010-80620	BOLT	2	M6x20					
26	01602-20619	WASHER	2	M6					
27	01643-30623	WASHER	2						
28a	T4502-12510	PLATE, name	1	AG4300					
28b	T4511-12510	PLATE, name	1	AG531					
29	3209-11103	GEARCASE COMP.	1						
30	3209-11203	COVER COMP.	1						
31	1800-21281	OIL SEAL	1						
32	3202-11260	GASKET	1						
33	0260-30620	SCREW	6	M6x20					
34	06000-06304	BEARING	1						
35	3202-11311	RETAINER	1						
36	3202-11320	OIL SEAL	1						
37	3200-11330	O-RING	1						
38	07000-02012	O-RING	1						
39	04065-06220	SNAP RING	1	ø62					
40	3202-11361	PLUG	1						
41	2510-23230	O-RING	1						
42	0224-40610	BOLT	1	M6x10					
43	3010-31380	GASKET	1						
44	3205-21110	WORM	1						

Fig.2 ENGINE

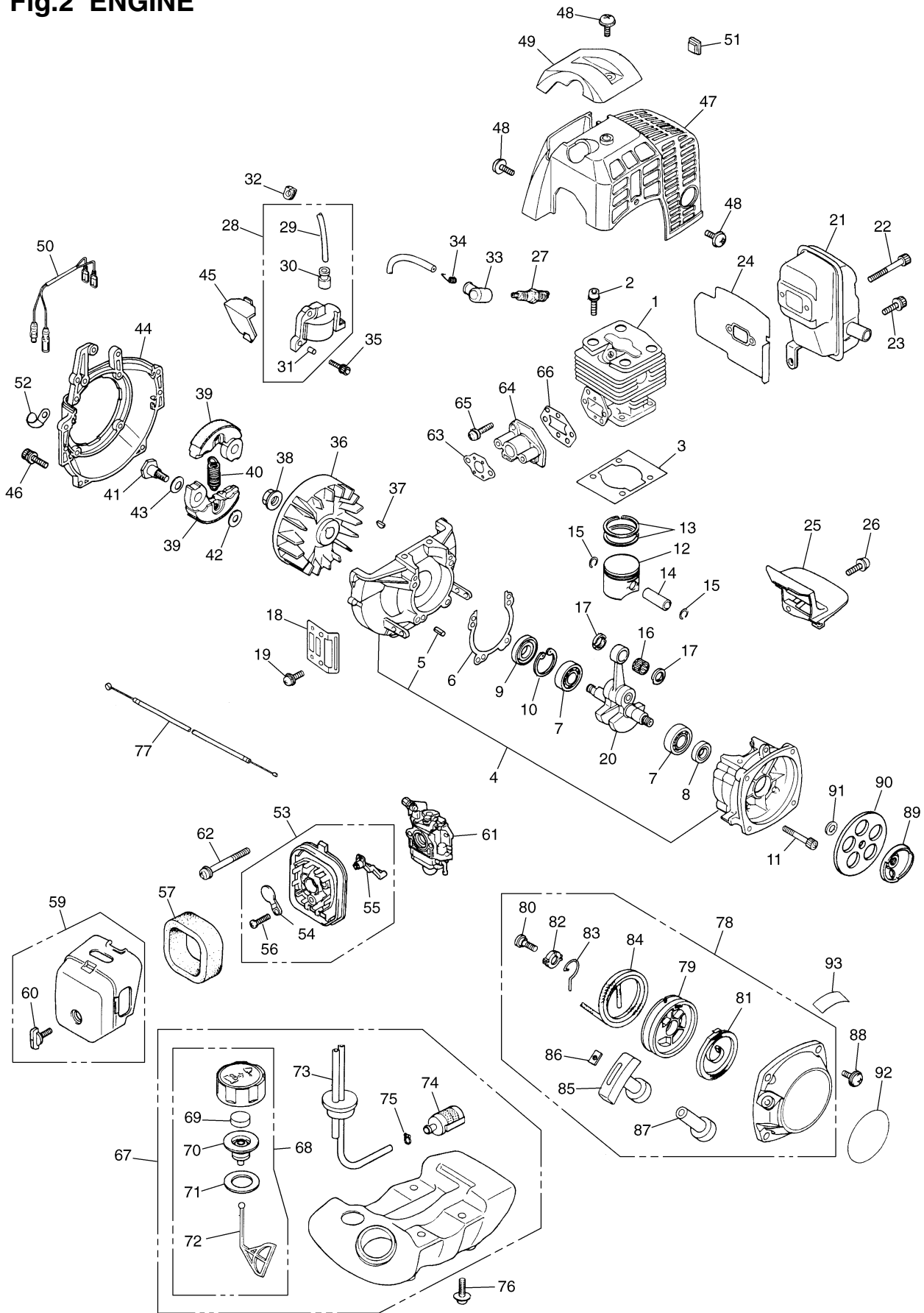

Fig.2 ENGINE

Key#	PART NUMBER	DESCRIPTION	Q'TY /UNIT	NOTE	Key#	PART NUMBER	DESCRIPTION	Q'TY /UNIT	NOTE
1	4500-12110	CYLINDER	1		53	T1184-82101	BODY ASS'Y	1	
2	1850-12130	BOLT	4	M5x22	54	T1184-82130	• PLATE, choke	1	
3	4500-13120	GASKET, base	1		55	4500-82140	• LEVER, choke	1	
4	4500-21101	CRANKCASE COMP.	1		56	2630-33610	• SCREW	1	
5	2629-21130	• PIN	3		57	4500-82170	ELEMENT	1	
6	4500-21140	GASKET, case	1		59	4500-82202	COVER ASS'Y	1	
7	06030-06201	BEARING	2		60	5500-82221	• KNOB	1	
8	4810-21210	OIL SEAL	1		61	4500-81001	CARBURETOR ASS'Y	1	WYK-93
9	1650-21220	OIL SEAL	1		62	0263-90550	SCREW	2	M5x50
10	04065-03212	SNAP RING	1	ø32	63	4500-13130	GASKET, carburetor	4	
11	01252-30530	BOLT	4	M5x30	64	4500-13161	INSULATOR	1	
12	4500-41110	PISTON	1		65	4500-13181	SCREW	2	M5x20
13	1400-41220	RING	2		66	4500-13150	GASKET, insulator	1	
14	2850-41310	PIN	1		67	T1015-85004	TANK ASS'Y	1	
15	1300-41320	RING	2		68	T1015-85202	• CAP ASS'Y	1	
16	T2100-41410	BEARING	1		69	5601-85260	•• FILTER	1	
17	2850-41510	WASHER	2		70	4500-85300	•• HOLDER ASS'Y	1	
18	4500-22110	GUARD	1		71	4500-85220	•• PACKING	1	
19	0263-90514	SCREW	1	M5x14	72	4820-85260	•• STOPPER	1	
20	4500-42000	CRANKSHAFT COMP.	1		73	T1015-85300	• PIPE COMP.	1	
21	4500-15110	MUFFLER	1		74	3302-85400	• FILTER ASS'Y	1	
22	01252-30565	BOLT	2	M5x65	75	1260-85460	• CLIP	1	
23	3310-31720	BOLT	1	M5x14	76	1600-86120	SCREW	4	M5x22
24	4700-15211	GASKET	1		77	T4502-83100	CABLE COMP.	1	
25	4500-15221	PLATE	1		78	T1123-75100	RECOIL ASS'Y	1	
26	0263-90514	SCREW	1	M5x14	79	4500-75120	• REEL	1	
27	3699-90332	SPARKPLUG NGK	1	BPMR7A	80	4500-75150	• SCREW	1	
28	4500-71200	COIL ASS'Y	1		81	1850-75130	• SPRING, spiral	1	
29	4500-71220	• CORD	1		82	4500-75180	• COLLOR	1	
30	2616-71320	• CAP	1		83	4500-75190	• ARM	1	
31	3356-21130	• PIN	2		84	4500-75160	• ROPE	1	
32	5500-72130	GROMMET	1		85	1140-75320	• KNOB	1	
33	5500-72110	CAP, plug	1		86	5500-75170	• PLATE	1	
34	1900-72120	SPRING	1		87	1410-75510	• ADAPTER	1	
35	4500-72150	BOLT	2	M4x22	88	4500-75511	SCREW	4	M6x14
36	4500-71110	ROTOR	1		89	4500-75210	PULLEY	1	
37	1000-43240	KEY	1		90	4500-75310	PLATE	1	
38	1650-43230	NUT	1	M8	91	01643-30823	WASHER	1	
39	4500-51111	SHOE, clutch	2		92	T1123-75410	LABEL, recoil	1	
40	4500-51220	SPRING	1		93	5604-91190	LABEL, caution	1	
41	1200-51211	SCREW	2	M8					
42	1200-51230	WASHER	2						
43	1200-51241	WASHER	2						
44	4500-31110	COVER, fan	1						
45	4500-31210	PLATE	1						
46	3310-12281	BOLT	4	M5x20					
47	4500-32110	COVER, cylinder	1						
48	4500-32120	SCREW	4	M5x12					
49	4500-32210	GUARD	1						
50	T1007-73200	CORD COMP.	1						
51	1852-72121	GROMMET	1						
52	8488K40010	CLAMP	1						

Fig.3 ENGINE

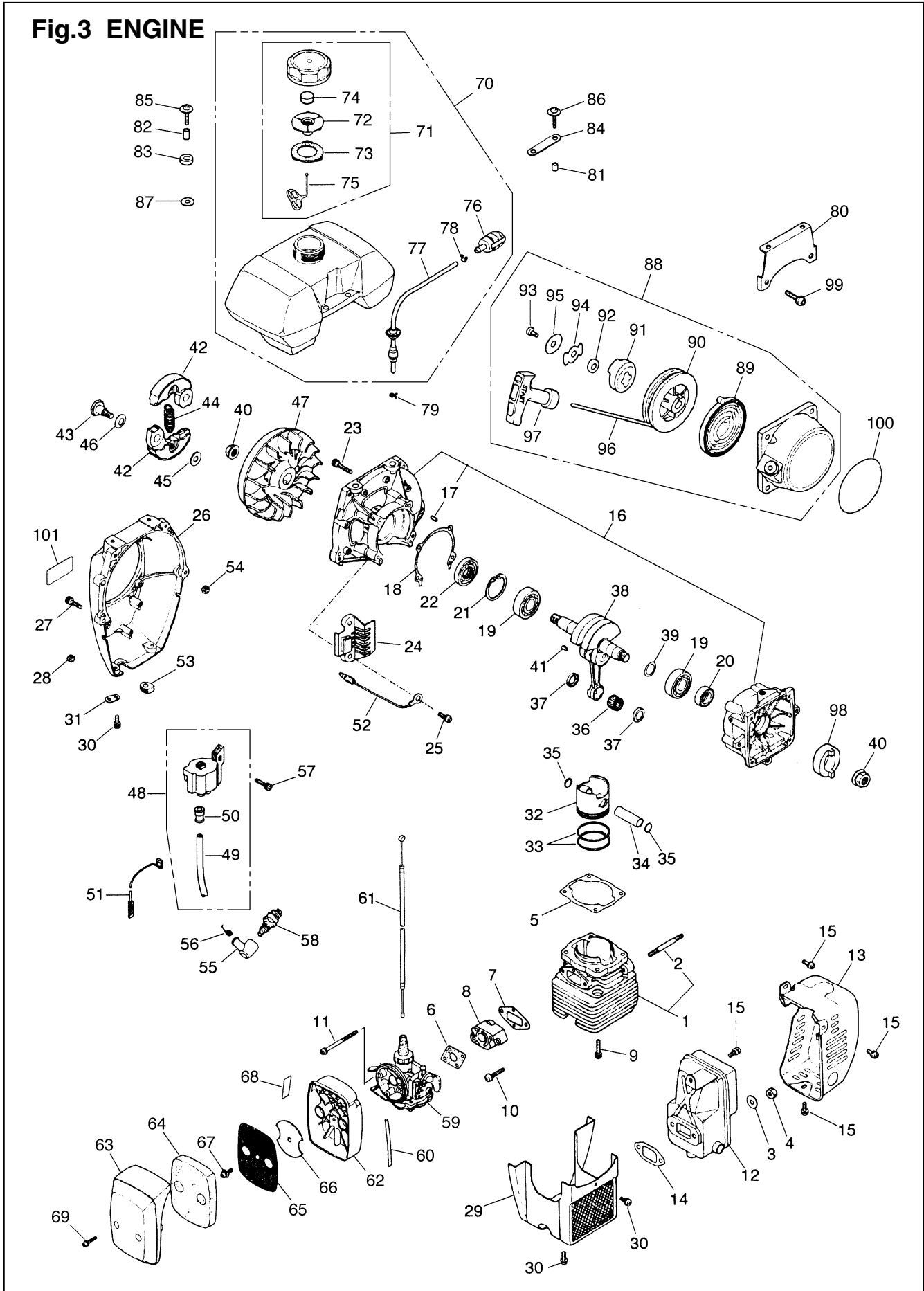
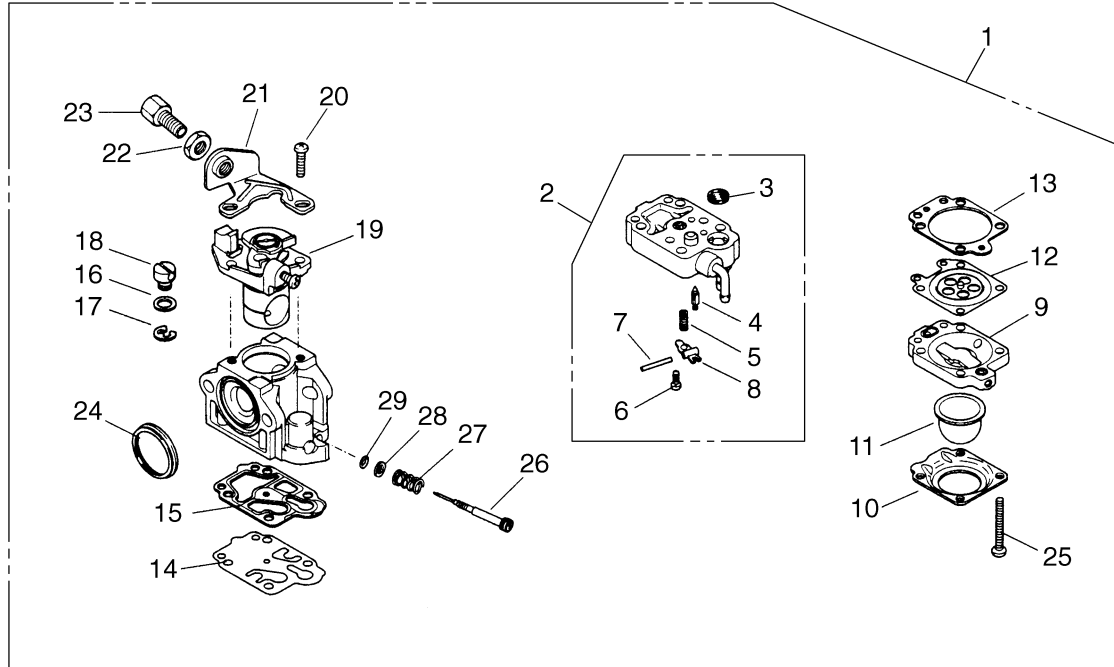

Fig.3 ENGINE

Key#	PART NUMBER	DESCRIPTION	Q'TY /UNIT	NOTE	Key#	PART NUMBER	DESCRIPTION	Q'TY /UNIT	NOTE
1	1580-12101	CYLINDER COMP.	1		53	5500-72130	GROMMET	1	
2	1580-12150	• STUD	2		54	1100-72120	GROMMET	1	
3	1140-51230	WASHER	2		55	5500-72110	PLUG CAP	1	
4	1580-15230	NUT	2		56	1900-72120	SPRING	1	
5	1400-13122	GASKET, cylinder	1		57	0263-90520	SCREW	2	M5x20
6	1420-13131	GASKET, carburetor	1		58	3699-90280	SPARKPLUG CHAMPION	1	CJ8Y
7	1400-13151	GASKET, insulator	1		59	1580-81000	CARBURETOR ASS'Y	1	
8	1580-13161	INSULATOR	1		60	1420-86180	PIPE	1	
9	1850-12130	BOLT	4	M5x22	61	T1137-84310	THROTTLE CABLE	1	
10	0260-30525	SCREW	2	M5x25	62	1400-82113	BODY	1	
11	0263-90550	SCREW	2	M5x50	63	1400-82121	COVER	1	
12	1400-15111	MUFFLER	1		64	1418-82130	ELEMENT	1	
13	1400-15410	MUFFLER COVER	1		65	1400-82141	SCREEN	1	
14	1580-13141	GASKET, muffler	1		66	1580-82150	PLATE	1	
15	0263-90512	SCREW	4	M5x12	67	1580-82160	SCREW	1	M4x25
16	1400-21100	CRANKCASE.COMP.	1		68	1133-82060	LABEL	1	
17	2629-21130	• PIN	3		69	4550-82150	SCREW	2	
18	1400-21141	GASKET, case	1		70	1439-85001	TANK ASS'Y	1	
19	06030-06202	BEARING	2		71	T1015-85202	• CAP ASS'Y	1	
20	1520-21220	OIL SEAL	1		72	4500-85300	•• HOLDER ASS'Y	1	
21	04065-03515	SNAP RING	1	ø35	73	4500-85220	•• PACKING	1	
22	1400-21220	OILSEAL	1		74	5601-85260	•• FILTER	1	
23	01252-30530	BOLT	4	M5x30	75	4820-85260	•• STOPPER	1	
24	2155-21311	GUARD	1		76	1435-85401	• FILTER ASS'Y	1	
25	0263-90514	SCREW	2	M5x14	77	1421-85400	• PUMP COMP.	1	
26	1400-31113	FAN COVER	1		78	1260-85460	• CLIP	1	
27	3310-12281	BOLT	4	M5x20	79	1063-86130	CLIP	1	
28	1100-72120	GROMMET	1		80	1400-86214	SUPPORT	1	
29	1462-32111	CYLINDER COVER	1		81	1400-86250	COLLAR	2	
30	0263-90512	SCREW	3	M5x12	82	1400-86260	COLLAR	2	
31	1600-86130	CLAMP	1		83	1400-86271	CUSHION	2	
32	3360-41110	PISTON	1		84	1580-86290	PLATE	1	
33	3360-41211	PISTON RING	2		85	1460-85850	SCREW	2	
34	3360-41310	PISTON PIN	1		86	0263-90520	SCREW	2	M5x20
35	3350-41320	SNAP RING	2		87	1400-86280	WASHER	2	
36	1400-41410	BEARING	1		88	T4030-75100	RECOIL ASS'Y	1	
37	2670-41510	WASHER	2		89	1180-75221	• SPRING	1	
38	1400-42002	CRANKSHAFT COMP.	1		90	T4030-75120	• REEL	1	
39	1300-42410	SIM	0~1		91	T4030-75140	• DOG	1	
40	1400-43230	NUT	2		92	1861-75150	• WASHER	1	
41	1000-43240	KEY	1		93	1483-75270	• SCREW	1	
42	4500-51111	SHOE	2		94	1487-75160	• RETAINER	1	
43	1200-51211	SCREW	2		95	1487-75170	• WASHER	1	
44	4500-51220	SPRING	1		96	1400-75160	• ROPE	1	
45	1200-51230	WASHER	2		97	1400-75170	• KNOB	1	
46	1200-51241	WASHER	2		98	1487-75211	PULLEY	1	
47	2073-71110	ROTOR	1		99	0263-90520	SCREW	4	M5x20
48	2155-71200	COIL ASS'Y	1		100	1580-75412	LABEL, recoil	1	
49	2155-71220	• CORD	1		101	1660-31121	LABEL	1	
50	2616-71320	• CAP	1						
51	2155-71240	CORD	1						
52	2116-71250	CORD, earth	1						

AG4300

Fig.4 CARBURETOR



Key#	PART NUMBER	DESCRIPTION	Q'TY /UNIT	NOTE	Key#	PART NUMBER	DESCRIPTION	Q'TY /UNIT	NOTE
1	4500-81001	CARBURETOR ASS'Y	1	WYK-93	20	1752-81110	• SCREW	2	
2	1850-81450	• BODY ASS'Y	1		21	5500-81120	• BRACKET	1	
3	3306-81380	•• SCREEN	1		22	1751-81180	• NUT, adjuster	1	
4	3356-81310	•• VALVE	1		23	5730-81170	• SCREW, adjuster	1	
5	1850-81270	•• SPRING	1		24	1881-81130	• RING, packing	1	
6	1850-81220	•• SCREW	1		25	1850-81530	• SCREW	4	
7	3310-81250	•• PIN	1		26	1484-81610	• NEEDLE, high speed	1	
8	3310-81230	•• LEVER	1		27	1491-81160	• SPRING	1	
9	1850-81490	• BODY, purge	1		28	1881-81190	• WASHER	1	
10	1850-81520	• COVER, pump	1		29	1881-81240	• O-RING	1	
11	1751-81510	• PUMP, priming	1						
12	3310-81260	• DIAPHRAGM	1						
13	1850-81470	• GASKET, diaphragm	1						
14	1065-81420	• DIAPHRAGM, pump	1						
15	1065-81410	• GASKET, pump	1						
16	5500-81160	• WASHER	1						
17	1751-81130	• E-RING	1						
18	1881-81140	• SWIVEL	1						
19	4500-81150	• VALVE ASS'Y	1						

Fig.5 CARBURETOR

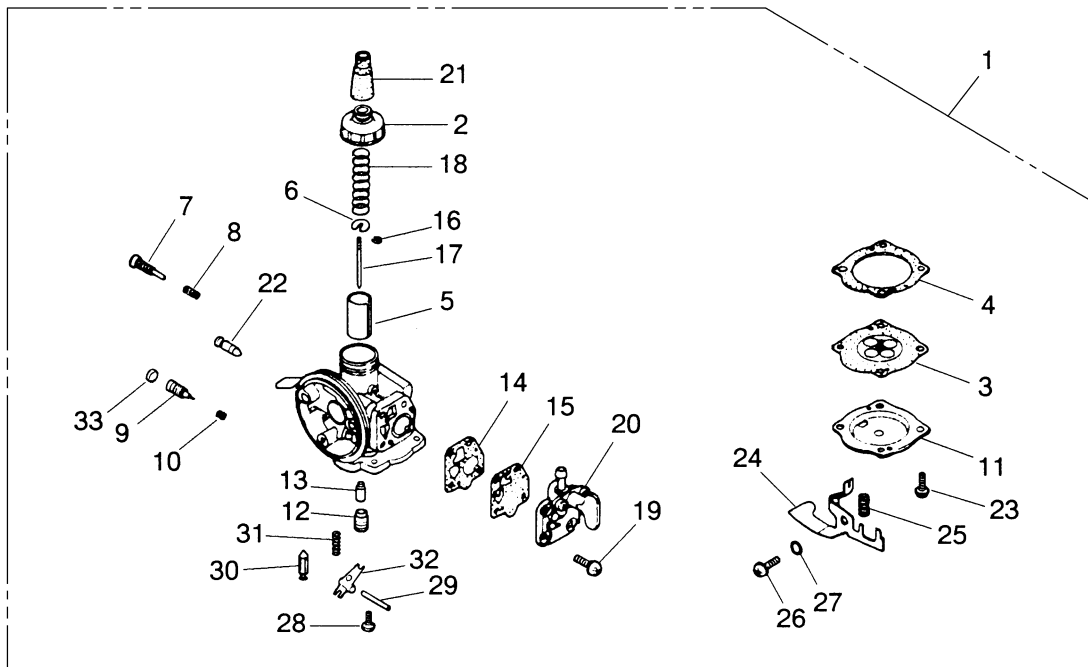

Key#	PART NUMBER	DESCRIPTION	Q'TY /UNIT	NOTE	Key#	PART NUMBER	DESCRIPTION	Q'TY /UNIT	NOTE
1	1580-81000	CARBURETOR ASS'Y	1	DPW13G	20	1422-81800	• COVER ASS'Y	1	
2	1650-81122	• CAP	1		21	3422-81130	• CAP	1	
3	1580-81480	• DIAPHRAGM ASS'Y	1		22	1130-81170	• VALVE ASS'Y	1	
4	1101-81950	• PACKING	1		23	0260-10308	• SCREW	4	M3x8
5	1420-81150	• THROTTLE VALVE	1		24	1420-81510	• LEVER	1	
6	1335-81070	• RECEIVE	1		25	1420-81520	• SPRING	1	
7	1038-81001-29	• SCREW	1		26	0260-00408	• SCREW	1	M4x8
8	1650-81260	• SPRING	1		27	1420-81530	• COLLAR	1	
9	1420-81271	• SCREW, main jet	1		28	0260-00306	• SCREW	1	M3x6
10	1420-81370	• SPRING	1		29	1100-81461	• PIN	1	
11	1420-81490	• COVER	1		30	1100-81440	• VALVE	1	
12	1420-81420	• HOLDER	1		31	1420-81430	• SPRING	1	
13	1420-81410	• JET	1		32	1420-81450	• LEVER	1	
14	1420-81730	• PACKING	1		33	1420-81620	• PLATE	1	
15	1420-81720	• PUMP	1						
16	1101-81190	• CLIP	1						
17	1580-81180	• NEEDLE	1						
18	1335-81060	• SPRING	1						
19	0260-10310	• SCREW	4	M3x10					

Fig.6 DRILL and ACCESSORY

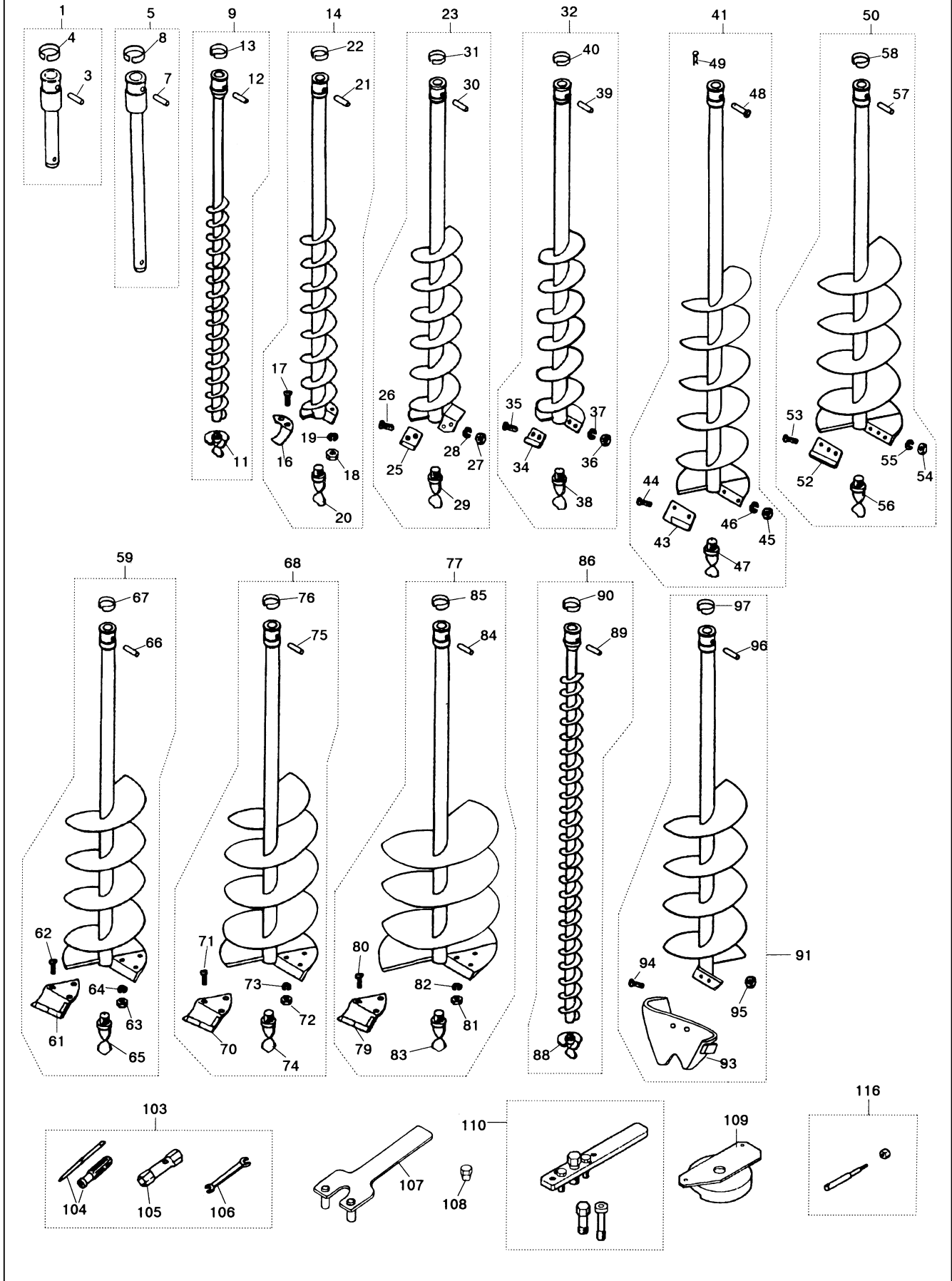

Fig.6 DRILL and ACCESSORY

Key#	PART NUMBER	DESCRIPTION	Q'TY /UNIT	NOTE	Key#	PART NUMBER	DESCRIPTION	Q'TY /UNIT	NOTE
1	Z320453100000	JOINT-L100 ASSY	1		61	3202-52420	• TIP S200	1	
3	3200-51130	• PIN	1		62	01225-40620	• SCREW	3	
4	3200-51140	• CLIP	1		63	0280-10605	• NUT	3	
5	Z320453200000	JOINT-L300 ASSY	1		64	0290-20615	• WASHER	3	
7	3200-51130	• PIN	1		65	3206-52330	• BIT	1	
8	3200-51140	• CLIP	1		66	3200-51130	• PIN	1	
9	Z320251102000	DRILL S40 ASSY	1		67	3200-51140	• CLIP	1	
11	3202-51121	• BIT	1		68	Z320652500000	DRILL S250 ASSY	1	
12	3200-51130	• PIN	1		70	3202-52520	• TIP S250	1	
13	3200-51140	• CLIP	1		71	01225-40620	• SCREW	3	
14	Z320652100000	DRILL S60 ASSY	1		72	0280-10605	• NUT	3	
16	3202-52121	• TIP S60	1		73	0290-20615	• WASHER	3	
17	01225-40620	• SCREW	2		74	3206-52330	• BIT	1	
18	0280-10605	• NUT	2		75	3200-51130	• PIN	1	
19	0290-20615	• WASHER	2		76	3200-51140	• CLIP	1	
20	3206-52330	• BIT	1		77	Z320653300000	DRILL S300 ASSY	1	
21	3200-51130	• PIN	1		79	3202-52620	• TIP S300	1	
22	3200-51140	• CLIP	1		80	01225-40620	• SCREW	3	
23	Z320652600000	DRILL S80 ASSY	1		81	0280-10605	• NUT	3	
25	3206-52620	• TIP S80	1		82	0290-20615	• WASHER	3	
26	01225-40620	• SCREW	2		83	3206-52330	• BIT	1	
27	0280-10605	• NUT	2		84	3200-51130	• PIN	1	
28	0290-20615	• WASHER	2		85	3200-51140	• CLIP	1	
29	3206-52330	• BIT	1		86	Z320651100000	DRILL S40L ASSY	1	
30	3200-51130	• PIN	1		88	3202-51121	• BIT	1	
31	3200-51140	• CLIP	1		89	3200-51130	• PIN	1	
32	Z320652200000	DRILL S90 ASSY	1		90	3200-51140	• CLIP	1	
34	3206-52220	• TIP S90	1		91	Z320661100000	DRILL I-150 ASSY	1	
35	01225-40620	• SCREW	2		93	3206-61120	• BLADE	1	
36	0280-10605	• NUT	2		94	0225-50620	• BOLT	2	
37	0290-20615	• WASHER	2		95	0280-10605	• NUT	2	
38	3206-52330	• BIT	1		96	3200-51130	• PIN	1	
39	3200-51130	• PIN	1		97	3200-51140	• CLIP	1	
40	3200-51140	• CLIP	1		103	3206-91001	TOOL SET	1	
41	Z320652900000	DRILL S120 ASSY	1		104	1030-91340	• DRIVER	1	
43	3206-52920	• TIP S120	1		105	3239-91310	• SOCKET	1	
44	01225-40620	• SCREW	2		106	3540-91120	• SOCKET	1	
45	0280-10605	• NUT	2		107	3206-91610	SPANNER	1	OP
46	0290-20615	• WASHER	2		108	3206-91620	ROD	1	OP
47	3206-52330	• BIT	1		109	1400-96210	SET BLOCK	1	OP, AG531
48	3206-52930	• PIN	1		110	2890-96100	PULLER ASSY	1	OP
49	04052-00833	• SNAPPING	1		116	1400-96300	ROD ASSY	1	OP
50	Z320652300000	DRILL S150 ASSY	1						
52	3206-52320	• TIP S150	1						
53	01225-40620	• SCREW	3						
54	0280-10605	• NUT	3						
55	0290-20615	• WASHER	3						
56	3206-52330	• BIT	1						
57	3200-51130	• PIN	1						
58	3200-51140	• CLIP	1						
59	Z320652400000	DRILL S200 ASSY	1						