

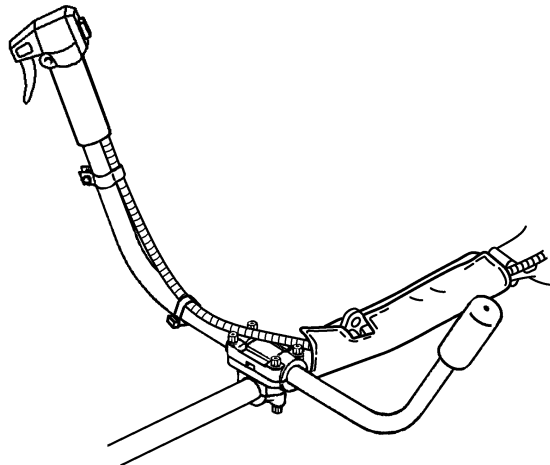

INSTALLATION MANUAL

BRUSHCUTTERS

W-HANDLE KIT



Manual For W-HANDLE Kit

1

Mount the handle to the shaft tube and clamp it at your best operating position.

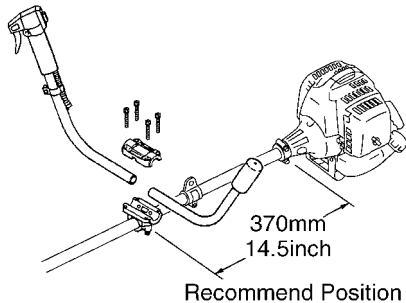

3

CONNECTING SWITCH WIRES

- Connect the switch wires between the engine and the main unit. Pair the wires of the same color

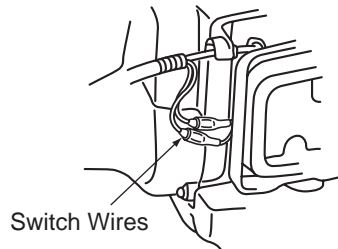

2

CONNECTING THROTTLE WIRE TO THE CARBURETOR

1. Remove the air cleaner cover.

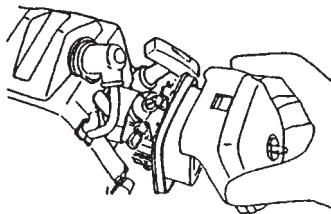

2. Connect the end of the throttle wire to the joint on the top of the carburetor.

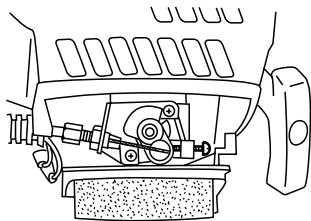

ADJUSTING THROTTLE CABLE

- The normal play is 1 or 2mm when measured at the carburetor side end. Readjust with the cable adjuster as required.

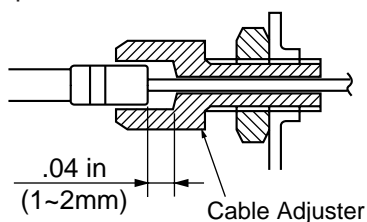

4

PUTTING ON WAIST PAD

- Wrap the waist pad around the shaft tube and the throttle wire.

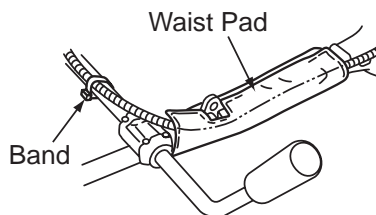

Parts List

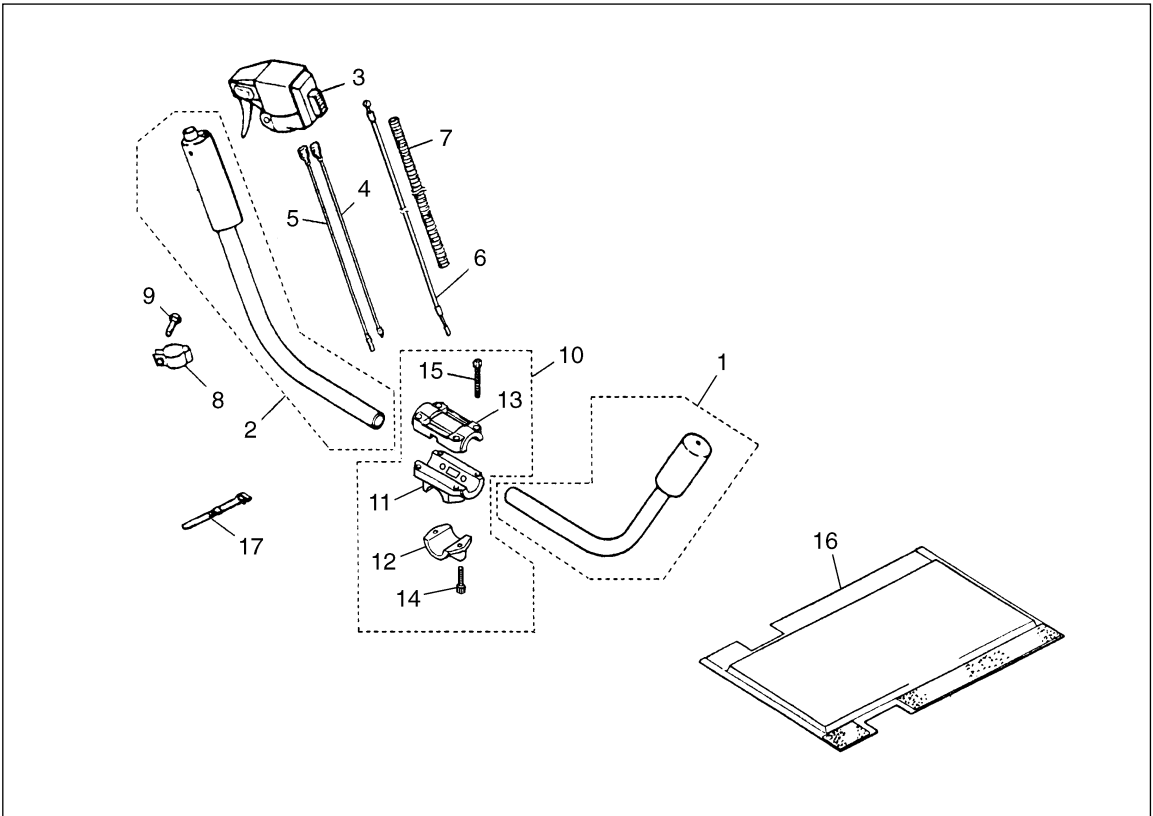

Key#	Description	Part Number	Q'ty	Key#	Description	Part Number	Q'ty
1	HANDLE-L-COMP	T3040-14200	1				
2	HANDLE-R-COMP	T3002-95400	1				
3	LEVER-ASSY	6234-14601	1				
4	CORD(A) BLACK	T3002-95710	1				
5	CORD(B) RED	T3002-95720	1				
6	CABLE-COMP	T3040-83100	1				
7	TUBE	5512-73220	1				
8	CLAMP	3260-14251	1				
9	SCREW	0260-00516	1				
10	BRACKET-ASSY	3583-14101	1				
11	• BRACKET	3583-14111	1				
12	• CAP-L	3583-14121	1				
13	• CAP-U	3257-14192	1				
14	• BOLT	01252-30522	2				
15	• BOLT	01252-30525	4				
16	PROTECTOR	4050-17110	5				
17	BAND	3540-93120	1				



KOMATSU ZENOAH AMERICA INC.
4344 Shackleford Road Suite 500
Norcross, Georgia 30093