

CONTENTS :

- Fig1 – ENGINE BLOCK • MUFFLER
- Fig2 – OUTER PARTS OF ENGINE
- Fig3 – RECOIL STARTER
- Fig4 – CARBURETOR
- Fig5 – DRIVE SHAFT
- Fig6 – HANDLE • OVER • BAND
- Fig7 – GEARCASE
- Fig8 – BLADE • OPTION

BRUSH CUTTER

BC3400FW

BC4300FW

NOTE :

1. Use KOMATSU ZENOAH genuine parts specified in the parts list for repair and/or replacement.
 2. KOMATSU ZENOAH does not warrant the machines, those which have been damaged by the use of any parts other than those specified by the company.
 3. When placing orders of parts for repair and/or replacement, check if the model name and serial number are suitable to those specified in the parts list, then use parts number described in the parts list.
 4. The contents described in the parts list may change due to improvement.
 5. The parts for the machine shall be supplied within ten (10) years after the machine is discontinued.
- [It is possible that some specific parts may be subject to change of their delivery term and list price within the limit of ten (10) years after the machine is discontinued. And it is also possible that some parts may be available even after the limit of ten (10) years.]

March 1999**APPLICABLE SERIAL NUMBER: 900101 and up**

Fig.1 ENGINE BLOCK-MUFFLER

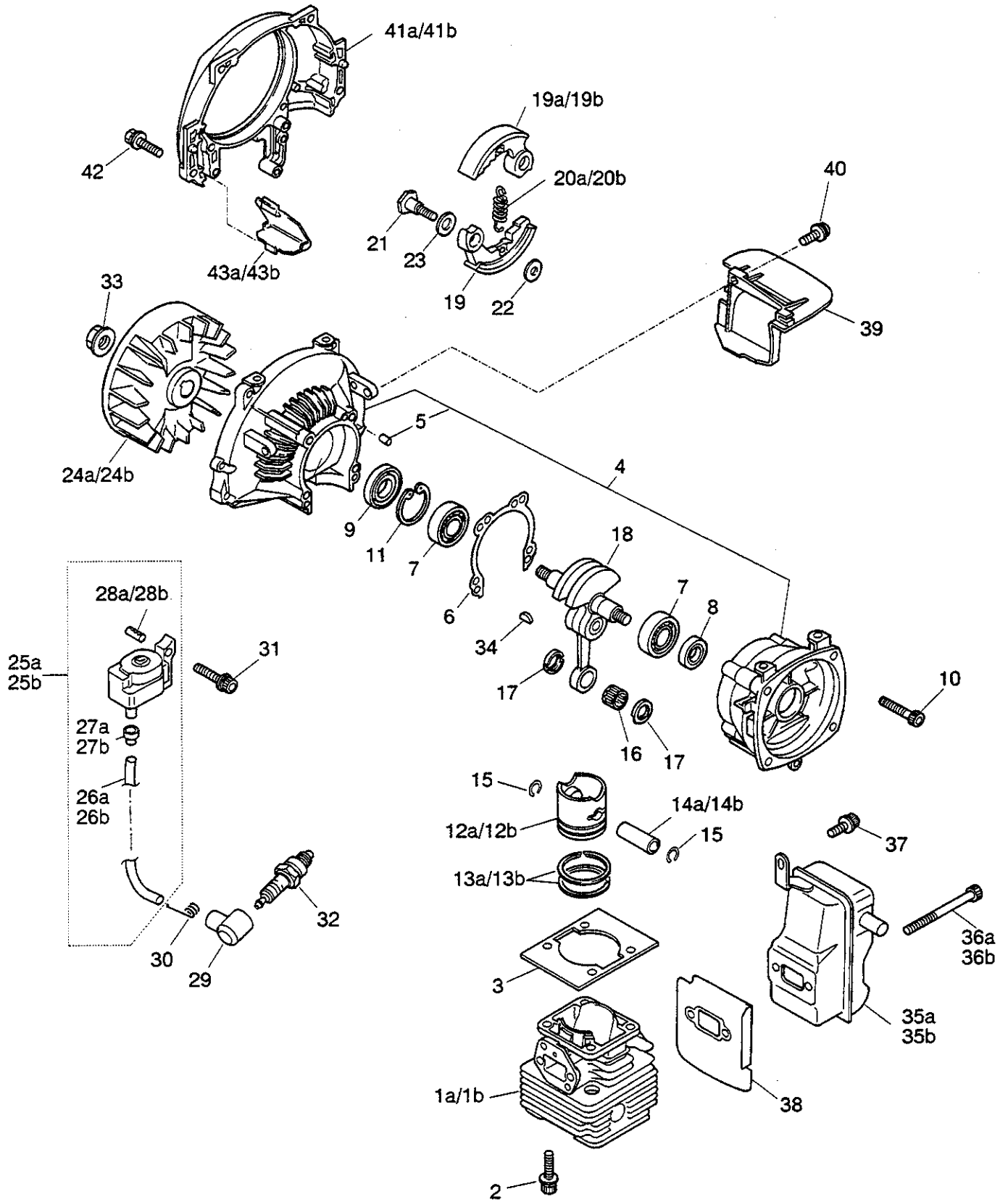

Fig. 1 ENGINE BLOCK·MUFFLER

key#	PART NUMBER	PART NAME	NOTE	Q'TY	
				BC3400FW	BC4300FW
1a	4700-12110	CYLINDER		1	
1b	4500-12110	CYLINDER			1
2	3310-12281	BOLT		4	4
3	4500-13120	GASKET , base		1	1
4	4500-21100	CRANKCASE COMP		1	1
5	2629-21130	·PIN		3	3
6	4500-21140	GASKET, case		1	1
7	06030-06201	BEARING		2	2
8	2169-21210	OIL SEAL		1	1
9	1650-21220	OIL SEAL		1	1
10	01252-30530	BOLT		4	4
11	04065-03212	RING		1	1
12a	4700-41110	PISTON		1	
12b	4500-41110	PISTON			1
13a	1650-41210	RING		2	
13b	1400-41220	RING			2
14a	1030-41310	PIN		1	
14b	2850-41310	PIN			1
15	1300-41320	RING		2	2
16	2850-41410	BEARING		1	1
17	2850-41510	WASHER		2	2
18	4500-42000	CRANKSHAFT COMP		1	1
19a	4700-51110	SHOE, clutch		2	
19b	4500-51110	SHOE, clutch			2
20a	1651-51220	SPRING		1	
20b	4500-51220	SPRING			1
21	1200-51211	SCREW		2	2
22	1200-51230	WASHER		2	2
23	1200-51241	WASHER		2	2
24a	4700-71110	ROTER		1	
24b	4500-71110	ROTER			1
25a	4770-71200	COIL ASS'Y		1	
25b	4570-71200	COIL ASS'Y			1
26a	4770-71220	·CORD		1	
26b	4570-71220	·CORD			1
27a	4700-71230	·CAP		1	
27b	2616-71320	·CAP			1
28a	4700-71240	·PIN		2	
28b	3356-21130	·PIN			2
29	1900-72111	CAP, plug		1	1
30	1900-72120	SPRING		1	1
31	4500-72150	BOLT		2	2
32	1881-73110	SPARKPLUG		1	1
33	1650-43230	NUT		1	1
34	1000-43240	KEY		1	1
35a	4770-15110	MUFFLER		1	1
35b	4570-15110	MUFFLER		1	1
36a	01252-30560	BOLT		2	
36b	01252-30565	BOLT			2
37	3310-31720	BOLT		1	1
38	4570-15211	GASKET		1	1
39	4570-15220	PLATE		1	1
40	0263-90514	SCREW		1	1
41a	4700-31110	COVER		1	1
41b	4500-31110	COVER		1	1
42	3310-12281	BOLT		4	4
43a	4700-31210	PLATE		1	
43b	4500-31210	PLATE			1

Fig.2 OUTER PARTS OF ENGINE

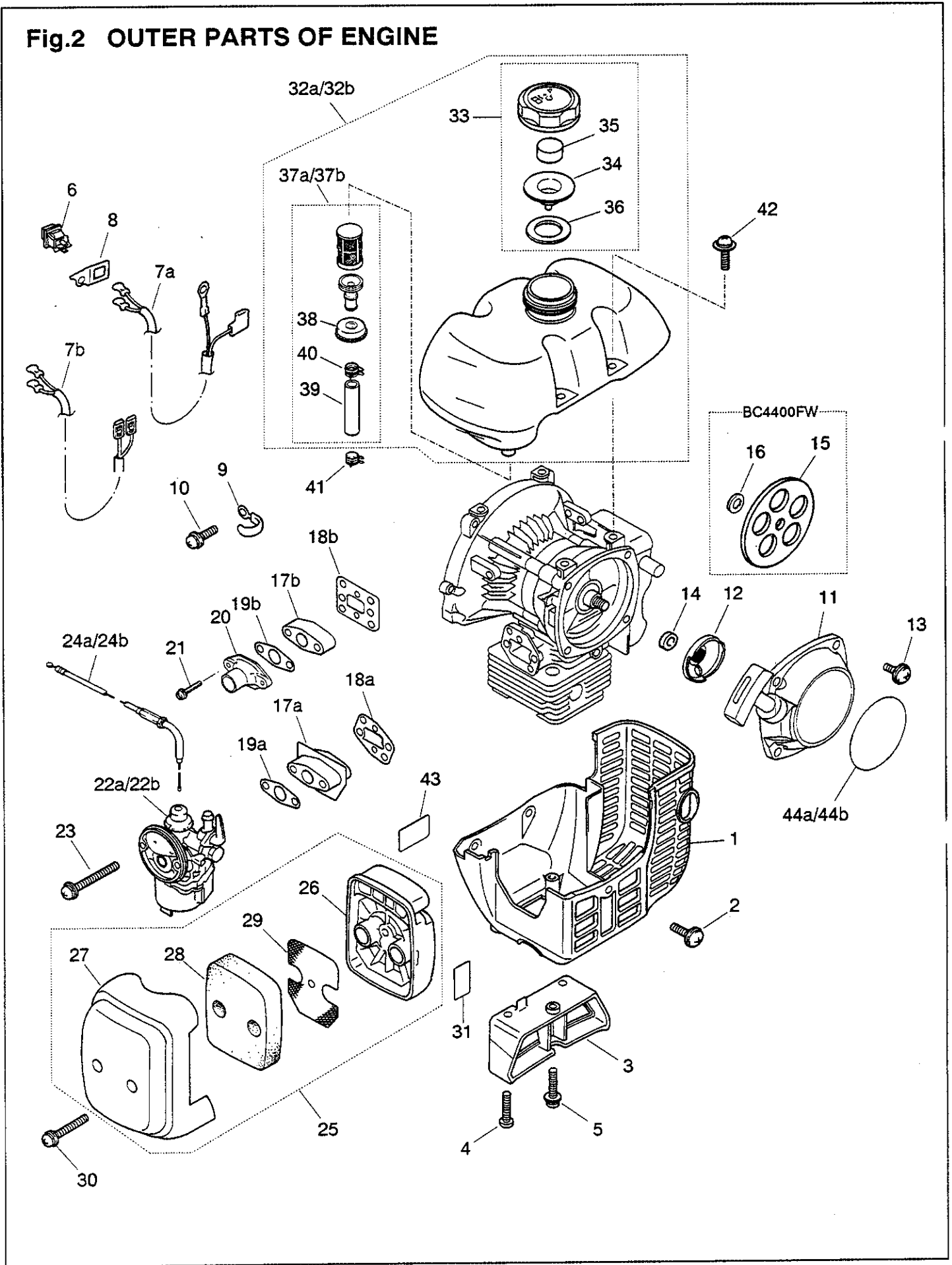

Fig. 2 OUTER PARTS OF ENGINE

key#	PART NUMBER	PART NAME	NOTE	Q'TY	
				BC3400FW	BC4300FW
1	4570-32110	COVER, cylinder		1	1
2	4500-32120	SCREW		3	3
3	4570-31900	STAND-C		1	1
4	3356-32210	SCREW		2	2
5	0263-90520	SCREW	M5 × 20	1	1
6	4500-73210	SWITCH		1	1
7a	4770-71240	CORD COMP		1	
7b	4570-71240	CORD COMP			1
8	4570-72260	BRACKET		1	1
9	1140-72231	CLAMP		1	1
10	0263-90514	SCREW	M5 × 14	1	1
11	4500-75100	RECOIL ASS'Y		1	1
12	4500-75210	PULLEY		1	1
13	4500-75511	SCREW	M5 × L14	4	4
14	4700-75310	COLLER		1	
15	4500-75310	PLATE			1
16	01643-20823	WASHER			1
17a	4750-13160	INSULATOR		1	
17b	1695-13161	INSULATOR			1
18a	4700-13150	GASKET		1	
18b	4500-13150	GASKET			1
19a	4750-13130	GASKET, carb		1	
19b	1695-13130	GASKET, carb			1
20	1695-13171	PIPE			1
21	0263-90530	SCREW	M5 × L30		2
22a	4770-81002	CARBURETOR ASS'Y		1	
22b	4570-81000	CARBURETOR ASS'Y			1
23	0263-90560	SCREW	M5 × 60	2	
24a	1600-97150	CABLE COMP		1	
24b	1600-83101	CABLE COMP			1
25	4570-82000	CLEANER ASS'Y		1	1
26	1400-82113	•BODY		1	1
27	4570-82120	•COVER		1	1
28	1418-82130	•ELEMENT		1	1
29	1400-82141	•SCREEN		1	1
30	4550-82150	SCREW		2	2
31	1133-82060	LABEL		1	1
32a	4770-85000	TANK ASS'Y		1	
32b	4570-85000	TANK ASS'Y			1
33	4570-85200	•CAP ASS'Y		1	1
34	4570-85230	••CAP		1	1
35	1030-85140	••ELEMENT		1	1
36	4500-85220	••PACKING		1	1
37a	1620-85404	•JOINT ASS'Y		1	
37b	1400-85104	•JOINT ASS'Y			1
38	1400-85141	••GROMMET		1	1
39	1000-08045	••TUBE		1	1
40	1410-86130	••CLIP		1	1
41	3073-86130	CRIP		1	1
42	1600-86120	SCREW	M5 × 22	4	4
43	1660-31121	LABEL		1	1
44a	T1013-75410	LABEL, recoil	G34L	1	
44b	T1012-75410	LABEL, recoil	G43L		1

Fig.3 RECOIL STARTER

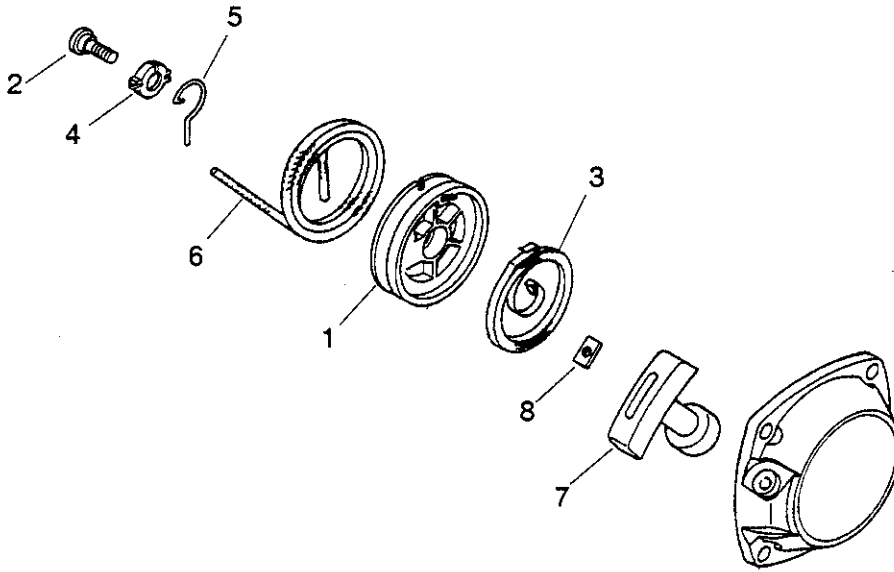

Fig.4 CARBURETOR FOR BC3400FW

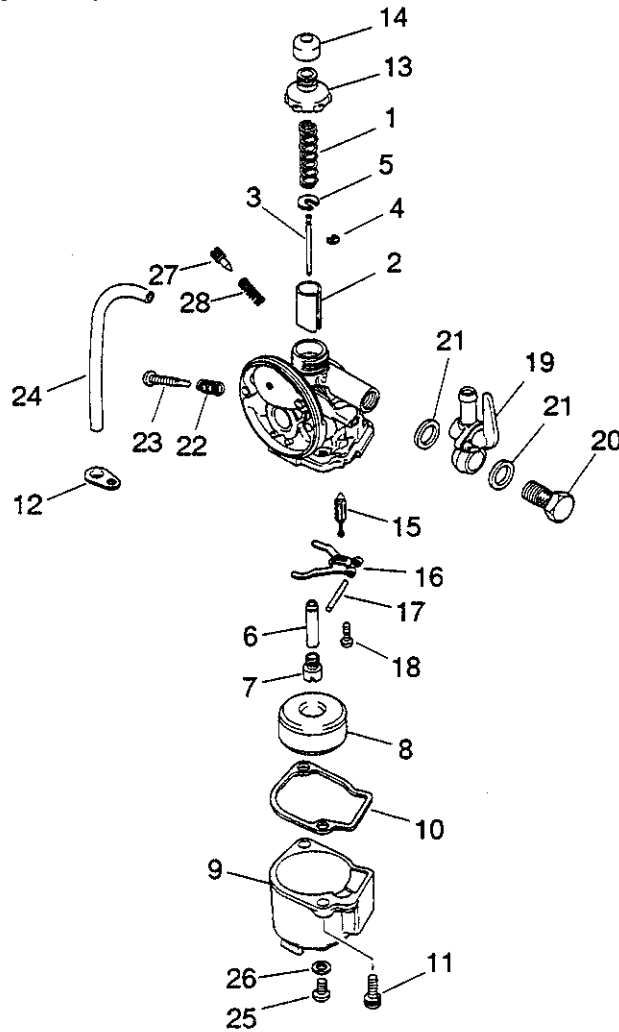

Fig. 3 RECOIL STARTER

key#	PART NUMBER	PART NAME	NOTE	Q'TY	
				BC3400FW	BC4300FW
	4500-75100	RECOIL ASS'Y		1	1
1	4500-75120	•REEL		1	1
2	4500-75150	•SCREW		1	1
3	1850-75130	•SPRING		1	1
4	4500-75180	•COLLOR		1	1
5	4500-75190	•ARM		1	1
6	4500-75160	•ROPE	φ 3.5×880	1	1
7	1140-75320	•KNOB		1	1
8	5500-75170	•PLATE		1	1

Fig. 4 CARBURETOR FOR BC3400FW

key#	PART NUMBER	PART NAME	NOTE	Q'TY	
				BC3400FW	
	4770-81002	CARBURETOR ASS'Y		1	
1	1030-81000-14	•SPRING		1	
2	4770-81160	•VALVE	CA:0.75	1	
3	4770-81210	•NEEDLE, jet		1	
4	1030-81000-16	•CLIP		1	
5	1030-81000-17	•RECEIVE		1	
6	4770-81230	•JET	φ 2.090	1	
7	1879-81240	•JET	#55	1	
8	1695-81180	•FLOAT		1	
9	1614-81310	•CHAMBER		1	
10	1695-81320	•PACKING		1	
11	0263-10416	•SCREW		2	
12	1220-81420	•STAY		1	
13	1141-81110	•CAP		1	
14	1141-81120	•CAP		1	
15	1695-81360	•VALVE		1	
16	1695-81340	•HINGE		1	
17	1181-81210	•PIN		1	
18	0263-00306	•SCREW		1	
19	1179-81501	•COCK ASS'Y		1	
20	2166-81500	•BOLT		1	
21	1179-81221	•PACKING		2	
22	1650-81260	•SPRING		1	
23	2751-81250	•SCREW		1	
24	1220-81410	•VALVE		1	
25	1400-81650	•SCREW		1	
26	1400-81660	•PACKING		1	
27	5580-81910	•SCREW		1	
28	5580-81920	•SPRING		1	

Fig.4 CARBURETOR FOR BC4300FW

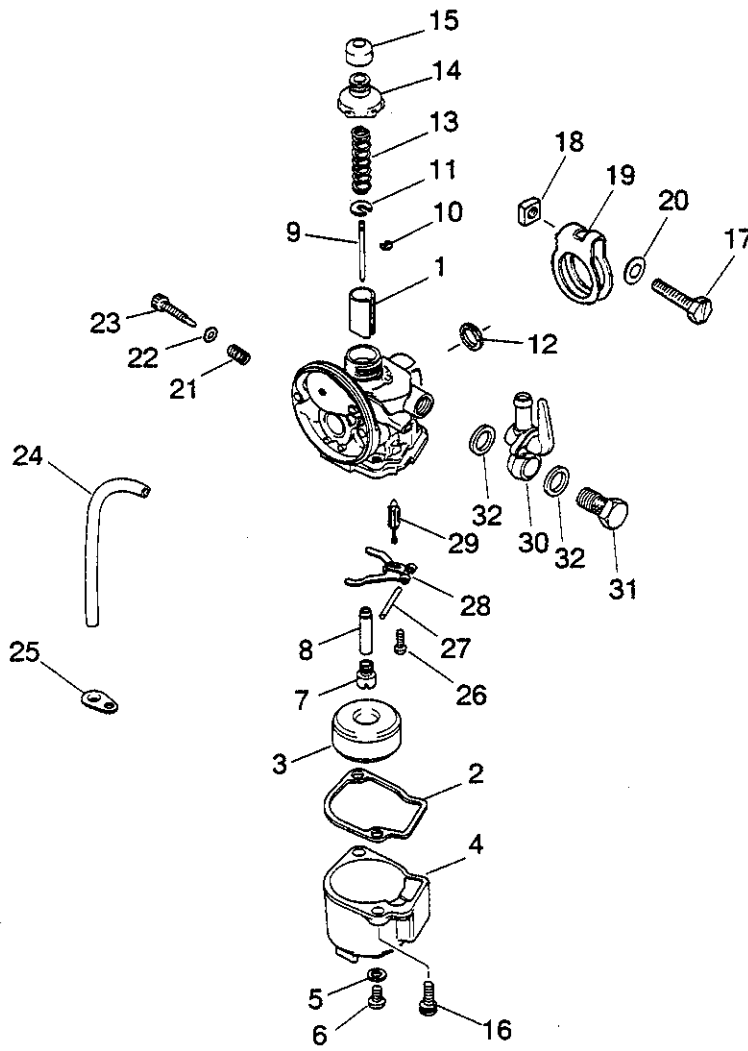

Fig.4 CARBURETOR FOR BC4300FW

key#	PART NUMBER	PART NAME	NOTE	Q'TY BC4300FW
	4570-81000	CARBURETOR ASS'Y		1
1	4570-81150	•VALVE		1
2	1695-81320	•PACKING		1
3	1695-81180	•FLOAT		1
4	1614-81310	•CHAMBER		1
5	1400-81660	•PACKING		1
6	1400-81650	•SCREW		1
7	1695-81240	•JET		1
8	1861-81230	•JET		1
9	1418-81210	•NEEDLE		1
10	1030-81000-16	•CLIP		1
11	1030-81000-17	•RECEIVE		1
12	1038-81002-34	•PACKING		1
13	1030-81000-14	•SPRING		1
14	1141-81110	•CAP		1
15	1141-81120	•CAP		1
16	0263-10416	•SCREW		2
17	1695-81290	•SCREW		1
18	1695-81270	•NUT		1
19	1695-81280	•BAND		1
20	1695-81580	•WASHER		1
21	1650-81260	•SPRING		1
22	1695-81540	•O-RING		1
23	1695-81250	•SCREW		1
24	1220-81410	•PIPE		1
25	1220-81420	•STAY		1
26	0263-00306	•SCREW		1
27	1181-81210	•PIN		1
28	1695-81340	•HINGE		1
29	1695-81360	•VALVE		1
30	1179-81501	•COCK ASS'Y		1
31	1179-81211	•BOLT		1
32	1179-81221	•PACKING		2

Fig.5 DRIVE SHAFT

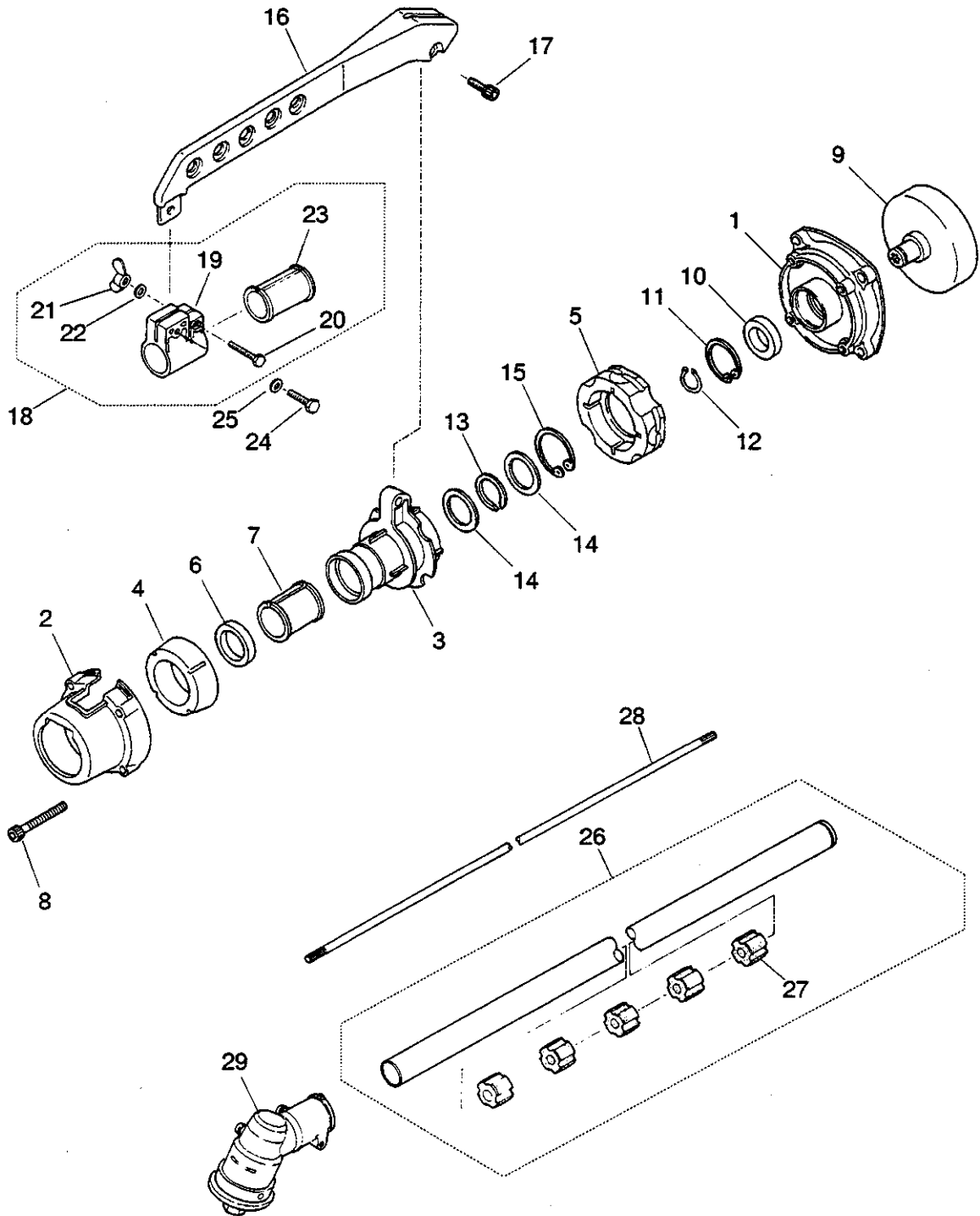

Fig. 5 DRIVE SHAFT

key#	PART NUMBER	PART NAME	NOTE	Q'TY	
				BC3400FW	BC4300FW
1	4050-11110	HOUSING		1	1
2	4050-11150	CAP		1	1
3	4000-11210	JOINT		1	1
4	4050-11250	ABSOBER F		1	1
5	4050-11260	ABSOBER R		1	1
6	3541-11120	SEAL		1	1
7	3541-11450	SPACER		1	1
8	01252-30530	BOLT	M5 × 30	4	4
9	4050-11310	DRUM		1	1
10	06004-06202	BEARING		1	1
11	04065-03515	RING		1	1
12	04064-01510	RING		1	1
13	3263-11410	RING		1	1
14	4000-11140	PLATE		2	2
15	04065-03715	RING		1	1
16	4000-11420	HANGER		1	1
17	1491-21511	BOLT	M6 × 30	1	1
18	3541-11441	BRACKET		1	1
19	3541-11432	•BRACKET		1	1
20	0224-00635	•BOLT	M6 × 35	1	1
21	3540-11460	•NUT		1	1
22	01642-20608	•WASHER		1	1
23	3541-11450	•SPACER		1	1
24	0224-00625	BOLT	M6 × 25	1	1
25	01642-20608	WASHER		1	1
26	4000-12100	PIPE COMP		1	1
27	3247-11321	•BUSH		5	5
28	3540-12211	SHAFT		1	1
29	4000-13000	GEARCASE ASS'Y		1	1

Fig.6 HANDLE·COVER·BAND

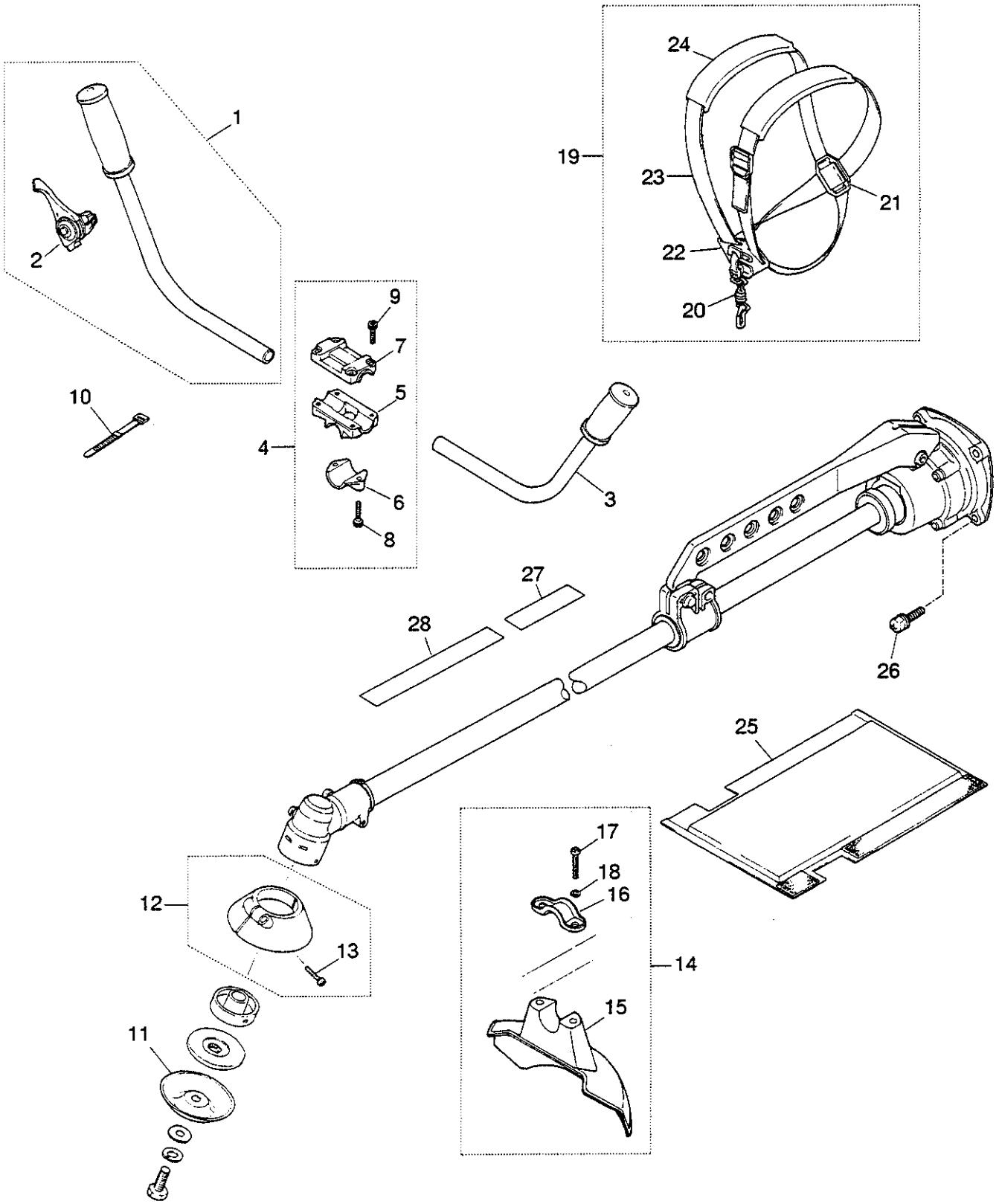

Fig. 6 HANDLE·COVER·BAND

key#	PART NUMBER	PART NAME	NOTE	Q'TY	
				BC3400FW	BC4300FW
1	4000-14300	RIGHT HANDLE COMP		1	1
2	3541-14400	·LEVER		1	1
3	4000-14200	LEFT HANDLE COMP		1	1
4	3532-14102	BRACKET COMP		1	1
5	3541-14172	·BRACKET		1	1
6	3541-14182	·CAP L		1	1
7	3257-14192	·CAP U		1	1
8	01252-30522	·BOLT	M5 × 22	2	2
9	01252-30525	·BOLT	M5 × 25	4	4
10	3540-93120	BAND		1	1
11	3520-13284	COVER		1	1
12	3541-13400	COVER ASS'Y		1	1
13	0263-30530	·SCREW	M5 × 30	1	1
14	3541-24001	GUARD ASS'Y		1	1
15	3541-24112	·GUARD		1	1
16	3541-24121	·CLUMP		1	1
17	3540-24130	·BOLT	M6 × 30	2	2
18	0290-20615	·WASHER		2	2
19	6565-17200	HARNESS ASS'Y		1	1
20	6565-17210	·HOOK		1	1
21	6565-17220	·PLATE		1	1
22	6565-95230	·HANGER COMP		1	1
23	6565-17200-01	·BAND		1	1
24	6565-17200-02	·PROTECTOR		2	2
25	4050-17110	PROTECTOR		2	2
26	6468-91150	BOLT	M6 × 20	4	4
27	4000-11270	PLATE		1	1
28	T3019-12510	PLATE, name		1	1

Fig.7 GEARCASE

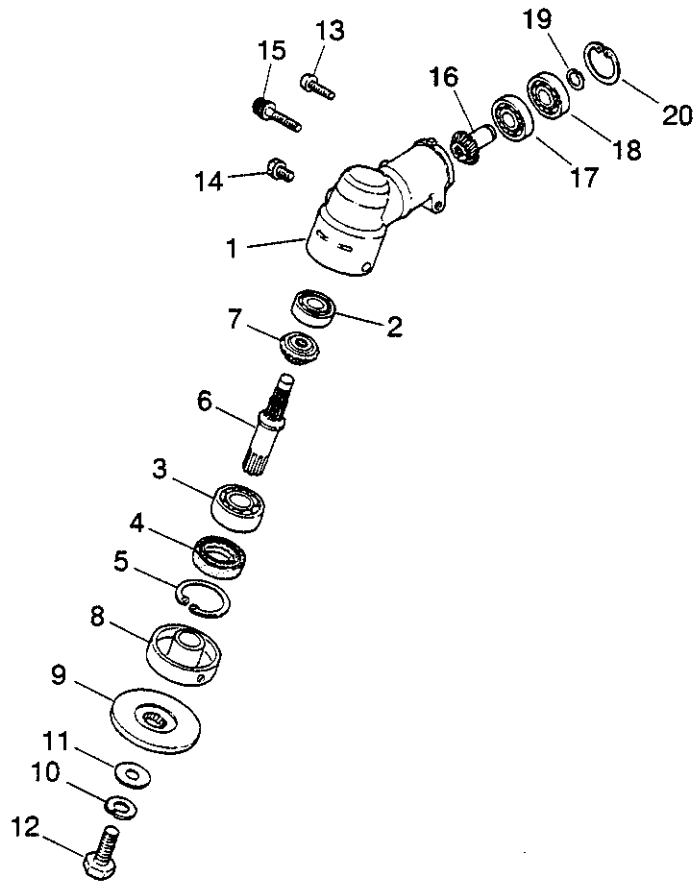
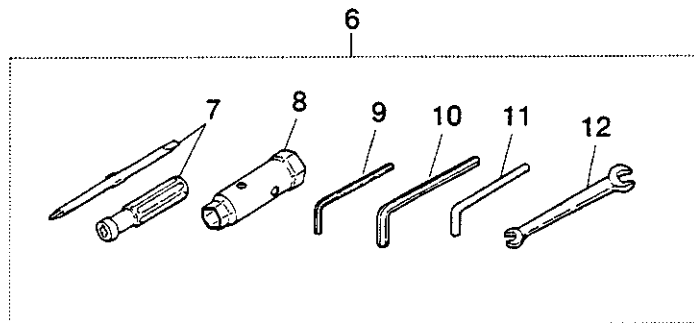
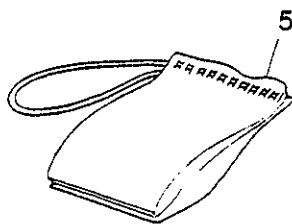
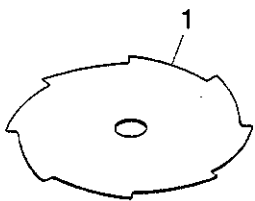

Fig.8 BLADE-OPTION



BC3400FW/BC4300FW

Fig. 7 GEARCASE

key#	PART NUMBER	PART NAME	NOTE	Q'TY	
				BC3400FW	BC4300FW
	4000-13000	GEARCASE ASS'Y		1	1
1	3541-13194	•GEARCASE		1	1
2	06000-06000	•BEARING		1	1
3	06000-06201	•BEARING		1	1
4	3180-13141	•SEAL		1	1
5	04065-03212	•RING		1	1
6	4050-13210	•SHAFT		1	1
7	3180-13220	•GEAR		1	1
8	3541-13241	•HOLDER A		1	1
9	3541-13251	•HOLDER B		1	1
10	3310-43210	•WASHER		1	1
11	01643-30823	•WASHER		1	1
12	3579-33260	•BOLT		1	1
13	01252-30510	•BOLT	M5×10	1	1
14	0224-40610	•BOLT	M6×10	1	1
15	3540-13260	•BOLT	M6×35	1	1
16	3541-13311	•PINION		1	1
17	06000-06000	•BEARING		1	1
18	06001-06000	•BEARING		1	1
19	3180-13330	•RING		1	1
20	04065-02612	•RING		1	1

Fig.8 BLADE • OPTION

key#	PART NUMBER	PART NAME	NOTE	Q'TY	
				BC3400FW	BC4300FW
1	6298-15343	SAW	8-teeth ϕ 255×t1.4×8T	1	1
5	3520-91110	BAG		1	1
6	3532-91000	TOOL SET		1	1
7	1030-91340	•DRIVER		1	1
8	3239-91310	•SOCKET	13×19	1	1
9	09007-00425	•WRENCH		1	1
10	09007-00528	•WRENCH		1	1
11	3540-91110	•BAR		1	1
12	3540-91120	•SPANNER	8×10	1	1