

# ***Operator's Manual***

***Rotary Tiller 42" & 66"***

---

# ***RT42***

# ***RT66***

Cub Cadet Yanmar LLC.  
P.O. Box 368023  
Cleveland, OH 44136

PRINTED IN U.S.A.

Version 1.0  
Code No.:769-03313

# **SAFETY**

Take note! This safety alert symbol found throughout this manual is used to call your attention to instructions involving your personal safety and the safety of others. Failure to follow these instructions can result in injury or death.



*This symbol means:*  
**ATTENTION!**  
**BECOME ALERT!**  
**YOUR SAFETY IS INVOLVED!**

## **Signal Words**

Note the use of the signal words **DANGER**, **WARNING** and **CAUTION** with the safety messages. The appropriate signal words for each has been selected using the following guidelines:



**DANGER:** Indicates an imminently hazardous situation that, if not avoided, will result in death or serious injury.



**WARNING:** Indicates a potentially hazardous situation that, if not avoided, could result in death or serious injury, and includes hazards that are exposed when guards are removed. It may also be used to alert against unsafe practices.



**CAUTION:** Indicates a potentially hazardous situation that, if not avoided, may result in minor or moderate injury

# INDEX

<b>1 - GENERAL INFORMATION</b>	4
1.01 - General	4
1.02 - Model and Serial Number ID	4
<b>2 - SAFETY PRECAUTIONS</b>	6
2.01 - Preparation	6
2.02 - Starting and Stopping	7
2.03 - Messages and Signs	7
<b>3 - OPERATION</b>	9
3.01 - Operational Safety	9
3.02 - Setup and Lubrication	11
3.03 - Side Shift	14
3.04 - Depth Control	15
3.05 - Rear Shield Adjustment	15
3.06 - Pre-Operational Check	16
3.07 - Attaching to the Tractor	16
3.08 - Start Up	18
3.09 - Test Run	19
3.10 - Working Depth	20
3.11 - Working Speed	20
3.12 - Finer Pulverization	20
3.13 - Headland Procedure	20
3.14 - Working Limitations	20
3.15 - Uneven Terrain	21
3.16 - Transport	21
<b>4 - MAINTENANCE</b>	22
4.01 - Maintenance Safety	22
4.02 - Service	23
4.03 - Blade Maintenance	23
4.04 - Driveline	24
4.05 - Safety Shear Pin Coupler	25
4.06 - Safety Slip Clutch	26
<b>5 - REPAIR PROCEDURES</b>	28
5.01 - Gearbox	28
5.02 - Chain Case	28
5.03 - Rotor	28
5.04 - Suggested Spare Parts	29
5.05 - Storage	29
<b>6 - TROUBLESHOOTING</b>	30
<b>7 - PRE-DELIVERY CHECKLIST</b>	31
<b>8 - PARTS MANUAL</b>	33

# 1 - GENERAL INFORMATION

Thank you and congratulations for having chosen our implement. Your new side shift tiller is a technologically advanced machine constructed of high quality, sturdy components and will fulfill your working expectations.

Read this manual carefully. It will instruct you on how to operate and service your machine safely and correctly. Failure to do so could result in personal injury and or equipment damage.

## 1.01 - General



**CAUTION:** All hardware is metric. Only metric tools should be used. Other tools that do not fit properly can slip and cause injury.



**CAUTION:** Right hand and left hand sides of the implement are determined by facing in the direction the implement will travel when going forward.

## 1.02 - Model and Serial Number ID

Attached to the frame is an ID plate showing the model and the serial number. Record your implement model and serial number in the space provided below. Your local dealer needs this information to give you prompt, efficient service when you order parts.

<b>Model #:</b>	<input type="text"/>
<b>Serial #:</b>	<input type="text"/>

**Carefully read the warranty section<sup>1</sup>** detailing coverage and limitations. **Warranty** is provided for customers who operate and maintain their equipment as described in this manual. Warranty registration is accomplished by the dealer by completing and forwarding the **Warranty Registration Form** to the Company, along with a copy of the invoice. It is in your best interest to insure that this has been done.

<sup>1</sup> See chapter 8 - Warranty.

Warranty does not cover the following:

1. Cleaning, transporting, mailing and service call charge.
2. Normal wear items such as blades, bearings, wheels, drivelines, shear pin, slip clutches etc.
3. Depreciation or damage caused by normal wear, accidents, improper maintenance, improper protection or improper use.
4. The use of non original spare parts and accessories.

Your local dealer has or can supply genuine parts. **Only these approved replacement parts should be used.**

This limited warranty covers defective material and workmanship. The cost of normal maintenance or repairs for accidents or improper use and related labor will be borne by the owner.

## 2 - SAFETY PRECAUTIONS

Safety is the primary concern in the design and manufacture of our products. Unfortunately our efforts to provide safe equipment can be wiped out by a single careless act of an operator.

In addition to the design and configuration of equipment, hazard control and accident prevention are dependent upon the awareness, concern, prudence and proper training of personnel involved in the operation, transport, maintenance and storage of equipment.

It is the operator's responsibility to read and understand all safety and operating instructions in the manual and to follow these.

Allow only properly trained personnel to operate the rotary tiller. Working with unfamiliar equipment can lead to careless injuries. Read this manual, and the manual for your tractor, before assembly or operating, to acquaint yourself with the machines. It is the tiller owner's responsibility, if this machine is used by any person other than yourself, is loaned or rented, to make certain that the operator, prior to operating, reads and understands the operator's manuals and is instructed in safe and proper use.

### 2.01 - Preparation



1. Before operating equipment read and understand the operator's manual and the safety signs (**see fig. 2**).
2. Thoroughly inspect the implement before initial operation to assure that all packaging materials, i.e. wires, bands, and tape have been removed.
3. Personal protection equipment including hard hat, safety glasses, safety shoes, and gloves are recommended during assembly, installation, operation, adjustment, maintaining and/or repairing the implement.
4. Operate the tiller only with a tractor equipped with an approved Roll-Over-Protective-System (ROPS). Always wear your seat belt. Serious injury or even death could result from falling off the tractor.
5. Clear area to be cut of stones, branches or other debris that might be thrown, causing injury or damage.
6. Operate only in daylight or good artificial light.
7. Ensure tiller is properly mounted, adjusted and in good operating condition.
8. Ensure that all safety shielding and safety signs are properly installed and in good condition.

## 2.02 - Starting and Stopping



1. Be sure that no one is near the machine prior to engaging or while the machine is working.
2. Be sure the tractor is in "Neutral" before starting engine.
3. Tiller operating power is supplied from tractor PTO. Refer to your tractor manual for PTO engagement and disengagement instructions. Always operate PTO at 540 rpm. Know how to stop the tractor and tiller quickly in case of an emergency.
4. When engaging PTO, the engine rpm should always be low. Once engaged and ready to start using, raise PTO speed to 540 rpm and maintain throughout operation.
5. Check the tractor master shield over the PTO stub shaft. Make sure it is in good condition and fastened securely to the tractor. Purchase a new shield if old shield is damaged or missing.
6. After striking an obstacle, disengage the PTO, shut the tractor down and thoroughly inspect for damage before restarting.
7. Never engage the PTO until the tiller is in the down position and resting on the ground. Never raise the tiller until the rotor has come to a complete stop.

## 2.03 - Messages and Signs



1. Read and adhere to all safety and operating decals on this machine (**see fig. 2**).
2. Before dismounting tractor: allow moving parts to stop, stop engine, set brake and remove the key of unattended equipment.
3. Keep away from rotating blades and driveline.
4. Keep guards and shields in place and in good condition.
5. Do not use with bystanders in area.
6. Allow no riders on tractor or tiller.
7. Allow moving parts to stop before repair.
8. Securely support tiller before working underneath.

Additional warning and operating decals are available at no extra charge. Please specify model and serial number when ordering.

Fig. 2 - Safety decals; replace immediately if damaged.





**⚠ DANGER**

To prevent Serious Injury or Death

- Avoid unsafe operation or maintenance.
- Do not operate or work on this machine without reading and understanding the operator's manual.
- If manual is lost, contact your nearest dealer for a new manual.

**⚠ DANGER**

**ROTATING BLADE HAZARD**

To prevent serious injury or death from Rotating blades:

- Do not go under frame when blades are turning or engine is running. Keep others away.
- Disconnect and lockout power source before adjusting or servicing.
- Keep hands, feet, hair and clothing away from moving parts.

**INSTRUCTIONS**

- READ MANUAL BEFORE OPERATING AND ADHERE TO ALL OPERATING, SERVICING AND SAFETY INSTRUCTIONS.
- PLACE TRACTOR LIFT IN FLOAT POSITION, STABILIZE LOWER LINKS, REMOVE DRAWBAR OR HEADSTAY.
- BE SURE THAT THE PTO TUBES ARE PROPER LENGTH FROM RAISED TO WORKING POSITION.
- GREASE ALL FITTINGS DAILY, PTO TWICE PER DAY, ON SIDE SHIFT MOOFLS, GREASE HEX SHAFT WEEKLY.
- DAILY CHECK OIL LEVEL IN THE GEARBOX (SEE 90 AND HANDWARE FOR TIGHTNESS, ESPECIALLY ON KNIVES. WEEKLY CHECK OIL CRACKS IN CHAINROD).
- TO REPLACE KNIVES, DO ONE AT A TIME, AND INSERT IN THE SAME PLACE AS THE ONE REMOVED.

**KEEP AWAY!**



Rotating DRIVELINE

**⚠ WARNING**

**AVOID INJURY FROM PTO**

- Entanglement can cause serious injury or death.
- Keep driveline shields in place & in good condition.
- Keep hands, feet, and clothing away.
- Operate only with 540 RPM.

right side

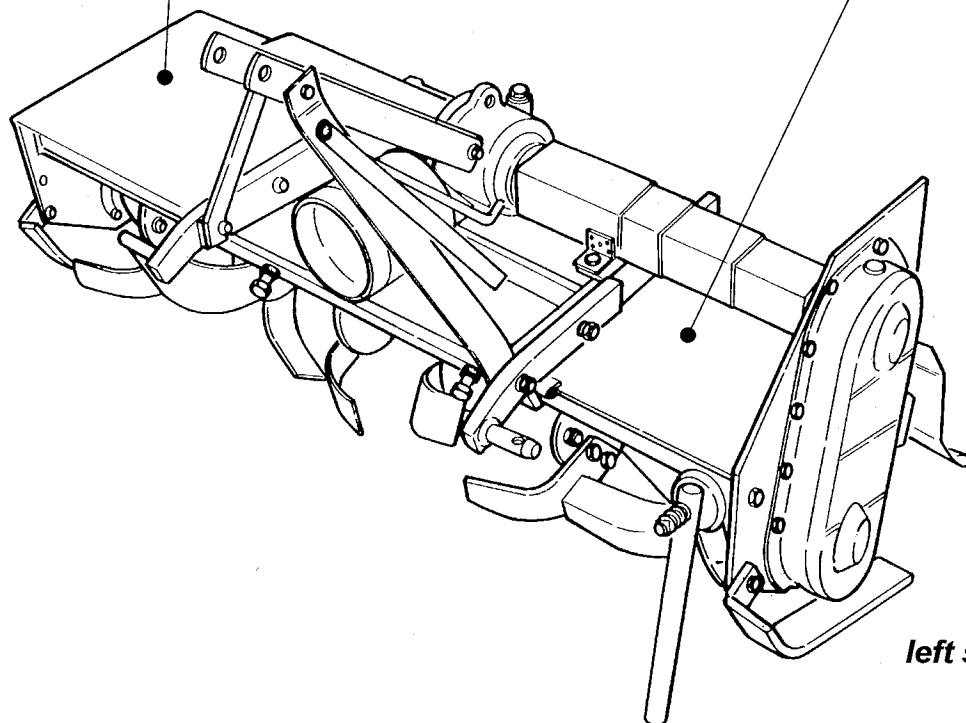

left side



## 3 - OPERATION

You have purchased a rotary tiller designed especially for landscaping, gardening, and tilling with small and medium sized tractors (20-40 HP) especially around fruit trees and in vineyards or greenhouses. It is an ideal machine for hobby farmer and landscaper. In fact, because of its side-shift capability, your tiller can be positioned to till next to trees and shrubs, along sidewalks, etc. It can also be shifted completely to the right in order to cover the right tractor tire tracks. This is particularly important when dealing with tractors equipped with especially wide tires. The working width is 42", or 66" depending on the model you chose.

The three point hitch can also remain positioned in the center to work like a normal center mount tiller. On your tiller, the tractor PTO transmits its power through a driveline to a speed reduction gearbox. This gearbox turns a hexagonal drive shift to which a chain sprocket is attached. A chain transfers power from the drive chain sprocket to a driven chain sprocket connected to a tilling bladed rotor. The rotor speed is set at the optimum speed to ensure ideal tillage conditions.

### 3.01 - Operational Safety



**CAUTION:** Our rotary tillers are designed considering safety as the most important target and are the safest available in today's market. Unfortunately, human carelessness can override the safety features built into our machines. Injury prevention and work safety, aside from the features on our tillers, is very much due to the responsible use of the equipment. It must always be operated prudently following with great care, the safety instructions laid out in this manual.



1. The use of this equipment is subject to certain hazards which cannot be prevented by mechanical means or product design. All operators of this equipment must read and understand this entire manual, paying particular attention to safety and operating instructions, prior to using.
2. Do not operate the tractor and tiller when you are tired, sick or when using medication.
3. Keep all helpers and bystanders at least several yards from a tiller. Only properly trained people should operate this machine.
4. When this machine is operated in populated areas where thrown objects could injure persons or property, standard equipment safety shielding (which is designed to reduce the possibility of thrown objects) must be installed.
5. The majority of accidents involve entanglements on the driveline, injury of bystanders by objects thrown by the rotating blades, and operators being knocked off the tractor by low hanging limbs and then being run over by the tiller. Accidents

- are most likely to occur with machines that are loaned or rented to someone who has not read the operator's manual and is not familiar with a tiller.
6. Always stop the tractor, set brake, shut off the tractor engine, remove the ignition key, lower implement to the ground and allow rotor to come to a complete stop before dismounting tractor. Never leave equipment unattended with the tractor running.
  7. Never place hands or feet under tiller's deck with tractor engine running or before you are sure all motion has stopped. Stay clear of all moving parts.
  8. Do not allow riders on the tiller or tractor at any time. There is no safe place for riders.
  9. Do not operate unless all personnel, livestock and pets are several yards away to prevent injury by thrown objects.
  10. Before backing up, disengage the tiller and look behind carefully.
  11. Install and secure all guards and shields before starting or operating.
  12. Keep hands, feet, hair and clothing away from moving parts.
  13. This tiller is designed for use only on tractors with 540 rpm power take off and in the power range between 20 and 40 HP.
  14. Never operate tractor and tiller under trees with low hanging limbs. Operators can be knocked off the tractor and then run over by the rotor.
  15. The rotating parts of this machine have been designed and tested for rugged use. However, they could fail upon impact with heavy, solid objects such as steel guard rails and concrete abutments. Such impact could cause the broken objects to be thrown outward at very high velocities. To reduce the possibility of property damage, serious injury, or even death, never allow the rotor to contact such obstacles.
  16. Frequently check blades. They should be sharp, free of nicks and cracks and securely fastened.
  17. Stop tiller immediately upon striking an obstruction. Turn engine off, remove key, inspect and repair any damage before resuming operation.
  18. Stay alert for holes, rocks and roots in the terrain and other hidden hazards. Keep away from drop-offs.
  19. Use extreme care and maintain minimum ground speed when transporting on hillside, over rough ground and when operating close to ditches or fences. Be careful when turning sharp corners.
  20. Reduce speed on slopes and sharp turns to minimize tipping or loss of control. Be careful when changing directions on slopes. Do not start or stop suddenly on slopes. Avoid operation on steep slopes.
  21. When using a unit, a minimum 20% of tractor and equipment weight must be on tractor front wheels. Without this weight, tractor could tip over, causing personal injury or death. The weight may be attained with a front end loader, front wheel weights, ballast in tires or front tractor weights. When attaining a minimum 20% of tractor and equipment weight on the front wheels, you must not exceed the ROPS weight certification. Weigh the tractor and equipment. Do not guess or estimate!
  22. Inspect the entire machine periodically<sup>2</sup>. Look for loose fasteners, worn or broken parts, and leaky or loose fittings.
  23. Use only the driveline supplied with the equipment. Do not use it if it is missing any shield or safety protection.

---

<sup>2</sup> See chapter 4 - Maintenance.

24. Pass diagonally through sharp dips and avoid sharp drops to prevent "hanging up" tractor and implement.
25. Avoid sudden starts and stops while traveling up or downhill.
26. Always use down slopes; never across the face. Avoid operation on steep slopes. Slow down on sharp turns and slopes to prevent tipping and or loss of control.

### 3.02 - Setup and Lubrication

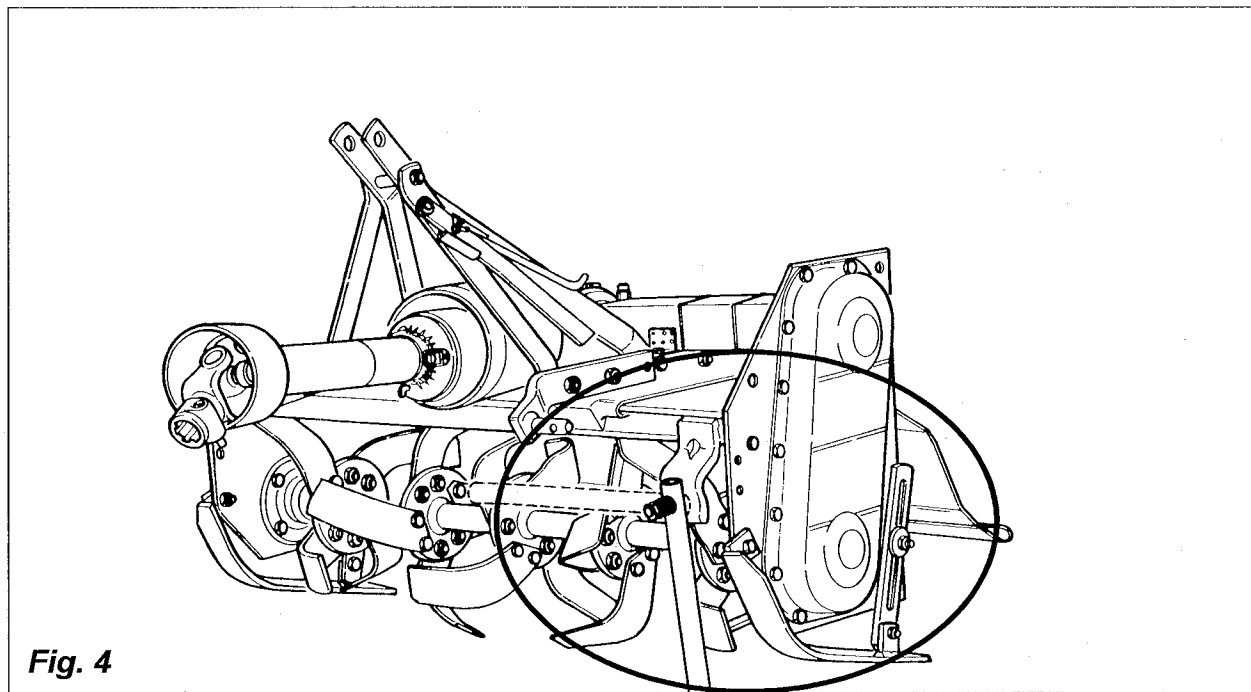
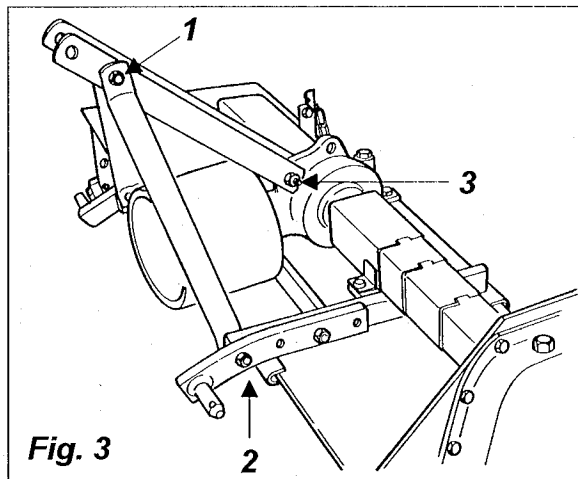

**CAUTION:** Stand clear of bands when cutting as they could be under sufficient tension to cause them to fly loose. Take care in removing bands and wire, they often have extremely sharp edges and cut very easy.

1. Disassemble top and sides of the crate. Cut wires holding driveline. Leave machine banded to pallet as long as possible to avoid tipping over during assembly.
2. Loosen bolts holding upper hitch mast in place in the shipping position.
3. Bolt the mast together (see fig. 3), and bolt it to the tiller<sup>3</sup>.
4. Be sure that the stand is held firmly in place, it should be able to swing down with the spring holding it in position to support the tiller without tipping over (see fig. 4).
5. Bolt the shifter arm (see #3, fig. 5) to the top hitch support (see #1, fig. 5) with the bolt and wing nut (see #2, fig. 5) provided.

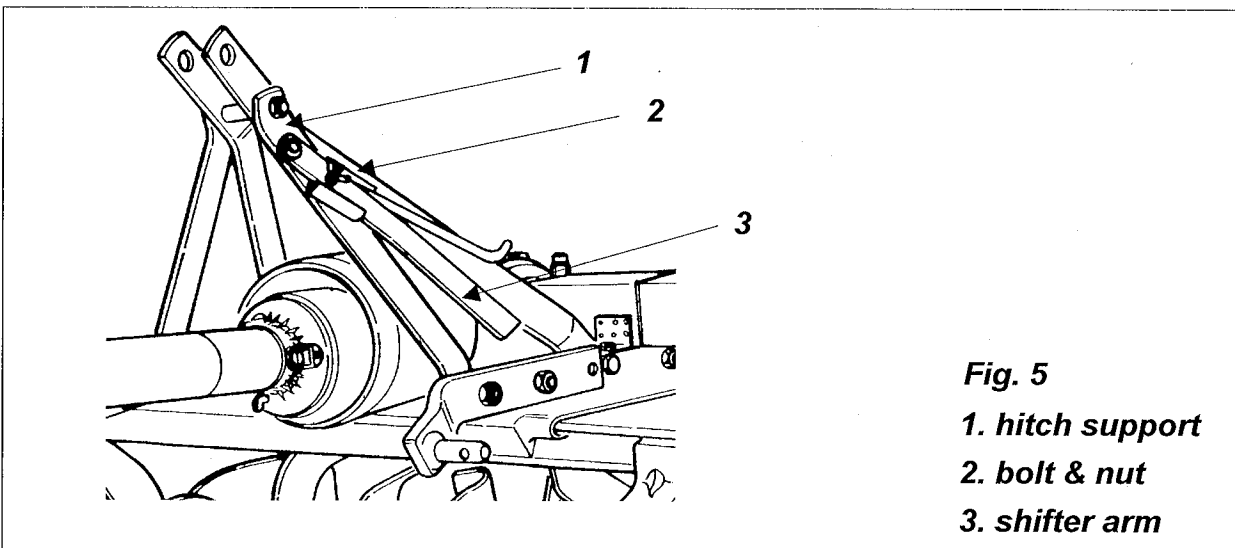

**Fig. 5**  
**1. hitch support**  
**2. bolt & nut**  
**3. shifter arm**

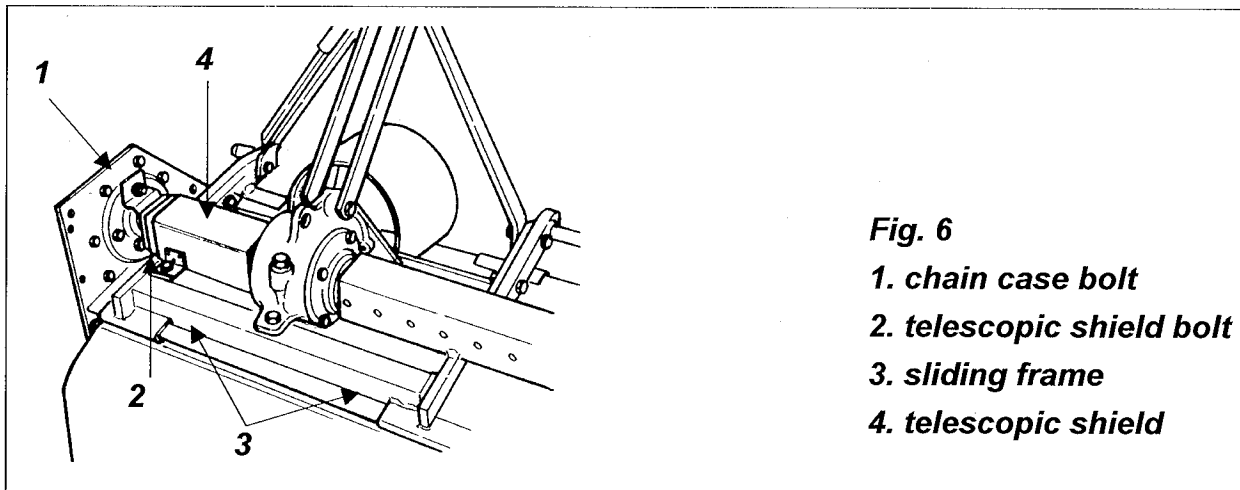

**Fig. 6**  
**1. chain case bolt**  
**2. telescopic shield bolt**  
**3. sliding frame**  
**4. telescopic shield**

<sup>3</sup> See table 1, page 26.

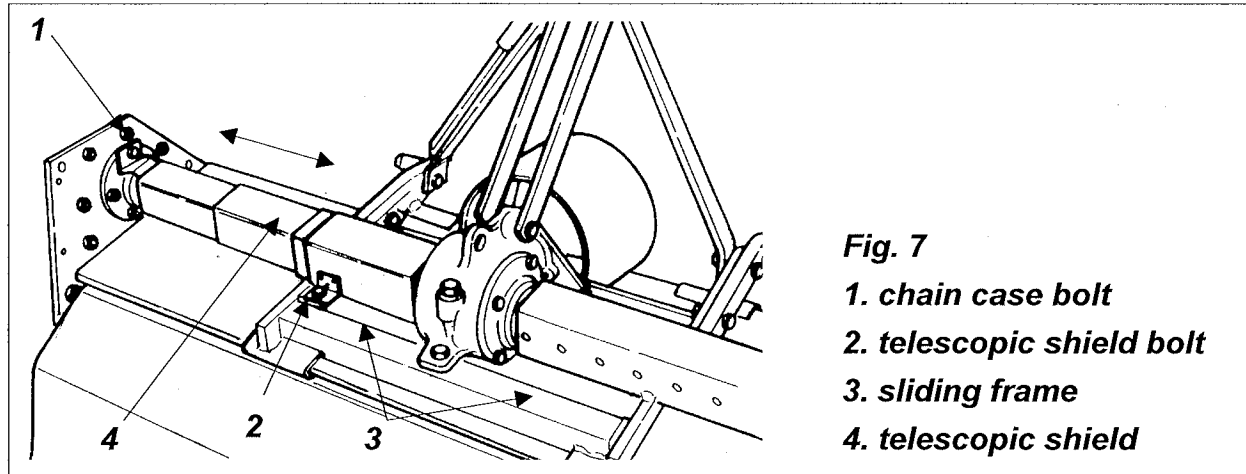

Fig. 7

- 1. chain case bolt
- 2. telescopic shield bolt
- 3. sliding frame
- 4. telescopic shield

6. Be sure that the breather plug is screwed into the chain case. Check the gearbox oil level. It should be between  $\frac{1}{2}$  and  $\frac{2}{3}$  full. Use SAE 90.
7. Check all hardware for proper torque.
8. After shifting the side shift into its desired position, block it into position with the locking bolts<sup>4</sup>.
9. Grease driveline cross and bearing assemblies. Grease sliding sections of shaft.
10. The hexagonal drive shaft is protected by a telescopic sliding shield (see #4, fig. 6 & 7). To attach this shield do the following: bolt the upright tab to the chain case side plate (see #1, fig. 6); open the telescopic shield and bolt the outer cover (see #2, fig. 7) to the retaining plate on the sliding frame (see #3, fig. 7); ensure that the telescopic shielding (see #4, fig. 7) when open does not touch the hexagonal shaft and is as parallel as possible; slide the frame (see #3, fig. 7) back two or three times from completely open to completely closed to be sure it opens and closes without difficulty. **Note: lightly greasing the hexagonal drive shaft helps the side shifting of the tiller.**
11. Grease right rotor support bearing (see #1, fig. 8).
12. Hook up the rear shield adjustment chain as follows: slip one end of the chain (#5 fig. 8) through the 'U' bolt (#2, fig. 8) and then bolt it to the rear shield in the predisposed holes. Bolt the other end of the chain to the chain hitch located on the tiller frame (#3, fig. 8). Ensure it is tightened properly. The chain hitch also works as a stop for the sliding frame to limit its travel.

**Notice to the dealer:** Pre-delivery setup and service including lubrication is the responsibility of the dealer. It is up to him to assure that the machine is in perfect condition and ready to be used. It is his responsibility to ensure that the customer is aware of all safety aspects and operational procedures for the tiller. He must also fill out the Pre-delivery Checklist<sup>5</sup> prior to delivering the tiller.

<sup>4</sup> See paragraph 3.03 - Side Shift.

<sup>5</sup> See chapter 7 - Pre-delivery Checklist.

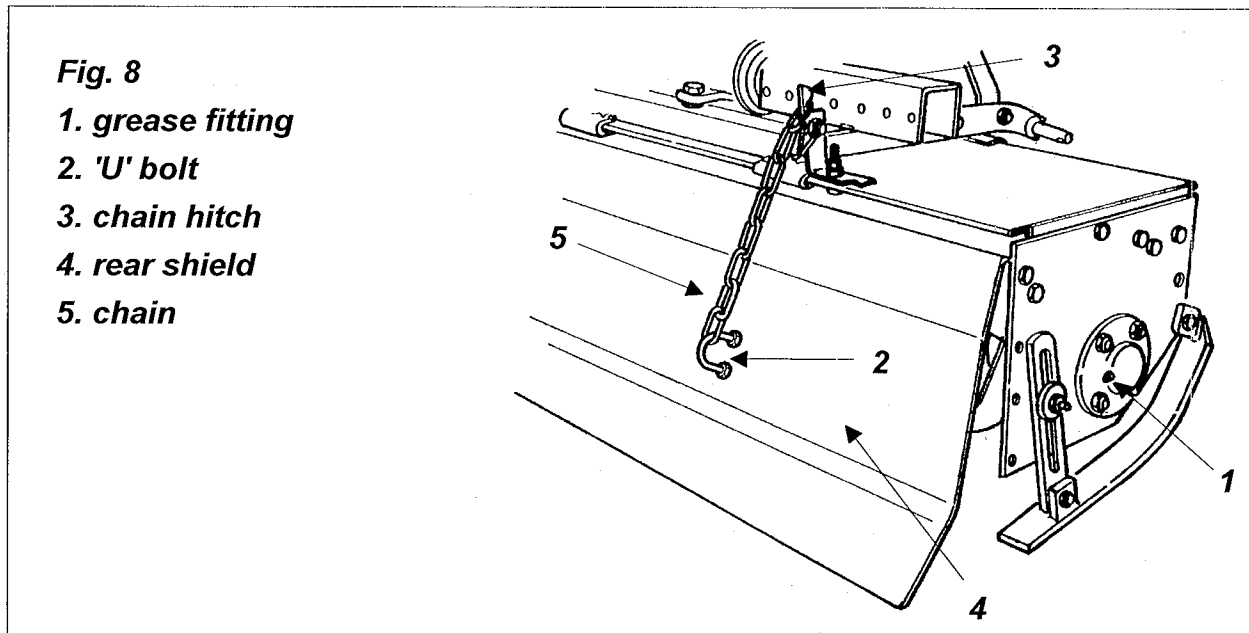

### 3.03 - Side Shift

To side shift the tiller from the center mount position, do the following:

1. Loosen the two locking nuts (see #1, fig. 9) and loosen the two bolts (see #2, fig. 9) of the 3 point hitch sliding frame. Do not remove the bolts.
2. Slip the shifting lever over the bolt (see #2, fig. 10).
3. Insert the hooked rod end of the handle in one of the holes (see #3, fig. 10) on the rear of the hexagonal drive-shaft protection (see #4, fig. 10).
4. Push or pull the handle and keep placing the hook rod in the next hole until the machine is shifted to the desired position.
5. Replace the pivoting shift handle to its mounting place (see #1, fig. 10).
6. Re-tighten bolts and locking nuts of the 3 point hitch sliding frame (see #1 & 2, fig. 9).

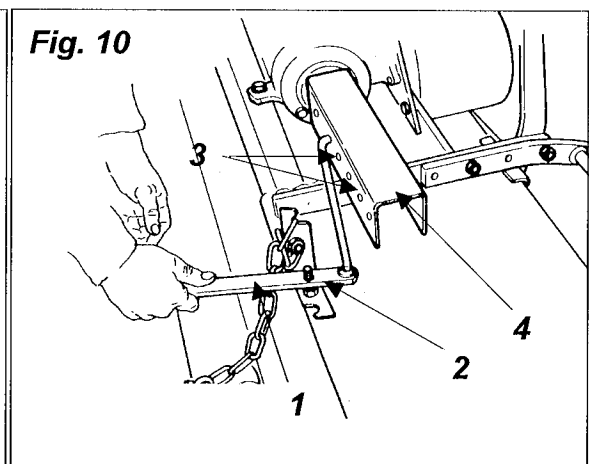
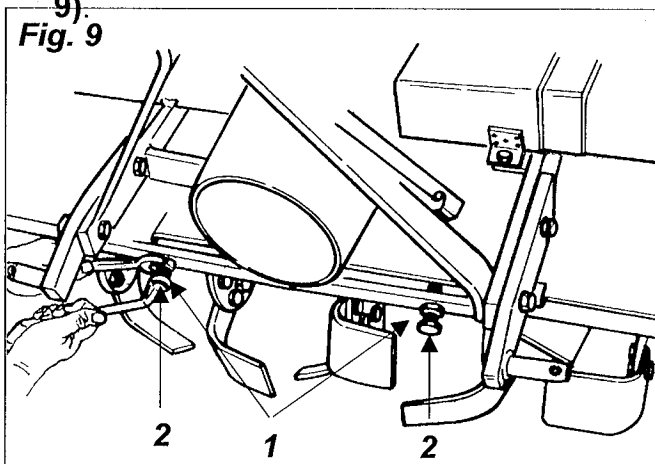

### 3.04 - Depth Control

The tilling depth is at its maximum when the skids are touching the side plates. The more they are lowered the shallower the tiller works. Thus the tilling depth is controlled by raising and lowering the side skids.

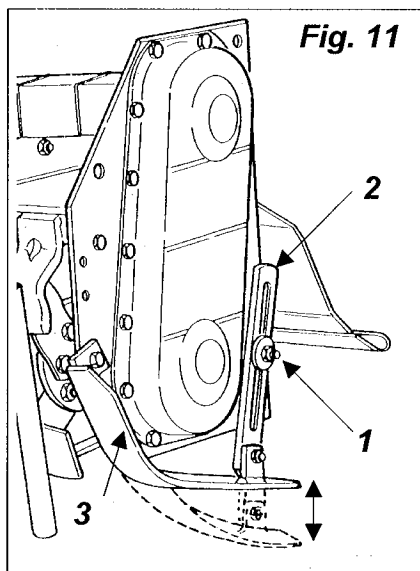

To do this:

1. Loosen the nut (see #1, fig. 11) on the adjustment arm.
2. Place the skid (see #3, fig. 11) in the desired position.
3. Re-tighten the nut (#1) on the adjustment arm (#2).
4. Repeat this operation on the other skid, ensuring both skids are level.

### 3.05 - Rear Shield Adjustment

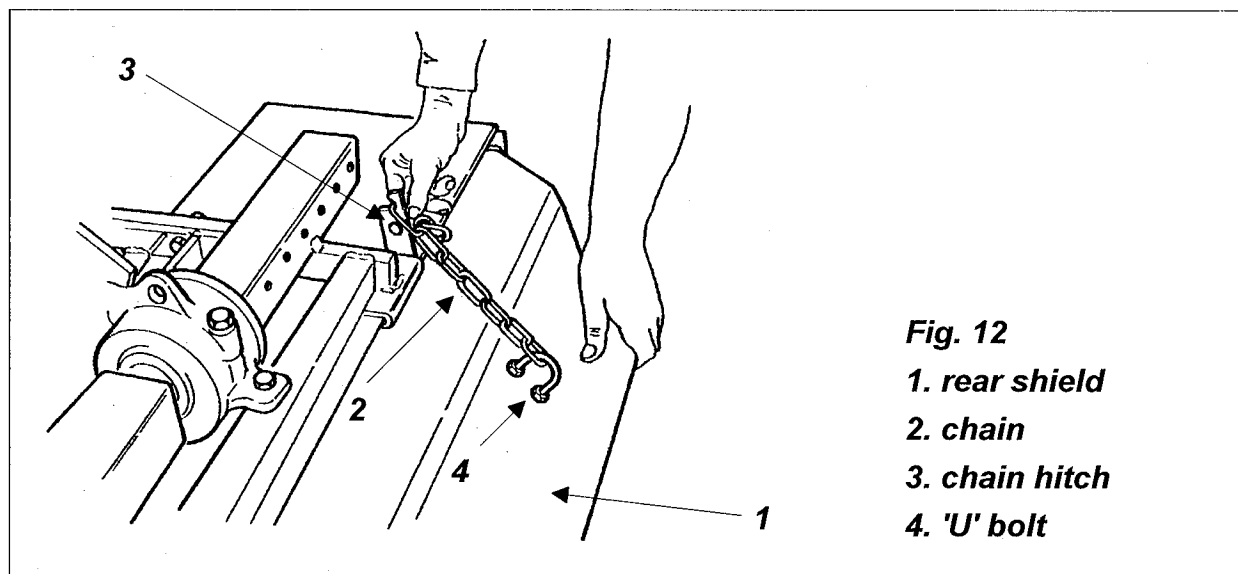

Fig. 12

1. rear shield
2. chain
3. chain hitch
4. 'U' bolt

The rear shield, for safety reasons, must always remain in contact with the ground. This also ensures better pulverization of the soil and helps level it out.

Raise rear shield (see #1, fig. 12) to the desired position. Hook the chain (see #2, fig. 12) to the chain hitch (see #3 fig. 12).

### 3.06 - Pre-Operational Check

Check each of the following carefully prior to engaging the equipment:

1. The rotor bearing has been greased and the drive chain is lubricated.
2. The oil in gearbox is between  $\frac{1}{2}$  and  $\frac{2}{3}$  full.
3. The driveline cross & bearings have been greased.
4. No wrappings or foreign objects are on the machine or driveline.
5. The blades are properly installed and the blade bolts and nuts properly torqued<sup>6</sup>.
6. All hardware is tight.
7. Check the tractor to ensure correct direction of PTO and rpm speed.
8. Ensure all safety shields and guards are in there place and tightly attached.
9. No people or animals are in the work area.
10. When working, make sure the tractor hitch is in the "float" position, in order to allow the tiller to follow the contour of the ground.



**CAUTION:** Engage the tractor PTO only when the tiller blades are 1.5" to 2" from the ground.



**WARNING:** Stay clear of rotating driveline. Entanglement in rotating driveline can cause serious injury. Disengage PTO, engage parking brake or place transmission in "Park", shut off the tractor and remove the key before working around hitch, attaching or detaching driveline, making adjustments, servicing or cleaning the machine.

### 3.07 - Attaching to the Tractor

Unit may be used on tractors with HP ranging from 20 to 40 and equipped with a standard rear PTO and Cat. 1 three point hitch<sup>7</sup>.



**CAUTION:** Check the tractor PTO rpm to ensure it is set at 540 and turns clockwise. Always ensure that the tractor tire pressure is correct according to the tractor operator's manual.

<sup>6</sup> See table 1, page 26.

<sup>7</sup> See table 2, page 26.





**WARNING:** Disengage PTO, wait for all movement from the implement and tractor to stop, engage parking brake or place transmission in "Park", shut off the tractor and remove the key before attaching the implement to the tractor.

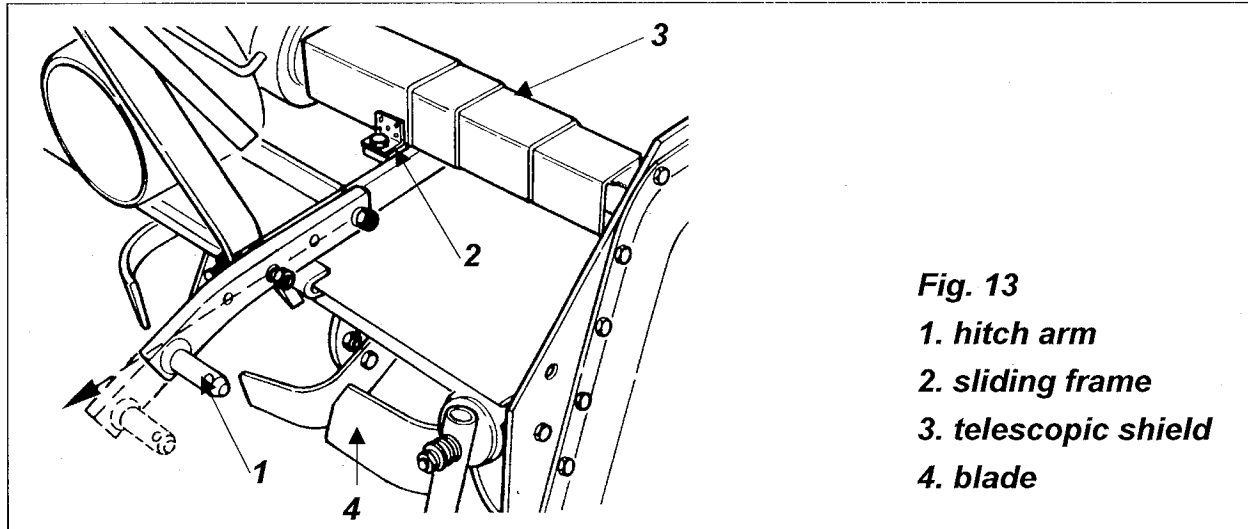

**Fig. 13**

- 1. hitch arm
- 2. sliding frame
- 3. telescopic shield
- 4. blade



**DANGER:** Tractor-implement combinations can create unstable unions with a chance of roll over. If necessary, front weights need to be added to the tractor in order to maintain balance. Always ensure that the tractor tire pressure is correct according to the tractor operator's manual.

**Fig. 14**

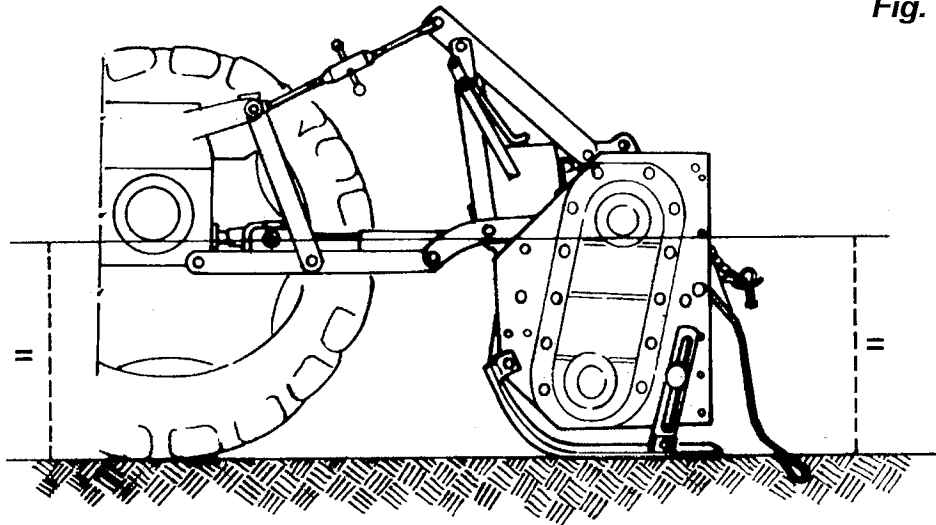

To attach the tiller to the tractor do the following:

1. Back the tractor up to the machine in order to slip the tractor hitch arms over the hitch pins welded to the tiller hitch arms. **Turn off the tractor engine.**
2. The tiller hitch arms are adjustable in and out and may be positioned turned up or down, depending on driveline length and tractor size (**see fig. 14**).
3. Lock the tractor arms to the tiller hitch arms with the lynch pins. Stabilizers must be used to limit side swing to 2"-3".
4. Attach the top link. Adjust it so the tiller is as near parallel to the ground as possible. A 1 to 2 degree rearward tilt is acceptable (**see fig. 14**).
5. Install the shielded driveline to the tractor by first lining up the splines and depressing the snap pin. Push the yoke onto the PTO shaft as far as it will go. Release the pin and pull back slowly until the pin clicks in place. Repeat this operation on the implement end.
6. Attach the driveline chains to the tractor and to the machine to keep the driveline protection from turning. The chains should not be too tight. **Reinstall sheet metal protection.**

### 3.08 - Start Up



**DANGER:** Never allow anyone around the tiller when it is in operation. Never engage the tractor PTO before the tines are about to touch the ground.



**DANGER:** Operate the implement only at the speed and direction of rotation indicated on the machine. Serious damage can result if this is not followed.



**CAUTION:** Before starting work, clear the area of any obstacles or foreign objects.

Begin tilling at the lowest ground speed possible, increasing until the desired speed is reached. Engage the PTO with the tiller just clear of the ground. Open the throttle to  $\frac{3}{4}$  of its full power speed and lower the tiller into the ground. Open up the throttle to full power. **Avoid working in reverse.**

Before beginning work always remember that the operator is responsible for:

1. Safe and correct operation of the tractor and tiller.
2. Learning and following precise, safe operating procedures for both the tractor and the tiller.
3. Ensuring all maintenance and lubrication has been performed on the tiller.
4. Having read and understood all safety aspects for the tiller in the operator's manual.
5. Having read and understood all safety decals on the tiller.
6. Checking the condition of the blades. Worn or damaged blades should be changed before starting.

7. Checking to ensure that the cutting edge is the leading edge of the blade.
8. Checking that there are no wires, weeds, grasses or other objects wrapped around the rotor.
9. Checking to see if front weights need to be added to the tractor in order to maintain balance.
10. Checking the tractor tires for the proper pressure in accordance to the tractor operator's manual.
11. Checking that all shielding is on the machine and securely in place.
12. Making sure the proper attire is worn. Avoiding loose fitting clothing which can become entangled. Wearing sturdy, tough-soled work shoes and protective equipment for eyes, hands, ears and head. Never operate tractor or implements in bare feet, sandals or sneakers.
13. Checking area for stones, branches and other debris that might be thrown.
14. Ensuring proper lighting is available, sunlight or good artificial lighting.



**DANGER:** Never use the machine without first assuring all protective devices are properly installed.



**CAUTION:** For emergency reasons, learn how to stop the tractor and implement quickly. Always disengage the PTO, lock parking brake, stop engine and allow the blades to come to a complete stop before dismounting the tractor.



**WARNING:** Do not allow the tractor rpm to go below full throttle when working. This can cause damage to your tractor.

### 3.09 - Test Run

After running the tiller 120-150 ft., raise the machine and just as the blades lift up from the soil, disengage the PTO, lower the tiller and shut off the tractor engine. Assure that the machine is properly adjusted and functioning properly. After the first five minutes of operation, stop and feel the gearbox. It should be warm to the touch; not hot.



**WARNING:** Never operate without all shields on the machine and securely in place. The tiller blades can throw objects which could result in personal or property damage. Enter new areas carefully.

### 3.10 - Working Depth

Depth of cut is determined largely by the condition of the ground. When working hard or previously unworked ground, set depth at no more than 2"-3". Greater depth may require a second pass.

**NOTE: Excessive vibration or jumping of the machine is an indication that the machine is working too deep for conditions, such as in hard, parched or compacted soil and should be adjusted accordingly.**

### 3.11 - Working Speed

Ground speed is determined by the soil condition, depth of cut and tractor power. Simple experimentation will soon determine the best speed for the desired results, usually 1 to 2 mph.

### 3.12 - Finer Pulverization

A slow ground speed will result in a finer soil, as a faster ground speed will render the opposite. The rear shield, besides being a safety device, will help in producing a finer worked soil. Test results show that a raised shield will leave a coarser finished surface.

### 3.13 - Headland Procedure

When the headland is reached, it is important that the following be observed:

1. Raise the machine from the ground and as soon as the blades leave the ground, disengage the tractor PTO.
2. Turn the tractor facing the new desired direction of travel.
3. Begin working again<sup>8</sup>.

**NOTE: Best practice dictates that the machine be lifted no more than just enough to clear the ground. Running the machine at an extreme angle could damage the PTO.**

### 3.14 - Working Limitations

If the tiller won't penetrate the ground easily, conditions may be too dry, tough or compacted. Also assure that the blades are properly installed with the proper scroll (see **fig. 18**). This condition is evidenced by vibration and jumping of the machine.

The combination of excessively hard ground and rocky conditions will greatly reduce the life of the blades. Under these extreme conditions it may be wise not to use the tiller as primary tillage tool, thus running over the ground with a disc or plow prior to tilling is advised.

---

<sup>8</sup> See paragraph 3.06 - Pre-Operational Check.

### 3.15 - Uneven Terrain



**DANGER:** Be careful when operating tractor and machine over uneven ground to avoid roll-over. In extremely uneven terrain rear wheel weights, front tractor weights and/or tire ballast should be used to improve stability.

When working over uneven terrain, observe the type of terrain and develop a safe travel pattern. Whenever traction or stability is doubtful, first test drive over the terrain with the PTO disengaged.

Operate the machine up and down steep slopes, not across slopes, to prevent the tractor from tipping. Avoid sudden stops and starts and slow down before changing directions on a slope. Pass diagonally through sharp dips and avoid sharp drops to prevent hanging up the tractor and machine. Slow down on sharp turns and slopes to prevent tipping or loss of control. Avoid tipping the machine while working. Watch for holes, roots or other hidden objects. Do not work near the edge of a gully, ditch or stream bank.

### 3.16 - Transport



**CAUTION:** All transport operations are to be done without the tiller working, and respecting all local traffic rules and regulations.

During transport or when the machine is lifted from the ground, it is advisable to adjust the tractor lift arms in order to be able to raise the machine 14"-16" from the ground (see fig. 15).

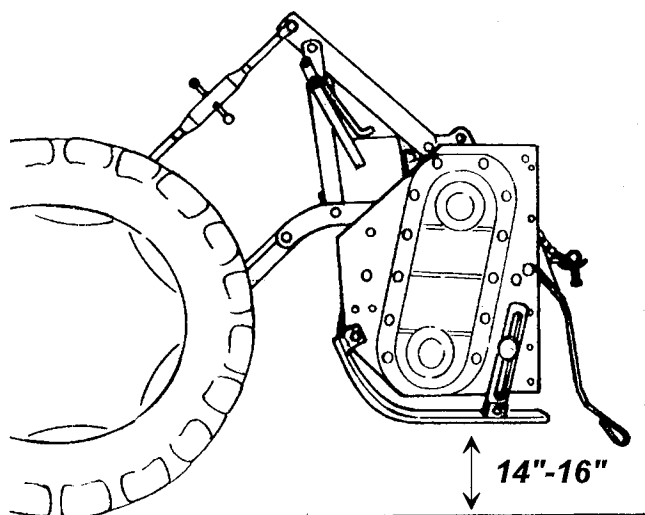

**Fig. 15**  
Raise the machine 14"-16" from the ground during transport.

## 4 - MAINTENANCE



**DANGER:** Stop engine, lock parking brake and remove key before performing any service or maintenance.

Never rely on the tractor lift system. Install blocks or stands under the machine to prevent it from falling. Always use personal protection devices, such as glasses or gloves when performing maintenance.

Keep fingers out of slots to prevent injury.

### 4.01 - Maintenance Safety



1. Good maintenance is your responsibility.
2. Keep service area clean and dry. Be sure electrical outlets and tools are properly grounded. Use adequate light for the job at hand.
3. Make sure there is plenty of ventilation. Never operate the engine of the towing vehicle in a closed building. The exhaust fumes may cause asphyxiation.
4. Make no repair or adjustments with the tractor engine running. Before working on the machine, disengage the PTO, shut off the engine, set the brakes, and remove the ignition key.
5. Be certain all moving parts on attachment have come to a complete stop before attempting to perform maintenance.
6. Never work under equipment unless it is blocked securely.
7. Always use personal protection devices such as eye, hand and hearing protectors, when performing any service or maintenance.
8. Frequently check blades. They should be sharp, free of nicks and cracks and securely fastened.
9. Periodically tighten all bolts, nuts and screws and check that all cotter pins are properly installed to ensure unit is in a safe condition.
10. When completing a maintenance or service function, make sure all safety shields and devices are installed before placing unit in service.
11. After servicing, be sure all tools, parts and service equipment are removed.
12. Never replace hex bolts with less than grade five bolts unless otherwise specified, i.e. shear bolts<sup>9</sup>.
13. Where replacement parts are necessary for periodic maintenance and servicing, genuine replacement parts must be used to restore your equipment to original specifications. The company will not claim responsibility for use of unapproved parts and/or accessories and other damages as a result of their use.

---

<sup>9</sup> Refer to table 1 - Torque Specifications, for head identification marking.

14. Unauthorized modifications to the machine may impair the function and/or safety of the machine and reduce its life. If equipment has been altered in any way from original design, the manufacturer does not accept any liability for injury or warranty.

## 4.02 - Service

The list below gives the frequency of lubrication in hours, based on normal operating conditions. Severe or unusual conditions may require more frequent lubrication.

Use a good quality SAE multipurpose type grease for all locations shown. Be sure to clean fittings thoroughly before using grease gun.

Use 90 wt. or 140 wt. gear oil in gearbox.

1. **Hourly:** remove any wrapping (stalks, weeds, trash, etc.) from tiller, especially from around bearing supports on the rotor ends.
2. **Every four hours:** ensure bolts holding the side shift are tight.
3. **Daily:** ensure blades are not broken and bolts are tight. Grease the rotor support, the driveline cross & bearings and telescopic tubes. Check the gearbox for oil level.
4. **Weekly:** check the blades for excessive wear or damage. Ensure the rotor turns freely. Look at the chain in the chain case and make sure it is well lubricated.
5. **After the first 200 hours:** remove the chain case cover (being sure not to damage the gasket), clean the chain sprockets with kerosene, replace the sprockets and reassemble using fresh GP Grease (approximately 2.2 lb.).

## 4.03 - Blade Maintenance



**WARNING:** Avoid possible injury, wear proper eye and hand protection when servicing tiller blades.

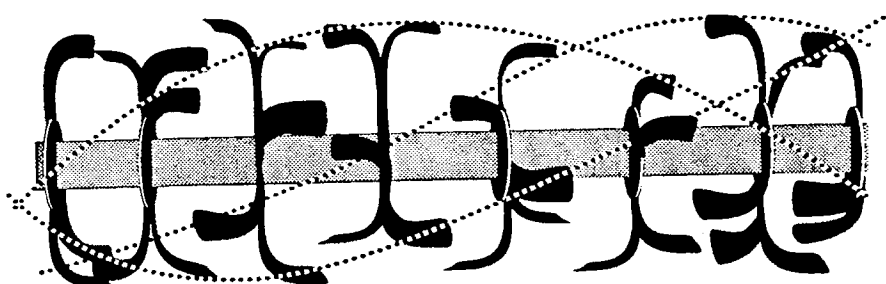

Fig. 16

It is important to change blades after they have worn down 1-1/4" from their original length. When replacing blades, it is best to replace them one at a time to maintain the original scroll pattern. If, however, it becomes necessary to remove them all, **it is essential to maintain the scroll pattern of the blades (see fig. 16)**. To do this, remove one blade and immediately replace it with a new one. Be sure the bolt head (see #3, fig. 17) is touching the blade (#4), while the washer (#5) and nut (#6) contact

the flange. Sometimes a locknut is used instead of a lockwasher and nut. Proceed until all blades needed to be changed are changed.

After putting on the new blades, tighten the nuts to their proper torque specifications.

To determine if a blade is right or left, do the following:

1. Hold the blade in the palm of the hand with the bend pointing upward.
2. If the cutting edge points toward the right then the blade is right-handed.
3. The cutting edge pointing to the left indicates a left-handed blade.

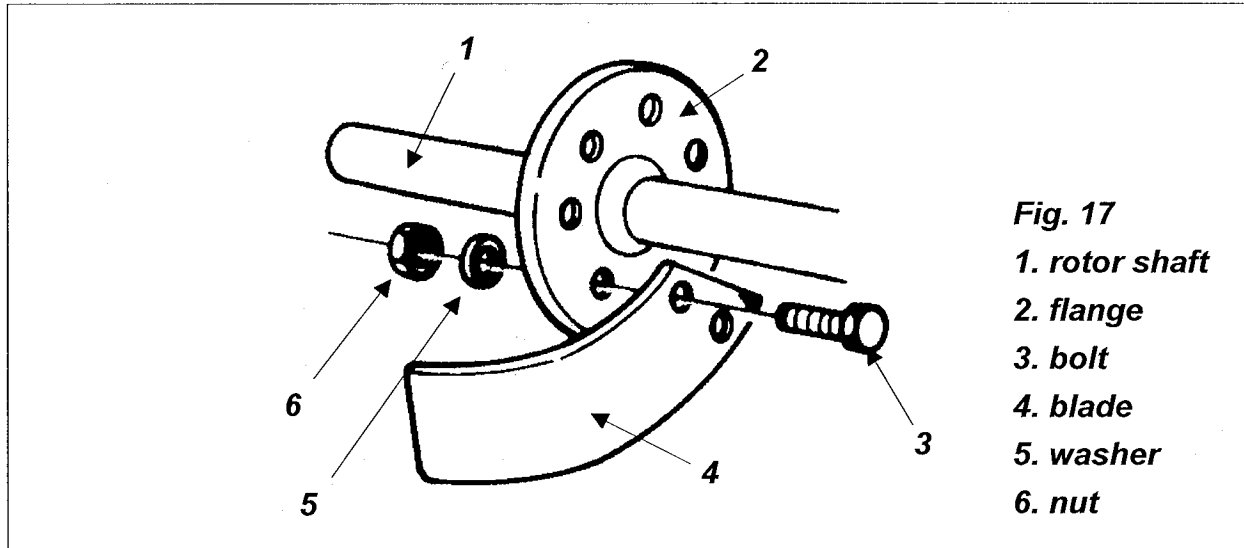

**Fig. 17**  
 1. rotor shaft  
 2. flange  
 3. bolt  
 4. blade  
 5. washer  
 6. nut

#### 4.04 - Driveline



**DANGER:** Only use the original driveline supplied with this tiller and always with the safety shielding in place.

Carefully read and file away the driveline operator's manual supplied by the manufacturer. The following does not substitute the information found in the driveline manual.

In the collapsed position the driveline should be approximately 2" from bottoming out to prevent possible damage to the tractor or implement. When the PTO is in the maximum extended position, the ideal minimum overlap of the two halves should be approximately 6" (see fig. 18).

If determined that the driveline is too long. Follow these procedures to adjust the length:

1. Separate the two driveline halves. Connect one half to the tractor PTO and the other half to the tiller.



2. Raise and lower the machine with the 3 point hitch to find the position where the driveline is shortest. Hold the half shafts side by side and mark the desired length on the outer female guard tube leaving a 2" gap between the end of the guard tube and bell guard.
3. Cut off both guard tubes the same amount as marked in step 2.
4. Shorten both drive tubes the same amount as guard tubes.
5. De-burr and clean filings from drive tubes and apply grease to outside of inner telescoping tube.

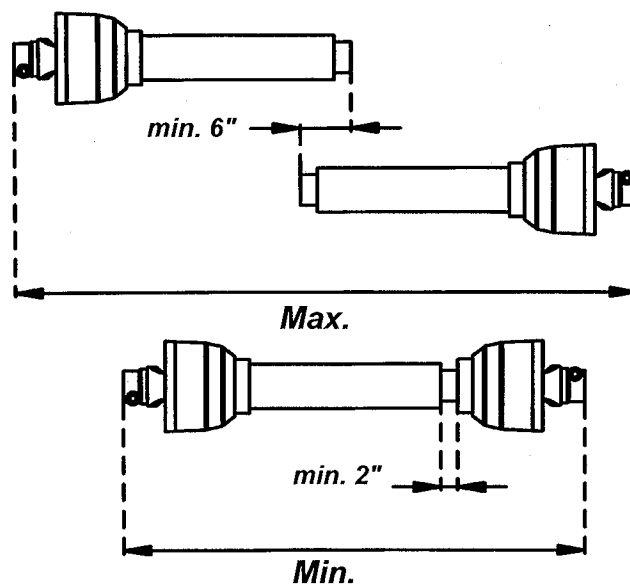

Fig. 18

Reassemble the driveline halves and connect to tractor and tiller. Raise and lower tiller again to be sure driveline does not bottom out in shortest position and has a minimum overlap of 6" in the longest position.



**CAUTION:** Always work with the driveline as straight as possible. This will prolong its life and that of its components. It is advised, not to work at an angle greater than 15 degrees.

#### 4.05 - Safety Shear Pin Coupler

In the case of a shear pin breaking (the operator will notice that the tiller will stop even though the tractor PTO is still engaged), disengage the PTO, stop and turn off the tractor. **Replace the broken shear bolt with another having the identical characteristic of the original (see fig. 19).**

Substituting different shear bolts other than those indicated by the manufacturer can render the safety inoperable.

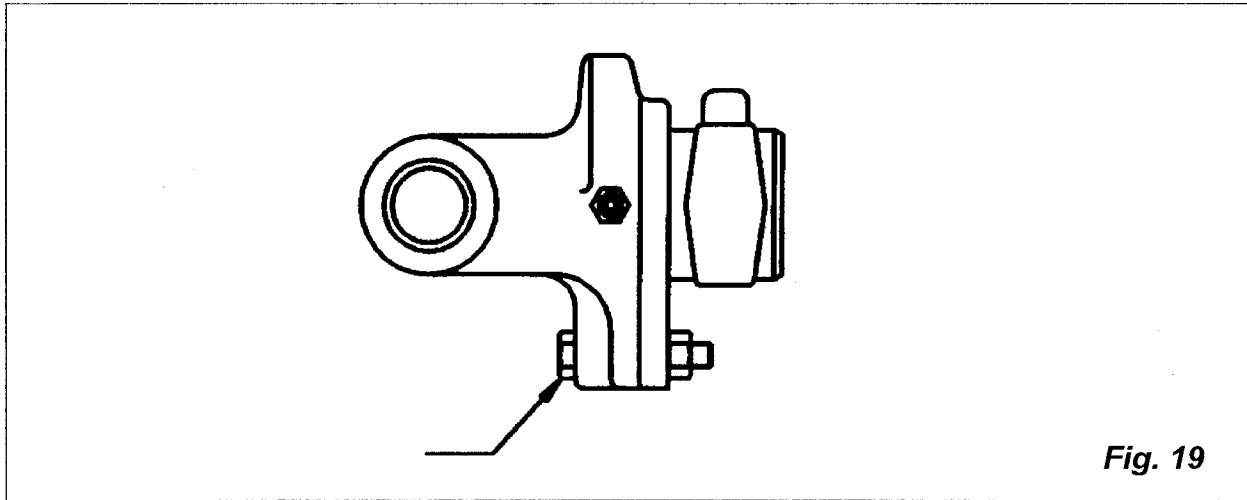

Fig. 19

#### 4.06 - Safety Slip Clutch

When the tiller is supplied with a safety slip clutch, it is important to ensure it is working properly. The slip clutch delivered with your machine is set at a specific torque for normal working conditions.

If while working, the clutch slips frequently, the spring nuts need to be tightened  $\frac{1}{2}$  turn. Check the clutch after 600-800 ft, if necessary repeat the operation. If after tightening the nuts down and the clutch continues to slip, the discs will have to be replaced (**see fig. 19**).

Follow the instructions in reverse, if while working under normal conditions the clutch does not slip at all.

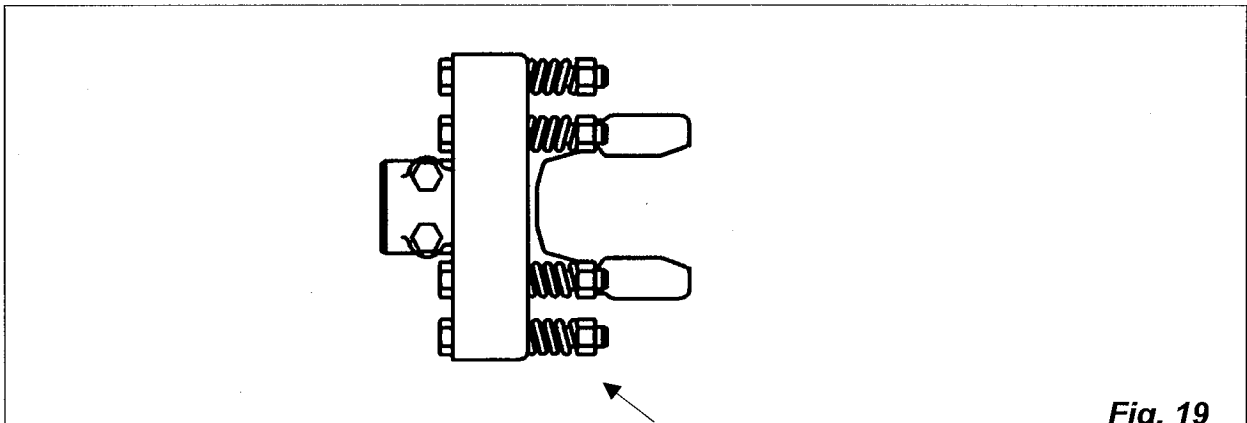

Fig. 19

**TABLE 1 - TORQUE SPECIFICATIONS**

Diameter	Class 8.8		Class 10.9	
	N.m	lb.ft	N.m	lb.ft
M 8	25	18	35	26
M 10	50	37	70	52
M 12	90	66	125	92
M 14	140	103	200	148
M 16	215	155	305	225
M 18	295	217	420	309
M 20	420	302	590	438

When using locking nuts, increase torque values by 5%.

**TABLE 2 - ROTARY TILLER - TECHNICAL FEATURES**

For tractors up to 40 HP, PTO 540 rpm, three point hitch cat. 1.										
Model	Working width	Total width	Weight lb.	Side shift	# of flanges	# of blades	Rotor rpm	Sprockets	Working depth	Driveline 1 3/8"
RT42	42	47"	373	10"	5	20	231	11-14	7,2"	BT (3)
RT66	66"	72"	492	22"	8	32	231	11-14	7,2"	BT (3)

## 5 - REPAIR PROCEDURES



**CAUTION:** It is not recommended that untrained individuals perform any repair work. The following operations are detailed for qualified personnel only.

### 5.01 - Gearbox

To remove the gearbox from the side shift frame proceed as follows:

1. Remove the rear bolt holding the gearbox to the side shift frame
2. Slide the side shift frame over until the gearbox is off the hexagonal shaft.
3. Unbolt the bolts holding the front plate to the side shift frame.
4. Whenever the bearings are removed from the gearbox, all **oil seals should be replaced** to assure no leaks when the box is reassembled.
5. To avoid damage to components, bearings should always be removed with bearing pullers and pressed in when being replaced.
6. When reassembling the gearbox, ensure that there is precise mesh between ring and pinion gears.

### 5.02 - Chain Case

To remove the chain do the following:

1. Unbolt chain case cover.
2. Remove the chain case cover taking care not to damage the gasket.
3. Release the automatic chain tensioner spring.
4. Remove the two snap rings holding the chain sprockets
5. Slip off both chain sprockets at the same time.

To replace the chain follow the procedure in reverse order, ensuring the gasket is not damaged. If damaged it must be changed.

### 5.03 - Rotor

To remove the rotor and rotor supports do the following:

1. Remove the chain and chain sprockets.
2. Unbolt the bolts holding the left rotor support.
3. Unbolt the bolts holding the left side panel.
4. Unbolt the bolts holding the right side panel and slip the rotor out of the rotor supports.

### 5.04 - Suggested Spare Parts

It is suggested that the following spare parts be kept on hand all times to prevent a minor problem from delaying work:

Description	Quantity
Right hand blade	6
Left hand blade	6
Blade bolt	12
Blade nut and washer	12
Shear bolt complete	12
Chain	1

### 5.05 - Storage

After seasonal use it is important to perform the following for prolonged storage:

1. Wash the tiller carefully.
2. Inspect the machine, replace worn and damaged parts.
3. Tighten all hardware. Grease all areas indicated under maintenance.
4. Cover the tiller from the elements in order to have it in perfect condition for the start of the next season.

## 6 - TROUBLESHOOTING



**WARNING:** Stop engine and allow the tiller blades to come to a complete stop before making any adjustments or repairs on the tiller.

PROBLEM	POSSIBLE CAUSE	SOLUTION
Machine makes intermitting clicking noise.	Loose blade bolts. Gearbox gears or chain damaged.	Tighten blade bolts. Replace damaged gears or chain.
PTO vibrates.	Worn cross & bearings.  Driveline working at too great of an angle. Wrappings around rotor shaft.	Replace worn cross and bearings. Reduce the working angle of the driveline. Check for wrappings on rotor shaft.
Gearbox noise is noticeable and constant.	Oil level low.  Worn Gears.	This can be normal on a new machine until it has been run in. Check oil level. Replace worn gears.
Blades stop turning but PTO, gearbox and hexshaft are.	Broken drive chain.	Remove chain case and check for broken connector link.
PTO turning but not blades.	Broken shear bolt.	Check shear bolt. If sheared, replace it.
Machine skips and leaves crop residue.	Worn blades.  Ground speed too fast.	Check for badly worn blades. If worn down to tip, overlap will be lost and cutting will deteriorate. Replace worn blades. Reduce ground speed.
Machine smells hot or begins to smoke.	Wrappings around rotor.  Gearbox oil low.	Can be caused by friction from trash heavily wrapped around bearing protection covers. Remove trash immediately, as damage to bearing could result. Check oil level in gearbox and lubricant on chain.
Oil leak from gearbox.	Oil seal or grease fitting damaged. Gearbox overfilled.	Replace oil seal or grease fitting. Remove excess oil.

## 7 - PRE-DELIVERY CHECKLIST

**To the dealer: Inspect the machine thoroughly after assembly to assure it is functioning properly before delivering it to the customer. The following checklist is a reminder of points to cover. Check off each item as it is found satisfactory or after proper adjustment is made.**

- Gearbox oil level.
- Guards and shield properly fastened.
- Lubrication of grease fittings.
- All hardware properly tightened.
- All decals properly located and readable (**see fig. 2**).
- Blades properly installed, blade bolts & nuts tightened.
- Overall condition (touch up scratches, clean and polish).
- Test run, check for excessive vibrations or overheating of bearings.
- Operator's Manual.

**Review the operator's manual with the customer. Explain the following:**

- Warranty.
- Safe operation and service.
- Correct machine installation and operation.
- Daily and periodic lubrication, maintenance and inspections.
- Troubleshooting
- Operational procedures and storage.
- Parts and service.
- Remove and fill out the Delivery and Warranty Registration form.
- Give customer the operator's manual and encourage the customer to read the manual carefully.

**IMPORTANT: Warranty is not valid unless Delivery and Warranty Registration Form in operator's manual is completed in detail and mailed to the Company.**

Model Number: \_\_\_\_\_ Serial Number: \_\_\_\_\_

Delivery Date: \_\_\_\_\_ Dealer's Signature: \_\_\_\_\_





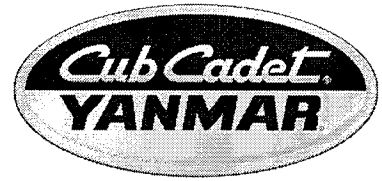

## **8 - PARTS MANUAL**

# ***Rotary Tiller 42" & 66"***

---

# ***RT42***

# ***RT66***

Cub Cadet Yanmar LLC.  
P.O. Box 368023  
Cleveland, OH 44136

PRINTED IN U.S.A.

Version 1.0  
Code No.:769-03313

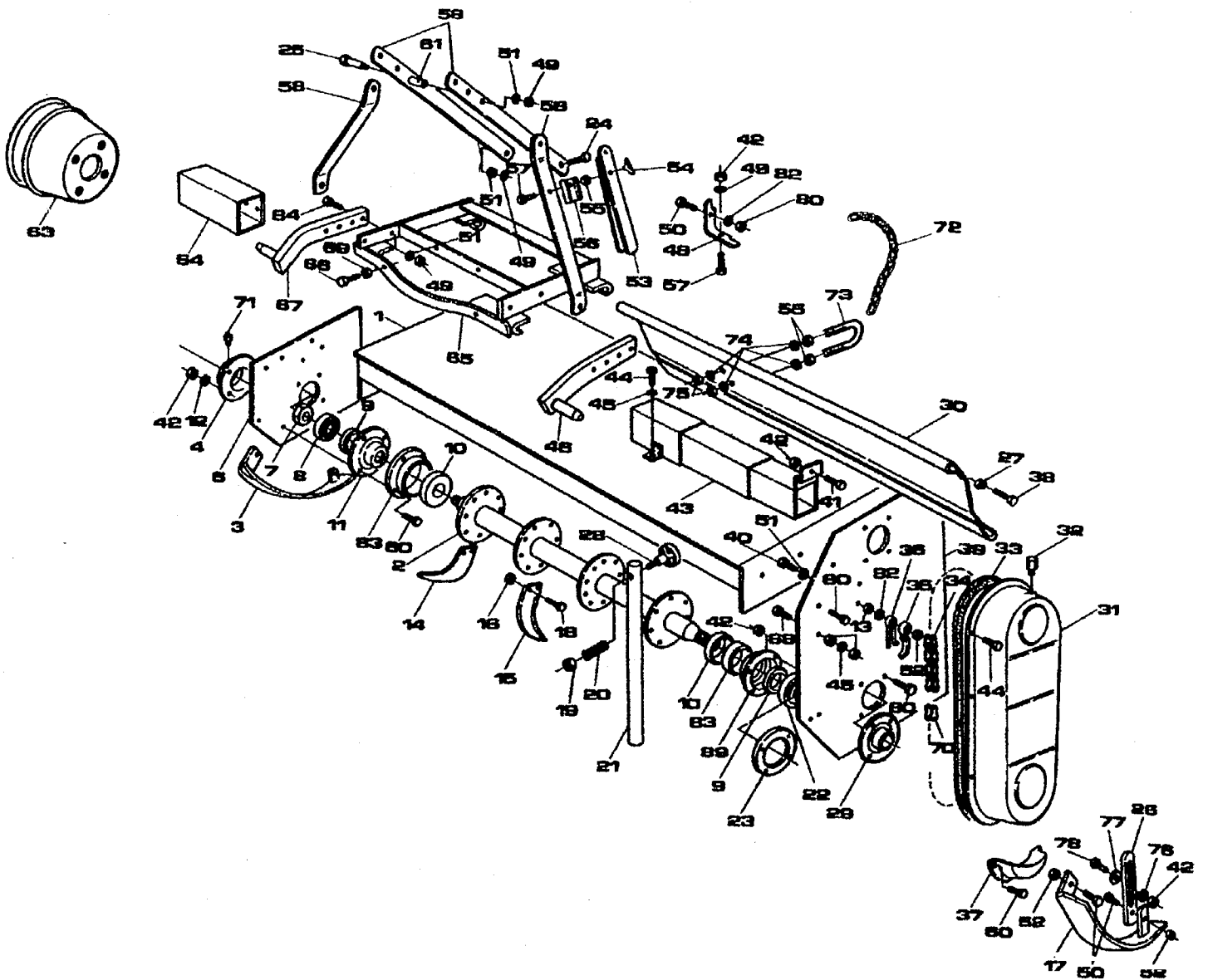

Ref.	Part #	Part Description	Qty.
1	022-2002	Main Frame (42" Tiller)	1
	052-2002	Main Frame (66" Tiller)	1
2	023-4081	Rotor (42" Tiller)	1
	053-4081	Rotor (66" Tiller)	1
3	012-2051	Skid - Right	1
4	003-0091	Bearing Cover - Right	1
6	002-2011	Right Side Panel	1
7	003-0095	Safety Nut	1
8	003-0094	Bearing 6306	1
9	003-4098	Oil Seal 40.60.10 (42" Tiller)	2
	005-7567	Oil Seal 40.56.8 (66" Tiller)	2
10	002-2074	Dirt Shield	2
11	003-0092	Bearing Cover Inner	2
12	000-1011	Lock Washer M10	11
13	000-1010	Nut M10	15
14	003-0104D	C-Knife Right	-
15	003-0104S	C-Knife Left	-
16	002-1105	Nut M12	-
17	022-2051	Skid - Left	1
18	002-1104	Bolt M12 x 30	-
19	003-0358	Nut M14	1
20	000-1176	Jack Stand Spring	1
21	003-4324	Jack Stand	1
22	000-1061	Bearing 6307	1
23	003-4121	Disk with Holes	1
24	001-5122	Bolt M12 x 90	1
25	003-4286	Bolt M12 x 100	1
26	002-1051	Serrated Adj. Arm	2
27	000-3124	Nut m16	2
28	002-6187	Bolt M114 x 70	1
29	003-4122	BearingCover Left	1
30	023-0303	Tailgate (42" Tiller)	1
	053-0303	Tailgate (66" Tiller)	1
31	001 1030	Chain Case Cover	1
32	001 0035	Breather Cap	1

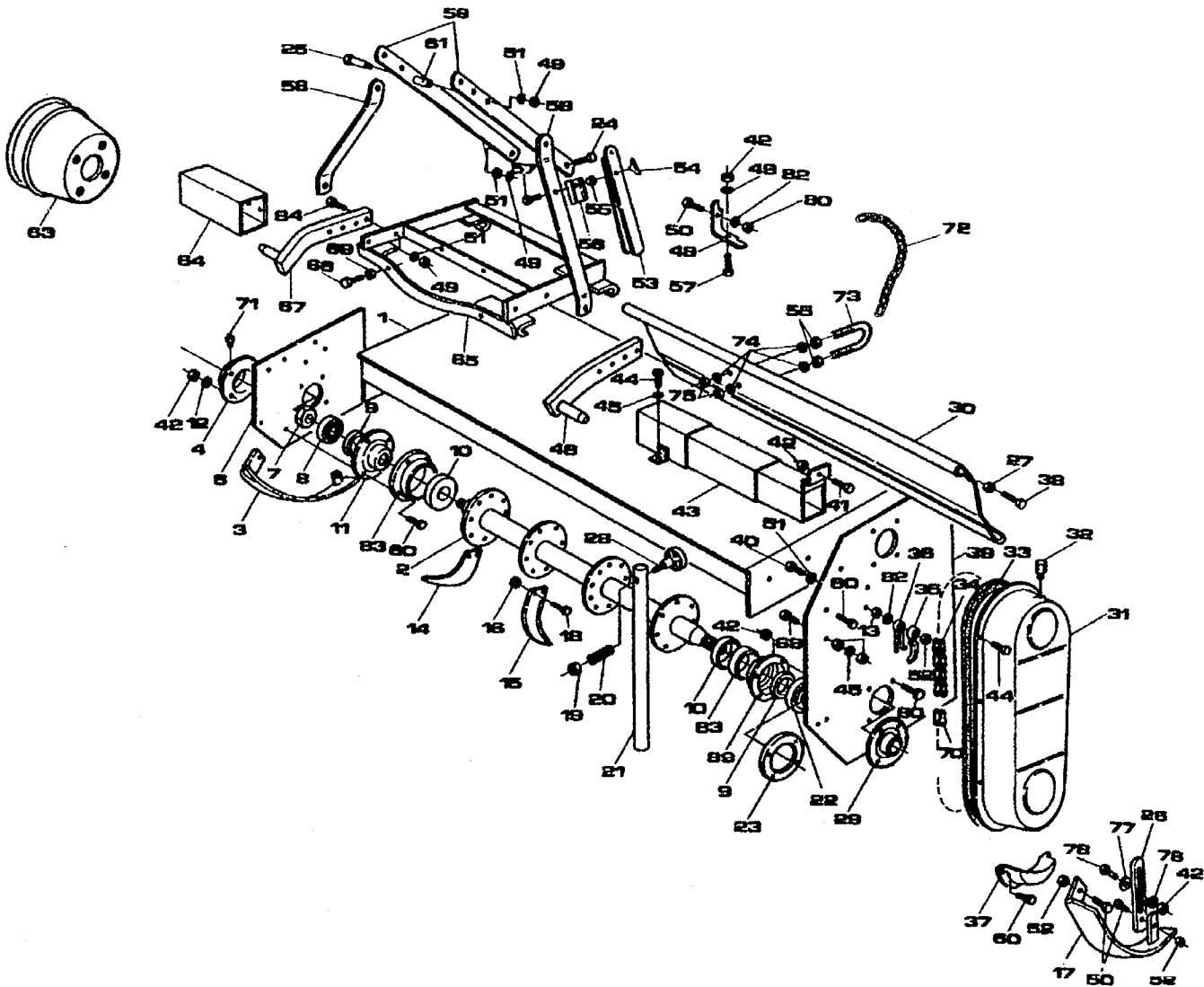

Ref.	Part #	Part Description	Qty.
33	002-2032	Gasket	1
34	003-4141	Chain ASA 80 x 36	1
35	003-0148	Chain Tensioner	1
36	003-0158	Chain Tensioner Spring	1
37	002-2035	Chain Pan Protection	1
38	003 0309	Bolt M16 x 70	2
39	002-2021	Left Side Panel	1
40	003-0155	Bolt M10 x 60	1
41	000-1101	Bolt M10 x 45	1
42	000-1279	Nut M10	2
43	012-1253	Telescopic Cover (42" Tiller)	1
	032-1253	Telescopic Cover (66" Tiller)	1
44	000-6349	Bolt M10 x 20	2
45	000-2034	Lock Washer M10	2
46	023-4261	Lower Hitch Plate Left	1
47	003-0334	Bolt M10 x 55	1
48	003-0321	Chain Hitch	1
49	000-3038	Nut M12	10
50	000-1278	Bolt M10 x 30	5
51	000-1077	Lock Washer M12	-
52	003-0156	Nut M10	4
53	001-0335	Ratchet Arm	11
54	000-1807	Wing Nut M8	1
55	000-1806	Nut M8	1
56	003-0339	Locking Cover	1
57	003-0334	Bolt M10 x 55	11
58	003-4273	Top Hitch Support	2
59	003-4272	Top Hitch Arm	2
60	003-3176	Bolt M10 x 25	
61	002-1285	Spacer	1
63	000-8663	Protective Cover	11
64	013-0260	Right Protection (42" Tiller)	1
	043-0260	Right Protection (66" Tiller)	1
65	002-2251	Side Shift Complete (42" Tiller)	1
	012-2251	Side Shift Complete (66" Tiller)	1
66	002-2279	Bolt M12 x 60	-
67	013-4261	Lower Hitch Plate Right	1

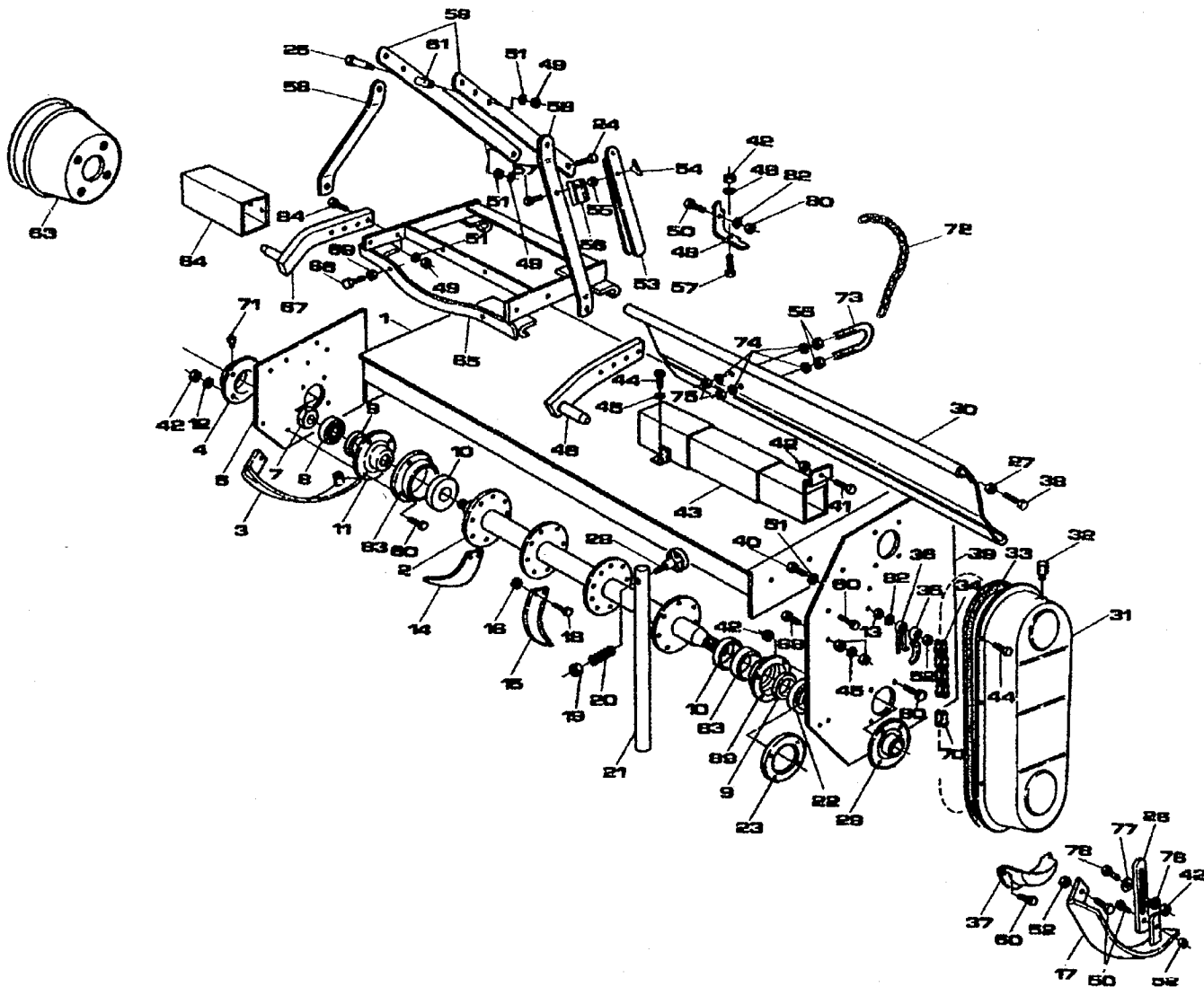

Ref.	Part #	Part Description	Qty.
68	003-0331	Bolt M10 x 50	11
69	000-1106	Nut M12	2
70	003-4151	Chain Link Inner	1
	009-1206	False Chain Link	1
0	000-1065	Grease Fitting	11
72	001-0318	Chain	1
73	001 1327	U bolt	1
74	001 5230	Flat Washer 8mm	4
75	001 1328	Nut m8	2
76	002-1053	Washer with Hole	2
77	002-1052	Washer with Thread	2
78	003-0331	Bolt M10 x 50	1
	003-0155	Bolt M10 x 60	1
80	001 4106	Nut 10mm	2
82	003-0157	Washer	1
83	001-0073	Ext. Cover (42" Tiller)	2
	008-4083	Ext. cover (66" Tiller)	2
84	002-1257	Bolt M12 x 60	2
	003-0054	Bolt M12 x 50	2

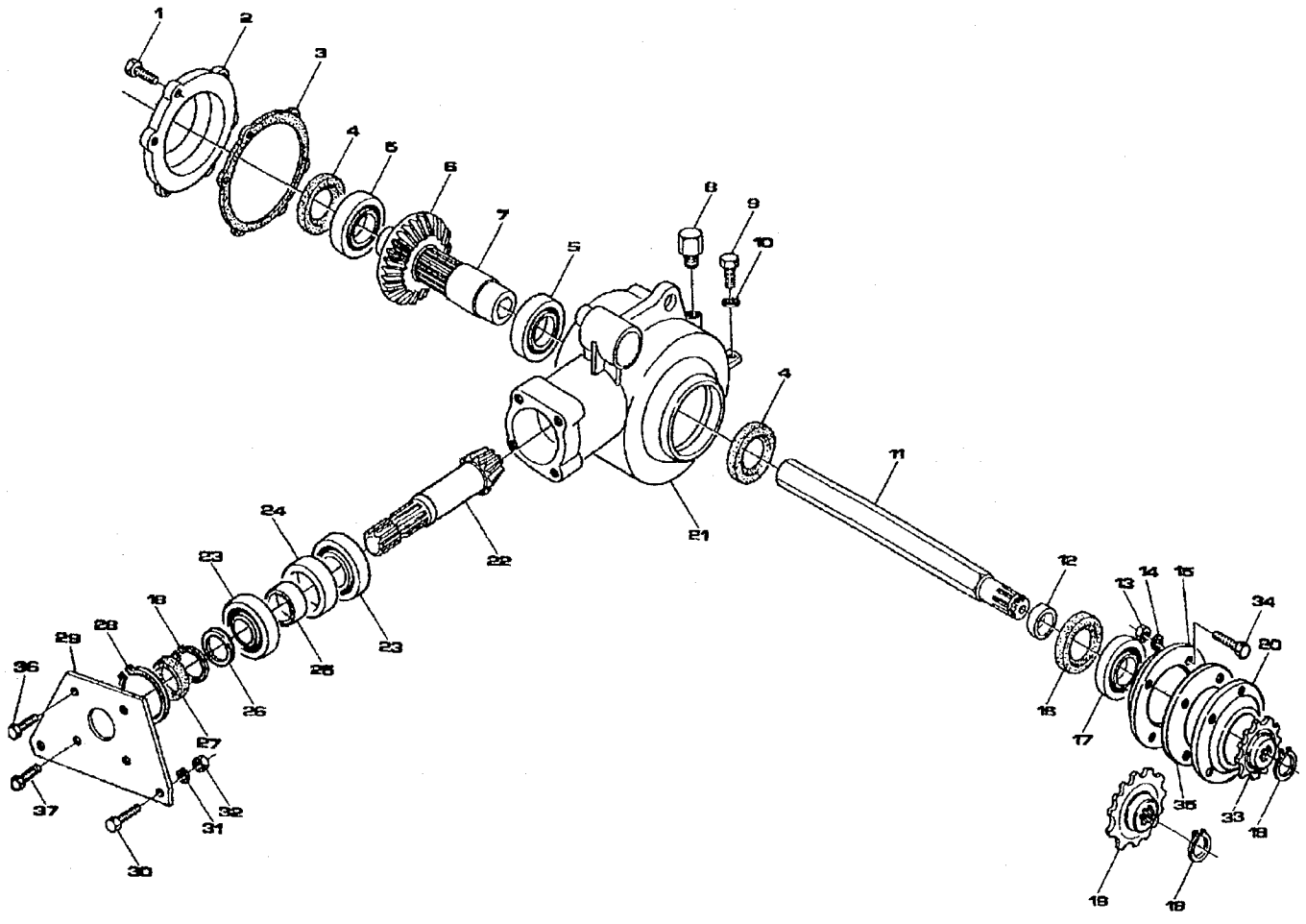



Ref.	Part #	Part Description	Qty.
1	000-1046	Bolt 10 x 20	7
2	002-2178	Gear Cover	1
3	002-2180	Gasket	1
4	000-2133	Oil Seal 50.68.10	2
5	003-4178	Bearing 6010	2
6	002-1176	Bevel Gear	1
7	003-4175	Shaft Coupling	1
8	000-1107	Breather Cap	1
9	002 3265	Bolt M12 x 40	1
10	000-2038	Lock Washer M12	1
11	023-4166	Hexagonal Shaft (42")	1
	053 4166	Hexagonal Shaft (66")	1
12	000-2049	Spacer	1
13	000-1279	Nut M10	6
14	000-1280	Lock Washer M10	6
15	003-0092	Bearing Cover Inner	1
16	003-4159	Oil Seal 45.60.10	1
17	000-1061	Bearing 6307	1
18	004-2122	Snap Ring M35 Ext.	1
19	003-4131	Sprocket Z14 Standard	1
20	003-4122	Bearing Cover Outer	1
21	002-2170	Gear Box Housing Cast	1
22	002-1177	Pinion Gear	1
23	002-5332	Bearing 6207	1
24	003-4197	Spacer-Rear Outer	2
25	003-4198	Spacer-Rear Inner	1
26	003-4196	Spacer-Ring	1
27	503-199B	Oil Seal 35.72.10	1
28	002-5329	Snap Ring 72 inner	1
29	003-0218	Metal Cover	1
30	000-7255	Bolt M12 x 35	2
31	000-1077	Lock Washer 12mm	2
32	000-3038	Nut mm12	2
33	003-4134	Sprocket Z11	1
34	000-1278	Bolt M10 x 30	-
35	003-4121	Disk with Holes	-
36	000-1009	Bolt m10 x 35	2
37	000-1008	Bolt m10 x 30	2
	050-0606	Gear Box Complete	1

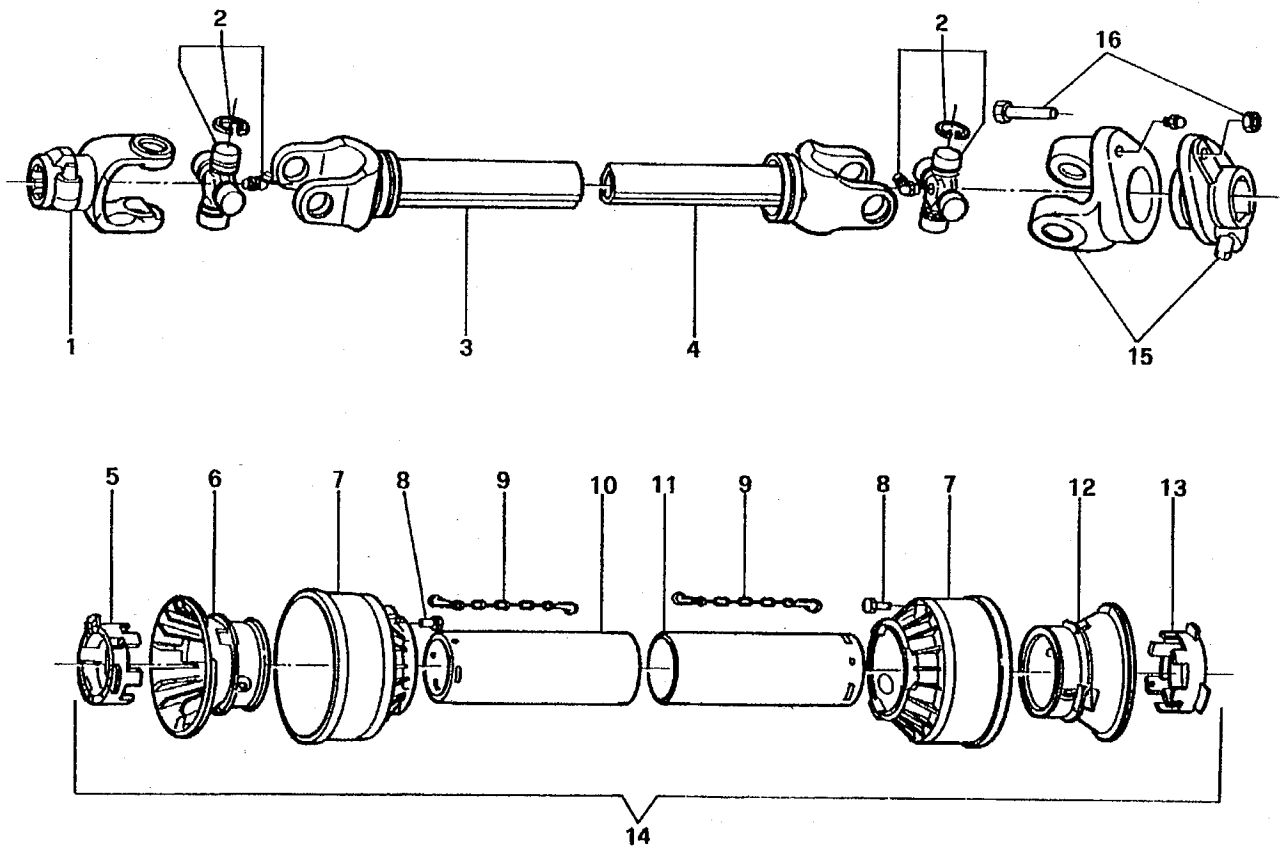

Ref.	Part #	Part Description	Qty.
1	023-001E	Yoke 1 3/8"	1
2	013-130E	Cross and Bearing	2
3	1943045C	Outer Tube and Yoke	1
4	1953047C	Inner Tube and Yoke	1
5	1784210C	Tube Bearing Outer	1
6	1784201C	Outer Tube Rigid Cone	1
7	1784203C	Soft Cone	1
8	1784212C	Pin for Stop Rotation	2
9	016-025E	Chain	2
10	1773043c	Outer Shield	1
11	1872043C	Inner Shield	1
12	1784202C	Inner Tube Rigid Cone	1
13	1784211C	Tube Bearing Inner	1
14	9403443C	Shield Complete	1
15	1483037C	Yoke Shearbolt	1
16	000-505E	Shearbolt and Nut	1
	050-0407	Driveline Complete	1

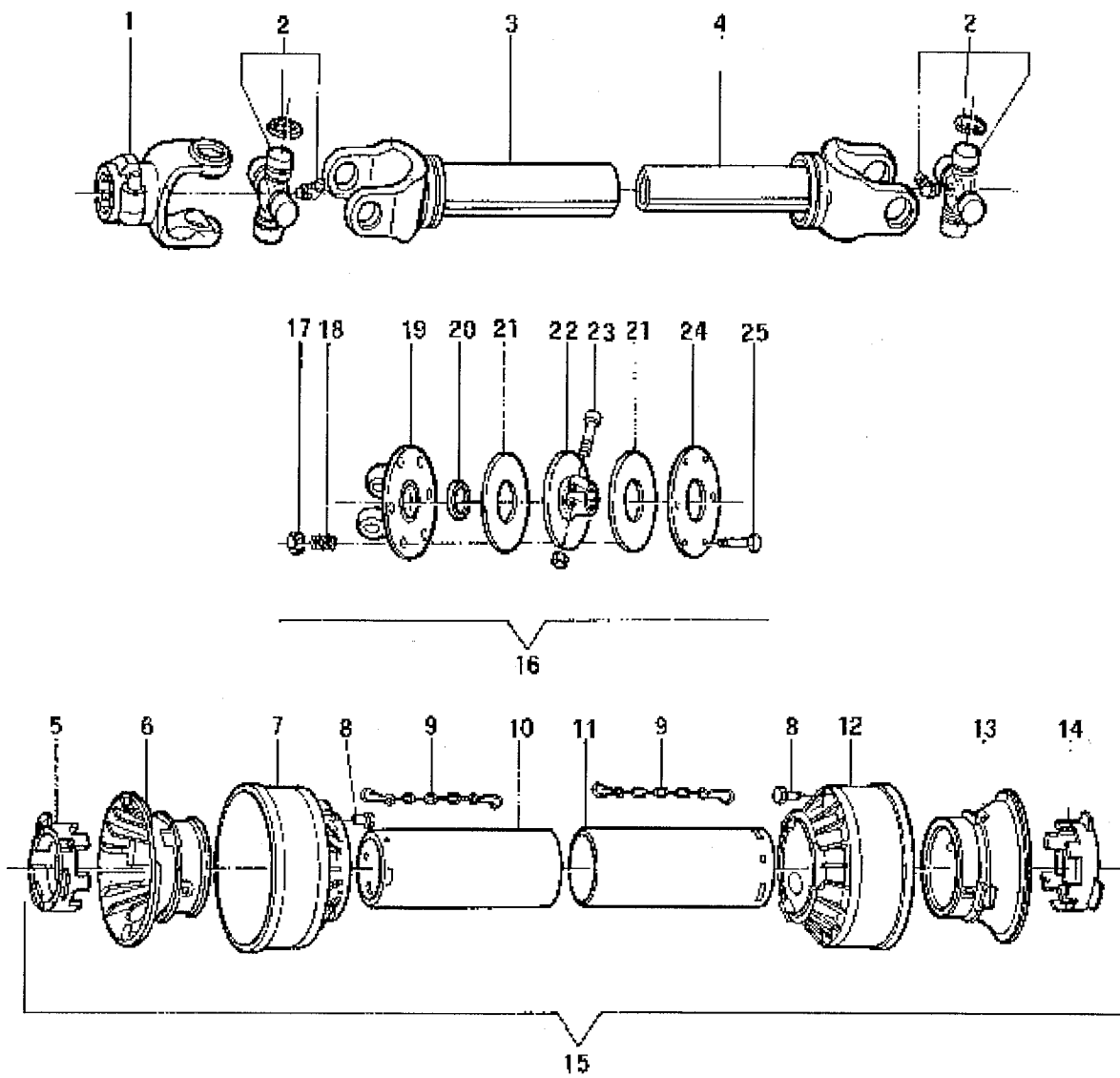

Ref.	Part #	Part Description	Qty.
1	023 001E	Yoke 1 3/8 6	1
2	013 130E	Cross, Bearing	2
3	1943045C	Outer Tube & Yoke	1
4	1953047C	Inner Tube & Yoke	1
5	230 001E	Yoke Shearbolt	1
6	178 4210C	Tube Bearing Outer	1
7	178 4201C	Outer Tube Rigid Cone	1
8	178 4203C	Soft Cone	1
9	178 4212C	Pin For Stop Rotation	2
10	177 3043C	Outer Shield	1
11	016 025E	Chain	2
12	187 2043C	Inner Shield	1
13	178 4202C	Inner Tube Rigid Cone	1
14	178 4211C	Tube Bearing Inner	1
15	940 3443C	Shield Complete	1
16	231 001E	Slip Clutch Yoke Complete	1
17	000 501E	Bolt M10x80	8
18	014 021E	Dirt Shield	1
19	001 5237	Nut 10MM nylock	8
20	014 022E	Spring	8
21	013 014E	Yoke Slip Clutch	1
22	014 019E	Friction Disk	2
23	015 020E	Spacer	1
24	014 018E	Body Friction Clutch	1
25	000 502E	Bolt M12x65 With Nut	1
26	014 020E	Outer Flange	1
	050 0408	PTO Complete Slip Clutch	-









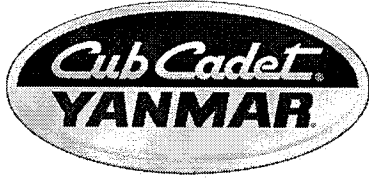

***Rotary Tiller 42" & 66"***

---

***RT42 & RT66***

Cub Cadet Yanmar LLC.  
P.O. Box 368023  
Cleveland, OH 44136