



# MODEL: AHP COUNTER MODEL ACHIEVER HOTPLATE

**WOLF RANGE COMPANY**



**Model AHP424**

**BASIC MODELS:**

<b>AHP212</b> 12" wide	<b>AHP424</b> 24" wide
<b>AHP636</b> 36" wide	<b>AHP848</b> 48" wide

**KEY FEATURES:**

- Stainless steel sides and control panel
- Full width pull out crumb tray
- Heavy duty cast iron top grates
- 30,000 BTU/hr open burners with lift-off heads
- Standing pilot ignition system
- One infinite heat control valve for each burner
- 4" adjustable legs
- 3/4" rear gas connection and gas pressure regulator
- One year limited parts and labor warranty

**OPTIONAL FEATURES:**

- Step-up burners. Rear burners elevated 4".
- Half hot-top on rear burner, 15,000 BTU/hr input.
- 5-5/8", 8", 10", and 11" legs
- Stainless steel stand with undershelf and casters

**EXTERIOR DIMENSIONS:**

\_\_\_\_\_ " W x 33" D x 12-3/8" working height on 6" adjustable legs

**CLEARANCES:**

	Combustible	Non-Combustible
Rear	6"	0"
Sides	6"	0"



CSA design certified. NSF listed.

Approved by \_\_\_\_\_

Date: \_\_\_\_\_

**SPECIFY TYPE OF GAS WHEN ORDERING.  
SPECIFY ALTITUDE WHEN ABOVE 2,000 FT.**

## **WOLF RANGE COMPANY**

Wolf Range Company  
Division of ITW Food Equipment Group LLC  
(800) 366-9653  
www.wolfrange.com

**MODEL: AHP Counter Model Achiever HotPlate**



# MODEL: AHP COUNTER MODEL ACHIEVER HOTPLATE

### INSTALLATION REQUIREMENTS:

1. A gas pressure regulator sized for this unit is included. Natural Gas 5.0" W.C. Propane Gas 10.0" W.C.
2. An adequate ventilation system is required for commercial cooking equipment. Information may be obtained by writing to the National Fire Protection Association, 1 Batterymarch Park, Quincy, MA 02169, www.NFPA.org. When writing refer to NFPA No. 96.
3. These units are manufactured for installation in accordance with National Fuel Gas Code, ANSI-Z223.1/NFPA #54 (latest edition). Copies may be obtained from The American

Gas Association, Accredited Standards Committee Z223 @ 400N. Capital St. NW, Washington, DC 20001, or the Secretary Standards Council, NFPA, 1 Batterymarch Park, Quincy, MA 02169-7471.

### NOTE: In the Commonwealth of Massachusetts

All gas appliances vented through a ventilation hood or exhaust system equipped with a damper or with a power means of exhaust shall comply with 248 CMR.

4. This appliance must be installed with a 6" clearance at both sides and the rear adjacent to combustible construction.

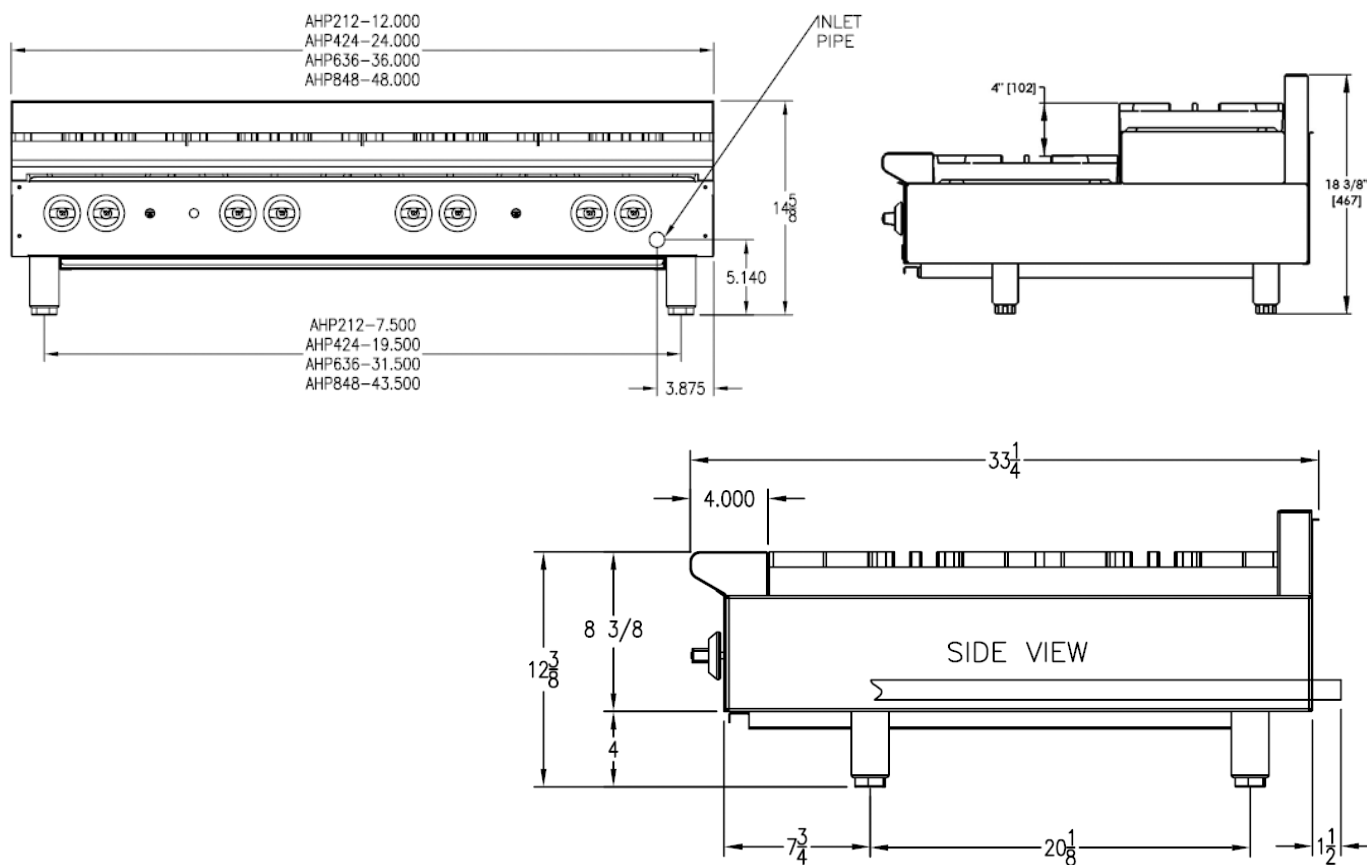

MODEL	WIDTH	DEPTH	OVERALL HEIGHT	WORKING HEIGHT	NO. OF BURNERS	TOTAL BTU/HR.	APPROX. SHIP WT. (LB/KG)
AHP212	12"	33"	14-5/8"	12-3/8"	2	60,000	95 lbs./43 kg
AHP424	24"				4	120,000	165 lbs./74 kg
AHP636	36"				6	180,000	265 lbs./119 kg
AHP848	48"				8	240,000	310 lbs./140 kg

**NOTE: In line with its policy to continually improve its product, Wolf Range Company reserves the right to change materials and specifications without notice.**

***This appliance is manufactured for commercial use only and is not intended for home use.***