

### Contents

Page

#### IMPORTANT!

**Please Read Before Starting** ..... 2

**1. GENERAL** ..... 3

- 1-1. Tools Required for Installation (not supplied)
- 1-2. Accessories Supplied with Unit
- 1-3. Optional Copper Tubing Kit
- 1-4. Type of Copper Tube and Insulation Material
- 1-5. Field Wiring
- 1-6. Additional Materials Required for Installation

**2. INSTALLATION SITE SELECTION** ..... 4

- 2-1. Indoor Unit
- 2-2. Outdoor Unit

**3. HOW TO INSTALL THE INDOOR UNIT** ..... 6

- 3-1. Remove the Rear Panel from the Unit
- 3-2. Make a Hole
- 3-3. Install the Rear Panel on the Wall
- 3-4. Remove the Grille to Install the Indoor Unit
- 3-5. Shape the Indoor Side Tubing
- 3-6. Wiring Instructions
- 3-7. Recommended Wire Length and Diameter
- 3-8. Wiring Instructions for Inter-unit Connections
- 3-9. Mounting
- 3-10. Drain Hose

**4. HOW TO INSTALL THE OUTDOOR UNIT** ..... 15

- 4-1. Wiring Instructions for the Outdoor Unit

**5. REFRIGERANT TUBING** ..... 16

- 5-1. Use of the Flaring Method
- 5-2. Flaring Procedure with a Flare Tool
- 5-3. Caution before Connecting Tubes Tightly
- 5-4. Connecting Tubing between Indoor and Outdoor Units
- 5-5. Insulation of Refrigerant Tubing
- 5-6. Taping the Tubes

### Model Combinations

Combine indoor and outdoor units only as listed below.

<u>Indoor Units</u>	<u>Outdoor Units</u>
---------------------	----------------------

KHS0951	_____	CH0951
---------	-------	--------

KHS1251	_____	CH1251
---------	-------	--------

Power Source:  
60 Hz, single-phase, 115 V

---

KHS1852	_____	CH1852
---------	-------	--------

Power Source:  
60 Hz, single-phase, 230/208 V

**5-7. Finishing the Installation**

**6. AIR PURGING** ..... 18

- Air Purging with a Vacuum Pump (for Test Run)
- Basic Function of the Service Valves
- Pump Down

**7. REMOTE CONTROL UNIT INSTALLATION POSITION** ..... 22

- 7-1. Mounting on a Wall



#### IMPORTANT

Power source for CH0951 and CH1251 is 60 Hz, single-phase **115 V**.

**SANYO FISHER COMPANY**

A DIVISION OF SANYO NORTH AMERICA CORPORATION  
21605 Plummer Street  
Chatsworth, CA 91311 U.S.A.

In Canada

**SANYO Canada Inc.**

300 Applewood Crescent, Concord  
Ontario, L4K 5C7, Canada

# IMPORTANT!

## Please Read Before Starting

This air conditioning system meets strict safety and operating standards. As the installer or service person, it is an important part of your job to install or service the system so it operates safely and efficiently.

**For safe installation and trouble-free operation, you must:**

- Carefully read this instruction booklet before beginning.
- Follow each installation or repair step exactly as shown.
- Observe all local, state, and national electrical codes.
- Pay close attention to all warning and caution notices given in this manual.



**WARNING**

This symbol refers to a hazard or unsafe practice which can result in severe personal injury or death.



**CAUTION**

This symbol refers to a hazard or unsafe practice which can result in personal injury or product or property damage.

### If Necessary, Get Help

These instructions are all you need for most installation sites and maintenance conditions. If you require help for a special problem, contact our sales/service outlet or your certified dealer for additional instructions.

### In Case of Improper Installation

The manufacturer shall in no way be responsible for improper installation or maintenance service, including failure to follow the instructions in this document.

---

## SPECIAL PRECAUTIONS

---

**WARNING**

### When Wiring



**ELECTRICAL SHOCK CAN CAUSE SEVERE PERSONAL INJURY OR DEATH. ONLY A QUALIFIED, EXPERIENCED ELECTRICIAN SHOULD ATTEMPT TO WIRE THIS SYSTEM.**

- Do not supply power to the unit until all wiring and tubing are completed or reconnected and checked.
- Highly dangerous electrical voltages are used in this system. Carefully refer to the wiring diagram and these instructions when wiring. Improper connections and inadequate grounding can cause **accidental injury or death**.
- **Ground the unit** following local electrical codes.
- Connect all wiring tightly. Loose wiring may cause overheating at connection points and a possible fire hazard.

### When Transporting

---

Be careful when picking up and moving the indoor and outdoor units. Get a partner to help, and bend your knees when lifting to reduce strain on your back. Sharp edges or thin aluminum fins on the air conditioner can cut your fingers.

### When Installing...

---

#### ...In a Ceiling or Wall

Make sure the ceiling/wall is strong enough to hold the unit's weight. It may be necessary to construct a strong wood or metal frame to provide added support.

#### ...In a Room

Properly insulate any tubing run inside a room to prevent "sweating" that can cause dripping and water damage to walls and floors.

#### ...In Moist or Uneven Locations

Use a raised concrete pad or concrete blocks to provide a solid, level foundation for the outdoor unit. This prevents water damage and abnormal vibration.

#### ...In an Area with High Winds

Securely anchor the outdoor unit down with bolts and a metal frame. Provide a suitable air baffle.

#### ...In a Snowy Area (for Heat Pump-type Systems)

Install the outdoor unit on a raised platform that is higher than drifting snow. Provide snow vents.

### When Connecting Refrigerant Tubing

---

- Use the flare method for connecting tubing.
- Apply refrigerant lubricant to the matching surfaces of the flare and union tubes before connecting them, then tighten the nut with a torque wrench for a leak-free connection.
- Check carefully for leaks before starting the test run.

### When Servicing

---

- Turn the power OFF at the main power box (mains) before opening the unit to check or repair electrical parts and wiring.
- Keep your fingers and clothing away from any moving parts.
- Clean up the site after you finish, remembering to check that no metal scraps or bits of wiring have been left inside the unit being serviced.

# 1. General

This booklet briefly outlines where and how to install the air conditioning system. Please read over the entire set of instructions for the indoor and outdoor units and make sure all accessory parts listed are with the system before beginning.





## 1-1. Tools Required for Installation (not supplied)

1. Standard screwdriver
2. Phillips head screwdriver
3. Knife or wire stripper
4. Tape measure

5. Carpenter's level
6. Sabre saw or key hole saw
7. Hacksaw
8. Core bits
9. Hammer
10. Drill
11. Tube cutter
12. Tube flaring tool
13. Torque wrench
14. Adjustable wrench
15. Reamer (for deburring)

## 1-2. Accessories Supplied with Unit

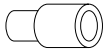
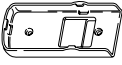
Table 1

Parts	Figure	Q'ty	Parts	Figure	Q'ty	Parts	Figure	Q'ty
Rawl plug		12	Tapping screw	Truss-head Phillips 5/32 x 5/8" (4 x 16 mm) 	12	Remote control unit		1
Drain hose adapter		1	Remote control holder		1	AAA alkaline battery		2
Hex wrench*		1	* Packed in the outdoor unit.					

## 1-3. Optional Copper Tubing Kit

Copper tubing for connecting the outdoor unit to the indoor unit is available in kits which contain the narrow and wide tubing, fittings and insulation. Consult your nearest sales outlet or A/C workshop.

## 1-4. Type of Copper Tube and Insulation Material

If you wish to purchase these materials separately from a local source, you will need:

1. Deoxidized annealed copper tube for refrigerant tubing as detailed in Table 2.  
When cutting tubing, add approximately 12" to 16" (30 cm to 40 cm) to each tube length to reduce vibration between the air conditioning units.

2. Foamed polyethylene insulation for the specified O.D. copper tubes as required to precise length of tubing. Wall thickness of the insulation should be not less than 0.3 in. (8 mm).

## 1-5. Field Wiring

Use insulated copper wire for field wiring. Wire size varies with the total length of wiring. Refer to 3-6. Wiring Instructions for details.



**CAUTION**

**Check local electrical codes and regulations before obtaining wire. Also, check any specified instructions or limitations.**

Table 2

Narrow Tube		Wide Tube		Model
Outer Dia.	Thickness	Outer Dia.	Thickness	
6.35 mm (1/4")	0.8 mm (0.0314")	9.52 mm (3/8")	0.8 mm (0.0314")	CH0951
6.35 mm (1/4")	0.8 mm (0.0314")	12.7 mm (1/2")	0.8 mm (0.0314")	CH1251
6.35 mm (1/4")	0.8 mm (0.0314")	15.88 mm (5/8")	1.0 mm (0.0394")	CH1852

## 1-6. Additional Materials Required for Installation

1. Refrigeration (armored) tape
2. Insulated staples or clamps for connecting wire  
(See local codes)
3. Putty
4. Refrigeration lubricant
5. Clamps or saddles to secure refrigerant tubing

## 2. Installation Site Selection

### 2-1. Indoor Unit



#### WARNING

To prevent abnormal heat generation and the possibility of fire, do not place obstacles, enclosures and grilles in front of or surrounding the air conditioner in a way that may block air flow.

#### AVOID:

- direct sunlight.
- nearby heat sources that may affect performance of the unit.
- areas where leakage of flammable gas may be expected.
- places where large amount of oil mist exist.

#### DO:

- select an appropriate position from which every corner of the room can be uniformly cooled. (High on a wall is best.)
- select a location that will hold the weight of the unit.
- select a location where tubing and drain hose have the shortest run to the outside. (Fig. 1)
- allow room for operation and maintenance as well as unrestricted air flow around the unit. (Fig. 2)
- install the unit within the maximum elevation difference (H) above the outdoor unit and within a total tubing length (L) from the outdoor unit as detailed in Table 3 and Fig. 3a.

Table 3

Max. Allowable Tubing Length at Shipment (ft.)	Limit of Tubing Length (L) (ft.)	Limit of Elevation Difference (H) (ft.)	Required Amount of Additional Refrigerant (oz./ft.)*	Model
25	50	23	a) 0.16	9,000 BTU
25	65	23	b) 0.27	12,000/18,000 BTU

\* If total tubing length becomes a) 25 to 50 ft. (max.), b) 25 to 65 ft. (max.) charge additional refrigerant (R22) by a) 0.16 oz./ft., b) 0.27 oz./ft. No additional compressor oil is necessary.

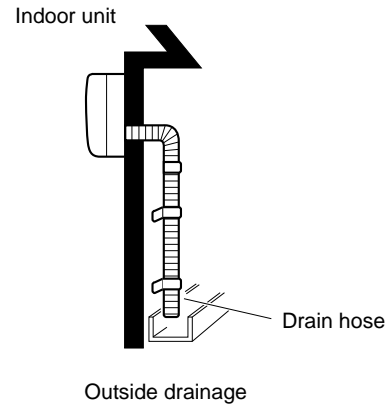

Fig. 1

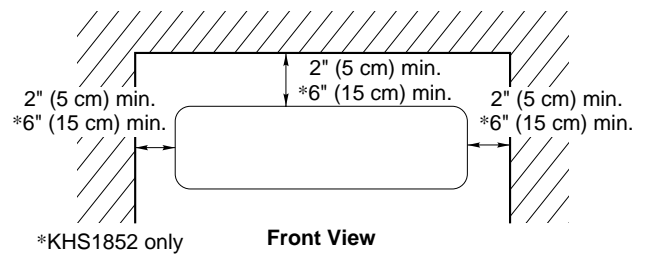

Fig. 2

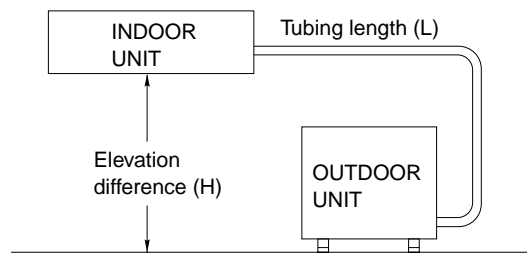

Fig. 3a



#### CAUTION

For stable operation of the air conditioner, do not install wall-mounted type indoor units under 5 ft. (1.5 m) from floor level.

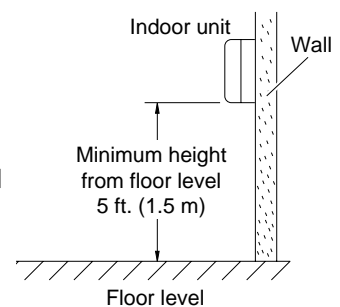

Fig. 3b

## 2-2. Outdoor Unit

### AVOID:

- heat sources, exhaust fans, etc. (Fig. 4)
- damp, humid or uneven locations.

### DO:

- choose a place as cool as possible.
- choose a place that is well ventilated.
- allow enough room around the unit for air intake/exhaust and possible maintenance. (Fig. 5a)

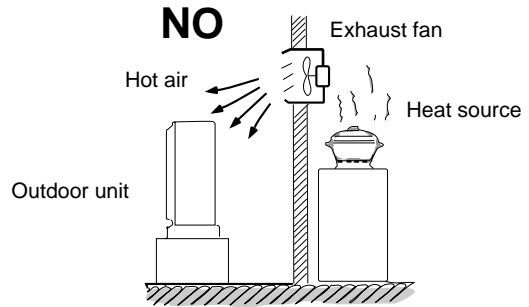

Fig. 4



### CAUTION

- Install the outdoor unit above snowfall line.
- Do not place objects on or sit on the outdoor unit. Also, never block the air intake/outlet or exhaust. Distortion of the outdoor unit or incomplete combustion may result.
- Do not introduce foreign matter into the air intake/outlet or exhaust. Do not poke them with such objects as a stick.

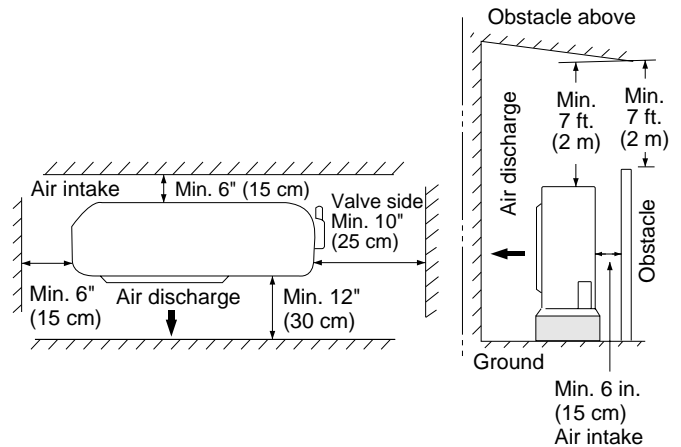

Fig. 5a

- provide a solid base (level concrete pad, concrete block, 2 to 2-1/2 (CH09, 12) / 2-1/2 to 3 (CH18) in. × 16 in. (5 to 6.5 / 6.5 to 7.5 × 40 cm) beams or equal), a minimum of 4 in. (10 cm) above ground level to reduce humidity and protect the unit against possible water damage and decreased service life (Figs. 5b and 5c).

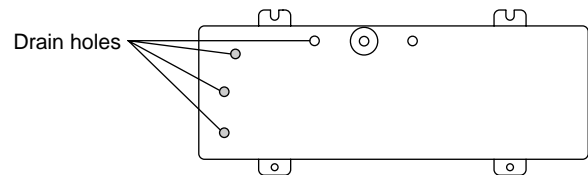

Fig. 5b



### CAUTION

A solid base must not cover the hole of the bottom plate.

- use lug bolts or equal to bolt down unit, reducing vibration and noise.

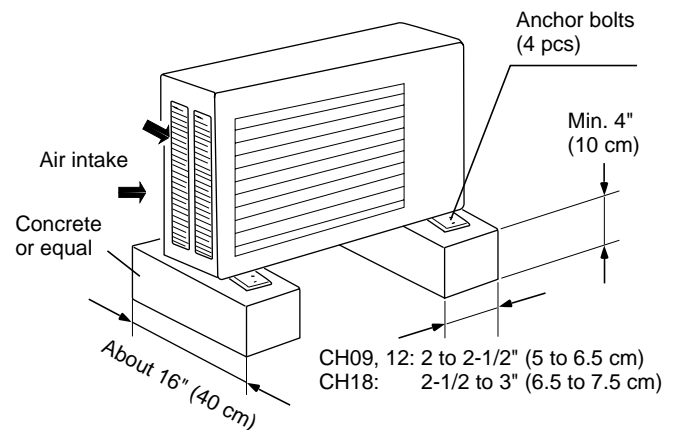

Fig. 5c

### 3. How to Install the Indoor Unit

#### 3-1. Remove the Rear Panel from the Unit

- (1) Remove and discard the set screw on the rear panel. (Fig. 6)
- (2) Press the 2  $\triangle$  marks on the frame cover and disengage the stationary tabs from the frame. (Fig. 7)
- (3) Remove the rear panel.

**NOTE**

Tubing can be extended in 5 directions (KHS0951, KHS1251 and KHS1852) as shown in Fig. 8a or 8b. Select the direction you need providing the shortest run to the outside unit.

#### 3-2. Make a Hole

- (1) Place the rear panel from the indoor unit on the wall at the location selected. Make sure the panel is horizontal, using a carpenter's level or tape measure to measure down from the ceiling. Wait until after cutting the hole before attaching the rear panel to the wall.
- (2) Determine which side of the unit you should make the hole for tubing and wiring. (Fig. 9)
- (3) Before making the hole, check carefully that no studs or pipes are directly run behind the spot to be cut.



● Also avoid areas where electrical wiring or conduits are located.

● Switching drain hose and drain cap

- (a) Locate the drain hose and the drain cap. (Fig. 8c)
- (b) Remove the drain hose on the right side by pushing and turning the hose connector counter-clockwise to release it. (Fig. 8c)
- (c) Apply moderate force to pull off the drain cap on the left side. (If you cannot pull it off by hand, use a long-nose pliers.)
- (d) Reattach the drain hose to the left side and the drain cap to the right side. (Fig. 8c)

The above precautions are also applicable if tubing goes through the wall in any other location.

#### In case of right-rear

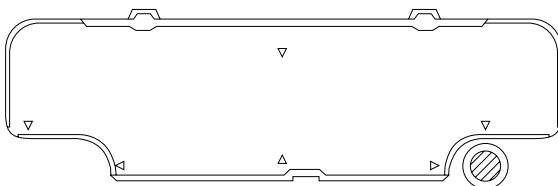
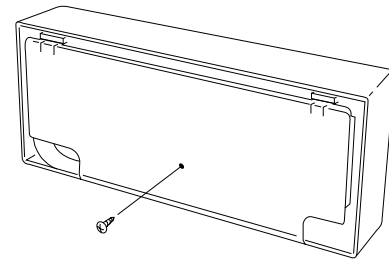

Fig. 9



Set screw only for transportation

Fig. 6

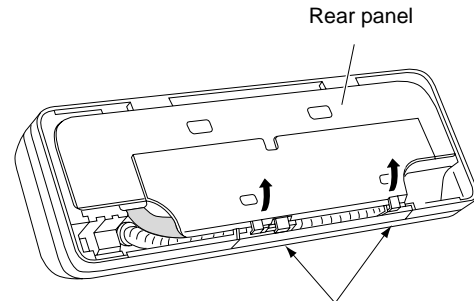

Fig. 7  $\triangle$  marks

#### KHS0951, KHS1251

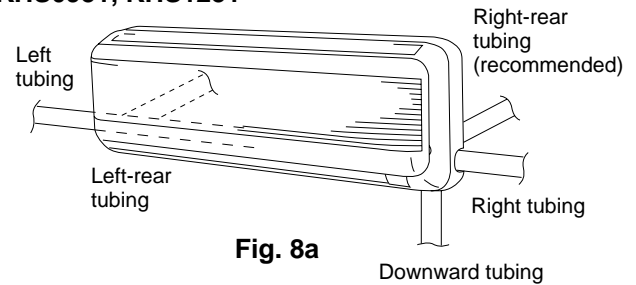

Fig. 8a

#### KHS1852

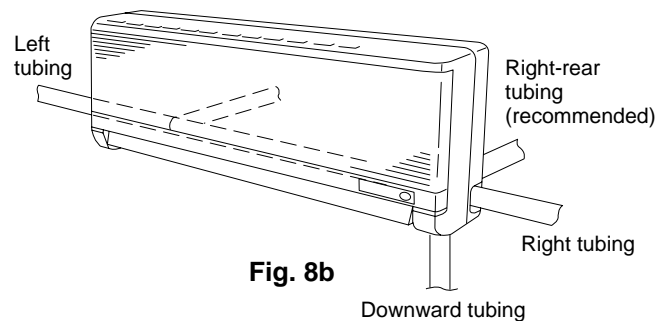

Fig. 8b

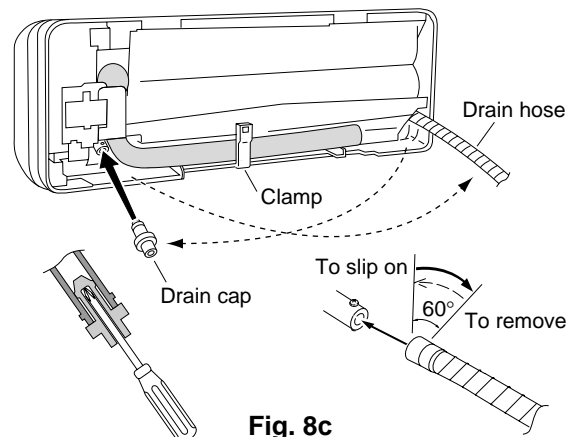

Fig. 8c

- (4) Using a sabre saw, key hole saw or hole-cutting drill attachment, cut a hole in the wall. See Table 4 and Fig. 10.

**Table 4**

Hole Dia.
2-9/16" (65 mm) / 3-5/32" (80 mm)

- (5) Measure the thickness of the wall from the inside edge to the outside edge and cut PVC pipe at a slight angle 0.25 in. (6 mm) shorter than the thickness of the wall. (Fig. 11)
- (6) Place the plastic cover (locally purchased) over the end of the pipe (for indoor side only) and insert the pipe in the wall. (Fig. 12)

**3-3. Install the Rear Panel on the Wall**

Be sure to confirm that the wall is strong enough to suspend the unit.

See either Item a) or b) below depending on the wall type.

**a) If Wooden Wall**

- (1) Attach the rear panel to the wall with the 10 screws provided. (Fig. 13)

If you are not able to line up the holes in the rear panel with the beam locations marked on the wall, use rawl plugs or toggle bolts to go through the holes on the panel or drill 3/16 in. (5 mm) dia. holes in the panel over the stud locations and then mount the rear panel.

- (2) Double check with a ruler or carpenter's level that the panel is level. This is important to install the unit properly. (Fig. 14)
- (3) Make sure the panel is flush against the wall. Any space between the wall and unit will cause noise and vibration.

**b) If Block, Brick, Concrete or Similar Type Wall**

Make 3/16 in. (4.8 mm) dia. holes in the wall. Insert rawl plugs for appropriate mounting screws. (Fig. 15)

**NOTE**

Hole should be made at a slight downward slant to the outdoor side.

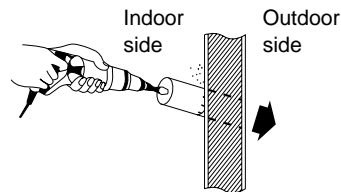

**Fig. 10**

PVC pipe (locally purchased)

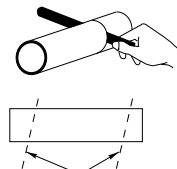

Cut at slight angle

**Fig. 11**

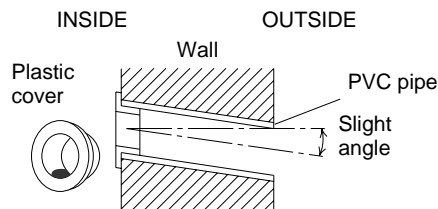

**Fig. 12**

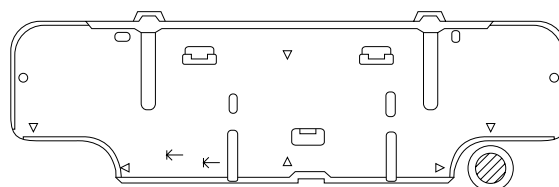

**Fig. 13**

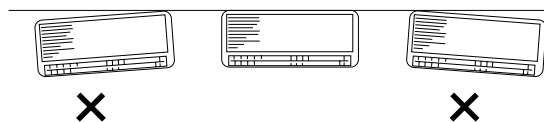

**Fig. 14**

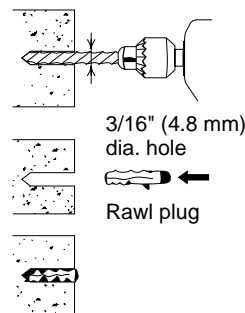

**Fig. 15**

### 3-4. Remove the Grille to Install the Indoor Unit

Basically, these models can be installed and wired without removing the grille. If access to any internal part is needed, follow the steps as given below:

#### How to remove the grille

- (1) Set the flap in the horizontal position.
- (2) Unscrew the screws. (Fig. 16a or 16b)
- (3) Remove the grille. (Fig. 17)
  - (a) Hold both corners of the air intake grille, then pull out and up to open.
  - (b) Pull the lower part of the grille toward you to remove.
  - (c) Use a standard screwdriver to push up the 3 tabs to remove the grille.

#### How to replace the grille

- (1) Close the flaps.
- (2) Reinstall the grille into the lower part while aligning its tabs on the upper part. (Fig. 18) Insert the tabs in the slots and push the lower part of the grille back into position.
- (3) Press at each of the 4 tabs to completely close the grille. Make sure that the grille and frame are firmly fitted together. (Fig. 19)

#### KHS0951, KHS1251

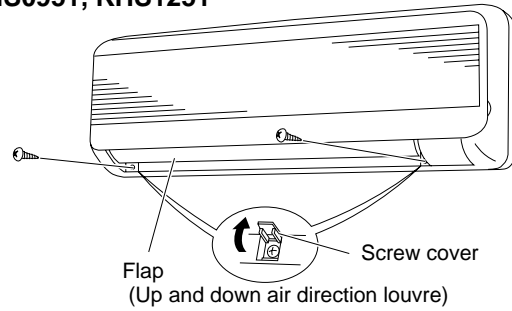

Fig. 16a

#### KHS1852

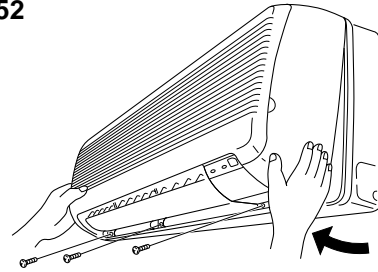

Fig. 16b

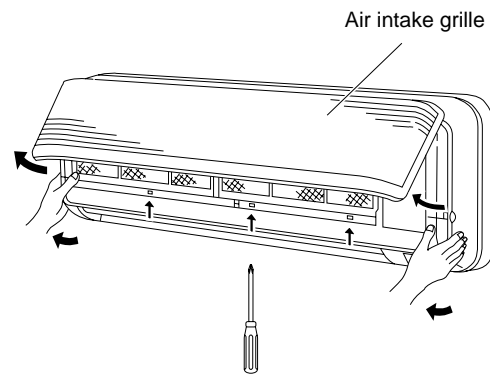

Fig. 17

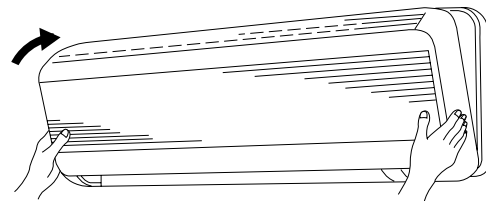

Fig. 18

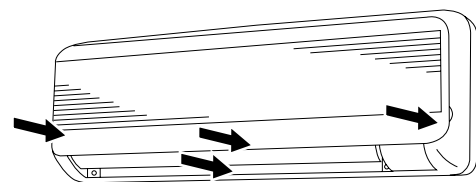

Fig. 19



### 3-5. Shape the Indoor Side Tubing

- 1) Arrangement of tubing by directions
  - a) Right or left tubing

Cut out the corner of the right/left frame with a hacksaw or the like. (Figs. 20 and 21)

- b) Right-rear or left-rear tubing

In this case, the corner of the frame need not be cut.

- 2) To mount the indoor unit on the rear panel:

Hang the 2 mounting slots of the unit on the upper tabs of the rear panel. (Fig. 22)

### 3-6. Wiring Instructions

#### General precautions on wiring

- 1) Before wiring, confirm the rated voltage of the unit as shown on its nameplate, then carry out the wiring closely following the wiring diagram.
- 2) Provide a power outlet to be used exclusively for each unit, with a power supply disconnect and circuit breaker for overcurrent protection provided in the exclusive line.
- 3) To prevent possible hazard due to insulation failure, the unit must be grounded.
- 4) Each wiring connection must be done tightly and in accordance with the wiring system diagram. Wrong wiring may cause the unit to misoperate or become damaged.
- 5) Do not allow wiring to touch the refrigerant tubing, compressor, or any moving parts of the fan.
- 6) Unauthorized changes in the internal wiring can be very dangerous. The manufacturer will accept no responsibility for any damage or misoperation that occurs as a result of such unauthorized changes.

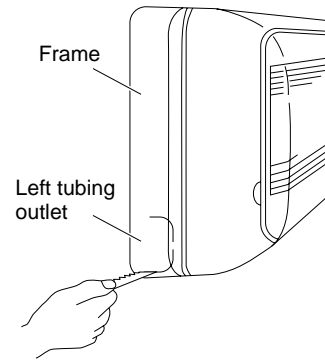

Fig. 20

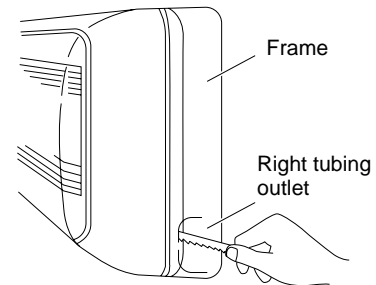

Fig. 21

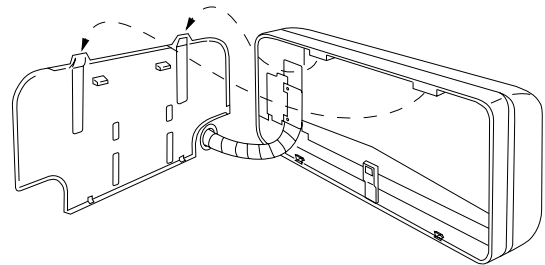

Fig. 22

### 3-7. Recommended Wire Length and Diameter

Regulations on wiring diameter differ from locality to locality. For field wiring requirements, please refer to your local electrical codes. Carefully observe these regulations when carrying out the installation.

**NOTE**

Refer to the wiring system diagram (Fig. 23)

Refer to your local codes or in the absence of local codes with the National Electric Code: ANSI/NFPA70.



**WARNING**

- Be sure to comply with local codes on running the wire from the outdoor unit to the indoor unit (size of wire and wiring method, etc.).
- Each wire must be firmly connected.
- No wire should be allowed to touch refrigerant tubing, the compressor, or any moving part.



**WARNING**

- To avoid the risk of electric shock, each air conditioner unit must be grounded.



**CAUTION**

- Be sure to connect the power supply line to the outdoor unit as shown in the wiring diagram. The indoor unit draws its power from the outdoor unit.

### 3-8. Wiring Instructions for Inter-unit Connections

- Remove the grille. (See 3-4. Remove the Grille to Install the Indoor Unit on page 8.)
- Insert the inter-unit wiring (according to local codes) into the through-the-wall PVC pipe. Run the wiring toward the indoor side allowing approx. 10 in. (25 cm) to extend from the wall face. (Fig. 24)



**CAUTION**

Never fix the wiring by any means before the indoor unit is fully seated on the rear panel.

### WIRING SYSTEM DIAGRAM

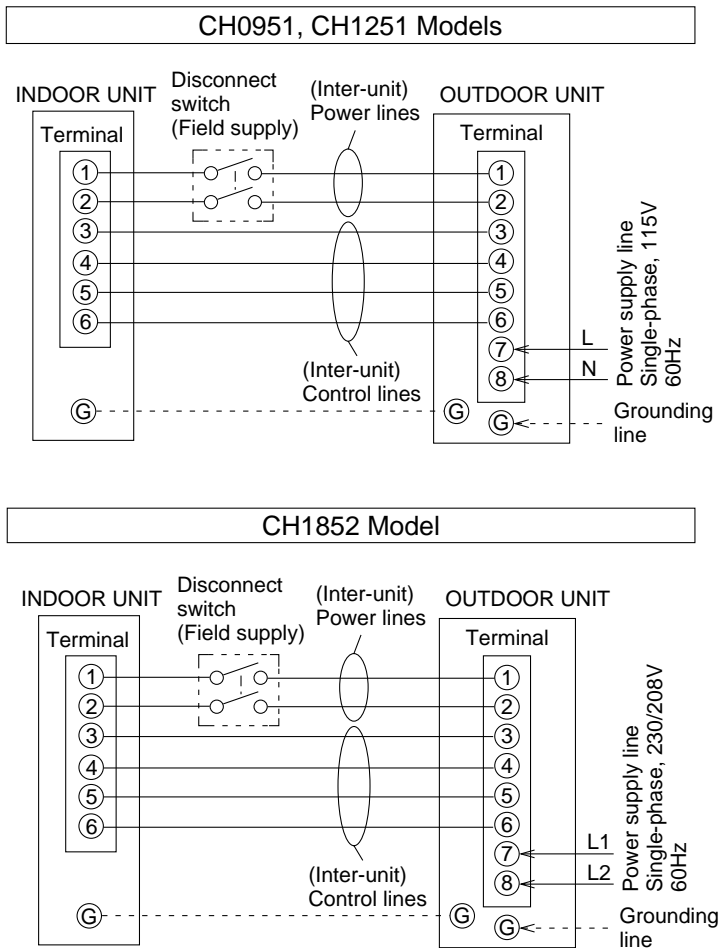

Fig. 23

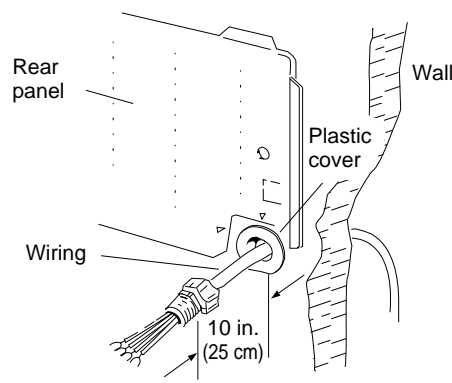

Fig. 24

- c) Remove the screws to open the cover plate securing the electrical component box. (Figs. 25a, 25b, 25c and 25d)
- d) Insert the wrapped tubing into the hole in the wall.
- e) Hang the indoor unit on the rear panel.
- f) Using a Phillips screwdriver, take out the screws on the earth plate. (Fig. 26a KHS09, 12 models only) Remove the earth plate.
- g) Remove the lock nut from the conduit connector. Insert the conduit connector through the opening from the underside of the electrical component box. After insertion, Fit the screw at the top of the conduit connector into the cut-out. (Fig. 26b). Position the earth plate over the conduit connector, allowing the connector and wires to extend through the hole in the plate. Next, attach the conduit connector to the earth plate by replacing and tightening the lock nut (Figs. 26c and 26d). Then re-attach the earth plate to the electrical component box with the 2 screws.
- h) Give some play to the inter-unit wiring from the outdoor unit to the corresponding terminals on the terminal base. (See Wiring System Diagram on page 10.)



**WARNING**

- Be sure to refer to the Wiring System Diagram label inside the electrical component box and carry out the correct field wiring. Wrong wiring can cause the unit to misoperate or result in a fire hazard.
- Check local electrical codes and any specified wiring instructions or limitations.

- i) Fix cover plate and cover plate and back into position with their screws.

**NOTE**

When closing the air intake grille, press on both corners and the center. (Fig. 27)

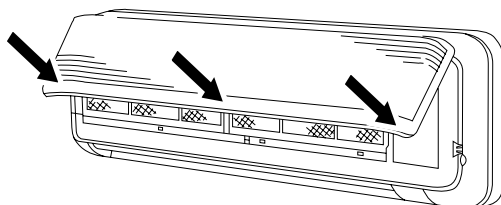

Fig. 27

KHS0951, KHS1251

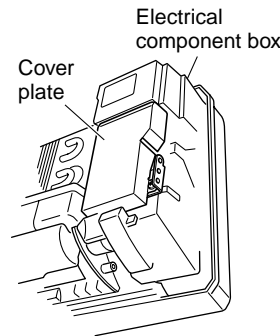

Fig. 25a

KHS0951, KHS1251

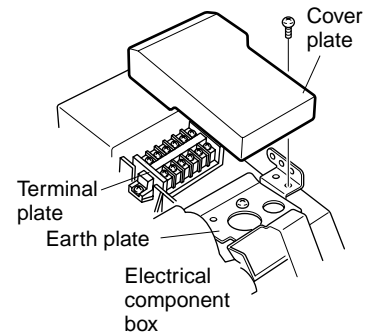

Fig. 25b

KHS1852

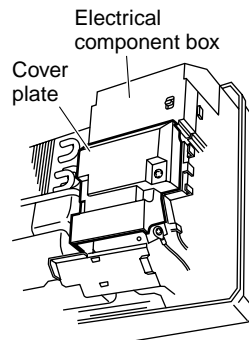

Fig. 25c

KHS1852

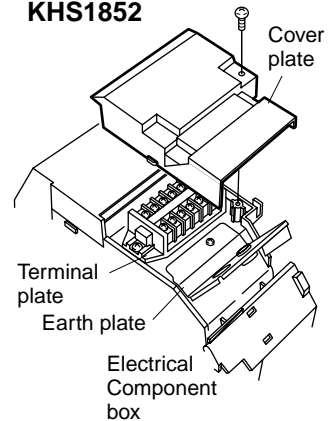

Fig. 25d

KHS0951, KHS1251

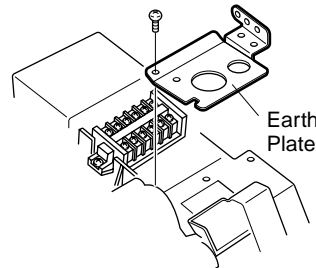

Fig. 26a

KHS1852 Top of conduit connector

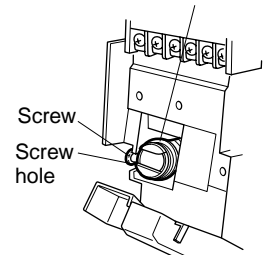

Fig. 26b

KHS0951, KHS1251

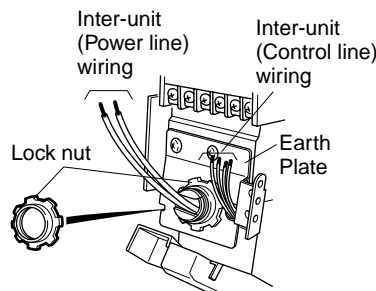

Fig. 26c

KHS1852

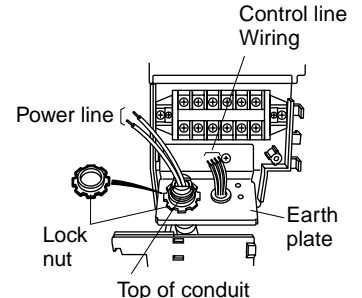

Fig. 26d

**WARNING**

Loose wiring may cause the terminal to overheat or result in unit malfunction. A fire hazard may also exist. Therefore, be sure all wiring is tightly connected.

When connecting each power wire to the corresponding terminal, follow the instructions “How to connect wiring to the terminal” and fasten the wire securely tight with the fixing screw of the terminal plate.

**How to connect wiring to the terminal****a) For Indoor Unit**

- (1) Cut the wire end with a cutting pliers, then strip the insulation to expose the wire about 9/32 in. (7 mm). See the label (Fig. 28) near the terminal plate.
- (2) Using a screwdriver, loosen the terminal screw on the terminal plate.
- (3) Insert the wire and tighten the terminal screw completely using a screwdriver.

**b) For Outdoor Unit****■ For solid core wiring (or F-cable)**

- (1) Cut the wire end with a cutting pliers, then strip the insulation to expose the solid wire about 15/16 in. (25 mm). (Fig. 29)
- (2) Using a screwdriver, remove the terminal screw(s) on the terminal plate.
- (3) Using the pliers, bend the solid wire to form a loop suitable for the terminal screw.
- (4) Shape the loop wire properly, place it on the terminal plate and fix it securely with the removed terminal screw using a screwdriver.

**■ For stranded wiring**

- (1) Cut the wire end with a cutting pliers, then strip the insulation to expose the stranded wiring about 3/8 in. (10 mm) and tightly twist the wire ends. (Figs. 30 and 31)
- (2) Using a screwdriver, remove the terminal screw(s) on the terminal plate.
- (3) Using a ring connector fastener or pliers, securely clamp each stripped wire end with a ring connector. (Fig. 30)
- (4) Place the ring connector wire, and replace and tighten the removed terminal screw using a screwdriver. (Fig. 32)

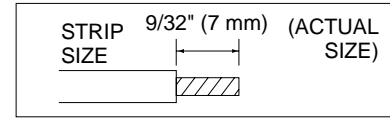
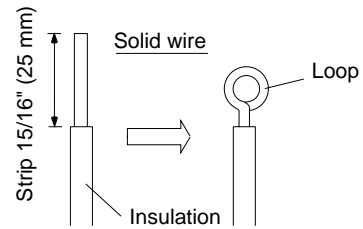
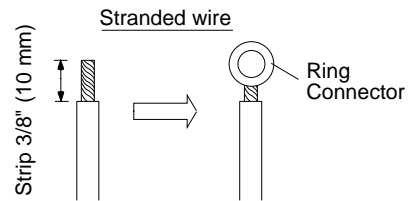
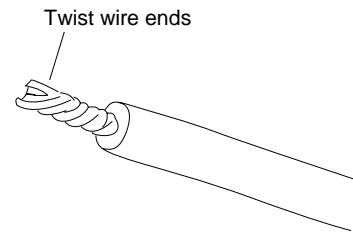
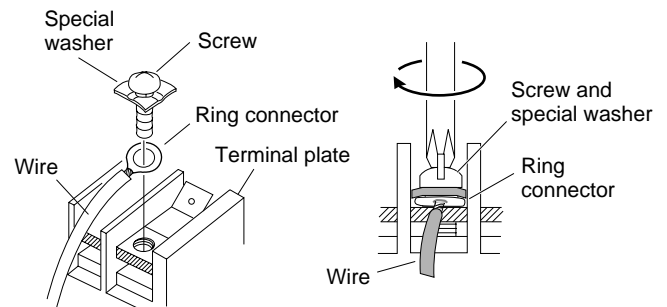
**Fig. 28****Fig. 29****Fig. 30****Fig. 31****Fig. 32**

### 3-9. Mounting

- (1) To install the indoor unit, mount the indoor unit onto the 2 tabs on the upper part of the rear plate.
- (2) Hold down the air discharge outlet and press the lower part of the indoor unit until it clicks to securely fasten to the 2 tabs on the lower part of the rear plate. (Fig. 33)

#### NOTE

For tubing, choose either the right or left tubing direction and follow the steps below. Also, extend the support on the back of the indoor unit as a stand to make your work easier. (Fig. 34)

#### ■ Right-side tubing

- (1) Shape the refrigerant tubing so that it can easily go into the wall hole. (Fig. 35)
- (2) Push the wiring, refrigerant tubing, and drain hose through the hole in the wall. Adjust the indoor unit so it is securely seated on the rear panel. (Fig. 36)
- (3) Carefully bend the tubing (if necessary) to run along the wall in the direction of the outdoor unit and then tape as far as the fittings. (See Caution on page 17.) The drain hose should come straight down the wall to a point where water runoff won't stain the wall.
- (4) Connect the refrigerant tubing to the outdoor unit. (After performing a leak test on the connecting part, insulate it with the tubing insulation (Fig. 37a)). Also, refer to Section 5-4. Connecting Tubing between Indoor and Outdoor Units.
- (5) Assemble the refrigerant tubing, drain hose, and conduit (including inter-unit wiring) as shown in Fig. 37b.

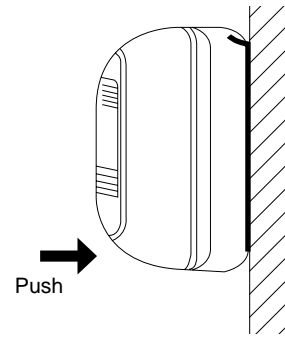

Fig. 33

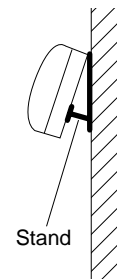

Fig. 34

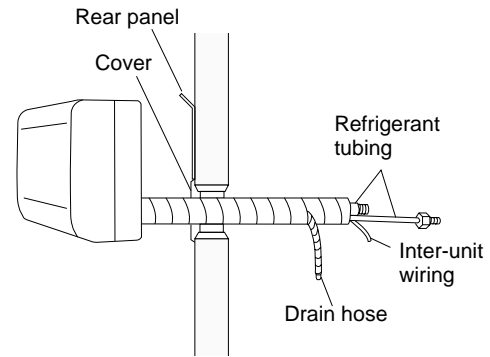

Fig. 35

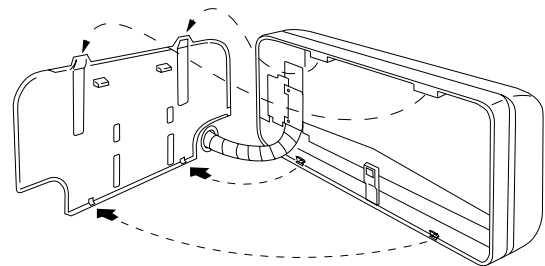

Fig. 36

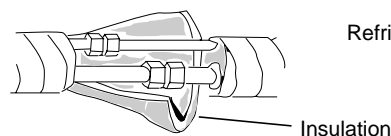

Fig. 37a

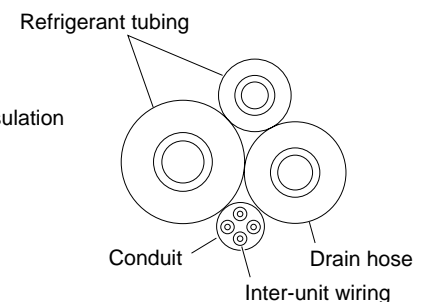

Fig. 37b

### To unmount indoor unit

Press the 2 △ marks on the lower part of the indoor unit and unlatch the tabs. Then lift the indoor unit and unmount. (Fig. 38)

### 3-10. Drain Hose

- a) The drain hose should be slanted downward to the outdoors. (Fig. 39)
- b) Never form a trap in the course of the hose.
- c) If the drain hose will run in the room, insulate the hose with insulation\* so that chilled condensation will not damage furniture or floors. (Fig. 40)

\* Foamed polyethylene or its equivalent is recommended.

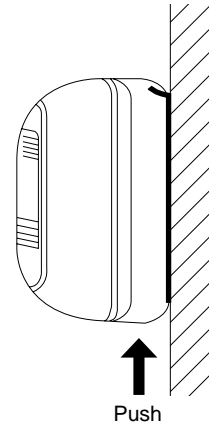

**Fig. 38**

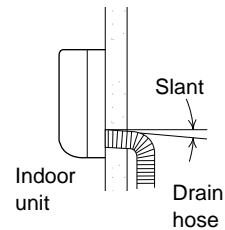

**Fig. 39**



**WARNING** Do not supply power to the unit or operate it until all tubing and wiring to the outside unit are completed.



**Risk of Electric Shock**

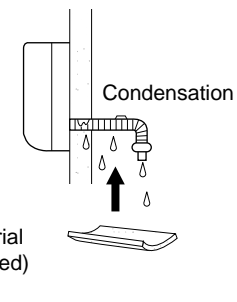

**Fig. 40**

## 4. How to Install the Outdoor Unit

First refer to Section 2. Installation Site Selection.

### 4-1. Wiring Instructions for the Outdoor Unit

Regulations on wire size differ from locality to locality. For field wiring requirements, please refer to your local electrical codes. Make sure that the installation fully complies with all local and national regulations.

- (1) Remove access panel. (Fig. 41)
- (2) Connect the power line according to the drawing on the panel side.
- (3) Be sure to size each wire allowing approx. 4 in. (10 cm) longer than the required length for wiring. Store excess wiring inside the cabinet.
- (4) When connections are completed, check that all connections are correct as shown in the wiring system diagram on panel side.
- (5) Be sure to ground the unit according to your local codes.

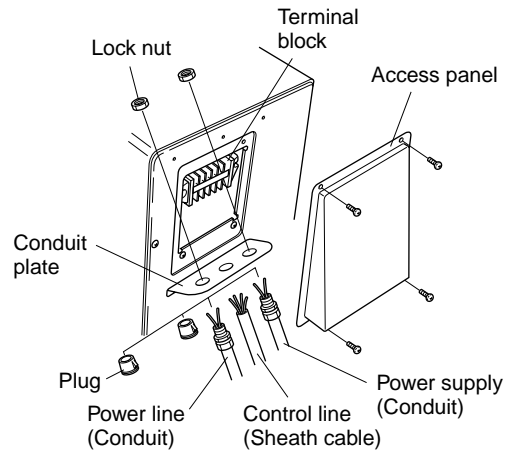

Fig. 41



**CAUTION**

**Apply sealer (putty, etc.) to the gap between the sheath cable and the hole of the conduit plate to prevent water from entering.**



**CAUTION**

### Examples of Incorrect Wiring

The following are examples of improper wiring that result in system misoperation. You should confirm that you have wired the units correctly before beginning the test run.

#### Problem 1

- Short circuit will occur after approx. 3 minutes and the power circuit fuse blows.

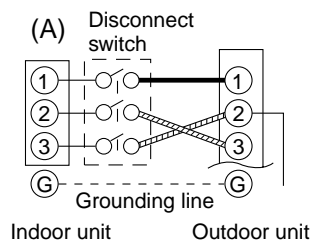

#### Problem 2

- Air conditioner will not operate.

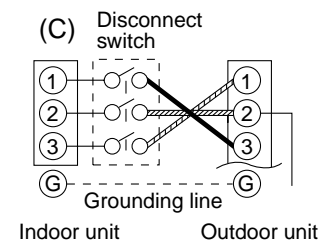
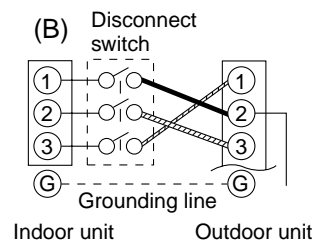

#### Problem 3

- Compressor will not start; only indoor unit will operate.

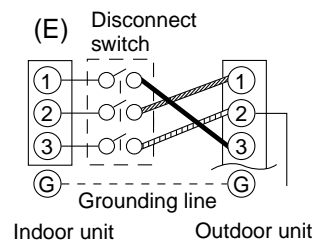
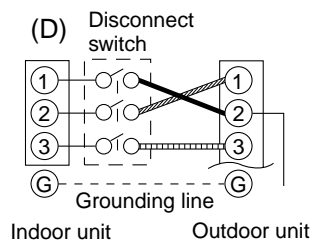

## 5. Refrigerant Tubing

### 5-1. Use of the Flaring Method

Many of the conventional split system air conditioners employ the flaring method to connect refrigerant tubes which run between indoor and outdoor units. In this method, the copper tubes are flared at each end and connected with flare nuts.

### 5-2. Flaring Procedure with a Flare Tool

- Cut the copper tube to the required length with a tube cutter. It is recommended to cut approx. 12 to 20 in. (30 to 50 cm) longer than the tubing length you estimate.
- Remove burrs at the end of the copper tube with a tube reamer or file. This process is important and should be done carefully to make a good flare. (Fig. 42)

#### NOTE

When reaming, hold the tube end downward and be sure that no copper scraps fall into the tube. (Fig. 43)

- Remove the flare nut from the unit and be sure to mount it on the copper tube.
- Make a flare at the end of copper tube with a flare tool.\* (Fig. 44)  
(\*Use "RIGID" or equivalent.)

#### NOTE

A good flare should have the following characteristics:

- inside surface is glossy and smooth.
- edge is smooth.
- tapered sides are of uniform length.

### 5-3. Caution before Connecting Tubes Tightly

- Be sure to apply a sealing cap or water-proof tape to prevent dust or water from getting into the tubes before they are used.
- Be sure to apply refrigerant lubricant to the matching surfaces of the flare and union before connecting them together. This is effective for reducing gas leaks. (Fig. 45)
- For proper connection, align the union tube and flare tube straight with each other, then screw in the flare nut lightly at first to obtain a smooth match. (Fig. 46)

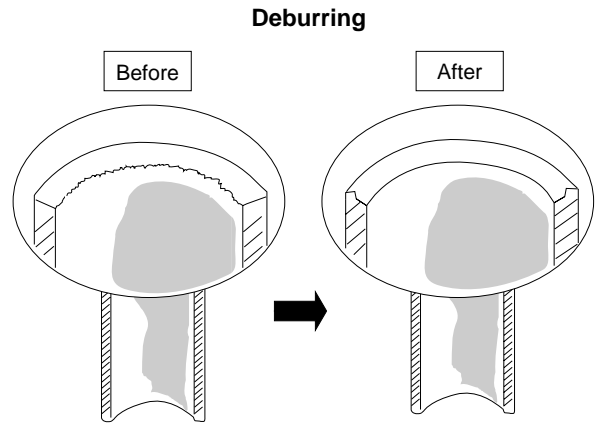

Fig. 42

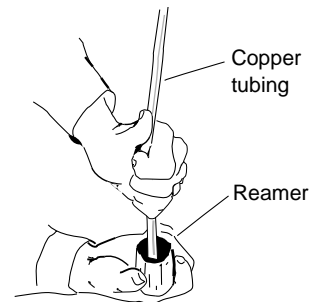

Fig. 43

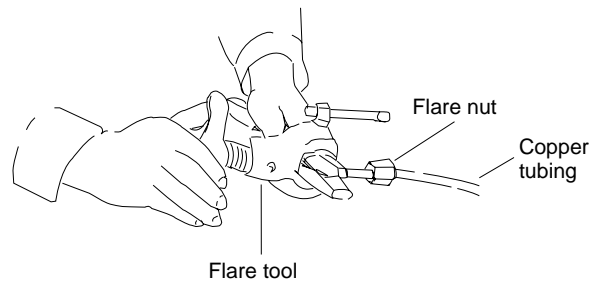

Fig. 44

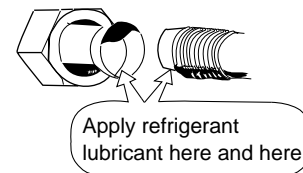

Fig. 45

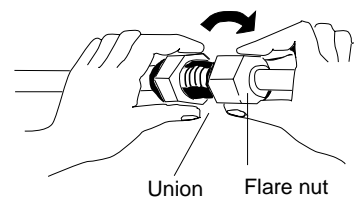

Fig. 46



### 5-4. Connecting Tubing between Indoor and Outdoor Units

- Tightly connect the indoor side refrigerant tubing extended from the wall with the outdoor side tubing. (Fig. 47)
- To fasten the flare nuts, apply specified torque as:

**Table 5**

Tube Dia.	Tightening Torque
1/4" (6.35 mm)	Approx. 130 – 170 lbs.in. (150 – 200 kg.cm)
3/8" (9.52 mm)	Approx. 300 – 340 lbs.in. (350 – 400 kg.cm)
1/2" (12.7 mm)	Approx. 430 – 470 lbs.in. (500 – 550 kg.cm)
5/8" (15.88 mm)	Approx. 520 – 560 lbs.in. (600 – 650 kg.cm)

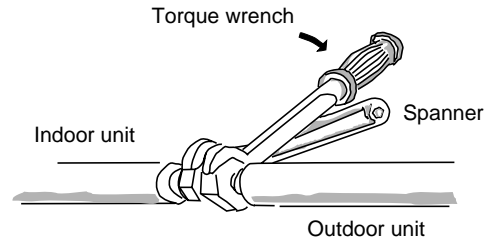

**Fig. 47**

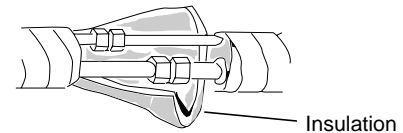

**Fig. 48**

### 5-5. Insulation of Refrigerant Tubing

**IMPORTANT**

To prevent heat loss and wet floors due to dripping of condensation, **both tubes must be well insulated with a proper insulation material.** (Fig. 48) The thickness of the insulation should be a minimum 5/16" (8 mm). (Fig. 49)



**CAUTION**

After a tube has been insulated, never try to bend it into a narrow curve, as this may cause the tube to break or crack.

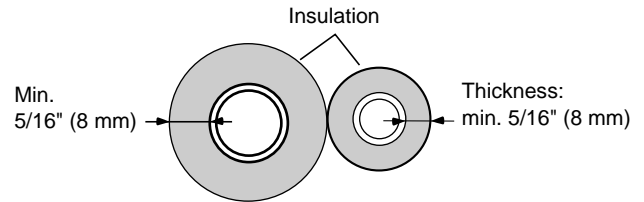

**Fig. 49**

### 5-6. Taping the Tubes

- At this time, the 2 refrigerant tubes (and electrical wire if local codes permit) should be taped together with armoring tape. The drain hose may also be included and taped together as 1 bundle with the tubing.
- Wrap the armoring tape from the bottom of the outdoor unit to the top of the tubing where it enters the wall. As you wrap the tubing, overlap half of each previous tape turn. (Fig. 50)
- Clamp tubing bundle to wall, using 1 clamp approx. every 47 in. (120 cm).

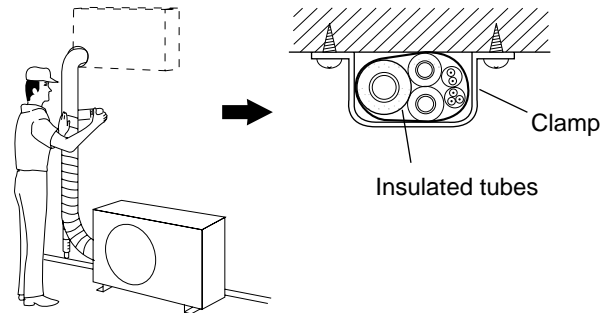

**Fig. 50**

**NOTE**

Do not wind the armoring tape too tightly, since this will decrease the heat insulation effect. Also, be sure the condensation drain hose splits away from the bundle and drips clear of the unit and the tubing.

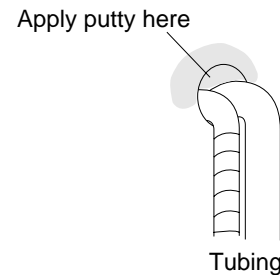

**Fig. 51**

### 5-7. Finishing the Installation

After finishing insulating and taping over the tubing, use sealing putty to seal off the hole in the wall to prevent rain and draft from entering. (Fig. 51)

## 6. Air Purging

Air and moisture remaining in the refrigerant system have undesirable effects as indicated below. Therefore, they must be purged completely.

- pressure in the system rises
- operating current rises
- cooling (or heating) efficiency drops
- moisture in the air may freeze and block capillary tubing
- water may lead to corrosion of parts in the refrigerant system

### ■ Air Purging with a Vacuum Pump (for Test Run)

- (1) Check that each tube (both narrow and wide tubes) between the indoor and outdoor units have been properly connected and all wiring for the test run has been completed. Note that both narrow and wide tube service valves on the outdoor unit are kept closed at this stage.
- (2) Using an adjustable wrench or box wrench, remove the valve caps from the service valve on both narrow and wide tubes.
- (3) Connect a vacuum pump and a manifold valve (with pressure gauges) to the service port on the wide tube service valve. (Fig. 52)



**CAUTION**

**Be sure to use a manifold valve for air purging. If it is not available, use a stop valve for this purpose. The “Hi” knob of the manifold valve must always be kept closed.**

- (4) With the “Lo” knob of the manifold valve open, run the vacuum pump. The operation time for the vacuum pump varies with tubing length and the capacity of the pump. The following table shows the amount of time for evacuation:

**Table 6**

Required time for evacuation when capacity of 100 liter/h vacuum pump is used	
If tubing length is less than 33 ft. (10 m)	If tubing length is more than 33 ft. (10 m)
<b>10 min. or more</b>	<b>15 min. or more</b>

### NOTE

The required time in the above table is calculated based on the assumption that the ideal (or target) vacuum condition is around 10 mmHg abs.

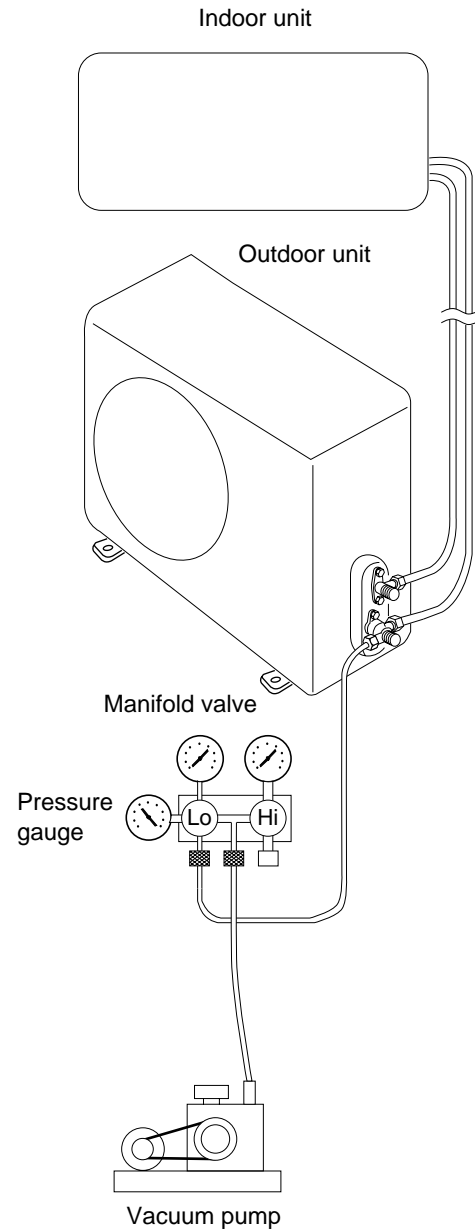

**Fig. 52**

- (5) With the vacuum pump still running, close the “Lo” knob of the manifold valve. Then stop the vacuum pump.
- (6) With the accessory hex wrench, turn the valve stem on the narrow tube service valve counter-clockwise by 90 degrees (1/4 turn) for 10 seconds, and then turn the stem clockwise to close it again. (Fig. 53)



**CAUTION**

**Be sure to completely insert the hex wrench before attempting to turn the valve.**

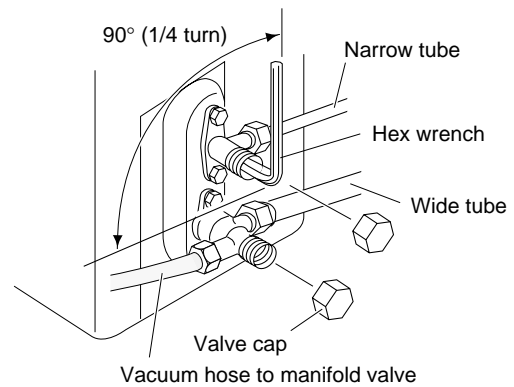

**Fig. 53**

- (7) Leak test all joints at the tubing (both indoor and outdoors) with liquid soap. Bubbles indicate a leak. Be sure to wipe off the soap with a clean cloth.
- (8) With the hex wrench, turn the wide tube service valve stem counter-clockwise to fully open the valve.
- (9) Turn the narrow tube service valve stem counter-clockwise to fully open the valve.
- (10) Loosen the vacuum hose connected to the wide tube service port slightly to release the pressure. Then, remove the hose.
- (11) Replace the bonnet and flare nut on the wide tube service port and fasten the flare nut securely with an adjustable wrench or box wrench. Next, mount the valve cap and tighten it with a torque wrench (the cap needs to be tightened with the torque of 170 lbs.·in. (200 kg·cm)). This process is very important to prevent gas from leaking from the system.
- (12) Test run the air conditioner. (See next page.)
- (13) While the air conditioner is running, apply liquid soap to check for any gas leaks around the service valves or caps.
- (14) If there is no leakage, stop the air conditioner.
- (15) Wipe off the soap on the tubing.

This completes air purging with a vacuum pump and the air conditioner is ready for actual operation.

**\* How to Test Run the Air Conditioner.**

- (1) Switch on the power source.
- (2) Press the ON/OFF button on the remote control unit once.
- (3) Set the operation selector switch of the indoor unit to the TEST position. This starts the fan, producing uncooled forced air. (Figs. 54a and 54b)
- (4) After 3 minutes, the system shifts into cooling operation, and cool air will start to be felt. Cooling operation during with the switch at the TEST position is unaffected by the room temperature.
- (5) After stopping the test run, turn the operation selector switch of indoor unit to the OFF position once, then move to ON position.
- (6) Press the ON/OFF button on the remote control unit to stop the air conditioner.

**NOTE**

If the unit does not operate and the OPERATION lamp on the unit is blinking after going through the procedure, check the wiring between the units.

**KHS0951, KHS1251**

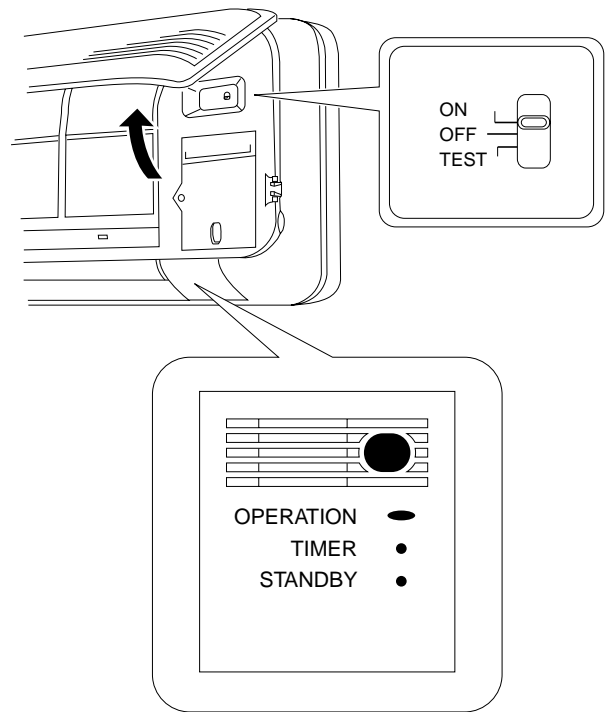

**Fig. 54a**

**KHS1852**

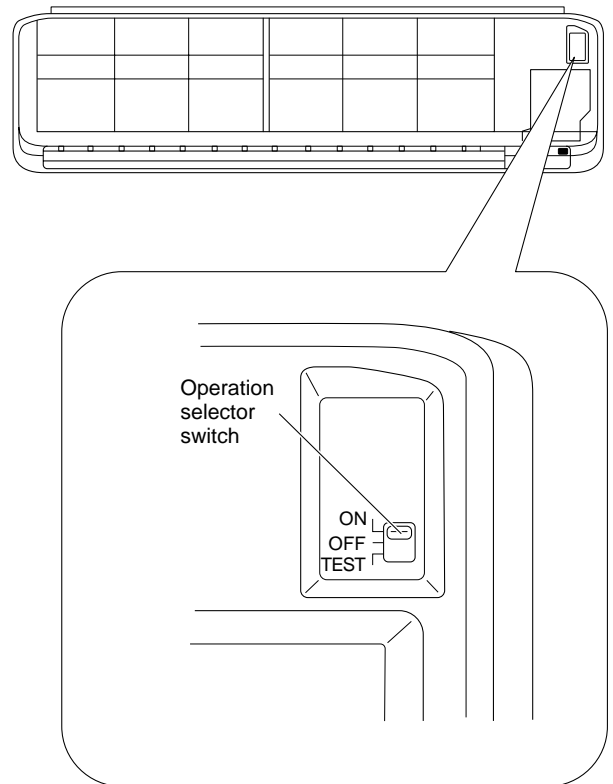
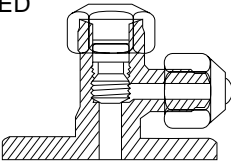
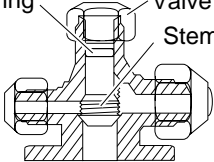
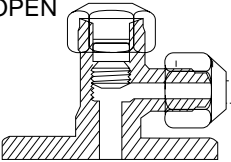
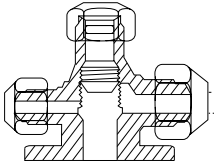
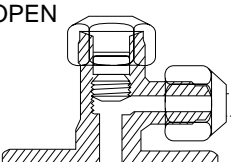
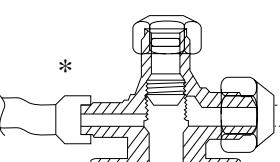
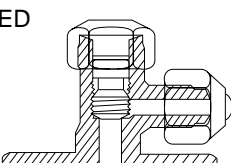
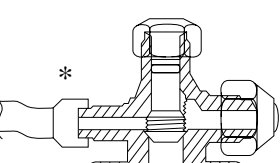

**Fig. 54b**

## ■ Basic Function of the Service Valves

The basic function of the service valves are given in Table 7 below.

**Table 7**

Action	Narrow Tube Service Valve (2-Way)	Wide Tube Service Valve (3-Way)
Shipping	CLOSED 	O-ring Valve cap Stem 
Operating and test running the air conditioner	Fully OPEN 	
Measuring pressure and gas charging	Fully OPEN 	* 
Air purging with a vacuum pump	CLOSED 	* 

\* The service port on the wide tube service valve uses a Schrader core valve to access the refrigerant system. Therefore, be sure to use a hose connector which has a push-pin inside. (Fig. 55)

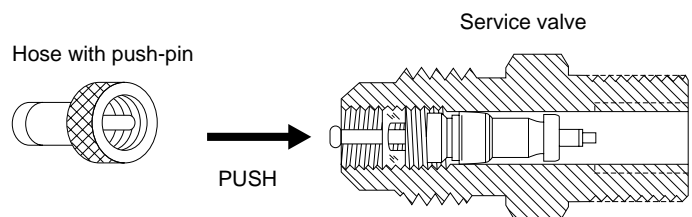

**Fig. 55**

## ■ Pump Down

Pump down means collecting all refrigerant gas in the system back into the outdoor unit without losing any of the gas. Pump down is used when the unit is to be moved or before servicing the refrigerant circuit.

### Pump Down Procedure

**Be sure to carry out pump down with the unit in cooling mode.**

- (1) Connect the Lo side charging hose of the manifold valve to the service port on the wide tube service valve.
- (2) Using a hex wrench, turn the narrow tube service

valve clockwise all the way to close the service valve. (Be sure to confirm that the wide tube service valve is fully open.)

- (3) Press the operation button and start cooling operation.
- (4) When the low pressure gauge reading falls to 1 to 0.5 kg/cm<sup>2</sup> (14.2 to 7.1 PSI), fully close the wide tube valve stem with a standard screwdriver. Then quickly stop the unit.
- (5) Disconnect all gauges and hoses, and replace the bonnets and the valve caps as they were before.

## 7. Remote Control Unit Installation Position

The remote control unit can be operated from either a non-fixed position or a wall-mounted position.

To ensure that the air conditioner operates correctly, do not install the remote control unit in the following places:

- In direct sunlight
- Behind a curtain or other place where it is covered
- More than 26 ft. (8 m) away from the air conditioner
- In the path of the air conditioner's airstream
- Where it may become extremely hot or cold
- Where it may be subject to electrical or magnetic interference

### 7-1. Mounting on a Wall

- 1) Confirm the indoor unit beeps when the ON/OFF button is pressed at the wall location where the remote control unit is to be attached, then attach the holder to the wall. (Fig. 56)
- 2) When taking out the remote control unit, pull it from the holder.

#### When using the remote control unit

- Point the transmission portion of the remote control unit at the receiver area of the indoor unit when operating the remote control unit, and during operation of the air conditioner.
- Do not place objects that may block the transmitted signals between the receiver and the remote control unit.

#### When mounting the remote control unit to prevent theft

- 1) Mount the holder to the wall with one of the screws (using only the hole in the top of the holder) (Fig. 57).
- 2) Remove the cover of the remote control unit and take out the batteries. Next, place the remote control unit in the holder.
- 3) Fasten both the remote control unit and holder to the wall with the remaining screw (using the hole in the bottom of the holder).
- 4) Install the batteries in the remote control unit and close the cover.

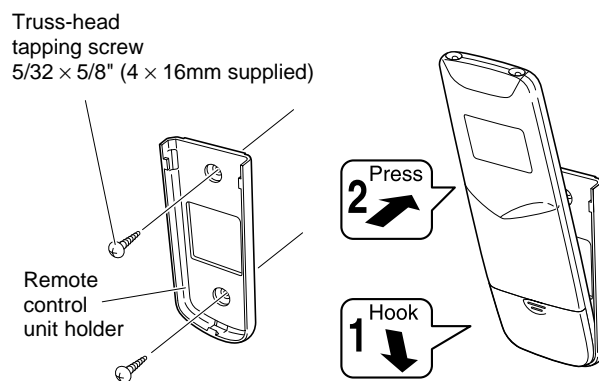

Fig. 56

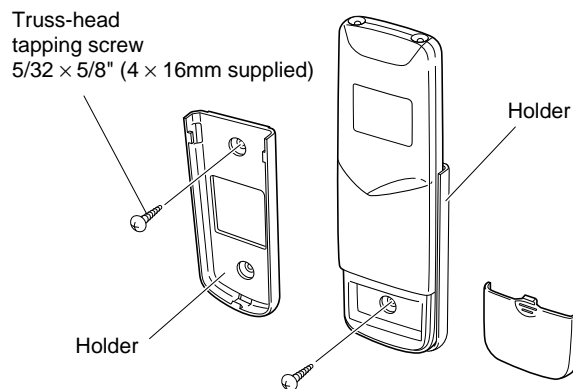

Fig. 57