

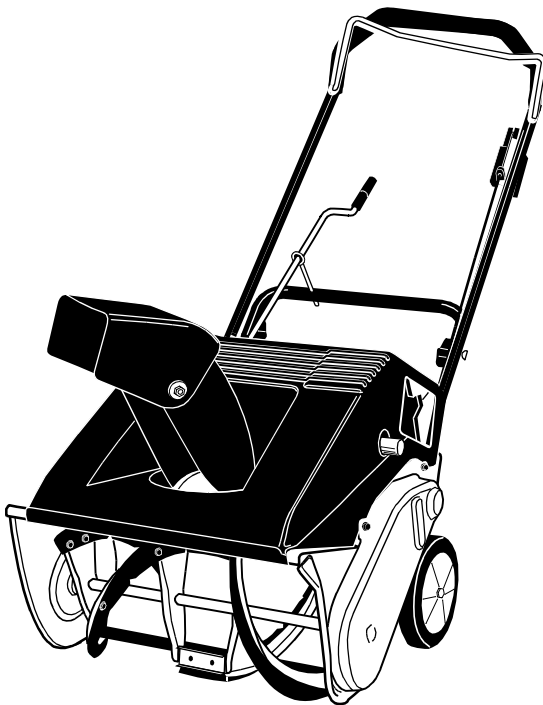

# Operator's Manual



## Single Stage Snow Thrower

Models SB45 & SB55

**IMPORTANT:** Read safety rules and instructions carefully

**Warning:** This unit is equipped with an internal combustion engine and should not be used on or near any unimproved forest-covered, brush-covered or grass-covered land unless the engine's exhaust system is equipped with a spark arrester meeting applicable local or state laws (if any). If a spark arrester is used, it should be maintained in effective working order by the operator. In the State of California the above is required by law (Section 4442 of the California Public Resources Code). Other states may have similar laws. Federal laws apply on federal lands. A spark arrester for the muffler is available through your nearest engine authorized service dealer or contact the service department, P.O. Box 361131 Cleveland, Ohio 44136-9722.

**WHITE OUTDOOR PRODUCTS COMPANY P.O. BOX 361131 CLEVELAND, OHIO 44136-9722**

PRINTED IN U.S.A.

FORM NO. 770-10012A  
(12/99)

## TABLE OF CONTENTS

Content	Page
Important Safe Operation Practices .....	3
Assembling Your Snow Thrower .....	5
Know Your Snow Thrower .....	7
Operating Your Snow Thrower .....	8
Making Adjustments .....	9
Service .....	10
Maintaining Your Snow Thrower .....	11
Off-Season Storage .....	11
Troubleshooting .....	12
Parts List .....	13

## FINDING MODEL NUMBER

This Operator's Manual is an important part of your new snow thrower. It will help you to assemble, prepare and maintain the unit for best performance. Please read and understand what it says.



**Before you start assembling your new snow thrower**, please locate the model plate on the equipment and copy the information from it in the space provided below. The information on the model plate is very important if you need help from our Customer Referral Line or an authorized dealer.

- You can locate the model number by standing behind the unit in the operating position and looking down at the dash panel . A sample model plate is explained below. For future reference, please copy the model number and the serial number of the equipment in the space below.

_____	_____
(Model Number)	(Serial Number)
<b>WHITE</b>  <b>WHITE OUTDOOR PRODUCTS COMPANY</b> P.O. BOX 361131 CLEVELAND, OHIO 44136	

Copy the model number here: \_\_\_\_\_

Copy the serial number here: \_\_\_\_\_

## CALLING CUSTOMER SUPPORT



If you have difficulty assembling this product or have any questions regarding the controls, operation or maintenance of this unit, please call the White Outdoor Customer Dealer Referral Line at **1- (800)-949-4483**. Please have your unit's model number and serial number ready when you call. See previous section to locate this information. By having the model and serial numbers ready, you help your local dealer give you faster service.

---

## SECTION 1: IMPORTANT SAFE OPERATION PRACTICES



**WARNING:** This symbol points out important safety instructions which, if not followed, could endanger the personal safety and/or property of yourself and others. Read and follow all instructions in this manual before attempting to operate your snow thrower. Failure to comply with these instructions may result in personal injury. When you see this symbol, heed its warning.

**DANGER:** Your snow thrower was built to be operated according to the rules for safe operation in this manual. As with any type of power equipment, carelessness or error on the part of the operator can result in serious injury. If you violate any of these rules, you may cause serious injury to yourself or others.

**WARNING:** The Engine Exhaust from this product contains chemicals known to the State of California to cause cancer, birth defects or other reproductive harm.

### Training

- Read this operator's manual carefully in its entirety before attempting to assemble or operate this machine. Be completely familiar with the controls and the proper use of this machine before operating it. Keep this manual in a safe place for future and regular reference and for ordering replacement parts.
- Never allow children under 14 years old to operate a snow thrower. Children 14 years old and over should only operate snow thrower under close parental supervision. Only persons well acquainted with these rules of safe operation should be allowed to use your snow thrower.
- No one should operate this unit while intoxicated or while taking medication that impairs the senses or reactions.
- Keep the area of operation clear of all persons, especially small children and pets.
- Exercise caution to avoid slipping or falling, especially when operating in reverse.

### Preparation

- Thoroughly inspect the area where the equipment is to be used and remove all door mats, sleds, boards, wires and other foreign objects.
- Disengage all clutches and shift into neutral before starting engine.
- Do not operate equipment without wearing adequate winter outer garments. Do not wear jewelry, long scarfs or other loose clothing which could become entangled in moving parts. Wear footwear which will improve footing on slippery surfaces.
- Before working with gasoline, extinguish all cigarettes and other sources of ignition. Check the fuel before starting the engine. Gasoline is an extremely flammable fuel. Do not fill the gasoline tank indoors, while the engine is running, or until engine has been allowed to cool at least two minutes. Replace gasoline cap securely and wipe off any spilled gasoline before starting the engine as it may cause a fire or explosion.

- Use a grounded three wire plug-in for all units with electric drive motors or electric starting motors.
- Adjust collector housing height to clear gravel or crushed rock surface.
- Never attempt to make any adjustments while engine is running (except where specifically recommended by manufacturer).
- Let engine and machine adjust to outdoor temperature before starting to clear snow.
- Always wear safety glasses or eye shields during operation or while performing an adjustment or repair, to protect eyes from foreign objects that may be thrown from the machine in any direction.

### Operation

- Do not put hands or feet near or under rotating parts. Keep clear of discharge opening and auger at all times.
- Exercise extreme caution when operating on or crossing gravel drives, walks, or roads. Stay alert for hidden hazards or traffic.
- After striking a foreign object, stop the engine, remove wire from spark plug, and thoroughly inspect the snow thrower for any damage. Repair the damage before restarting and operating the snow thrower.
- If the snow thrower should start to vibrate abnormally, stop the engine and check immediately for the cause. Vibration is generally a warning of trouble.
- Stop engine whenever you leave the operating position, before unclogging the collector/impeller housing or discharge guide, and making any repairs, adjustments, or inspections. Never place your hand in the discharge or collector openings. Use a stick or wooden broom handle to unclog the discharge opening.
- Take all possible precautions when leaving the unit unattended. Disengage the collector/impeller, shift into neutral, stop the engine, and remove the key.
- When cleaning, repairing, or inspecting, make certain collector/impeller and all moving parts have

stopped. Disconnect spark plug wire and keep away from plug to prevent accidental starting.

- Do not run engine indoors, except when starting engine and transporting snow thrower in or out of building. Open doors. Exhaust fumes are dangerous.
- Do not clear snow across the face of slopes. Exercise extreme caution when changing direction on slopes. Do not attempt to clear steep slopes.
- Never operate snow thrower without guards, plates, or other safety protection devices in place.
- Never operate snow thrower near glass enclosure, automobiles, window wells, drop off, etc., without proper adjustments of snow thrower discharge angle. Keep children and pets away.
- Do not overload machine capacity by attempting to clear snow at too fast a rate.
- Never operate the machine at high transport speeds on slippery surfaces. Look behind and use care when backing.
- Never direct discharge at bystanders or allow anyone in front of unit.
- Disengage power to collector/impeller when transporting or not in use.
- Use only attachments and accessories approved by the manufacturer of snow thrower (such as wheel weights, counter weights, cabs, etc.).

- Never operate the snow thrower without good visibility or light. Always be sure of your footing and keep a firm hold on the handles. Walk, never run.
- Muffler and engine become hot and can cause a burn. Do not touch.

## Maintenance And Storage

- Check shear bolts, engine mounting bolts, etc., at frequent intervals for proper tightness to be sure equipment is in safe working condition.
- Never store the machine with fuel in the fuel tank inside a building where ignition sources are present, such as hot water and space heaters, clothes dryers, and the like. Allow engine to cool before storing in any enclosure.
- Always refer to operator's manual instructions for important details if snow thrower is to be stored for an extended period.
- Run machine a few minutes after throwing snow to prevent freeze up of collector/impeller.
- Check clutch controls periodically to verify they engage and disengage properly and readjust if necessary. Refer to operator's manual for adjustment instructions.



## Your Responsibility

Restrict the use of this power machine to persons who read, understand and follow the warnings and instructions in this manual and on the machine. Some of the safety labels are reproduced below. Review them and follow their instructions.



## SECTION 2: ASSEMBLING YOUR SNOW THROWER

### Unpacking from carton

- Cut along corners of the carton and lay it down flat. See Figure 1. Remove packing material.
- Remove any loose parts included with unit (i.e., operator's manual, etc.).
- Roll unit out of carton. Check carton thoroughly for any remaining loose part.

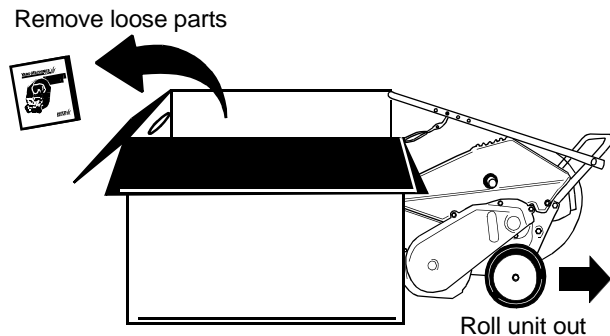

Figure 1

### Hardware pack (Figure 2)

1. Ignition Keys (2)

**NOTE:** One key is in the switch on the snow thrower.

2. Eyebolt
3. Saddle Washer 5/16" I.D.
4. Hex Nuts 5/16-18 Thread (2)
5. Cotter Pin

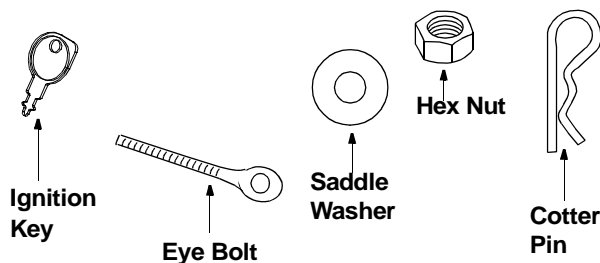

Figure 2

### Items required for assembly

1. Pair of pliers (not necessary, but helpful)
2. Two cycle engine oil
3. Fresh gasoine

**NOTE:** All references to left or right side of the snow thrower is from the operating position only.

### Raising upper handle

- Loosen the hand knob on each side of the handle. Remove packing material, if any.

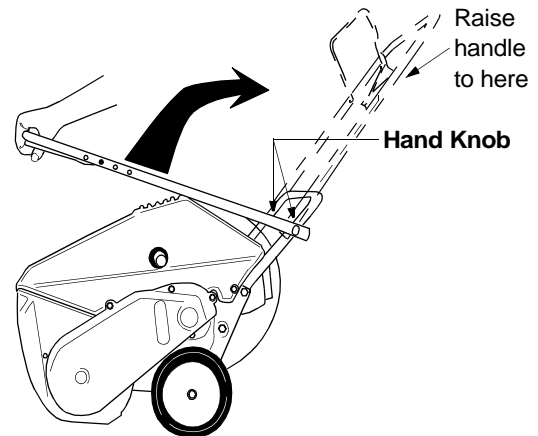

Figure 3

- Raise the upper handle in the direction shown in Figure 3 till it clicks into the operating position. Make sure not to pinch or crimp the cable.
- Tighten the hand knobs.

### Attaching control cable

The control cable may already be attached to the control handle. If not attached, complete the following steps to attach it to the snow thrower housing.

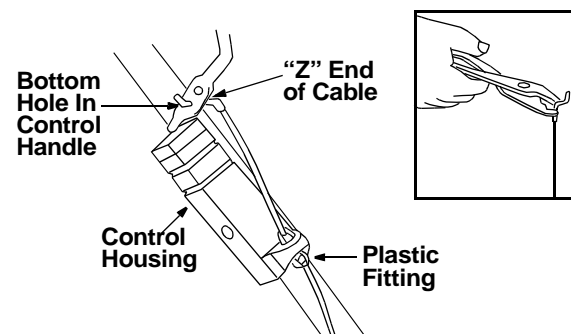

Figure 4

- Route the control cable over the lower handle. Insert the end of the cable into the hole in the control housing as shown in Figure 4. Push the plastic fitting until it locks into the control housing.
- Lift the control handle up, and hook the "Z" end of the control cable into the **bottom** hole in the control handle, from the outside to the inside. If necessary, pull up on the end of the cable with a pair of pliers to obtain slack in order to hook it into

the control handle. Hold the “Z” fitting with the pliers, not the cable, to avoid damaging the cable.

**NOTE:** The upper hole in the control handle provides for adjustment in belt tension. Refer to Belt Tension Adjustment Section of this manual for instructions.

## Installing chute crank

- Thread one 5/16” hex nut all the way onto the eyebolt. See Figure 5. All necessary hardware is included in the hardware pack shipped with your unit. See Figure 2 for more details.
- Slide the eyebolt onto the chute crank. Insert eyebolt into the hole in the lower handle.

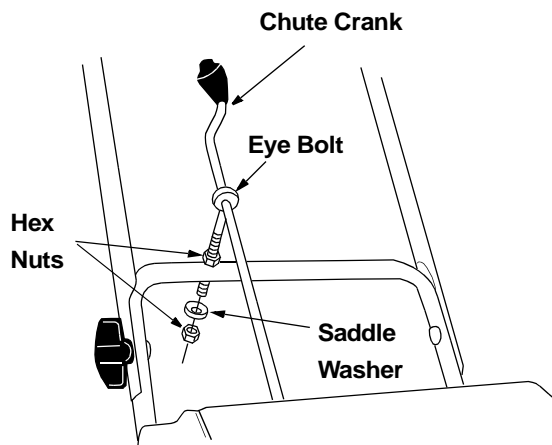

Figure 5

- Insert the chute crank into the coupler at the top right side of the snow thrower. See Figure 6.
- Rotate the crank to align holes, and insert the cotter pin. Bend ends of cotter pin in opposite directions to secure. See Figure 6.

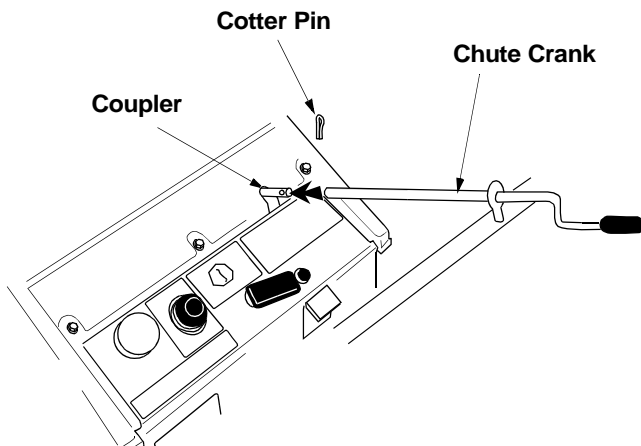

Figure 6

- Secure eyebolt with 5/16” saddle washer and hex nut. The cupped side of washer goes against the handle. Adjust lower hex nut until the eyebolt is positioned so that the chute crank turns freely (does not bind).
- Move upper hex nut down against the lower handle. Tighten lower hex nut securely.

## Assembling the chute

The snow thrower has been shipped with the upper chute pivoted all the way down. Assemble as follows:

- Turn the chute crank until the chute faces straight to the front. See Figure 7.

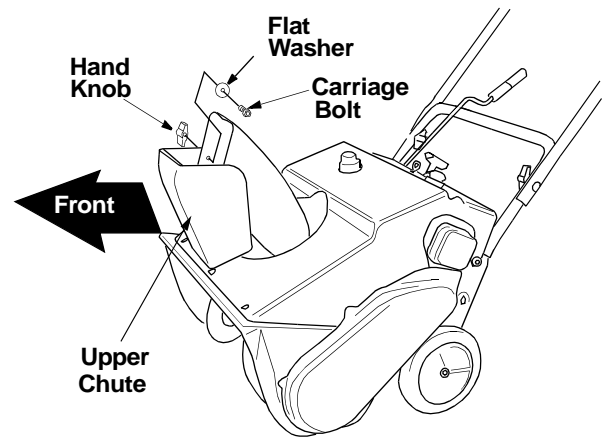

Figure 7

- Remove the hand knob, flat washer and carriage bolt from the upper chute. See Figure 7.
- Pivot the upper chute up so that there is no gap between the upper and the lower chute. See Figure 8. Secure with hardware just removed.

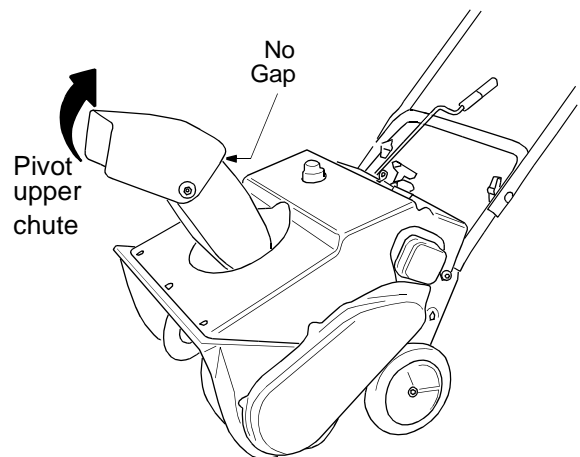

Figure 8

## SECTION 3: KNOW YOUR SNOW THROWER

Read this owner's manual and safety rules and labels before operating your snow thrower. Compare the illustrations in Figure 9 with your equipment to familiarize yourself with the location of various controls and adjustments. Save this manual for future reference.



**WARNING:** The operation of any snow thrower can result in foreign objects being thrown into the operator's eyes and causing severe eye damage. Always wear safety glasses while operating the snow thrower, or while performing any adjustments or repairs on it.

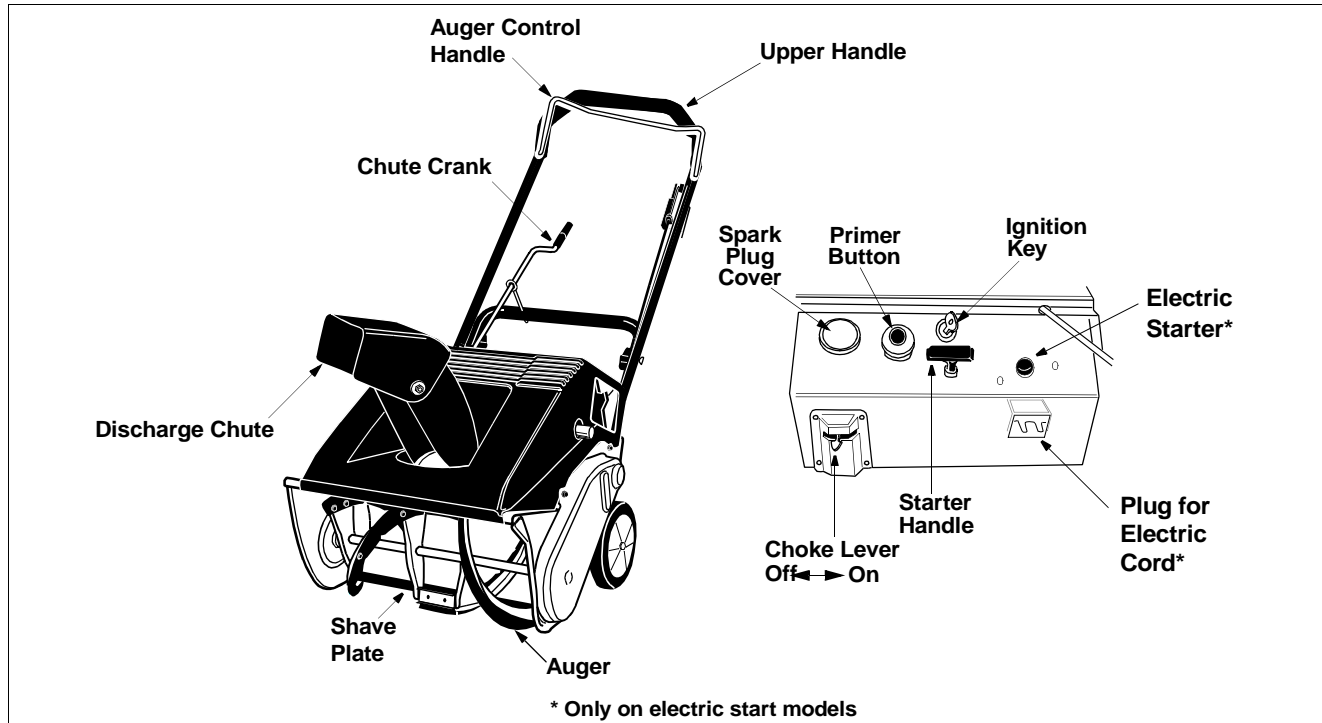

Figure 9

**IMPORTANT:** This unit is shipped without gasoline or oil. See separate engine operator's manual for proper fuel and engine oil recommendations.

### Auger Control Handle

Located on the upper handle, the auger control handle is used to engage and disengage the augers. The snow thrower is designed to be propelled by the rotation of the augers. Pull the control handle back against the upper handle to engage the augers; release to disengage.

### Chute Crank

Located on right side of dash panel, the chute crank determines the direction that snow will be discharged. Turn clockwise to discharge snow to the left; turn counterclockwise to discharge to the right.

### Discharge Chute

The angle of the discharge chute controls the distance that the snow is thrown. Tilt the discharge chute up for greater distance; tilt down for less distance. Loosen the hand knob on the side of the discharge chute to adjust. Tilt the chute to the desired position, and tighten the knob.

### Choke Lever

Place choke lever in "ON" position to start a cold engine.

### Primer Button

Used to inject fuel directly into the carburetor to insure fast starts in cold weather. Follow engine manual to prime engine.

### Ignition Key

Used to start engine. Put key in "ON" position to start.

### Starter Handle

Used to manually start the engine.

### Spark Plug Cover

Spark plug located under the cover.

### Electric Starter (If equipped)

This is used to start engine with a 120V power source.

### Plug for Electric Start (If equipped)

The electric starter requires use of a two prong outdoor extension cord and a 120V power source.

## SECTION 4: OPERATING YOUR SNOW THROWER

### Fuel and oil mixture



**WARNING:** Handle gasoline carefully; remember that it is highly flammable. Never fill fuel tank indoors, when engine is running or while engine is still hot. Do not smoke when filling fuel tank.

Your snow thrower uses a two cycle engine that requires a mixture of gasoline and two cycle engine oil. Refer to the engine operator's manual for proper oil and fuel recommendations.

- A plastic **cup** was provided inside the fuel fill opening on the fuel tank. Remove and discard this cup before filling up the tank. Use the separate fuel tank cap to close after fill-up.

### Starting engine

- To start the engine of your snow thrower, follow the starting instructions in the engine operator's manual.

### Operating snow thrower

- Loosen hand knobs on two sides and adjust the upper discharge chute up or down as shown in Figure 10. Then use the chute crank to position the entire discharge chute in order to discharge snow with the wind.

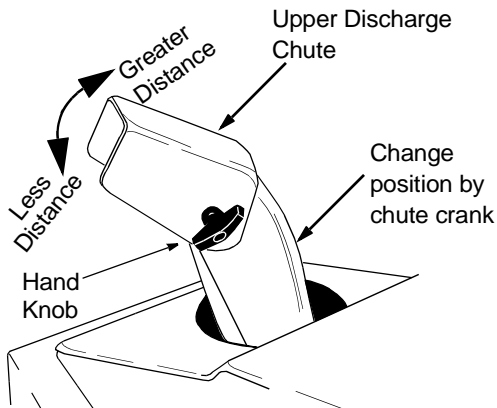

Figure 10



**WARNING:** Do not throw snow towards a building as objects could be discharged with enough force to cause damage.

- After making sure no bystanders or obstacles are in front of the unit, engage the auger control handle. See Figure 11. As the snow thrower starts to move, maintain a firm hold on the handle, and guide the snow thrower along the path to be cleared.

- Release the auger control handle to stop the snow throwing action and the forward motion.

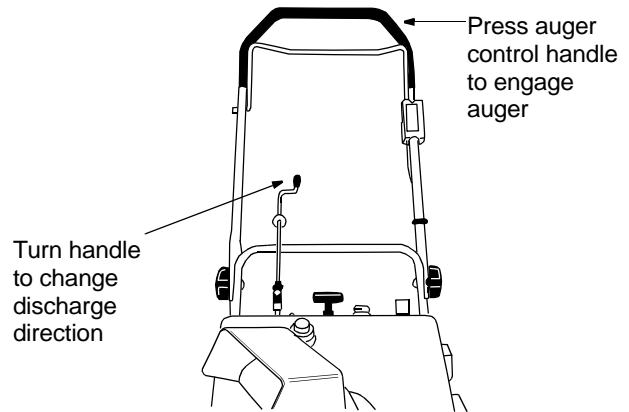

Figure 11

### Stopping engine

- Run the engine for a few minutes before stopping to help dry up any moisture on the engine.
- Turn ignition key to OFF position and remove it from the snow thrower.

**IMPORTANT:** Keep the ignition key in a safe place. Engine will not start without it.

- Wipe all snow and moisture from the unit. Move the choke lever back and forth several times and leave it in the ON position.

### Operating tips

- For most efficient snow removal, remove snow immediately after it falls.
- Discharge snow downwind whenever possible. Slightly overlap each previously cleared path.
- Lifting up on the handle will allow the rubber on the augers to propel the snow thrower forward. Pushing downward on the handle will raise the augers off the ground and stop the forward motion.

**NOTE:** Excessive upward pressure on the handle will result in premature wear on the rubber auger blades which will not be covered by warranty.

- Run the engine for a few minutes before stopping to help dry any moisture on the engine.
- Clean the snow thrower thoroughly after each use.



**WARNING:** Do not operate this snow thrower on gravel as loose gravel can easily be picked up and thrown by the auger, causing injury to people around and/or damage to the snow thrower.



## SECTION 5: MAKING ADJUSTMENTS



**WARNING: NEVER attempt to clean chute or make any adjustments or repairs while the engine is running.**

### Shave plate

- To check the adjustment of the shave plate, place the unit on a level surface. See Figure 12. The wheels, shave plate and augers should all contact the level surface. Note that if the shave plate is adjusted too high, snow may blow under the housing. If the shave plate wears excessively, or the unit will not self-propel, the shave plate may be adjusted too low.

**NOTE:** On new units or units with a new shave plate installed, the augers may be slightly off the ground.

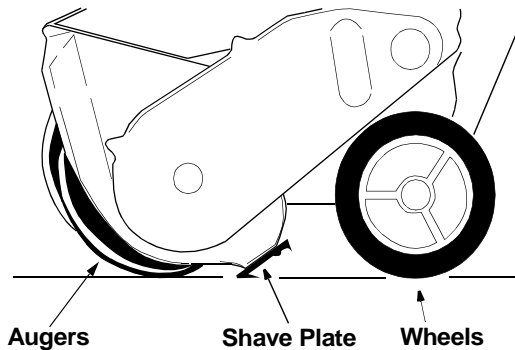

Figure 12

- To adjust, tip the snow thrower back so that it rests on the handle. Loosen the lock nuts and bolts which secure the shave plate to the housing. See Figure 13. Move the shave plate to desired position and retighten the nuts and bolts. Make certain all nuts and bolts are tightened securely.

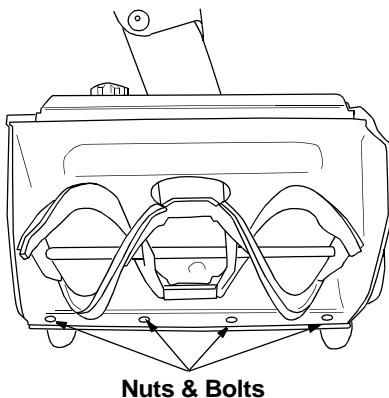

Figure 13

### Belt tension

Periodic adjustment of the belt tension may be required due to normal stretch and wear on the belt. Adjust the belt tension, following instructions below, if the augers seem to hesitate while turning although engine maintains the same speed.

- The upper hole in the control handle provides adjustment for belt tension. To adjust, disconnect the "Z" end of control cable from the bottom hole in the control handle. See Figure 14. Hook the cable into the upper hole in control handle as shown.

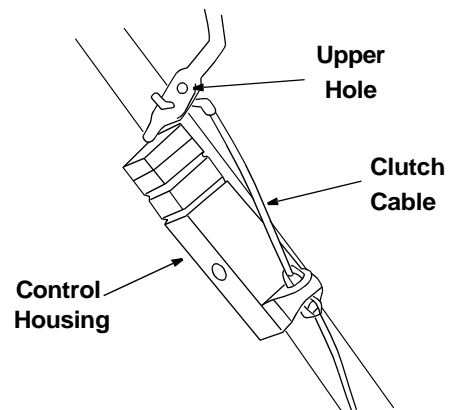

Figure 14

If additional adjustment is required, adjust the other end of the control cable at the idler bracket as described below.

- Remove the belt cover by removing five hex screws that hold it in place. See Figure 16.
- There are three adjustment holes provided in the idler bracket assembly. See Figure 15. To adjust, move the extension spring on the end of the clutch cable to the next higher adjustment position on the idler bracket assembly. Reassemble belt cover.

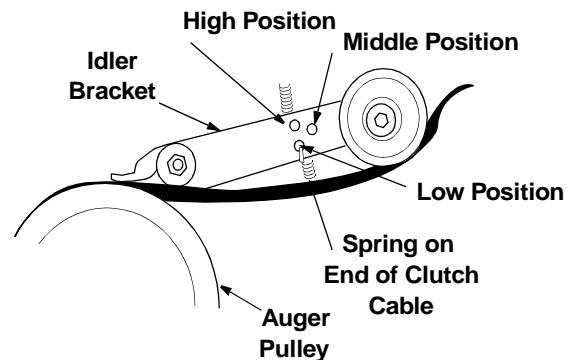

Figure 15

## SECTION 6: SERVICE



**WARNING:** Do not attempt to clean chute or make any adjustments or repairs while the engine is running.

### Engine

- Refer to the separate engine operator's manual packed with your snow thrower for all engine maintenance procedures.

### Fasteners

- Check engine and snow thrower frequently for loose nuts, bolts, etc., and keep these items tightened.

### Replacing belt

- Remove the belt cover by removing five hex screws. See Figure 16.

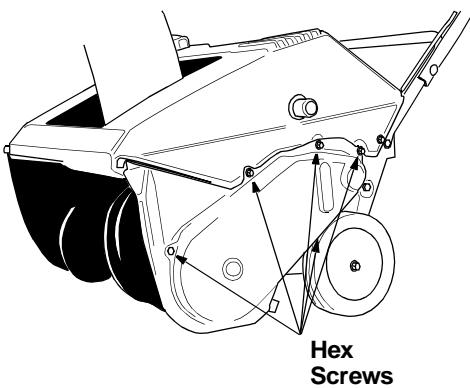

**Figure 16**

- Pull up on the idler pulley and slip the belt off the engine pulley.
- Push down on the idler pulley and slip the belt off the auger pulley.
- Reassemble new belt in reverse order.
- Reinstall the belt cover.

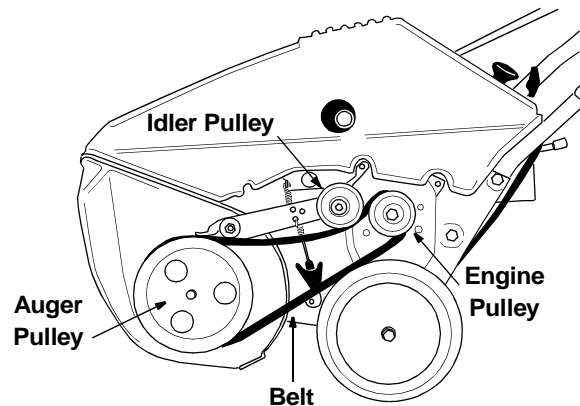
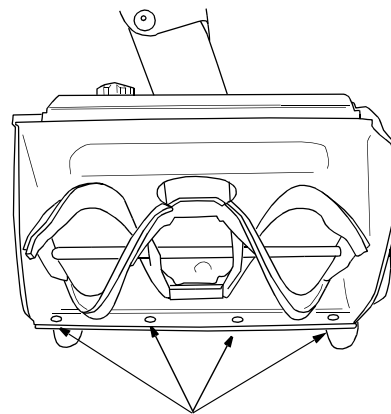

**Figure 17**

### Replacing shave plate

The shave plate is subject to wear. It should be checked periodically. There are two wearing edges and the shave plate can be reversed. See Figure 18 .

- Remove the four carriage bolts and hex lock nuts which attach it to the snow thrower housing.
- Install new shave plate, making sure the heads of the carriage bolts are on the inside of the housing.
- Adjust the shave plate according to procedure in the "Making Adjustments" section of this manual.
- Tighten securely.



**Nuts & Bolts**

**Figure 18**

## SECTION 7: MAINTENANCE

### General Recommendations

- Always observe safety rules when performing any maintenance.
- The warranty on this snow thrower does not cover items that have been subjected to operator abuse or negligence. To receive full value from the warranty, operator must maintain the snow thrower as instructed in this manual.
- Changing of engine governed speed will void engine warranty.
- Some adjustments will have to be made periodically to maintain your unit properly. All adjustments in the Making Adjustments section of this manual should be checked at least once each season.

- Periodically check all fasteners and make sure these are tight
- Follow the maintenance schedule given below to get quality performance from your snow thrower for a long time.

### Lubrication

- Lubricate pivot points on the control handle and the extension spring at the end of the clutch cable with a light oil once every season and before storage of the snow thrower at the end of the season.

### Customer Responsibilities

MAINTENANCE SCHEDULE		Before each use	After each use	Every 25 hours	Once a season	Before storage	SERVICE DATES						
PRODUCT	Lubricate pivot points				✓	✓							
	Clean snow thrower		✓			✓							
	Check shave plate adjustment	✓											
	Check belt			✓									
ENGINE	Clean engine		✓										
	Check spark plug			✓	✓								

## SECTION 8: OFF-SEASON STORAGE



**WARNING:** Never store engine with fuel in tank indoors or in enclosed, poorly ventilated areas where fuel fumes may reach an open flame, spark or pilot light as on a furnace, water heater, clothes dryer, or other gas appliance.

- Clean snow thrower thoroughly.
- Lubricate as instructed above with a light oil.
- Follow "Storage" instructions found in the separate

Engine Operator's Manual. Preparing the engine for storage properly is important to prevent problems next season.

- Store in a clean, dry area. Block the snow thrower up so it is not resting on the rubber auger blades.

**NOTE:** When storing any type of power equipment in an poorly ventilated or metal storage shed, care should be taken to rustproof the equipment, especially springs, cables and all moving parts.

## SECTION 9: TROUBLESHOOTING GUIDE

Problem	Cause	Remedy
Engine fails to start	<ol style="list-style-type: none"> <li>1. Fuel tank empty, or stale fuel</li> <li>2. Blocked fuel line</li> <li>3. Key not in ON position</li> <li>4. Spark plug wire disconnected</li> <li>5. Faulty spark plug</li> <li>6. Gasoline and oil not mixed correctly</li> </ol>	<ol style="list-style-type: none"> <li>1. Fill tank with clean fresh gasoline/oil mixture as specified in the engine manual.</li> <li>2. Clean fuel line</li> <li>3. Insert key and turn to ON position</li> <li>4. Connect wire to spark plug.</li> <li>5. Clean spark plug, readjust gap, or replace.</li> <li>6. Refer to instructions on fuel mixture in the engine manual and mix appropriately.</li> </ol>
Engine runs erratic	<ol style="list-style-type: none"> <li>1. Unit running on choke</li> <li>2. Fuel line blocked, or stale fuel</li> <li>3. Water or dirt in fuel system</li> <li>4. Carburetor out of adjustment</li> </ol>	<ol style="list-style-type: none"> <li>1. Move choke lever to OFF position.</li> <li>2. Clean fuel line and fill tank with fresh, clean gasoline.</li> <li>3. Refer to engine manual on remedy.</li> <li>4. Refer to engine manual; get the carburetor adjusted by an authorized service dealer.</li> </ol>
Engine overheats	<ol style="list-style-type: none"> <li>1. Gasoline and oil not mixed correctly</li> <li>2. Carburetor out of adjustment</li> </ol>	<ol style="list-style-type: none"> <li>1. Drain fuel tank and refill with proper fuel mixture.</li> <li>2. Refer to engine manual; get the carburetor adjusted by an authorized service dealer.</li> </ol>
Loss of power	<ol style="list-style-type: none"> <li>1. Spark plug wire loose</li> <li>2. Vent in gas cap plugged</li> <li>3. Exhaust port plugged.</li> </ol>	<ol style="list-style-type: none"> <li>1. Connect and tighten spark plug wire.</li> <li>2. Clear vent.</li> <li>3. Clean port.</li> </ol>
Excessive vibration	<ol style="list-style-type: none"> <li>1. Loose parts or damaged auger</li> </ol>	<ol style="list-style-type: none"> <li>1. Stop engine immediately and disconnect spark plug wire. Check for possible damage. Tighten all bolts and nuts. Repair as needed. If the problem persists, contact White Outdoor dealer.</li> </ol>
Unit fails to propel itself	<ol style="list-style-type: none"> <li>1. Drive cable out of adjustment</li> <li>2. Drive belt loose or damaged</li> </ol>	<ol style="list-style-type: none"> <li>1. Adjust drive cable following instructions on snow thrower.</li> <li>2. Replace drive cable following instructions on snow thrower.</li> </ol>
Unit fails to discharge snow	<ol style="list-style-type: none"> <li>1. Discharge chute clogged</li> <li>2. Foreign object lodged in auger</li> <li>3. Drive cable not adjusted properly</li> <li>4. Drive belt loose or damaged</li> </ol>	<ol style="list-style-type: none"> <li>1. Stop engine immediately and disconnect spark plug wire. Clean discharge chute and the auger housing.</li> <li>2. Stop engine immediately and disconnect spark plug wire. Remove object from auger.</li> <li>3. Adjust drive cable following instructions on snow thrower.</li> <li>4. Replace drive belt following instructions on snow thrower.</li> </ol>

**NOTE:** For repairs beyond the minor adjustments listed above, call the Customer Dealer Line at 1-800-949-4483 for the dealer nearest you. Refer to separate engine manual, packed with your snow thrower, for engine information.

# SECTION 10: PARTS LIST FOR MODEL SB45 & SB55

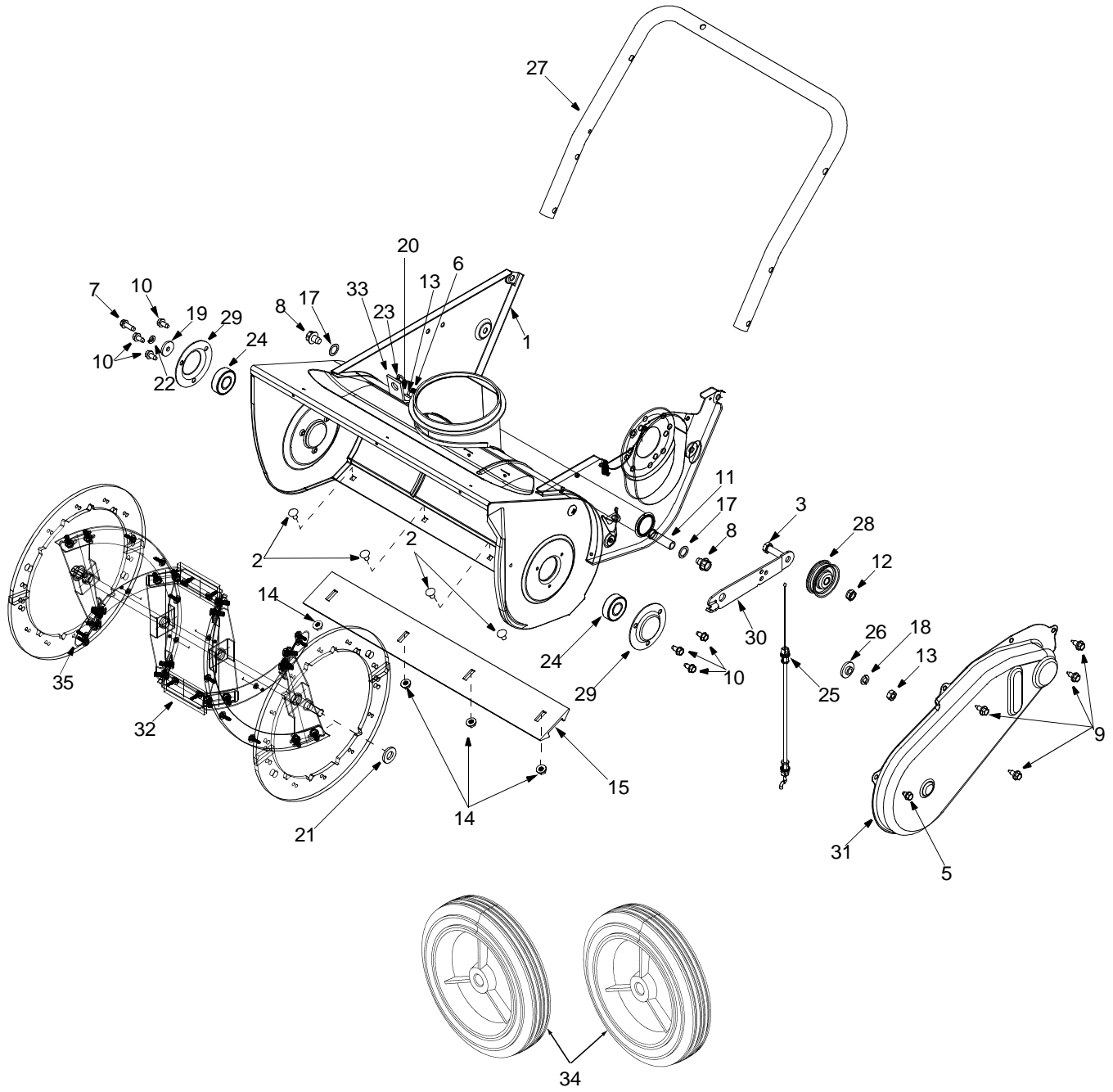

## Model SB45 & SB55

Ref. No.	Part No.	Part Description	Ref. No.	Part No.	Part Description
1.	684-0114	Auger Housing Assembly	18.	736-0119	Lock Washer
2.	710-0167	Carriage Screw 1/4-20 x 0.5"	19.	736-0176	Flat Washer
3.	710-0191	Special Screw 3/8-24 x 1.25" Gr.8	20.	736-0242	Belleville Washer
4.	710-0323	Truss Mach. Screw 5/16-18 x 0.75"	21.	736-0326	Flat Washer
5.	710-0352	Hex Screw 1/4-14 x 0.375"	22.	736-0329	Lock Washer
6.	710-0451	Carriage Bolt 5/16-18 x 0.75"	23.	741-0475	Bushing
7.	710-0642	Hex TT Screw 1/4-20 x 0.75"	24.	741-0600	Ball Bearing
8.	710-0773	Hex TT Screw 3/8-16 x 0.5"	25.	746-0910A	Clutch Cable
9.	710-0896	AB Screw 1/4-14 x 0.625"	26.	748-0234	Spacer
10.	710-1005	B Screw 1/4-14 x 0.5"	27.	749-0796	Lower Handle
11.	711-0848A	Axle Tube	28.	756-0313	Idler: Flat
12.	712-0116	Jam Nut	29.	784-5174	Bearing Cup
13.	712-3010	Hex Nut	30.	784-5175B	Idler Bracket: Brake
14.	712-3027	Hex Flange Lock Nut	31.	784-5176	Belt Cover
15.	731-1033	Shave Plate	32.	784-5485	Auger Assembly
16.	732-0357A	Extension Spring	33.	784-5720	Bracket: Chute Crank
17.	736-0108	Flat Washer	34.	734-1797	Wheel Assembly: Grey
			35.	753-0613	Auger Rubber Replacement

# Model SB45 & SB55

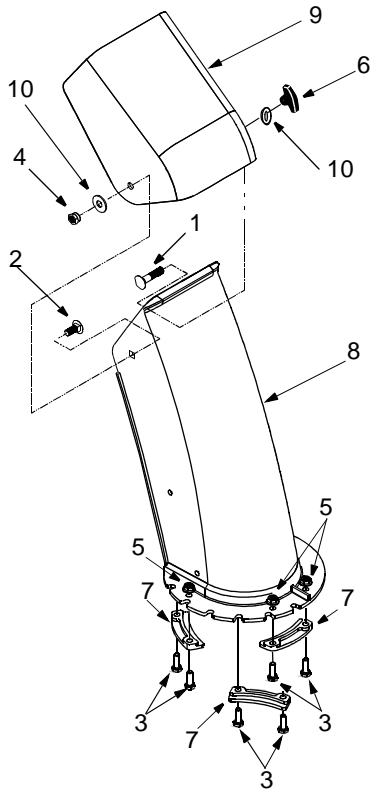

Ref. No.	Part No.	Part Description
1.	710-0276	Carriage Screw 5/16-18 x 1.0"
2.	710-0451	Carriage Bolt 5/16-18 x 0.75"
3.	710-3015	Hex Screw 1/4-20 x 0.75"
4.	712-0429	Hex Lock Nut
5.	712-3027	Flanged Lock Nut
6.	720-0284	Knob
7.	731-0851A	Chute Flange Keeper
8.	731-0915B	Lower Chute
9.	731-0921	Upper Chute
10.	736-0159	Washer

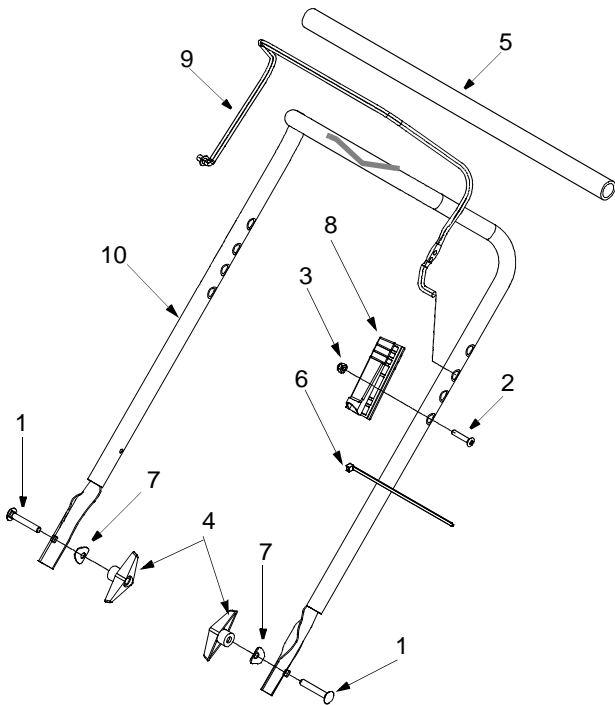

Ref. No.	Part No.	Description
1.	710-0487	Carriage Screw 5/16-18 x 2.0
2.	710-1270	Oval C-Sunk Screw 1/4-20 x 1.31
3.	712-0324	Hex Lock Nut 1/4-20
4.	720-0284	Handle Knob
5.	720-0295	Foam Grip: Handle
6.	725-0157	Cable Tie
7.	736-0451	Saddle Washer
8.	746-0883	Cable Housing
9.	747-0956	Auger Handle: Gull Wing
10.	749-0711A	Upper Handle: Gull Wing

# Model SB45 & SB55

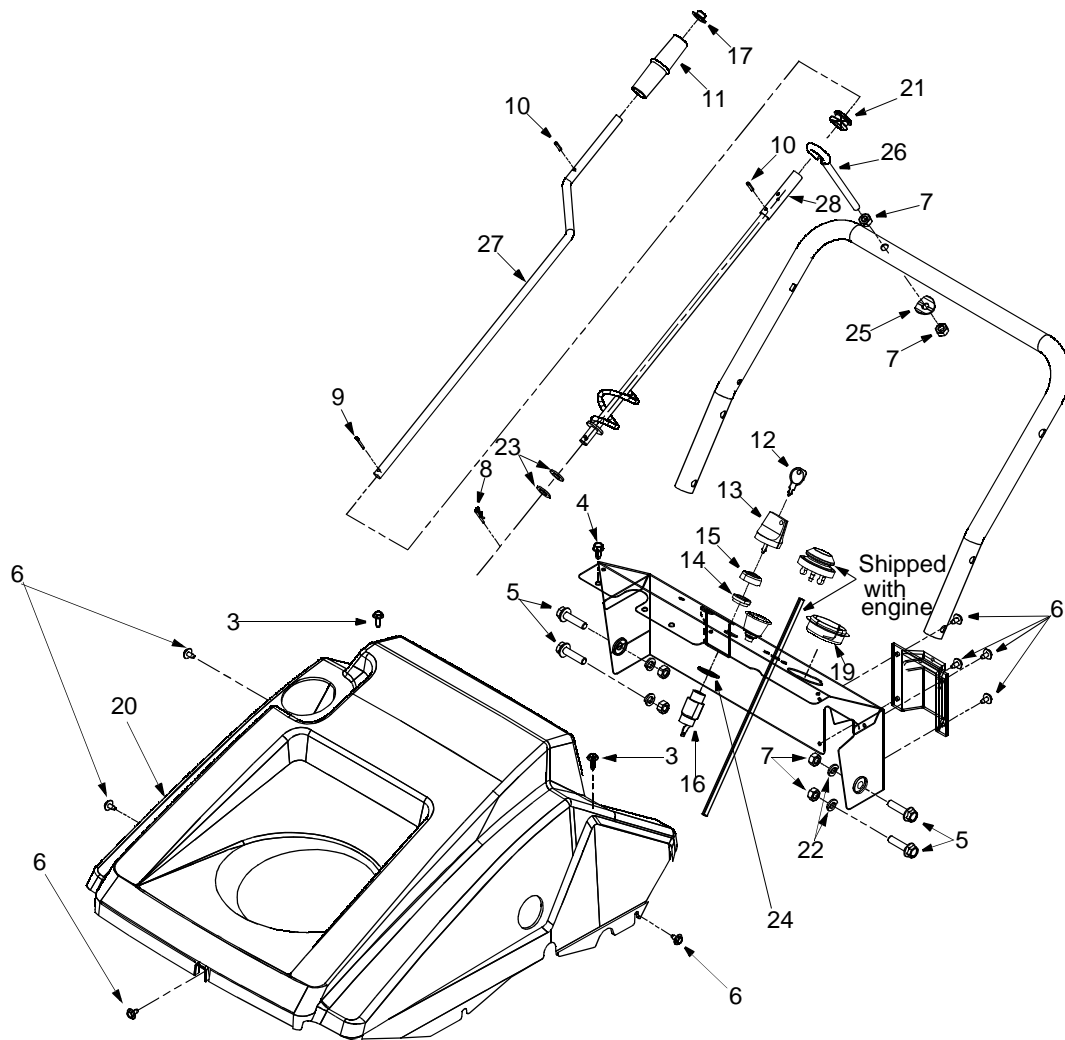

Ref. No.	Part No.	Part Description	Ref. No.	Part No.	Part Description
1.	684-0054	Dash: 21" Mitten Panel Assy.	15.	725-1347	Ignition Switch Cap
2.	684-0126	Chute Crank Assembly	16.	725-1425	Switch: Key Recoil Start
3.	710-1003	Special Screw	17.	726-0100	Push Cap
4.	710-1005	B Screw 1/4-14 x 0.5"	18.	731-1089A	Choke Cover
5.	710-1090	Hex Flange Screw	19.	731-1133B	Cap
6.	710-1268	Special Screw	20.	731-1551A	Engine Shroud: Grey
7.	712-3010	Hex Nut: 5/16-18	21.	735-0234	Rubber Grommet
8.	714-0104	Cotter Pin	22.	736-0119	Lock Washer
9.	714-0507	Cotter Pin	23.	736-0185	Flat Washer
10.	715-0138	Roll Pin	24.	736-0225	Internal Lock Washer
11.	720-0201A	Chute Crank Knob	25.	736-0451	Saddle Washer
12.	725-0201	Ignition Key	26.	747-0697	Eye Bolt
13.	725-1341B	Ignition Key w/o Logo	27.	747-0737	Chute Crank: Upper
14.	725-1346	Ignition Switch Nut	28.	750-0785	Spacer



# Model SB45 & SB55

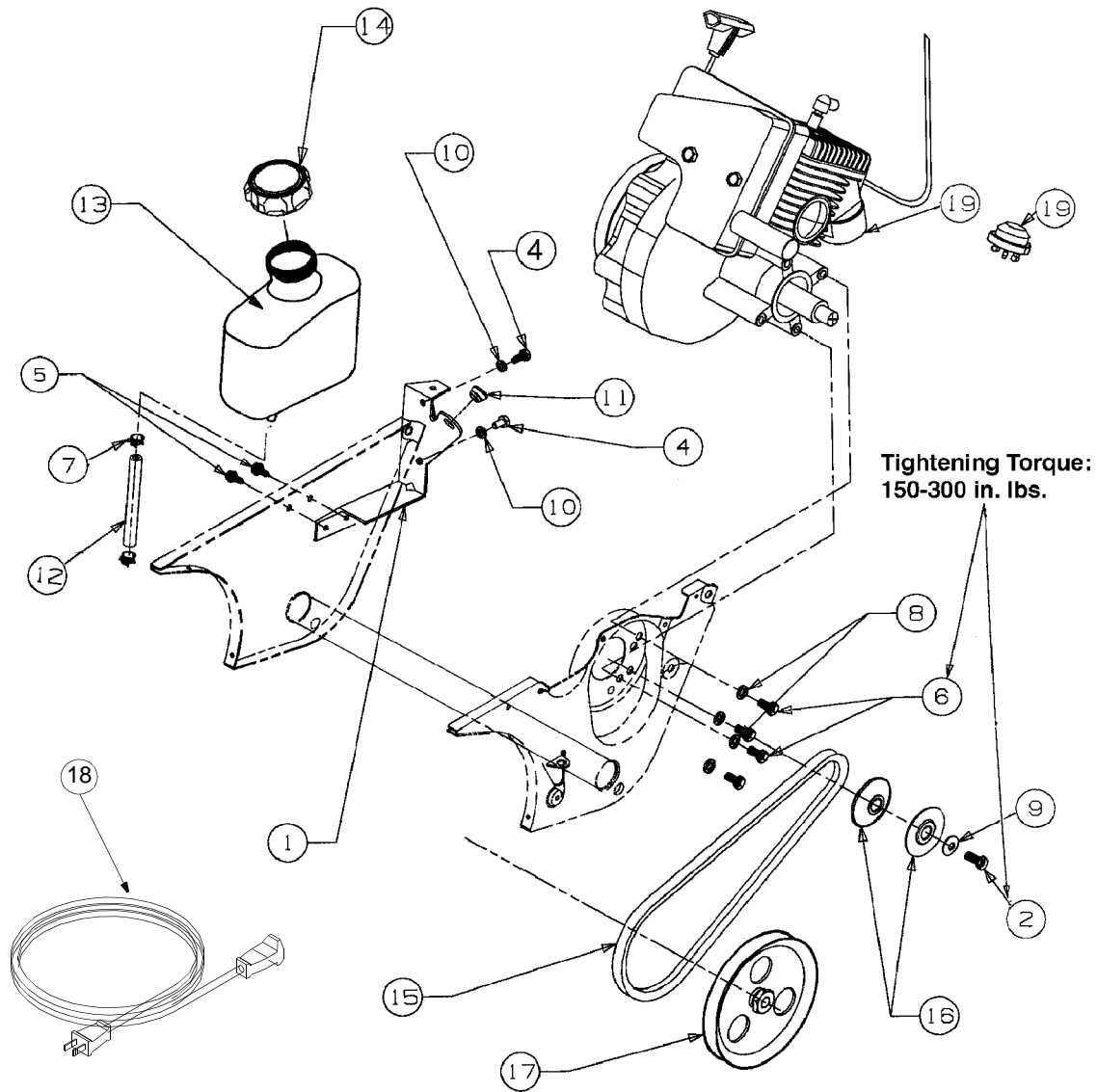

Ref. No.	Part No.	Part Description	Ref. No.	Part No.	Part Description
1.	705-5139	Support Bracket, Gas Tank	12.	751-0535-16	Hose, Fuel Line—16"
2.	710-0157	Hex Cap Screw 5/16-24 x 0.75"	13.	751-0540A	Fuel Tank—2 qt.
4.	710-3013	Hex Screw 1/4-20 x 0.50"	14.	751-0800	Fuel Cap
5.	710-0896	Washer Screw 1/4-14 x 0.625"	15.	754-0101A	V-Belt
6.	710-3025	Hex Cap Screw 5/16-24 x 0.625"	16.	756-0416B	V-Pulley Half
7.	726-0205	Hose Clamp	17.	756-0475	V-Pulley Half
8.	736-0119	Lock Washer	18.	629-0236	Cord, Extension
9.	736-0242	Bell Washer	19.	—	Obtain from engine manufacturer
10.	736-0329	Lock Washer			
11.	741-0475	Plastic Bushing			

Your Notes	Dates

Your Notes	Dates

# MANUFACTURER'S LIMITED WARRANTY FOR:



The limited warranty set forth below is given by White Outdoor Products Co. with respect to new merchandise purchased and used in the United States, its possessions and territories.

White Outdoor Products Co. warrants this product against defects in material and workmanship for a period of two (2) years commencing on the date of original purchase and will, at its option, repair or replace, free of charge, any part found to be defective in material or workmanship. This limited warranty shall only apply if this product has been operated and maintained in accordance with the Operator's Manual furnished with the product, and has not been subject to misuse, abuse, commercial use, neglect, accident, improper maintenance, alteration, vandalism, theft, fire, water or damage because of other peril or natural disaster. Damage resulting from the installation or use of any accessory or attachment not approved by White Outdoor Products Co. for use with the product(s) covered by this manual will void your warranty as to any resulting damages.

Normal wear parts or components thereof are subject to separate terms as follows: All normal wear part or component failures will be covered on the product for a period of 90 days regardless of cause. After 90 days, but within the two year period, normal wear part failures will be covered ONLY IF caused by defects in material or workmanship of OTHER component parts. Normal wear parts and components include, but are not limited to, belts, blades, blade adapters, grass bags, rider deck wheels, seats, snow thrower skid shoes, shave plates and tires. Batteries are covered by a 90-day limited replacement warranty.

**HOW TO OBTAIN SERVICE:** Warranty service is available, WITH PROOF OF PURCHASE THROUGH YOUR LOCAL WHITE OUTDOOR DEALER. To locate the dealer in your area, please check for a listing in the Yellow Pages or contact the Customer Dealer Referral Line of White Outdoor Co. by calling 1-330-225-8883 or writing to P.O. Box 361131, Cleveland, Ohio 44136-0019. No product returned directly to the factory will be accepted unless prior written permission has been extended by White Outdoor Co.

**This limited warranty does not provide coverage in the following cases:**

- a. The engine or component parts thereof. These items carry a separate manufacturer's warranty. Please refer to the applicable manufacturer's warranty on these items.
- b. Log splitter pumps, valves and cylinders have a separate one year warranty.

c. Routine maintenance items such as lubricants, filters, blade sharpening and tune-ups, or adjustments such as brake adjustments, clutch adjustments or deck adjustments; and normal deterioration of the exterior finish due to use or exposure.

d. White Outdoor Co. does not extend any warranty for products sold or exported outside of the United States of America, its possessions and territories, except those sold through White Outdoor Co. authorized channels of export distribution.

**No implied warranty, including any implied warranty of merchantability or fitness for a particular purpose, applies after the applicable period of express written warranty above as to the parts as identified. No other express warranty or guaranty, whether written or oral, except as mentioned above, given by any person or entity, including a dealer or retailer, with respect to any product shall bind White Outdoor Co. During the period of the Warranty, the exclusive remedy is repair or replacement of the product as set forth above.** (Some states do not allow limitations on how long an implied warranty lasts, so the above limitation may not apply to you.)

**The provisions as set forth in this Warranty provide the sole and exclusive remedy arising from the sales. White Outdoor Co. shall not be liable for incidental or consequential loss or damages including, without limitation, expenses incurred for substitute or replacement lawn care services, for transportation or for related expenses, or for rental expenses to temporarily replace a warranted product.** (Some states do not allow the exclusion or limitation of incidental or consequential damages, so the above exclusion or limitation may not apply to you.)

In no event shall recovery of any kind be greater than the amount of the purchase price of the product sold. Alteration of the safety features of the product shall void this Warranty. You assume the risk and liability for loss, damage, or injury to you and your property and/or to others and their property arising out of the use or misuse or inability to use the product.

This limited warranty shall not extend to anyone other than the original purchaser, original lessee or the person for whom it was purchased as a gift.

**How State Law Relates to this Warranty:** This limited warranty gives you specific legal rights, and you may also have other rights which vary from state to state.