

SUBMITTAL SHEET



SYSTEM INDOOR/OUTDOOR

36TS32A TS3632/C3632A

CEILING SUSPENDED AIR CONDITIONER

SS36TS32A-2

GENERAL DATA		(AT 230V)
POWER V/PH/Hz	230/208/1/60	
Circuit Ampacity, Min. (A)	35	
Fuse size, Max. (A)	35	
COMPRESSOR	Rotary-Hermetic	
No. used	1	
R.L. Amps - L.R. Amps (A)	12.5 ñ 95.0	
Crankcase Heater	30W	
OUTDOOR FAN - TYPE	Propeller	
Dia. (in.) - No. used	18-3/32 - 2	
Type Drive - No. speeds	Direct ñ 3 (AUTO)	
No. Poles - RPM (High)	6 - 879	
No. Motors ñ HP	2 - 110	
CFM (High)	3,670	
F.L. Amps. (A)	1.8	
OUTDOOR COIL - TYPE	Aluminum Fin & Copper Pipe	
Fin Type - Pipe Type	Slit Plate - Inner Riffled	
Rows - F.P.I.	2 - 12.7	
Face Area (sq.ft.)	11.63	
Tube Size (in.)	3/8	
INDOOR FAN - TYPE	Cross - Flow	
Dia. (in.) - No. used	5-29/32 & 39-4	
No. speeds	3 & Auto	
No. Poles -RPM (High)	4 - 1,015	
No. Motors ñ HP	1 - 100	
CFM (HI/MED/LOW)	900/790/680	
F.L. Amps (A)	0.7	
INDOOR COIL ñ TYPE	Aluminum Fin & Copper Pipe	
Fin Type - Pipe type	Slit Plate - Inner Riffled	
Rows - F.P.I.	2 - 12.7	
Face Area (sq. ft.)	3.51	
Tube Size (in.)	5/16	
Drain Connection Size (in.)	1-1/4	
REFRIGERANT	R22	
Lbs. - R22 (O.D. Unit)	9.48	
Control	Capillary Tube	
Connection	Flare	
Line Length, Max (ft.)	165	
Lift difference, Max (ft.)	100	
Line Size - in. O.D. Discharge	3/8	
Line Size - in. O.D. Suction	3/4	
DIMENSIONS (in.)	H	x W x D
Indoor Unit -Uncrated	9-7/16	x 62 x 26-3/8
-Crated	12	x 65-20/32 x 29-3/4
Outdoor Unit -Uncrated	48-5/8	x 37 x 13-3/8
-Crated	52ñ7/32	x 40 x 16-12/32
WEIGHT	INDOOR	OUTDOOR
Net (lbs.)	84.0	198.0
Shipping(lbs.)	97.0	223.0
Shipping Volume (cu.ft.)	13.6	19.8

PERFORMANCE DATA @ ARI STANDARD CONDITIONS (230/208V)

COOLING		
Total Capacity	(BTU/H)	34,800/33,000
Sensible Capacity	(BTU/H)	22,320/21,700
Latent Capacity	(BTU/H)	11,680/11,300
SEER		10.6/10.9
Dehumidification	(Pints/H)	10.6/10.8
Amps	(A)	15.0/15.5
Power Inputs	(W)	3,340/3,130
Outdoor Sound Rating	(bels)	7.9

FEATURE

Controls	Microprocessor
Remote Controller	LCD Wireless type
Temperature Control	IC Thermostat
Timer	ON/OFF, 24 hours
Night-Setback	Built-In
Air Louver (Horizontal)	Manual
(Vertical)	Automatic
Power Failure Automatic Restart	Built-In
Self Diagnosis	N/A

OPTION

Refrigerant Line Set	AP3210BH (30 ft)	AP3215BH (50 ft)
Low Ambient Control	Available	
Fresh Air Intake	Available	
Central Remote ON-OFF Control	Available	
Airduct Extension	N/A	
Indoor Frame Extension	N/A	
Condensate Drain Pump	Available	
Non-Removable Remo-con Bracket	Available	

OPERATING RANGE

Cooling	Indoor Air Intake Temp.		Outdoor Air Intake Temp.
	Maximum	95 F DB/71 F WB	
Minimum	67 F DB/57 F WB		67 F DB

CERTIFICATION



SUBMITTAL SHEET



AIRCONDITIONING PRODUCTS

SYSTEM INDOOR/OUTDOOR
36TLS32A TS3632/CL3632A
 CEILING SUSPENDED LOW AMBIENT AIR CONDITIONER

SS36TLS32A-2

GENERAL DATA (AT 230V)

POWER V/PH/Hz	230/208/1/60
Circuit Ampacity, Min. (A)	35
Fuse size, Max. (A)	35

COMPRESSOR	Rotary-Hermetic
No. used	1
R.L. Amps - L.R. Amps (A)	12.5 ñ 95.0
Crankcase Heater	30W

OUTDOOR FAN - TYPE	Propeller
Dia. (in.) - No. used	18-3/32 - 2
Type Drive - No. speeds	Direct ñ 3 (AUTO)
No. Poles - RPM (High)	6 - 879
No. Motors ñ HP	2 - 110
CFM (High)	3,670
F.L. Amps. (A)	1.8

OUTDOOR COIL ñ TYPE	Aluminum Fin & Copper Pipe
Fin Type - Pipe Type	Slit Plate - Inner Riffled
Rows - F.P.I.	2 - 12.7
Face Area (sq.ft.)	11.63
Tube Size (in.)	3/8

INDOOR FAN ñ TYPE	Cross - Flow
Dia. (in.) - No. used	5-29/32 & 39-4
No. speeds	3 & Auto
No. Poles -RPM (High)	4 - 1,015
No. Motors ñ HP	1 - 100
CFM (HI/MED/LOW)	900/790/680
F.L. Amps (A)	0.7

INDOOR COIL - TYPE	Aluminum Fin & Copper Pipe
Fin Type - Pipe type	Slit Plate - Inner Riffled
Rows - F.P.I.	2 - 12.7
Face Area (sq. ft.)	3.51
Tube Size (in.)	5/16
Drain Connection Size (in.)	1-1/4

REFRIGERANT	R22
Lbs. - R22 (O.D. Unit)	9.48
Control	Capillary Tube
Connection	Flare
Line Length, Max (ft.)	165
Lift difference, Max (ft.)	100
Line Size - in. O.D. Discharge	3/8
Line Size - in. O.D. Suction	3/4

DIMENSIONS (in.)	H	x	W	x	D
Indoor Unit -Uncrated	9-7/16	x	62	x	26-3/8
-Crated	12	x	65-20/32	x	29-3/4
Outdoor Unit -Uncrated	48-5/8	x	37	x	13-3/8
-Crated	52ñ7/32	x	40	x	16-12/32

WEIGHT	INDOOR	OUTDOOR
Net (lbs.)	84.0	198.0
Shipping(lbs.)	97.0	223.0
Shipping Volume (cu.ft.)	13.6	19.8

PERFORMANCE DATA @ ARI STANDARD CONDITIONS (230/208V)

COOLING		
Total Capacity	(BTU/H)	34,800/33,000
Sensible Capacity	(BTU/H)	22,320/21,700
Latent Capacity	(BTU/H)	11,680/11,300
SEER		10.6/10.9
Dehumidification	(Pints/H)	10.6/10.8
Amps	(A)	15.0/15.5
Power Inputs	(W)	3,340/3,130
Outdoor Sound Rating	(bels)	7.9

FEATURE

Controls	Microprocessor
Remote Controller	LCD Wireless type
Temperature Control	IC Thermostat
Timer	ON/OFF, 24 hours
Night-Setback	Built-In
Air Louver (Horizontal)	Manual
(Vertical)	Automatic
Power Failure Automatic Restart	Built-In
Self Diagnosis	N/A

OPTION

Refrigerant Line Set	AP3210BH (30 ft)	AP3215BH (50 ft)
Low Ambient Control	Equipped	
Fresh Air Intake	Available	
Central Remote ON-OFF Control	Available	
Air duct Extension	N/A	
Indoor Frame Extension	N/A	
Condensate Drain Pump	Available	
Non-Removable Remo-con Bracket	Available	

OPERATING RANGE

Cooling	Indoor Air Intake Temp.	Outdoor Air Intake Temp.
Maximum	95 F DB/71 F WB	115 F DB
Minimum	67 F DB/57 F WB	0 F DB

CERTIFICATION



36TLS32A

DIMENSIONAL DATA

Indoor Unit: TS3632

Dimension : inch

- ① Drain connection
- ② Drain connection for left side
- ③ Refrigerant liquid line (3/8") Flare connection
- ④ Refrigerant gas line (3/4") Flare connection
- ⑤ Hole for rear side refrigerant tubing
- ⑥ Hole for through-the-wall refrigerant tubing (ø3-15/16" hole)
- ⑦ Hole for fresh air intake (Knockout hole)
- ⑧ Hole for right side refrigerant tubing (Knockout hole)
- ⑨ Hole for left side drain connection (Knockout hole)
- ⑩ Hole for power supply (Conduit size 1/2")
- ⑪ Infrared rays receiver for wireless remote controller
- ⑫ Cutting position for fresh air intake

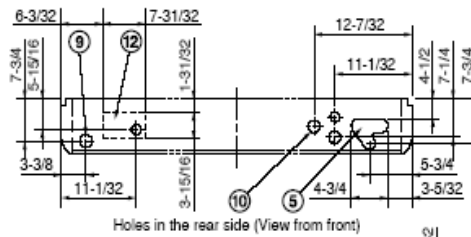

Holes in the rear side (View from front)

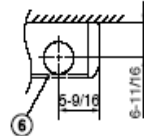

Hole for wall-through piping (View from front)

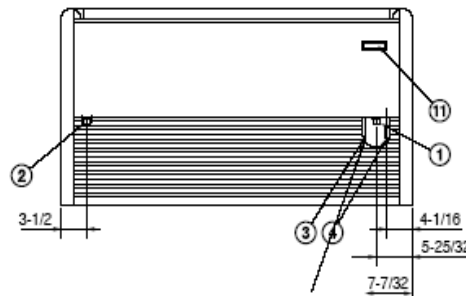
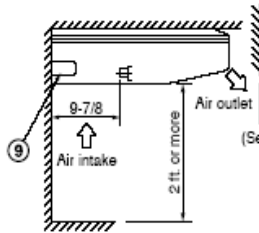
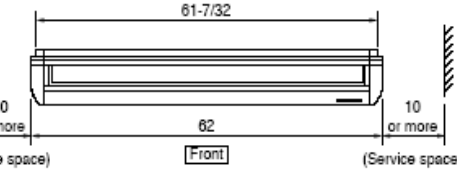
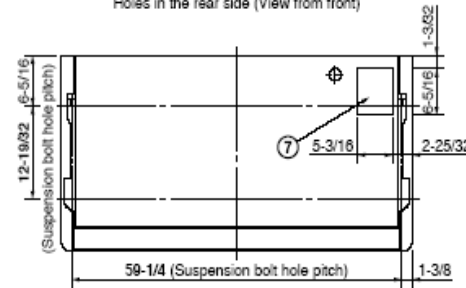

• Remote controller (Accessory)

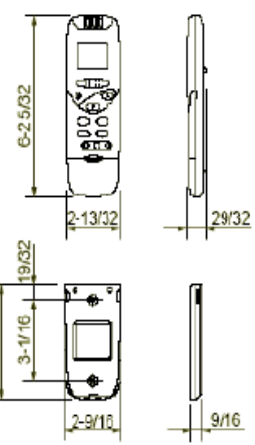

Outdoor Unit: C3632A, CL3632A

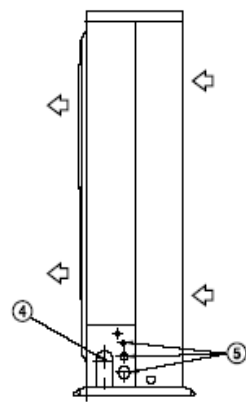
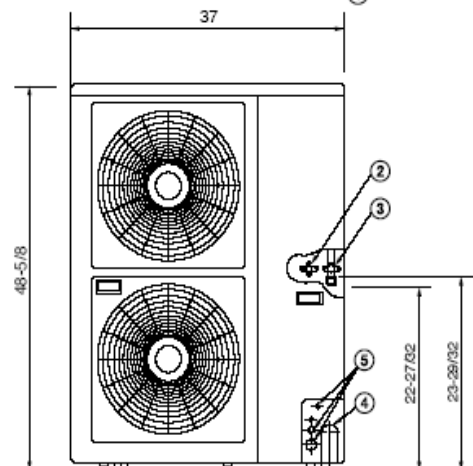
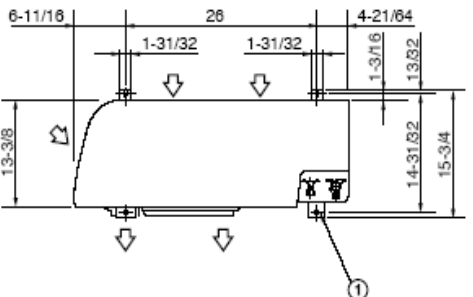

Dimension : inch

- ① Hole for anchor bolt (4-ø13)
- ② Refrigerant tube joint (narrow tube) Flare connection 3/8 in (9.52 mm)
- ③ Refrigerant tube joint (wide tube) Flare connection 3/4 in (19.05 mm)
- ④ Refrigerant tubing inlet
- ⑤ Power supply inlet

WARRANTY

SANYO products are warranted against defects in materials and workmanship for the period below:

	LABOR	PARTS
Compressor	30 Days	5 Years
Other Components	N/A	1 Year

Because of a policy of continuous product improvements, SANYO reserves the right to change specifications and design without notice.

Full specific warranty rights, conditions, exclusions and obligations are specified in the warranty packed with each product.

SANYO FISHER COMPANY
 A Division of SANYO North America Corporation
 21605 Plummer St. Chatsworth, CA 91311
 Phone : (818) 998-7322
 Fax : (818) 701-4160
 Website: <http://www.sanyohvac.com>