

# STEAM & DRY IRON

---



MODEL WST5000ZE

**OWNER'S MANUAL**



**Westinghouse**

# IMPORTANT SAFEGUARDS

When using your flat iron, basic safety precautions should always be followed including the following:

1. Read all instructions.
2. Use iron only for its intended use.
3. To protect against a risk of electric shock, do not immerse the iron in water or other liquids.
4. The iron should always be turned to off before plugging or unplugging from outlet. Never yank cord to disconnect from outlet; instead, grasp plug and pull to disconnect.
5. Do not allow cord to touch hot surfaces. Let iron cool completely before putting away. Loop cord loosely around iron when storing.
6. Always disconnect iron from electrical outlet when filling with water or emptying and when not in use.
7. Do not operate iron with a damaged cord or if the iron has been dropped or damaged. To avoid the risk of electric shock, do not disassemble the iron. Incorrect reassembly can cause a risk of electric shock when the iron is used. Contact Consumer Service for examination and repair.
8. Close supervision is necessary for any appliance being used by or near children. Do not leave iron unattended while connected or on an ironing board.
9. Burns can occur from touching hot metal parts, hot water, or steam. Use caution when you turn a steam iron upside down---there may be hot water in the reservoir.

## SPECIAL INSTRUCTIONS

1. To avoid a circuit overload, do not operate another high wattage appliance on the same circuit.
2. If an extension cord is absolutely necessary, a 15-ampere cord should be used. Cords rated for less amperage may overheat. Care should be taken to arrange the cord so that it cannot be pulled or tripped over.

# SAVE THESE INSTRUCTIONS

**For Household Use Only**

# ADDITIONAL IMPORTANT SAFEGUARDS

**CAUTION HOT SURFACES:** This appliance generates heat and escaping steam during use. Proper precautions must be taken to prevent the risk of burns, fires or other damage to persons or property.

1. All users of this appliance must read and understand this Owner's Manual before operating or cleaning this appliance.
2. The cord to this appliance should be plugged into a 120V AC electrical outlet only.
3. If this appliance begins to malfunction during use, immediately unplug the cord. Do not use or attempt to repair the malfunctioning appliance.
4. Do not leave this appliance unattended during use.

## POLARIZED PLUG

This appliance has a polarized plug (one blade is wider than the other). To reduce the risk of electric shock, this plug is intended to fit into a polarized outlet only one way. If the plug does not fit fully in the outlet, reverse the plug. If it still does not fit, contact a qualified electrician. Do not attempt to modify the plug in any way.

## ELECTRIC POWER

If the electrical circuit is overloaded with other appliances, your appliance may not operate properly. It should be operated on a separate electrical circuit from other appliances.

# GETTING TO KNOW YOUR WESTINGHOUSE WST5000ZE STEAM & DRY IRON

PRODUCT MAY VARY SLIGHTLY FROM ILLUSTRATION.

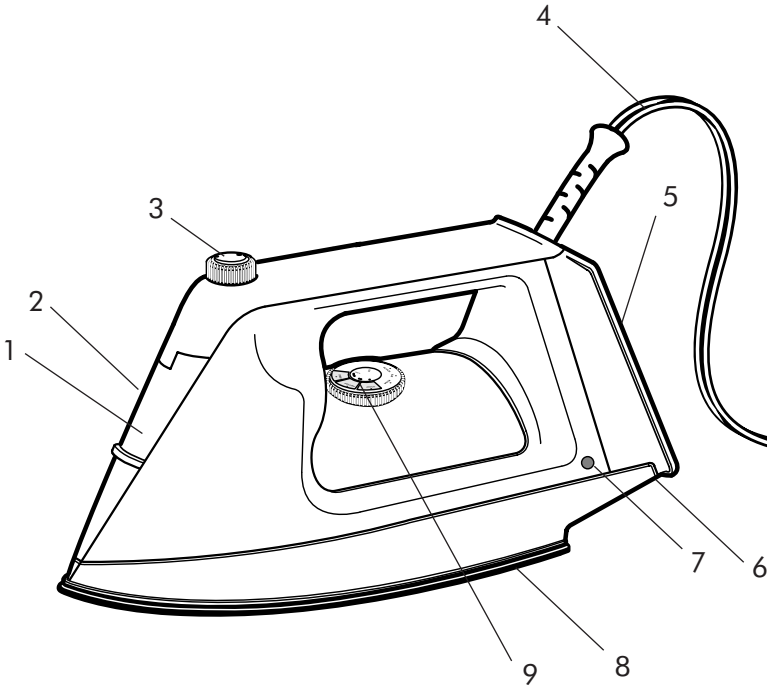

- 1. Water Fill Port Cover
- 2. Water Fill Port
- 3. Adjustable Steam Dial
- 4. Swivel Cord
- 5. Heel Rest

- 6. Cord Winder
- 7. Red Indicator Light
- 8. Soleplate
- 9. Temperature Dial

# FEATURES

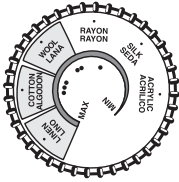

## TEMPERATURE DIAL

Select temperatures based on the type of fabric to be ironed.



## ADJUSTABLE STEAM DIAL

For selecting dry ironing, turn to OFF. 

For steam ironing, adjust dial to preferred steam position.

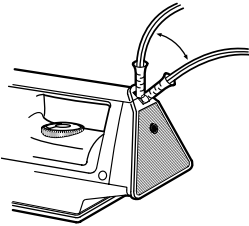

## SWIVEL CORD FOR LEFT- AND RIGHT-HANDED USERS

Pivots up and down and is supported to prevent dragging along the fabric. The flexible grommet protects the cord from fraying.

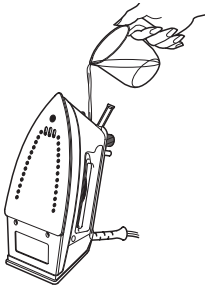

## WATER FILL PORT

Easy to fill for using steam feature.

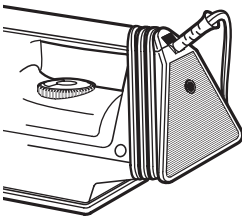

## CORD WINDER

Holds cord conveniently and safely when iron is stored.

## BEFORE USING FOR THE FIRST TIME

Carefully unpack your Iron and remove all packaging materials and any adhesive stickers from the Soleplate. Make sure all adhesive is removed by rubbing Soleplate with a damp cloth. To remove any dust that may have accumulated on the Iron during packaging, simply wipe with a clean, damp cloth. Do not use abrasive cleansers. Do not put the Iron, cord or plug in water.

**NOTE: Before you use your Iron for the first time, you should flush the Soleplate steam vents to ensure that no stain is transferred onto fabric from residue possibly left in the vents from the manufacturing process.** To do this, see USER MAINTENANCE INSTRUCTIONS - **"CLEANING SOLEPLATES HOLES"**, p.13

1. For best results, check garment labels for the temperature and steam setting recommended by the fabric manufacturer.
2. To prevent damaging garments from too hot of an Iron, it is best to first Iron garments that require low temperature. If you should need to switch from a high setting to a lower temperature, for example LINEN to NYLON, allow the Iron about 5 minutes to reach the lower temperature.

## TIPS

If you are unsure of a garment's fabric content, start on a low setting and test the Iron on an area of the garment that does not show, such as a seam. Gradually increase the heat setting until wrinkles remove without damaging the fabric. To freshen up garments made of velvet, felt, suede or velour, hold the steaming Iron horizontally 2 inches above the fabric for a gentle steaming. Make sure the Iron does not come in contact with the fabric. To prevent shine, iron dark garments or those made of silk, acetate or rayon inside out.

**CAUTION: To prevent fire, do not leave Iron unattended while plugged in.**

# OPERATING INSTRUCTIONS

## DRY IRONING

The Iron can be used on the dry setting with or without water in the tank, however it is best to avoid having the tank too full of water during dry ironing.

1. Before first use, remove any adhesive stickers from the Soleplate. Make sure all adhesive is removed by rubbing Soleplate with a damp cloth.
2. With the Iron unplugged turn Steam Dial to "OFF".   
This will stop the flow of steam if water is in the Reservoir.
3. Turn Temperature Dial to "MIN" setting.
4. Plug the cord into a 120V AC electrical outlet.
5. Turn Temperature Dial to desired setting. (See "IRONING GUIDE" for detailed information.) The Red Indicator Light will turn on as soon as the Iron is plugged in and the Temperature Dial is turned to a heat setting above "MIN".

**NOTE:** When turned on for the first time, your new Iron may emit an odor for up to 10 minutes. This is due to the initial heating of the materials used in making the Iron. The odor is safe and should not reoccur after initial heating.

6. Place Iron on its Heel Rest and place on a stable, protected surface. Allow Iron to heat to selected temperature setting. When Red Indicator Light turns off, the Iron is ready for use.
7. When finished ironing, turn Temperature Dial to "MIN" and Steam Dial to "OFF". Unplug Iron from wall outlet. Allow Iron to cool completely before cleaning the exterior or storing.

**NOTE:** During ironing, the Temperature Ready Light may turn on again which indicates that the Iron is heating up to maintain the proper temperature.

**CAUTION:** If the Iron has been used for a long time and is hot. DO NOT fill it with water. Allow to cool, then refill and resume ironing.

## STEAM IRONING

**NOTE:** Due to the special Soleplate design, ordinary tap water may be used in this Iron. However, in very hard water areas, we recommend the use of distilled water or water which has been demineralized.

**WARNING: Before filling Iron with water, make sure the plug is removed from the wall socket.**

**WARNING: TO PREVENT THE RISK OF BURNS, use caution when filling Iron with water. Burns can occur from touching hot metal parts, hot water, or steam.**

# OPERATING INSTRUCTIONS (Cont.)

## STEAM IRONING (Cont.)

When using as a Steam Iron, be sure the temperature setting on the Temperature Control Dial is within the WOOL to LINEN setting to avoid water spotting on the garment.

1. Before first use, remove any adhesive stickers from the Soleplate. Make sure all adhesive is removed by rubbing Soleplate with a damp cloth.
2. Turn Steam Dial to "OFF".  This will stop the flow of steam if water is in the Reservoir.
3. Turn Temperature Dial to "MIN".
4. With the unit UNPLUGGED, lift Water Fill Port Cover and pour water through Water Fill Port to the "MAX" water level.

**CAUTION: Never fill Iron with fabric conditioner, starches, or any other solution as these will damage the steam mechanism. Do not use contaminated water.**

5. Plug the cord into a 120V AC electrical outlet.
6. Turn Temperature Dial to "WOOL", "COTTON" or "LINEN" setting. (If the temperature is set below these temperatures, steam will not be able to form properly and water may drip from the Soleplate.) The Red Indicator Light will turn on as soon as the Iron receives power and the Temperature Dial is turned to a heat setting above "MIN".

**NOTE:** When turned on for the first time, your new Iron may emit an odor for up to 10 minutes. This is due to the initial heating of the materials used in making the Iron. The odor is safe and should not reoccur after initial heating.

7. Turn Steam Dial to adjust steam rate. When using the maximum steam rate, the iron uses more water and it may be necessary to fill the Reservoir more often.
8. Place Iron on its Heel Rest and place on a stable, protected surface. Allow Iron to heat to selected temperature setting. When Red Indicator Light turns off, the Iron is ready for use.
9. When finished ironing, turn Temperature Dial to "MIN" and Steam Dial to "OFF". Unplug Iron from wall outlet. Allow Iron to cool completely before cleaning the exterior of the Iron or storing.

**CAUTION:** Avoid coming in contact with escaping steam.

**CAUTION:** If the Iron has not been used for a long period of time and is hot, DO NOT fill it with water. Allow to cool, then refill and resume ironing.



# IRONING GUIDE

## SELECTING IRON TEMPERATURES

Always read garment labels and follow the manufacturer's ironing instructions. Refer to the "Ironing Chart" on the next page for temperature recommendations:

**ACRYLIC/SILK** Use low settings for acrylic, silk and synthetics.

**RAYON/WOOL** Use moderate settings for rayon, wool, and fabrics with more than 20% rayon or wool.

**COTTON/LINEN** Use high settings for cotton, linen, and blends.

## IRONING HINTS

**Warning! To prevent fire, do not leave Iron unattended while plugged in.**

1. Sort articles to be ironed according to the type of fabric. This will reduce the need to adjust the temperature for different types of garments.
2. If you are not sure of the fiber content of a garment, test a small area such as a seam or inside hem section before ironing a visible area. Start with a low temperature setting and gradually increase to find the best setting.
3. When reducing the temperature for iron sensitive fabrics, allow approximately 2 minutes for the iron to cool to the new temperature setting.
4. Fabrics such as velour, wool, linen and silk are best ironed with an ironing cloth to prevent shine marks.

# IRONING GUIDE (Cont.)

FABRIC	TEMPERATURE SETTING	IRONING RECOMMENDATIONS
Acrylic	ACRYLIC	Dry iron inside out.
Acetate	ACRYLIC	Dry iron inside out while still damp.
Silk	SILK	Iron inside out. Use an ironing cloth to prevent shine marks.
Nylon	SILK	Iron inside out while still damp.
Polyester	SILK	Iron inside out while still damp.
Rayon	RAYON	Iron inside out.
Viscose	RAYON	Mainly dry iron. Steam can be used under manufacturer's instructions.
Wool	WOOL	Steam iron inside out or use an ironing cloth.
Wool Blends	WOOL	Steam iron inside out or use an ironing cloth.
Cotton Blends	COTTON	Check label and follow manufacturer's instructions. Use setting for the fiber requiring the lowest setting.
Corduroy	COTTON	Steam iron inside out or use ironing cloth and brush to raise the pile.
Cotton	COTTON	Dry iron while still damp or use steam.
Linen	LINEN	Iron inside out or use an ironing cloth to prevent shine marks, especially with dark colors. Dry iron while still damp or use steam.
Denim	LINEN	Use steam.

Steam as desired

Dry ironing at any setting

# USER MAINTENANCE INSTRUCTIONS

This appliance requires little maintenance and contains no user serviceable parts. Do not try to fix it yourself. Refer it to a qualified repair technician if servicing is needed.

**CAUTION: Always allow Iron to cool completely before cleaning.**

## CARE AND CLEANING:

1. Turn Steam Dial to "OFF".
2. Turn Temperature Dial to "MIN".
3. Unplug Iron from electrical outlet.
4. With Soleplate facing away from you, lift Water Fill Port Cover and carefully turn Iron upside down over a sink. Let remaining water empty out. Shake Iron gently to remove all water from Reservoir. Close Water Fill Port Cover.

**CAUTION: Water in Reservoir may still be hot. Avoid contact with skin.**

5. Wipe the Soleplate with a damp, soft cloth after each use.

**CAUTION: Never use scouring pads, abrasives or chemical cleaners or solvents to clean your coated Soleplate or exterior of the Iron, as these will scratch and/or damage the surface.**

6. Set Iron on its Heel Rest and allow any remaining moisture to evaporate.
7. Wrap cord around the heel rest. Store the Iron on the Heel Rest, not on the Soleplate. If the Iron is stored soleplate down, even the smallest amount of moisture will cause corrosion and staining of the Soleplate.

# USER MAINTENANCE INSTRUCTIONS

(Cont.)

**WARNING: TO PREVENT THE RISK OF BURNS, use caution when cleaning soleplate holes. Burns can occur from touching hot metal parts, hot water, or steam.**

## CLEANING SOLEPLATE HOLES

1. Be sure Iron is unplugged, Steam Dial is "OFF", and Temperature Dial is set to "MIN".
2. Lift Water Fill Port Cover and fill Reservoir (see "Steam Ironing").
3. Plug Iron into electrical outlet.
4. Turn Temperature Dial to "LINEN".
5. As soon as Red Indicator Light turns off, unplug Iron and hold over a sink.
6. With Soleplate facing away from you, turn Steam Dial to steam-cleaning position. See Figure 1. The Iron will force steam out of the holes and clean the holes of calcium and other mineral deposits.
7. Set the Steam Dial back to "OFF" position.
8. Repeat steps 1-7 until no steam comes out of the soleplate holes.

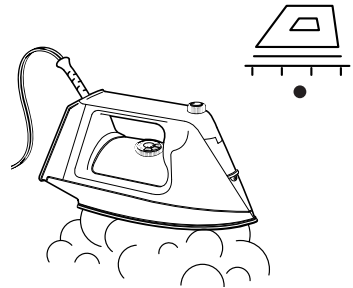

**Figure 1**

# USER MAINTENANCE INSTRUCTIONS

(Cont.)

## CLEANING SOLEPLATE SURFACE

**CAUTION: Unplug the Iron from the electrical outlet before cleaning the exterior of the Iron and storing. Never immerse an appliance in water or other liquid.**

To protect the soleplate from scratching, avoid ironing over snaps, zippers, metal buttons, etc. Also, do not place the iron on metal or rough surfaces. Slight scratches in non-stick soleplates do not affect performance of the iron.

If starch or other residues cling to the soleplate, use a commercial type hot iron cleaner (found in local grocery or discount or hardware stores) according to products directions.

The Iron should be fully cooled before Soleplate cleaning begins. Make sure the Iron is unplugged before cleaning. Empty the Water Tank of any remaining water. Apply a small amount of mild cleaner to a damp cloth. Gently rub Soleplate, then wipe with a moist cloth. **NEVER USE** scouring pads or abrasives cleaners on the Soleplate, as this may scratch the surface. Wipe all other surfaces with a slightly damp cloth. Never allow water or any other liquid to get into the unit, except when filling the Water Tank. **NEVER** put any chemical cleaning agents or solvents in the Water Tank.

**BEFORE USING AGAIN**, preheat and move Iron over an old cloth several times to remove any residue from the Soleplate.

## STORAGE

Unplug appliance and empty any water left in water tank. Allow unit to cool. **STORE IN UPRIGHT POSITION ON HEEL REST.** Never store Iron lying on the Soleplate. Never store it while it is hot or still plugged in. Never wrap cord tightly around the appliance. Do not put any stress on the cord where it enters the unit, as it could cause the cord to fray and break.

## LIMITED ONE-YEAR WARRANTY

**Warranty Coverage:** This product is warranted to be free from defects in materials or workmanship for a period of one (1) year from the original purchase date. This product warranty is extended only to the original consumer purchaser of the product and is not transferable. For a period of one (1) year from the date of original purchase of the product, our Repair Center will, at its option, either (1) repair the product or (2) replace the product with a reconditioned comparable model. These remedies are the purchaser's exclusive remedies under this warranty.

**Warranty Service:** To obtain warranty service, you must call our warranty service number at 1-800-233-9054 for return instructions on how to deliver the product, in either the original packaging or packaging affording an equal degree of protection to the Repair Center specified below. You must enclose a copy of your sales receipt or other proof of purchase to demonstrate eligibility for warranty coverage.

**To return the appliance, ship to:**

ATTN: Repair Center  
708 South Missouri Street  
Macon, MO 63552 USA

**To contact us, please write to, call, or email:**

Consumer Relations Department  
PO Box 7366  
Columbia MO 65205-7366 USA  
1-800-233-9054  
E-mail:  
consumer\_relations@toastmaster.com

**What Is Not Covered:** This warranty does not cover damage resulting from misuse, accident, commercial use, improper service or any other damage caused by anything other than defects in material or workmanship during ordinary consumer use. This warranty is invalid if the serial number has been altered or removed from the product. This warranty is valid only in the United States and Canada.

**LIMITATION ON DAMAGES:** THERE SHALL BE NO LIABILITY FOR ANY INCIDENTAL OR CONSEQUENTIAL DAMAGES FOR BREACH OF ANY EXPRESS OR IMPLIED WARRANTY OR CONDITION ON THIS PRODUCT.

**DURATION OF IMPLIED WARRANTIES:** EXCEPT TO THE EXTENT PROHIBITED BY APPLICABLE LAW, ALL IMPLIED WARRANTIES AND CONDITIONS, INCLUDING, WITHOUT LIMITATION, IMPLIED WARRANTIES AND CONDITIONS OF MERCHANTABILITY AND FITNESS FOR A PARTICULAR PURPOSE OR USE ON THIS PRODUCT ARE LIMITED IN DURATION TO THE DURATION OF THIS WARRANTY.

Some jurisdictions do not allow the exclusion or limitation of incidental or consequential damages, or allow limitations on how long an implied warranty lasts, so the above limitations or exclusions may not apply to you. This warranty gives you specific legal rights and you may have other rights under the laws of your jurisdiction.

For more information on our products, visit our website: [www.maxim-toastmaster.com](http://www.maxim-toastmaster.com).