

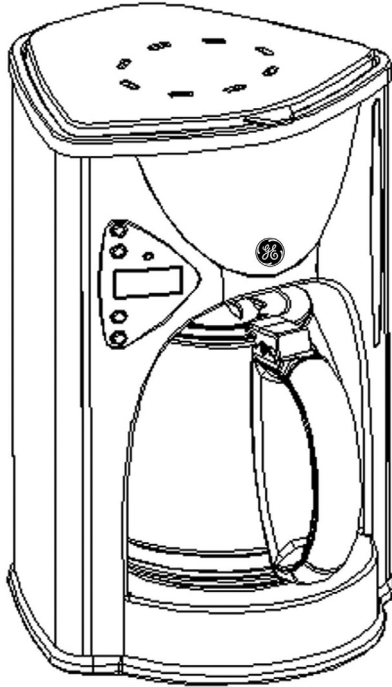

# COFFEE MAKER



## Item Stock Number

*169058, 169101 (US), 169086, 169102 (Canada)*

*UPC: 681131690584, 681131691017 (US),  
681131690867, 681131691024 (Canada)*

**For Customer Assistance, call Customer Service at  
1-877-207-0923 (US) or 1-877-556-0973 (Canada)**

# IMPORTANT SAFEGUARDS

When using electrical appliances, basic safety precautions should always be followed, including the following:

- **READ ALL INSTRUCTIONS .**
- Do not touch hot surfaces. Use handles or knobs.
- To protect against electric shock, do not place cord, plugs, or appliance in water or other liquid.
- Close supervision is necessary when any appliance is used by or near children.
- Unplug from outlet when not in use and before cleaning. Allow to cool before putting on or taking off parts, and before cleaning the appliance.
- Do not operate any appliance with a damaged cord or plug or after the appliance malfunctions, or has been damaged in any manner. Call our toll-free customer service number for information on examination, repair or adjustment.
- Do not use outdoors.
- Do not let cord hang over edge of table or counter, or touch hot surfaces.
- Do not place on or near a hot gas or electric burner, or in a heated oven or in a heated oven.
- Do not use appliance for other than intended use.
- The container is designed for use with this appliance. It must never be used on a range top.
- Do not use a cracked container or a container having a loose or weakened handle.
- Do not clean container with cleansers, steel wool pads, or other abrasive material.
- Do not set a hot container on a hot or cold surface.
- Never leave the empty carafe on the keeping warm plate. Otherwise the carafe is liable to crack.
- To reduce risk of scalding, do not open lid when coffee is brewing.

# SAVE THESE INSTRUCTIONS!

## Consumer Safety Information

*This unit is for household use only.*

### Polarized Plug

This appliance has a polarized plug, (one blade is wider than the other). As a safety feature to reduce the risk of electrical shock, this plug is intended to fit in a polarized outlet only one way. If the plug does not fit fully in the outlet, reverse the plug. If it still does not fit, contact a qualified electrician. Do not attempt to defeat this safety feature.

**CAUTION:** A short power supply cord is provided to reduce the risk of personal injury resulting from becoming entangled in or tripping over a longer cord. Extension cords are available from local hardware stores and may be used if care is exercised in their use. If an extension cord is required, special care and caution is necessary. Also the cord must be: (1) marked with an electrical rating of 125V, and at least 15A., 1500W., and (2) the cord must be arranged so that it will not drape over the countertop or tabletop where it can be pulled on by children or tripped over accidentally.

### Electrical Power

If electric circuit is overloaded with other appliances, your appliance may not operate properly. It should be operated on a separate electric circuit from other appliance.

**CAUTION:** UNPLUG APPLIANCE FROM ELECTRICAL OUTLET WHEN ASSEMBLING, REMOVING PARTS OR CLEANING. NEVER PLACE THIS APPLIANCE OR CORD IN WATER OR OTHER LIQUIDS.

# PARTS AND FEATURES

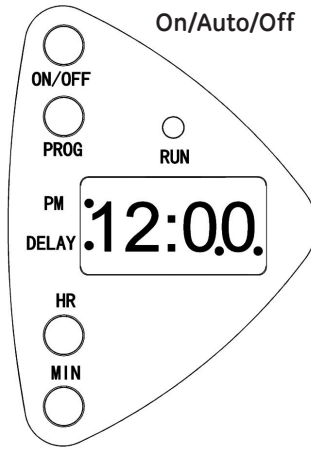
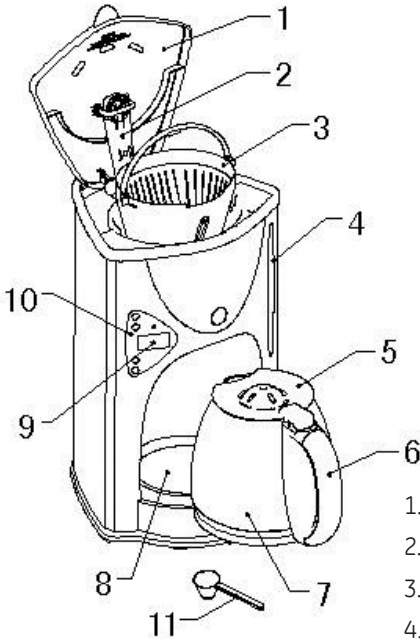

- |                      |                     |
|----------------------|---------------------|
| 1. Water tank cover  | 7. Glass carafe     |
| 2. Hot water sprayer | 8. Heating plate    |
| 3. Filter Basket     | 9. Clock            |
| 4. Water level gauge | 10. Control Panel   |
| 5. Carafe lid        | 11. Measuring spoon |
| 6. Carafe handle     |                     |

# FEATURES

- Removable filter basket
- Non-stick heating plate to keep your coffee hot after brewing
- Pause-N-Pour feature
- Brew capacity 12 cups
- LED illuminate blue light when power on
- Programmable control feature:  
Clock and Timer  
Two-Hour Auto Shut Off  
Delay Brew Function

# COFFEE MAKER MODEL

Model No.	Rated voltage	Rated power	Capacity	Dimensions	Weight
169058, 101, 086, 102	120V	900W	1.8L	240 x 230 x 367mm 9.45" x 9.05" x 14.45"	2071g 4.5 lbs.

# OPERATING INSTRUCTIONS

Before first use, it is recommended that you fill to the maximum level mark with fresh water, boil and empty the coffee maker at least 2 times to clear coffee maker of any tiny particles. Do not drink the water.

## Ground Coffee Usage Instructions;

To Brew	Coffee
12 cups	9 Tbsp.
10 cups	7 Tbsp.
8 cups	6 Tbsp.
6 cups	4 Tbsp.
4 cups	2 Tbsp.

## To Set the Clock

1. Plug the power cord into a standard electrical outlet. "12:00" will blink on LED display.
2. Press the hold the "HR" or "MIN" buttons until you reach the current time. If the time of holding the "HR" or "MIN" button exceeds 2 seconds, it will activate a rapid time advance of hours or minutes.

## To Set the Timer

1. After setting the clock, press "PROG" button and at the same time press the "HR" or "MIN" buttons to set the required delay brew time.
2. To activate the brewing timer, press the "ON/AUTO/OFF" button twice. The "DELAY" indicator will illuminate.
3. At the present time, the "RUN" indicator will illuminate blue and the coffee maker will begin brewing coffee automatically.
4. To deactivate the brewing timer, press the "ON/AUTO/OFF" button once again.

**Note:** To check the programmed time, press the "PROG" button. The display will show the delay brew time you have set.

# PROPER FILTER BASKET RE-INSTALLATION INSTRUCTIONS



- Water will overflow if filter basket is not locked firmly and properly.
- Basket should not move when engaged properly.
- Use a #4 cone paper filter after filter basket has been re-installed.

1

With coffee lid open, locate slot on both sides of the opened coffee maker.

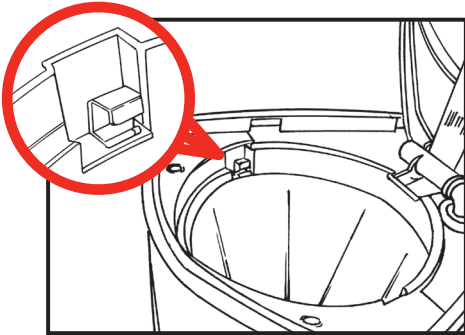

2

Locate tabs on filter basket and lower basket into coffee maker with the handle upright.

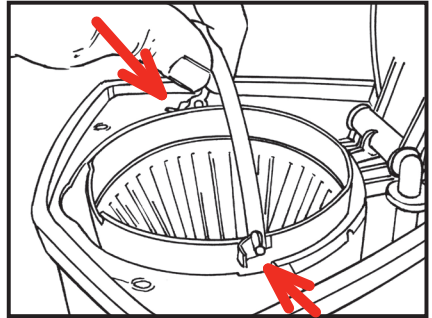

3

Firmly press the filter basket into coffee maker while holding handle upright.

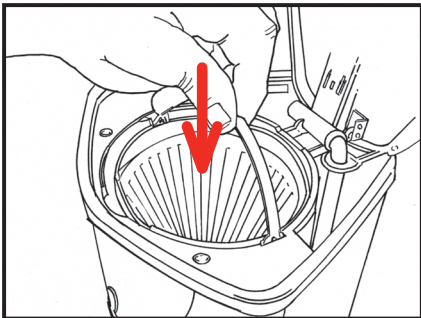

4

Lower basket handle down so that tabs lock under slots. You may now install the paper filter.

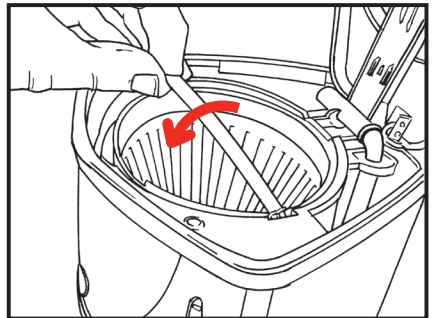

# OPERATING INSTRUCTIONS

## To Brew Coffee:

1. Ensure that the filter basket is properly seated; place one #4 cone paper filter into the filter basket.
2. Add desired amount of coffee according to the coffee measurement chart found above. Shake lightly to level coffee.
3. Open the water tank cover and fill the water tank with the correct amount of water for the desired number of cups of coffee as indicated on the water gauge.
4. Close the water tank cover and place the carafe on the warming plate.
5. For immediate brewing, plug the power cord into a standard 120 volt AC electrical outlet and press the "ON/AUTO/OFF" button once; the "RUN" indicator will illuminate blue. For the Delay Brew time, see the "To Set The Timer" section.

**Note:** After a loss of electrical power, if the appliance is plugged in again within 10 seconds, it will resume to the original state.

6. When coffee stops dripping, the brewing cycle is complete. Carefully remove the filter basket and discard the used ground coffee and paper filter. Rinse the filter basket and replace.

**Note:** The amount of brewed coffee will be less than the amount of water poured into the product as the ground coffee absorbs some water during brewing.

7. To keep the coffee warm, return the carafe to the warming plate after pouring coffee.
8. Press the "ON/AUTO/OFF" button twice to turn off the product; the "RUN" indicator will shut off. Unplug the power cord from the electrical outlet when the product is not in use or the carafe is empty.

## Pause n Serve

This feature allows you to pour a cup of coffee before the entire brew cycle has completed. By removing the Carafe, the flow of coffee from the bottom of the filter basket will stop.

**Caution:** Return carafe to warming plate within 20 seconds. Hot water continues to flow into the filter basket when this feature is used. Overflowing coffee and hot water are a burn hazard.

## Automatic Shutoff

The Automatic Shutoff feature shuts off the warming plate 2 hours after brew cycle begins. Always turn coffee maker off and unplug when finished.

# CLEANING

**Caution :** Be sure to unplug this appliance before cleaning. To protect against electrical shock, do not immerse cord, plug or unit in water or other liquids. After each use, always make sure plug is first removed from wall outlet.

1. Clean carafe and carafe lid after each use in hot, soapy water.
2. Wipe the product's exterior surface with a soft, damp cloth to remove stains.
3. Use a damp cloth to gently wipe the warming plate. Never use abrasive cleaner to clean it.

## **Cleaning Mineral Deposits**

To keep your coffee maker operating efficiently, you should clean away the mineral deposits left by the water regularly according to the water quality in your area and the frequency using the appliance, the detail is as follows: fill the carafe with one part of white vinegar and three parts of cold water, pour the water and vinegar mixture into the tank, do not place into coffee ground, brewing the water-vinegar solution per "operating instructions", repeat it until no yellow liquid comes out if necessary, then pour out the mixture, brewing with tap water until no vinegar odor is left.



# CUSTOMER ASSISTANCE

If you have a claim under this warranty, please call our Customer Assistance Number. For faster service, please have the model number and product name ready for the operator to assist you. This number can be found on the bottom of your appliance and on the front page of this manual.

**Model Number:** \_\_\_\_\_ **Product Name:** \_\_\_\_\_

Customer Assistance Number 1.877.207.0923 (US) or 1.877.556.0973 (Canada)

Keep these numbers for future reference!

For more information, please visit us at [www.gehousewares.com](http://www.gehousewares.com)

## TWO-YEAR LIMITED WARRANTY

### What does your warranty cover?

- Any defect in material or workmanship.

### For how long after the original purchase?

- Two years.

### What will we do?

- Provide you with a new one.
- For those items still under warranty but no longer available, WAL-MART reserves the right to replace with a similar GE branded product of equal or greater value.

### How do you make a warranty claim?

- Save your receipt.
- Properly pack your unit. We recommend using the original carton and packing materials.
- Return the product to your nearest WAL-MART store or call Customer Assistance at 1-877-207-0923 (U.S.) or 1-877-556-0973 (Canada).

### What does your warranty not cover?

- Parts subject to wear, including, without limitation, glass parts, glass containers, cutter/strainer, blades, seals, gaskets, clutches, motor brushes, and/or agitators, etc.
- Commercial use or any other use not found in printed directions.
- Damage from misuse, abuse, or neglect, including failure to clean product regularly in accordance with manufacturer's instructions.

### How does state law relate to this warranty?

- This warranty gives you specific legal rights, and you may also have other rights which vary from state to state or province to province.
- This warranty is in lieu of any other warranty or condition, whether express or implied, written or oral, including, without limitation, any statutory warranty or condition of merchantability or fitness for a particular purpose.
- WAL-MART, GE and the product manufacturer expressly disclaim all responsibility for special, incidental and consequential damages or losses caused by use of this appliance. Any liability is expressly limited to an amount equal to the purchase price paid whether a claim, however instituted, is based on contract, indemnity, warranty, tort (including negligence), strict liability, or otherwise. Some states or provinces do not allow this exclusion or limitation of incidental or consequential losses so the foregoing disclaimer may not apply to you.

### What if you encounter a problem with this product while using it outside the country of purchase?

- The warranty is valid only in the country of purchase and you follow the warranty claim procedure as noted.



is a trademark of General Electric Company and is used under the license by Wal-Mart Stores Inc., Bentonville, AR 72716

### Marketed in Canada by:

Wal-Mart Canada Corp.

1940 Argentia Road, Mississauga, Ontario L5N1P9