



WELLS MANUFACTURING COMPANY
2 ERIK CIRCLE, P. O. Box 280
Verdi, NV 89439
telephone: 775-689-5700
fax: 888-492-2783
www.wellsbloomfield.com

224



Model HC-2256

**OPERATION
MANUAL**
for
**BUILT-IN
CERAMIC
HOTPLATES**
**Models:
HC-1006
HC-1256
HC-2256**

**Includes
INSTALLATION
USE & CARE**

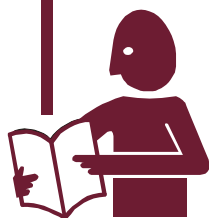

IMPORTANT: DO NOT DISCARD THIS MANUAL

This manual is considered to be part of the appliance and is to be given to the OWNER or MANAGER of the restaurant, or to the person responsible for TRAINING OPERATORS of this appliance. Additional manuals are available from your WELLS DEALER.

THIS MANUAL MUST BE READ AND UNDERSTOOD BY ALL PERSONS USING OR INSTALLING THIS APPLIANCE. Contact your WELLS DEALER if you have any questions concerning installation, operation or maintenance of this equipment.

LIMITED WARRANTY STATEMENT

Unless otherwise specified, all commercial cooking equipment manufactured by WELLS MFG. CO. is warranted against defects in materials and workmanship for a period of one year from the date of original installation or 18 months from the date of shipment from our factory, whichever comes first, and is for the benefit of the original purchaser only.

THIS WARRANTY IS THE COMPLETE AND ONLY WARRANTY, EXPRESSED OR IMPLIED IN LAW OR IN FACT, INCLUDING BUT NOT LIMITED TO, WARRANTIES OF MERCHANTABILITY OR FITNESS FOR ANY PARTICULAR PURPOSE, AND/OR FOR DIRECT, INDIRECT OR CONSEQUENTIAL DAMAGES IN CONNECTION WITH WELLS MFG. CO. PRODUCTS. This warranty is void if it is determined that, upon inspection by an authorized service agency, the equipment has been modified, misused, misapplied, improperly installed, or damaged in transit or by fire, flood or act of God. It also does not apply if the serial nameplate has been removed, or if service is performed by unauthorized personnel. The prices charged by Wells Mfg. Co.

for its products are based upon the limitations in this warranty. Seller's obligation under this warranty is limited to the repair of defects without charge by a Wells Mfg. Co. factory authorized service agency or one of its sub-service agencies. This service will be provided on customer's premises for non-portable models. Portable models (a device with a cord and plug) must be taken or shipped to the closest authorized service agency, transportation charges prepaid, for service. In addition to restrictions contained in this warranty, specific limitations are shown in the Service Policy and Procedure Guide. Wells Mfg. Co. authorized service agencies are located in principal cities. This warranty is valid in the United States and Canada and void elsewhere. Please consult your classified telephone directory, your foodservice equipment dealer or write:

Factory Service Department, Wells Manufacturing Company,
P.O. Box 280, Verdi, Nevada 89439,
phone (775) 689-5700 or (888) 492-2782,
for information and other details concerning warranty.

SERVICE POLICY AND PROCEDURE GUIDE ADDITIONAL WARRANTY EXCLUSIONS

1. Resetting of safety thermostats, circuit breakers, over load protectors, and/or fuse replacements are **not** covered by this warranty unless warranted conditions are the cause.
2. All problems due to operation at **voltages or phase other than specified on equipment nameplates** are **not** covered by this warranty. Conversion to correct voltage and/or phase must be the customer's responsibility.
3. All problems due to **electrical connections not made in accordance with electrical code requirements and wiring diagrams** supplied with the equipment are **not** covered by this warranty.
4. Replacement of items **subject to normal wear**, to include such items as knobs, light bulbs; and, normal maintenance functions including adjustments of thermostats, adjustment of micro switches and replacement of fuses and indicating lights are **not** covered by warranty.
5. Damage to electrical cords and/or plug due to exposure to excessive heat are **not** covered by this warranty.
6. Full use, care, and maintenance instructions supplied with each machine. Noted maintenance and preventative maintenance items, such as servicing and cleaning schedules, are customer responsibility. Those miscellaneous adjustments noted are customer responsibility. Proper attention to preventative maintenance and scheduled maintenance procedures will prolong the life of the appliance.
7. Travel mileage is limited to **sixty (60) miles** from an Authorized Service Agency or one of its sub-service agencies.
8. All labor shall be performed during regular working hours. Overtime premium will be charged to the buyer.
9. All genuine Wells replacement parts are warranted for ninety (90) days from date of purchase on non-warranty equipment. This parts warranty is limited only to replacement of the defective part(s). **Any use of non-genuine Wells parts completely voids any warranty.**
10. Installation, labor, and job check-outs are **not** considered warranty and are thus **not** covered by this warranty.
11. Charges incurred by delays, waiting time or operating restrictions that hinder the service technician's ability to perform service are **not** covered by warranty. This includes institutional and correctional facilities.

SHIPPING DAMAGE CLAIM PROCEDURE

NOTE: For your protection, please note that equipment in this shipment was carefully inspected and packaged by skilled personnel before leaving the factory.

Upon acceptance of this shipment, the transportation company assumes full responsibility for its safe delivery.

IF SHIPMENT ARRIVES DAMAGED:

1. **VISIBLE LOSS OR DAMAGE:** Be certain that any visible loss or damage is noted on the freight bill or express receipt, and that the note of loss or damage is signed by the delivery person.
2. **FILE CLAIM FOR DAMAGE IMMEDIATELY:** Regardless of the extent of the damage.

3. **CONCEALED LOSS OR DAMAGE:** if damage is unnoticed until the merchandise is unpacked, notify the transportation company or carrier immediately, and file "CONCEALED DAMAGE" claim with them. This should be done within fifteen (15) days from the date the delivery was made to you. Be sure to retain the container for inspection.

Wells Manufacturing cannot assume liability for damage or loss incurred in transit. We will, however, at your request, supply you with the necessary documents to support your claim.

TABLE OF CONTENTS

WARRANTY	xi
SPECIFICATIONS	1
FEATURES & OPERATING CONTROLS	2
PRECAUTIONS & GENERAL INFORMATION	3
INSTALLATION	4
OPERATION	5
CLEANING INSTRUCTIONS	6
SPECIAL CARE INSTRUCTIONS	7
TROUBLESHOOTING	8
PARTS & SERVICE	9
CUSTOMER SERVICE DATA	9

INTRODUCTION

Thank You for purchasing this Wells Manufacturing Co. appliance.

Proper installation, professional operation and consistent maintenance of this equipment will ensure that it gives you the very best performance and a long, economical service life.

This manual contains the information needed to properly install this equipment, and to use and care for the equipment in a manner which will ensure its optimum performance.

SPECIFICATIONS

MODEL	ELEMENT	VOLTS	AMPS	kW	FIELD WIRING	
HC-1006	Single 7"	120 V 1 \emptyset	11.7 A	1.4 kW	14 ga. 75°C	
HC-1256	Single 9"	208 V 1 \emptyset	9.0 A	1.9 kW	10 ga. 75°C	
		240 V 1 \emptyset	10.4 A	2.5 kW	10 ga. 75°C	
HC-2256	Dual 9"	208 V 1 \emptyset	18.1 A	3.8 kW	10 ga. 75°C	3 \emptyset versions available Refer to Installation Guide for details
		240 V 1 \emptyset	20.8 A	5.0 kW	10 ga. 75°C	

NOTE: See installation guide for cutout dimensions

SPECIFICATIONS — ☞ EXPORT MODELS

MODEL	ELEMENT	VOLTS	AMPS	kW	FIELD WIRING
HC-1256EU	Single 9"	220-240V 1 \emptyset	10.4 A	2.5 kW	1.5 mm ²
HC-2256EU	Dual 9"	220-240V 1 \emptyset	20.8 A	5.0 kW	2.5 mm ²

Refer to the Export Manual for this equipment (p/n 301399) for specific ☞ information.

FEATURES & OPERATING CONTROLS

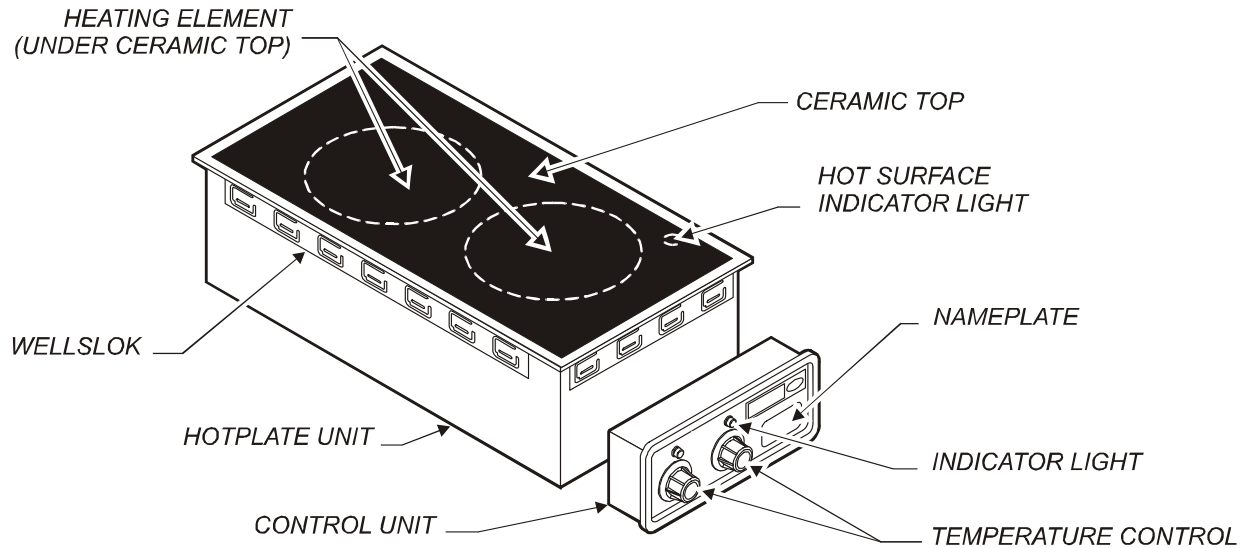

Fig. 1 Built-In Ceramic Hotplate - Features & Operating Controls

HOTPLATE UNIT

Ceramic Top	Provides smooth, low maintenance heating surface
Heating Element	Provides heat for food preparation Note: elements located under ceramic top
Hot Surface Indicator Light	Glows whenever ceramic top is above 150°F (66°C)
Wellsloks	Unique turn-out tabs which help secure the hotplate to the counter

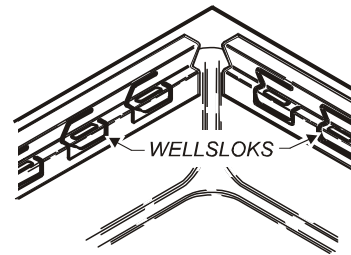

Fig. 2 Wellsloks

CONTROL UNIT

Temperature Controls	Infinite switches to control temperature of heating elements
Power Indicator Light	Glows any time temperature control is on
Name Plate	Lists manufacturer, model number and serial number Also lists voltage and wattage rating

PRECAUTIONS AND GENERAL INFORMATION

This appliance is intended for use in commercial establishments only.

This appliance is intended to prepare food for human consumption. No other use is recommended or authorized by the manufacturer or its agents.

Operators of this appliance must be familiar with the appliance use, limitations and associated restrictions. Operating instructions must be read and understood by all persons using or installing this appliance.

Cleanliness of this appliance is essential to good sanitation. Read and follow all included cleaning instructions and schedules to ensure the safety of the food product.

Disconnect the hotplate from electrical power before performing any maintenance or servicing.

DO NOT splash or pour water over, onto or into controls or wiring.

Hotplate must be installed by a licensed electrician with full knowledge of all applicable electrical codes.

The technical content of this manual, including any wiring diagrams, schematics, parts breakdown illustrations and/or adjustment procedures, is intended for use by qualified technical personnel.

Any procedure which requires the use of tools must be performed by a qualified technician.

This manual is considered to be a permanent part of the appliance. This manual and all supplied instructions, diagrams, schematics, parts breakdown illustrations, notices and labels must remain with the appliance if it is sold or moved to another location.

This appliance is made in the USA. Unless otherwise noted, this appliance has American sizes on all hardware.



WARNING: ELECTRIC SHOCK HAZARD

All servicing requiring access to non-insulated electrical components must be performed by a factory authorized technician. DO NOT open any access panel which requires the use of tools. Failure to follow this warning can result in severe electrical shock.



CAUTION: RISK OF DAMAGE

DO NOT connect and/or energize this appliance until all installation instructions are read and followed. Damage to the appliance will result if these instructions are not followed.

AGENCY APPROVAL INFORMATION

This appliance is  and  listed under file E6070

This appliance conforms to NSF Standard 4 for sanitation only if installed in accordance with the supplied *Installation Instructions*.

Export (only) versions of this appliance meet  requirements.



E6070



E6070



STD 4



EXPORT MODELS
ONLY

INSTALLATION

NOTE: DO NOT discard the carton or other packing materials until you have inspected the appliance for hidden damage and tested it for proper operation. Refer to *SHIPPING DAMAGE CLAIM PROCEDURE* on the inside front cover of this manual.

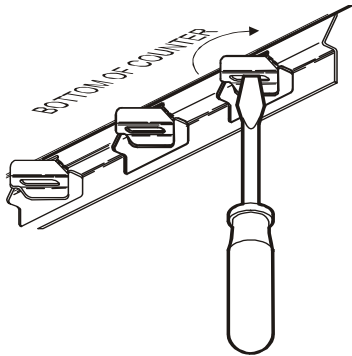

Fig. 3 Set the Wellsloks

IMPORTANT:

Water damage caused by failure to seat Wellsloks or failure to install gasket or to seal flange to counter is NOT covered by warranty

IMPORTANT:

Contact a licensed electrician to install and connect electrical power to the hotplate.

IMPORTANT:

Damage due to being connected to the wrong voltage or phase is NOT covered by warranty.

UNPACKING & INSPECTION

Carefully remove the hotplate from the carton. Remove all protective plastic film, packing materials and accessories from the hotplate before connecting the hotplate into electrical power or otherwise performing any installation procedure.

Carefully read all instructions in this manual and the *Installation Instruction Sheet* packed with the hotplate before starting any installation.

Read and understand all labels and diagrams attached to the hotplate.

Carefully account for all components and accessories before discarding packing materials. Store all accessories in a convenient place for later use.

PREPARATION

Carefully read the *Installation Instruction Sheet* packed with the hotplate for cutout dimensions and restrictions.

For wood and non combustible (i.e. metal) installation, do not install closer than 1 inch to back and side walls, 3-5/8" between unit

Supplied gasket must be installed under the mounting flange, and the Wellsloks turned out to seal the hotplate and control unit to the counter.

Apply a thin bead of food-grade silicone sealant where the flange meets the counter.

ELECTRICAL

Hotplate must be installed by a licensed electrician in accordance with all applicable codes and ordinances.

Refer to the nameplate. Verify the electrical service power. Voltage and phase must match the nameplate specifications. Connecting the hotplate to the wrong voltage can severely damage the equipment or cause noticeably decreased performance.

For supply connections, use 14 ga. (HC-1006) or 10 ga. (HC-1256 and HC-2256) copper wires suitable for at least 75°C.

The ground lug of the hotplate and control unit must be connected to a suitable building ground.

GENERAL OPERATIONAL NOTES

Carefully read the description of the hotplate operation on the specification sheet.

DO NOT attempt to perform any maintenance or service unless the hotplate is disconnected from electrical power.

DO disconnect the hotplate from electrical power or turn the circuit breaker off before cleaning or servicing.

DO NOT use steel wool or abrasive cleansers to clean the ceramic top.

DO use the supplied scraper to remove burned-on food product.

OPERATION

Each heating element is controlled by an infinite switch temperature control:

- OFF removes power from the element
- LOW thru 8 are temperature settings
- Higher numbers indicate higher temperatures
- There is a continuous range of settings between LOW and HI
- HI is a continuous ON setting

The power indicator light will glow any time the temperature control is on.

The *hot surface indicator* light will glow any time the ceramic surface is approximately 150°F (65°C) or higher.

Cooking Recommendations:

Save energy by turning the temperature control off any time the hotplate is not in use. The heating elements will provide full heat within 30 seconds, making it unnecessary to leave the unit on during intermittent use.

Each heating section can hold up to a 16 quart pot or pan. For efficient heating of food product, pots and pans should be no more than 10” in diameter. Maximize the efficiency of the ceramic top by using flat-bottom pots and pans.

Preserve the luster of the ceramic cook surface by wiping up spills promptly and by cleaning frequently. Allow the hotplate to cool completely before cleaning. Use only cook-top cleaning crème on glass-ceramic cooking surfaces.

Stir thick liquids frequently to maintain a consistent temperature.



**CAUTION:
HOT SURFACE**

Exposed surfaces can be hot to the touch and may cause burns.



**CAUTION:
HOT SURFACE**

Ceramic cooking surfaces are hot anytime the HOT SURFACE indicator light is lit. DO NOT touch the cooking surface if the HOT SURFACE light is lit.

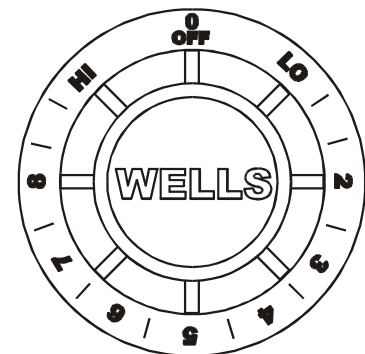

Fig. 4 Temperature Control

IMPORTANT:

The dial markings are an INDICATION of temperature only. The temperature of the food product depends on many factors, including the size, shape and material of the food container, and the quantity and consistency of the food product.

CLEANING INSTRUCTIONS



CAUTION:
ELECTRIC SHOCK
HAZARD

Disconnect hotplate from electric power before cleaning.



CAUTION:
BURN HAZARD

Allow hotplate to cool completely before cleaning.



CAUTION:
ELECTRIC SHOCK
HAZARD

Do not submerge hotplate in water.

IMPORTANT:

DO NOT spill or pour water into controls, control panel or wiring.

DO NOT pour water over hotplate ceramic surface. Damage to internal components will occur. Damage to internal components from water damage is NOT covered by warranty.

DO NOT use steel wool, metal implements other than the provided scraper, or metal scouring pads to clean ceramic heating surface.

PREPARATION

Disconnect hotplate from electrical power before cleaning. Allow hotplate to cool completely before cleaning.

FREQUENCY

Daily

TOOLS

Cleaning Creme
Razor Scraper
Clean Cloth or Sponge
Mild Detergent or Cleaner Formulated for Stainless Steel
Warm Water

CLEANING

Disconnect hotplate from electrical power before cleaning.

Allow the hotplate to cool until the HOT SURFACE indicator light goes off before cleaning.

Clean food particles from the ceramic cooking surface with a razor scraper. Hold the edge of blade flat against the surface and at a 15° angle to avoid scratching the ceramic. DO NOT use metal implements (other than the razor scraper), steel wool or metal scouring pads to clean the ceramic cooking surface.

Use only cook-top cleaning creme (p/n 501124) on glass-ceramic cooking surfaces. Wipe the ceramic cooking surfaces with cleaning creme and a clean cloth. The cleaning creme leaves a protective coating.

Wipe the outer portions of the hotplate control unit with a clean soft cloth or sponge dampened with warm water and a mild detergent or cleaner formulated for cleaning stainless steel. DO NOT use steel wool to clean hotplate control unit.

Rinse by wiping hotplate control unit with a clean soft cloth or sponge moistened with clean warm water. Dry by wiping with a clean soft dry cloth.

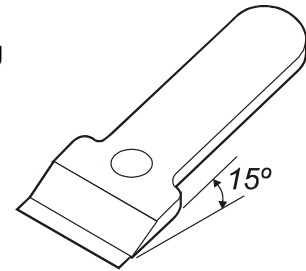

Fig. 5 Razor Scraper

SPECIAL CARE INSTRUCTIONS

DO NOT use the hotplate surface as a cutting board.

DO NOT cook directly on the glass-ceramic surface.

Check glass and ceramic cookware to verify suitability for use on hotplates.

DO NOT drop cookware onto glass-ceramic cook surface. Carefully place heavy pots and skillets on glass-ceramic cook surface to avoid damage.

Avoid sliding cookware across hotplate surface.

Remove stains and metal marks from the glass-ceramic cook surface after use by cleaning with cleaning creme. Allow hotplate surface to cool completely before cleaning

DO NOT leave empty cookware on a hot cooking surface.

Avoid contacting the hot glass-ceramic surface with plastic or aluminum foil, which may melt.



**CAUTION:
BURN HAZARD**

Allow hotplate to cool completely before cleaning.



**CAUTION:
CUT HAZARD**

DO NOT attempt to cook on a broken hotplate surface. Severe injury may result. Contact an Authorized Wells Service Agency immediately for repairs.



**CAUTION:
CUT HAZARD**

DO NOT attempt to repair a broken hotplate surface. The glass-ceramic surface is impossible to repair successfully. A broken ceramic top can cause severe injury. Contact an Authorized Wells Service Agency immediately for repairs.

TROUBLESHOOTING

SYMPTOM	POSSIBLE CAUSE	SUGGESTED REMEDY
Hotplate won't heat	Disconnect turned OFF or circuit breaker tripped	Turn disconnect ON Check / reset circuit breaker
One or more sections won't heat	Temperature control not on	Turn temperature control to desired setting
	Damaged temperature control, element or other internal component	Contact Authorized Wells Service Agency for repairs
Hotplate not hot enough	Temperature control not set	Adjust for desired temperature
	Operating 208/240V unit at 120V	Be sure supply voltage matches nameplate voltage
	Damaged temperature control, element or other internal component	Contact Authorized Wells Service Agency for repairs
Hot surface indicator does not light, or stays on	Damaged temperature control, element or other internal component	Contact Authorized Wells Service Agency for repairs

NOTE: There are no user serviceable components in the hotplate. In all cases of damage or component malfunction, contact your Authorized Wells Service Agency for repairs.

DESCRIPTION	SERVICE PART NO.
SCRAPER, CLEANING	22445
CLEANING CRÈME, CERAMIC HOTPLATE	501124

IMPORTANT: Use only factory authorized service parts and replacement filters.

For factory authorized service, or to order factory authorized replacement parts, contact your Wells authorized service agency, or call:

Wells Manufacturing Co.
2 Erik Circle
P. O. Box 280
Verdi, NV 89439
phone: (775) 689-5700
fax: (888) 492-2783
(Service Parts Dept.)

Service Parts Department can supply you with the name and telephone number of the WELLS AUTHORIZED SERVICE AGENCY nearest you.

CUSTOMER SERVICE DATA

please have this information available if calling for service

RESTAURANT _____ LOCATION _____
INSTALLATION DATE _____ TECHNICIAN _____
SERVICE COMPANY _____
ADDRESS _____ STATE _____ ZIP _____
TELEPHONE NUMBER (____) _____ - _____

EQUIPMENT MODEL NO. _____
EQUIPMENT SERIAL NO. _____
VOLTAGE: (check one) 120 208 240



*Wells Manufacturing proudly supports CFESA
Commercial Food Equipment Service Association*

SERVICE TRAINING - QUALITY SERVICE



CUSTOMER SATISFACTION



WELLS

WELLS MANUFACTURING COMPANY - Division of CARRIER COMMERCIAL REFRIGERATION
2 ERIK CIRCLE, P. O. Box 280
Verdi, NV 89439
telephone: 775-689-5700
fax: 888-492-2783
www.wellsbloomfield.com