

Model No. WEMC0942.1

Serial No. \_\_\_\_\_

Write the serial number in the space above for future reference.

# MAX

by WEIDER™

## MAX PACK

### QUESTIONS?

As a manufacturer, we are committed to providing complete customer satisfaction. If you have questions, or if a part is damaged or missing, PLEASE CONTACT OUR CUSTOMER SERVICE DEPARTMENT DIRECTLY.

CALL TOLL-FREE:

**1-877-992-5999**

Mon.–Fri., 6 a.m.–6 p.m. MST

ON THE WEB:

[www.weiderservice.com](http://www.weiderservice.com)

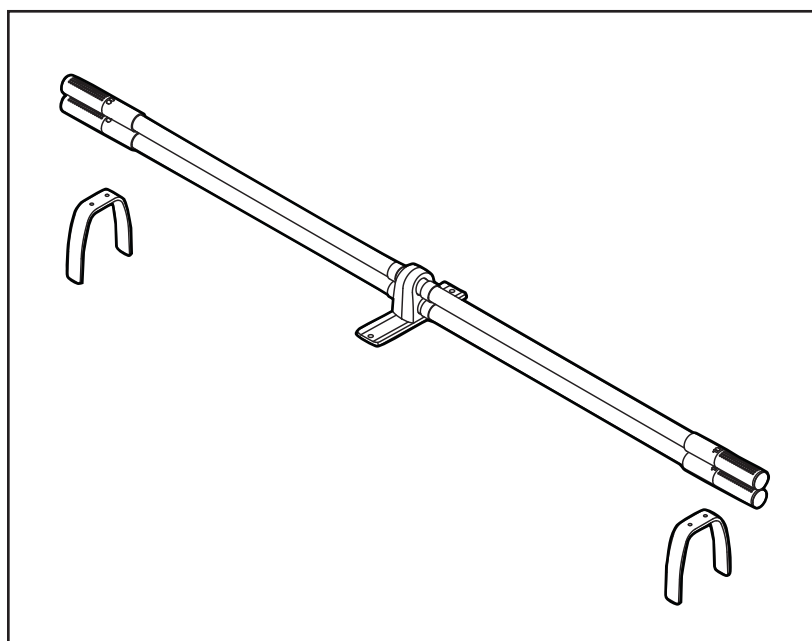

## USER'S MANUAL

### **⚠ CAUTION**

Read all precautions and instructions in this manual before using this equipment. Save this manual for future reference.



Visit our website at

[www.weiderfitness.com](http://www.weiderfitness.com)

new products, prizes,  
fitness tips, and much more!

---

# TABLE OF CONTENTS

IMPORTANT PRECAUTIONS ..... 3  
BEFORE YOU BEGIN ..... 3  
ASSEMBLY ..... 4  
PART LIST/EXPLODED DRAWING ..... 6  
ORDERING REPLACEMENT PARTS ..... Back Cover  
LIMITED WARRANTY ..... Back Cover

---

## IMPORTANT PRECAUTIONS

**⚠ WARNING:** To reduce the risk of serious injury, read the following important precautions before using the resistance system.

1. Read all instructions in this manual and in the literature accompanying the resistance system before using the resistance system. Use the resistance system only as described in the literature.
2. It is the responsibility of the owner to ensure that all users of the resistance system are adequately informed of all precautions.
3. Keep children under 12 and pets away from the resistance system at all times.
4. Keep hands and feet away from moving parts.
5. Use only the resistance included with a MAX PACK. Do not use other types of weight with the resistance system.
6. When adding resistance, both ends of the resistance bars must rest under the two “U”-channels. Add and remove resistance bars from the “U”-channels one resistance bar at a time.
7. Keep clear of the area around the “U”-channels while the resistance system is in use. Do not add or remove resistance bars from the “U”-channels while the end of the long cable is pulled out.
8. Make sure that all parts are properly tightened each time the resistance system is used. Replace any worn parts immediately.
9. If you feel pain or dizziness at any time while exercising, stop immediately and begin cooling down.

**⚠ WARNING:** Before beginning this or any exercise program, consult your physician. This is especially important for persons over the age of 35 or persons with pre-existing health problems. Read all instructions before using. ICON assumes no responsibility for personal injury or property damage sustained by or through the use of this product.

---

## BEFORE YOU BEGIN

Thank you for selecting the MAX by WEIDER™ resistance system MAX PACK accessory. The MAX by WEIDER uses progressive resistance. As the resistance bars begin to bend, the amount of resistance will increase gradually. As the resistance bars bend further, the resistance will increase rapidly. The MAX PACK is designed to increase the amount of resistance available on the MAX by WEIDER resistance system.

**For your benefit, read this manual carefully before using the MAX PACK and the resistance system. If**

you have questions after reading this manual, see the front cover of this manual. To help us assist you, please note the product model number and serial number before calling. The model number is WEMC0942.1. The serial number can be found on the product packaging. Record the serial number on the front cover of this manual.



**To avoid a registration fee for any service needed under warranty, you must register the MAX PACK accessory at [www.weiderservice.com/registration](http://www.weiderservice.com/registration).**

# ASSEMBLY

**Before beginning assembly, carefully read the following information and instructions:**

- Assembly requires two people.
- Tighten all parts as you assemble them, unless instructed to do otherwise.
- Make sure all parts are oriented as shown in the drawings.
- Place all parts in a cleared area and remove the packing materials. Do not dispose of the packing materials until assembly is completed.

**The following tools (not included) are required for assembly:**

- **One standard screwdriver** 
- **One Phillips screwdriver** 
- **One Allen wrench (included with the MAX by WEIDER resistance system)** 

Assembly will be more convenient if you have a socket set, a set of open-end or closed-end wrenches, or a set of ratchet wrenches.

1. **Before beginning assembly, make sure that you have read and understand the information in the box above.**

Attach a Cap (2) to one end of the Resistance Bars (1) with an M4 x 12mm Flat Head Screw (5). **Attach the other Caps in the same manner.**

2. Attach the Cover Plate (3) to the Resistance Bars (1) with two 1/4" x 25mm Flat Head Screws (6). **Make sure the Cover Plate is oriented with the edges up.**

3. Locate the Tray (B) on the resistance system. Remove the two indicated Button Head Screws (C) and the Cover Plate (A) from the Tray. Set the Cover Plate aside. **Note: The resistance bar assembly is shown removed from the resistance system for clarity.**

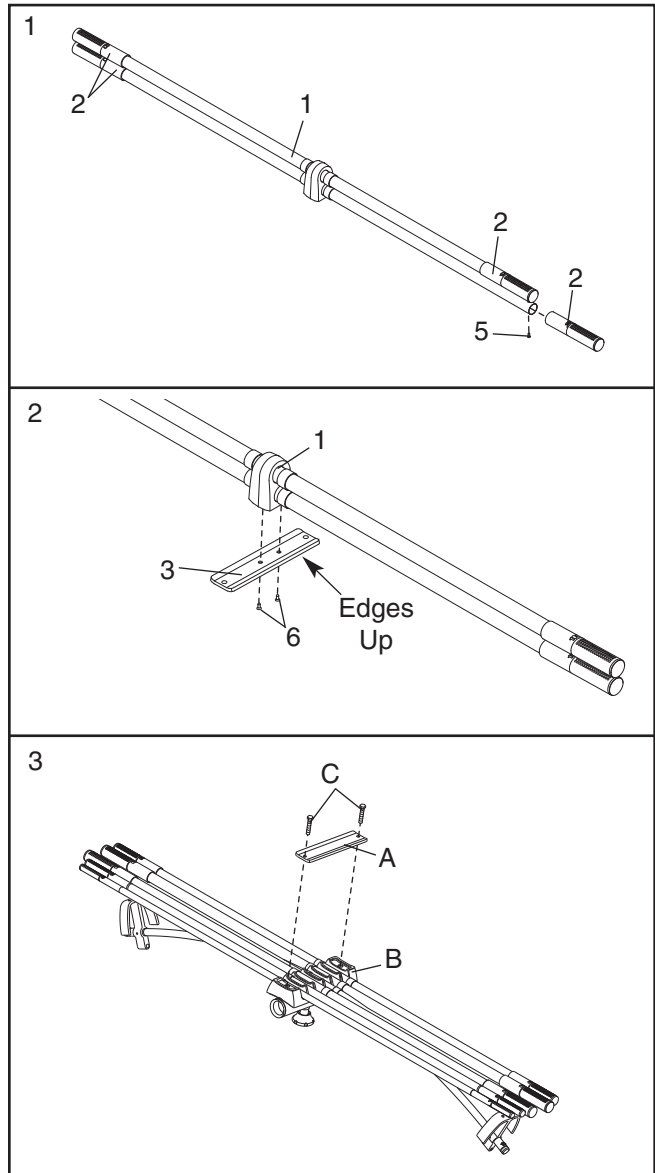

- Attach the Cover Plate (3) to the Tray (B) with the two Button Head Screws (C) that were removed in step 3. **Note: Make sure the decal is over the indicated resistance bars**

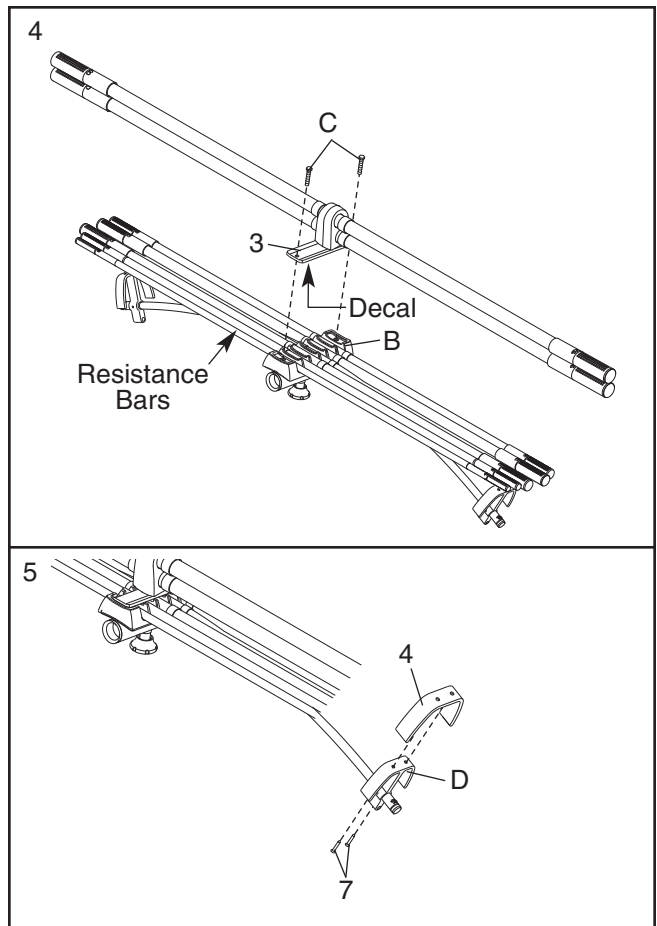

- Attach a “U”-channel Extension (4) to a “U”-channel (D) with two 1/4" x 12mm Flat Head Screws (7).

**Attach the other “U”-channel Extension (4) to the other “U”-channel (D) in the same manner.**

- Make sure that all parts have been properly tightened. To use the MAX PACK to add resistance, refer to ADJUSTING THE RESISTANCE in the resistance system user’s manual.**

# PART LIST/EXPLODED DRAWING—Model No. WEMC0942.1

R1005A

Key No.	Qty.	Description	Key No.	Qty.	Description
1	1	Resistance Bars	5	4	M4 x 12mm Flat Head Screw
2	4	Cap	6	2	1/4" x 25mm Flat Head Screw
3	1	Cover Plate	7	4	1/4" x 12mm Flat Head Screw
4	2	"U"-channel Extension	#	1	User's Manual

Note: "#" indicates a non-illustrated part. Specifications are subject to change without notice.

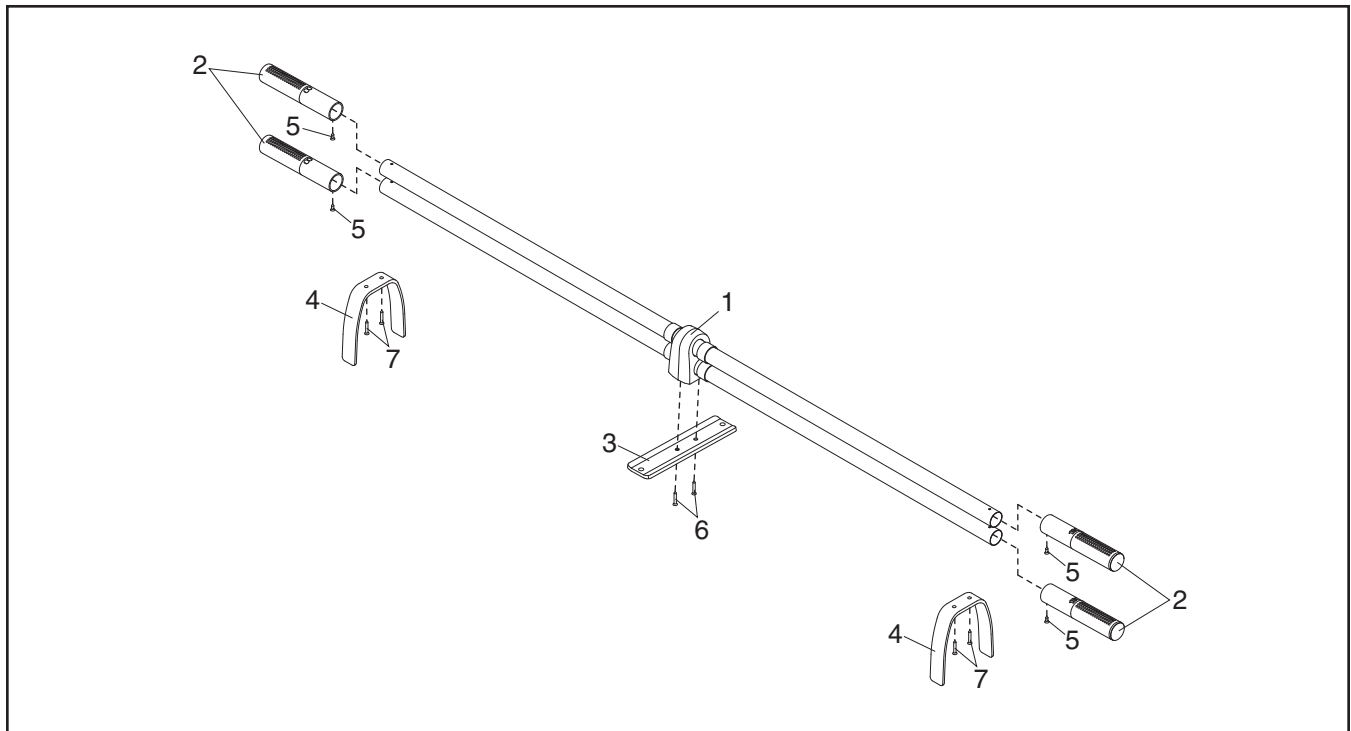

---

## ORDERING REPLACEMENT PARTS

To order replacement parts, see the front cover of this manual. To help us assist you, please be prepared to give the following information:

- the MODEL NUMBER of the product (WEMC0942.1)
- the NAME of the product (MAX by WEIDER resistance system MAX PACK accessory)
- the SERIAL NUMBER of the product (see the front cover of this manual)
- the KEY NUMBER and DESCRIPTION of the part(s) (see the PART LIST and EXPLODED DRAWING on page 6 of this manual)

---

## LIMITED WARRANTY

ICON Health & Fitness, Inc. (ICON), warrants this product to be free from defects in workmanship and material, under normal use and service conditions. ICON warrants the resistance bars for the lifetime of the product, and all other parts for five (5) years. This warranty extends only to the original purchaser. ICON's obligation under this warranty is limited to replacing or repairing, at ICON's option, the product through one of its authorized service centers. All repairs for which warranty claims are made must be pre-authorized by ICON. If the product is shipped to a service center, freight charges to and from the service center will be the customer's responsibility. For in-home service, the customer will be responsible for a minimal trip charge. This warranty does not extend to any product or damage to a product caused by or attributable to freight damage, abuse, misuse, improper or abnormal usage or repairs not provided by an ICON authorized service center; products used for commercial or rental purposes; or products used as store display models. No other warranty beyond that specifically set forth above is authorized by ICON.

ICON is not responsible or liable for indirect, special or consequential damages arising out of or in connection with the use or performance of the product or damages with respect to any economic loss, loss of property, loss of revenues or profits, loss of enjoyment or use, costs of removal or installation or other consequential damages of whatsoever nature. Some states do not allow the exclusion or limitation of incidental or consequential damages. Accordingly, the above limitation may not apply to you.

The warranty extended hereunder is in lieu of any and all other warranties and any implied warranties of merchantability or fitness for a particular purpose is limited in its scope and duration to the terms set forth herein. Some states do not allow limitations on how long an implied warranty lasts. Accordingly, the above limitation may not apply to you.

This warranty gives you specific legal rights. You may also have other rights which vary from state to state.

**ICON HEALTH & FITNESS, INC., 1500 S. 1000 W., LOGAN, UT 84321-9813**