

CLUB WEIDER[®] 550

Model No. WEBE29300

Serial No. _____

Write the serial number in the space above for reference.

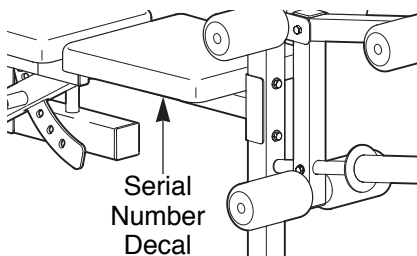

USER'S MANUAL

QUESTIONS?

As a manufacturer, we are committed to providing complete customer satisfaction. If you have questions, or if there are missing parts, we will guarantee complete satisfaction through direct assistance from our factory.

TO AVOID UNNECESSARY DELAYS, PLEASE CALL DIRECT TO OUR TOLL-FREE CUSTOMER HOT LINE. The trained technicians on our customer hot line will provide immediate assistance, free of charge to you.

CUSTOMER HOT LINE:

1-800-999-3756

Mon.-Fri., 6 a.m.-6 p.m. MST

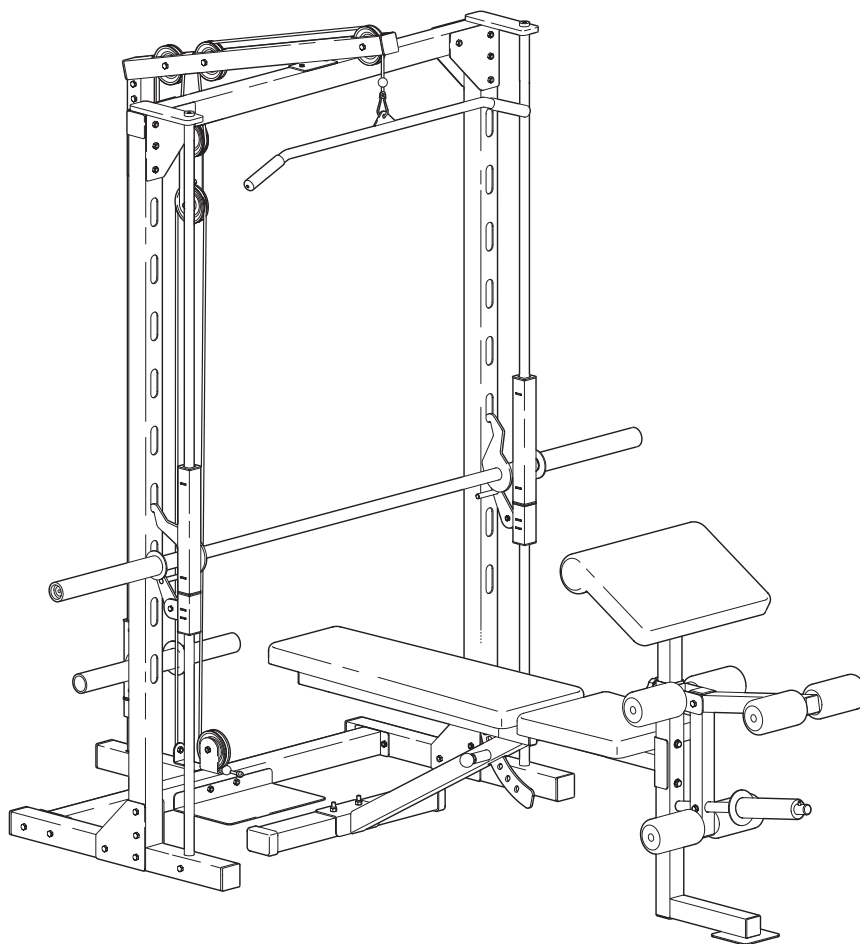

CAUTION

Read all precautions and instructions in this manual before using this equipment. Save this manual for future reference.



Visit our website at

www.weiderfitness.com

new products, prizes,
fitness tips, and much more!

Table of Contents

Warning Decal Placement	2
Important Precautions	3
Before You Begin	4
Part Identification Chart	5
Assembly	6
Adjusting the Weight Bench	15
Exercise Guidelines	18
Ordering Replacement Parts	Back Cover
Limited Warranty	Back Cover

Note: A Part List/Exploded Drawing is attached in the center of this manual. Remove the Part List/Exploded Drawing before beginning assembly.

Warning Decal Placement

The decals shown at the right have been placed on the weight bench in the indicated locations. If one or both of the decals are missing or illegible, please call our Customer Service Department toll-free at 1-800-999-3756, Monday through Friday, 6 a.m. until 6 p.m. Mountain Time, to order a free replacement decal. Apply the replacement decal in the location shown.

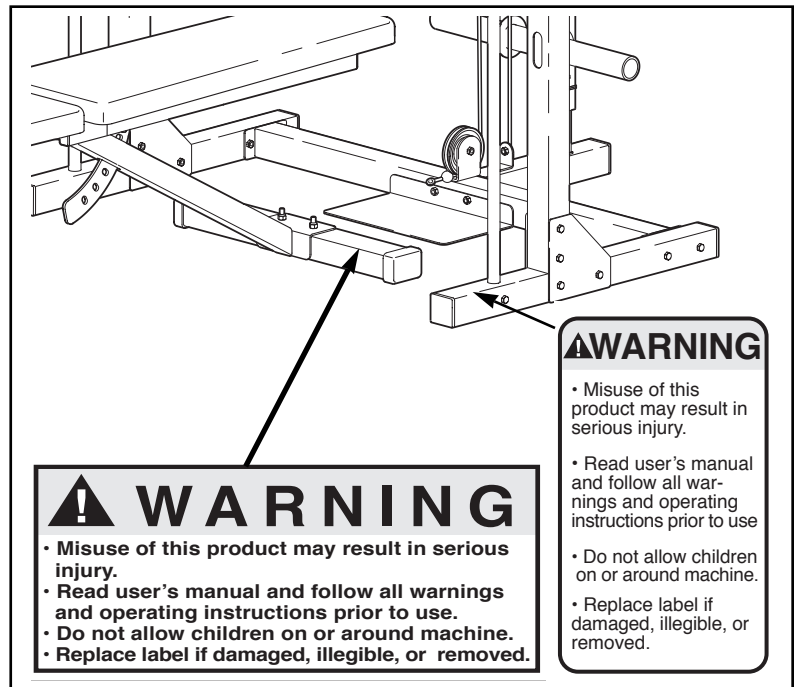

Important Precautions

⚠ WARNING: To reduce the risk of serious injury, read the following important precautions before using the weight rack.

1. Read all instructions in this manual before using the weight rack. Use the weight rack only as described in this manual.
2. It is the responsibility of the owner to ensure that all users of the weight rack are adequately informed of all precautions.
3. The weight rack is intended for home use only. Do not use the weight rack in a commercial, rental or institutional setting.
4. Use the weight rack only on a level surface. Cover the floor beneath the weight rack for protection.
5. Inspect and tighten all parts each time you use the weight rack. Replace any worn parts immediately.
6. Keep children under 12 and pets away from the weight rack at all times.
7. Keep hands and feet away from moving parts.
8. Always wear athletic shoes for foot protection while exercising.
9. Always make sure there is an equal amount of weight (not included) on each side of the barbell or the weight carriage.
10. The weight rack is designed to support a maximum of 300 pounds, including the barbell and weights (weights are not included). Do not place more than 300 pounds, including the barbell, on the weight gliders and safety spotters. Do not place more than 150 pounds on the weight carriage.
11. Always set both weight gliders and both safety spotters at the same height.
12. Always secure your weights (not included) with weight clips when they are mounted on the barbell or the weight carriage.
13. Always lower the weight carriage in a controlled manner; never let the weight carriage drop.
14. Always move your bench out of the way when performing an exercise that does not use the bench.
15. Always remove the lat bar when performing an exercise that does not require the use of the lat bar.
16. If you feel pain or dizziness at any time while exercising, stop immediately and begin cooling down.

⚠ WARNING: Before beginning this or any exercise program, consult your physician. This is especially important for persons over the age of 35 or persons with pre-existing health problems. Read all instructions before using. ICON assumes no responsibility for personal injury or property damage sustained by or through the use of this product.

Before You Begin

Thank you for selecting the versatile CLUB WEIDER® 550 weight bench. The 550 weight bench is designed to help you develop every major muscle group of the body. Whether your goal is a shapely figure, dramatic increase in muscle size and strength, or a healthier cardiovascular system, the 550 weight bench will help you achieve the specific results you want.

For your benefit, read this manual carefully before using the 550 weight bench. If you have additional questions, please call our Customer Service

Department toll-free at 1-800-999-3756, Monday through Friday, 6 a.m. until 6 p.m. Mountain Time (excluding holidays). To help us assist you, please note the product model number and serial number before calling. The model number is WEBE29300. The serial number can be found on a decal attached to the weight bench (see the front cover of this manual).

Before reading further, please review the drawing below and familiarize yourself with the parts that are labeled.

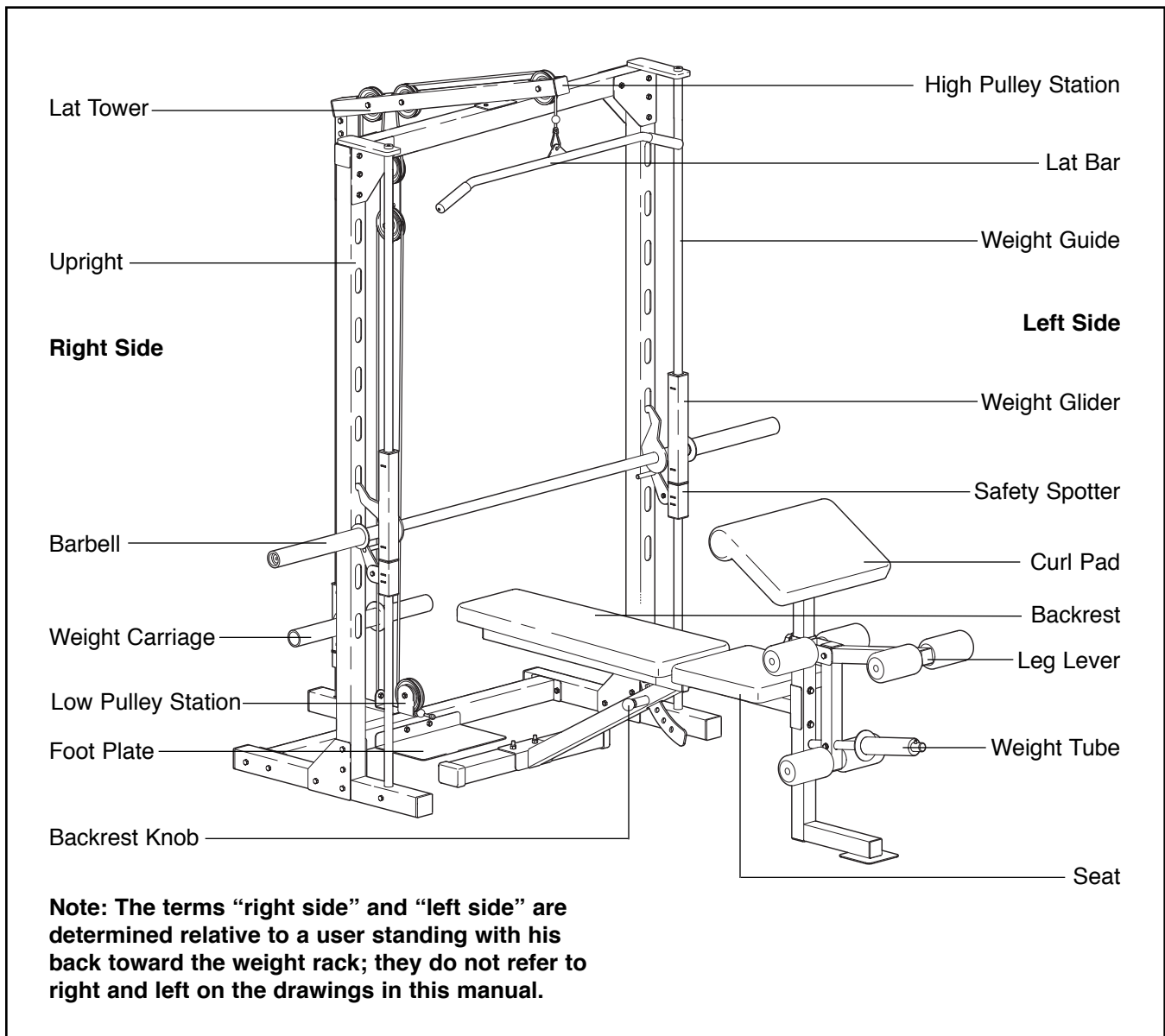

Part Identification Chart—Model No. WEBE29300

R0800A

Refer to the drawings below to identify small parts used in assembly. The number in parentheses below each drawing is the key number of the part, from the Part List in the center of this manual. The number following the key number is the quantity needed for assembly. **Note: Some small parts may have been pre-attached. If a part is not in the parts bag, check to see if it has been pre-attached.**

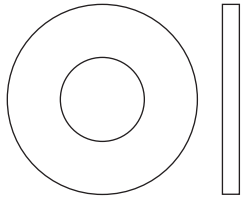

M10 Large Washer (58)—6

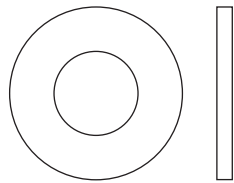

M10 Small Washer (6)—18

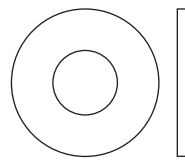

M8 Flat Washer (67)—2

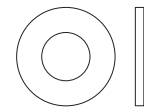

M6 Washer (81)—4

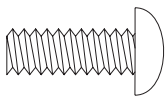

M6 x 16mm Screw (61)—6

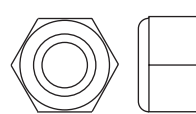

M8 Nylon Locknut (54)—4

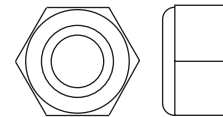

M10 Nylon Locknut (11)—46

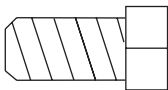

M8 x 16mm Screw (50)—2

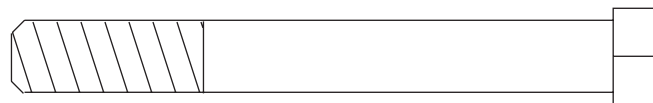

M10 x 80mm Bolt (41)—24

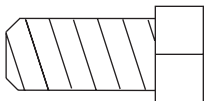

M10 x 20mm Bolt (26)—2



M10 x 75mm Bolt (39)—2

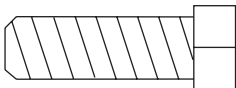

M8 x 25mm Bolt (53)—2



M10 x 70mm Bolt (85)—1

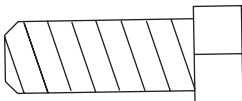

M10 x 25mm Bolt (43)—4

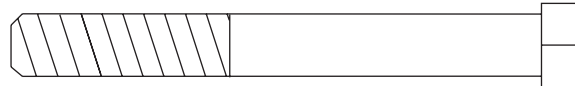

M8 x 70mm Bolt (30)—1

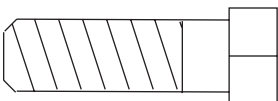

M10 x 30mm Bolt (38)—2

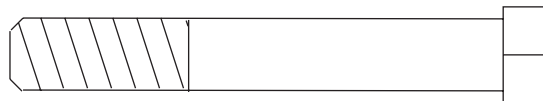

M10 x 65mm Bolt (56)—9

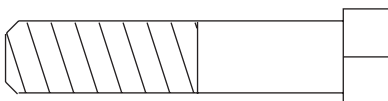

M10 x 45mm Bolt (40)—3

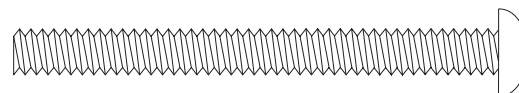

M6 x 65mm Screw (62)—4



M8 x 55mm Bolt (70)—1

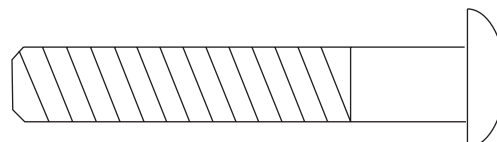

M10 x 60mm Carriage Bolt (64)—2

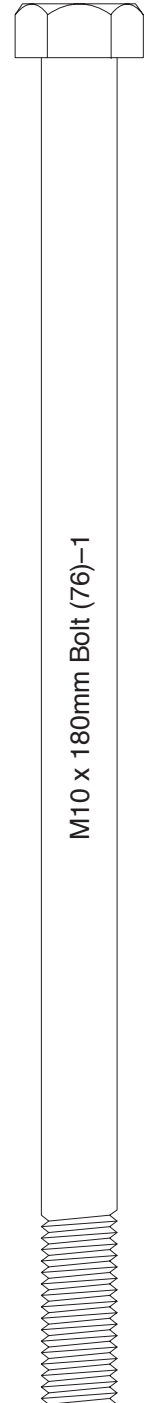

M10 x 180mm Bolt (76)—1

Assembly

Before beginning assembly, carefully read the following information and instructions:

Make Things Easier for Yourself!





This manual is designed to ensure that the weight bench can be assembled successfully by anyone. By setting aside plenty of time, and by deciding to make the task enjoyable, assembly will go smoothly.

- Assembly requires two people.
- Place all parts in a cleared area and remove the packing materials. Do not dispose of the packing materials until assembly is completed.
- Tighten all parts as you assemble them, unless instructed to do otherwise.
- For help identifying small parts, use the PART IDENTIFICATION CHART on page 5. **Note:**

Some small parts may be pre-assembled.

- As you assemble the weight bench, make sure all parts are oriented as shown in the drawings.

Assembly requires the following tools (not included):

- **Two adjustable wrenches** 
- **One rubber mallet** 
- **One standard screwdriver** 
- **One phillips screwdriver** 
- **Lubricant, such as grease or petroleum jelly, and soapy water.**

Assembly will be more convenient if you have a socket set, a set of open-end or closed-end wrenches, or a set of ratchet wrenches.

1. **Before beginning, make sure you understand the information in the box above. Note: Some parts described in the assembly steps may be pre-assembled.**

Press a 60mm Square Inner Cap (55) into each end of a Base (7). Attach the Base to the indicated end of the Base Crossbar (20) using a Support Plate (57), two M10 x 80mm Bolts (41), and two M10 Nylon Locknuts (11).

Attach the other Base (7) to the opposite side of the Base Crossbar (20) in the same manner.

2. Press a 60mm Square Inner Cap (55) into the end of the Rear Base (3). Attach the Rear Base and the Foot Plate (4) to the Base Crossbar (20) using two M10 x 80 mm Bolts (41) and two M10 Nylon Locknuts (11). **Do not tighten the Nylon Locknuts yet.**

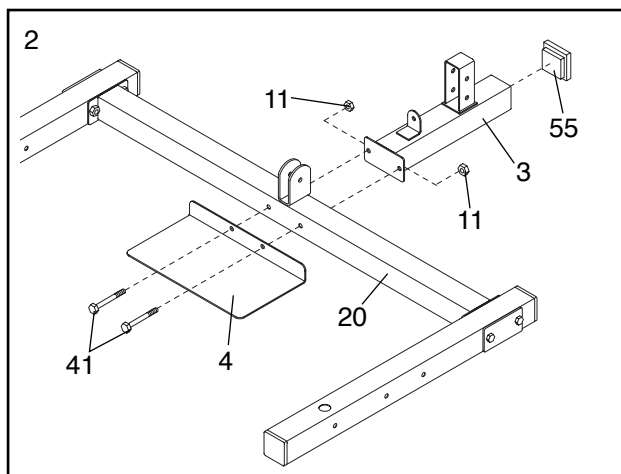
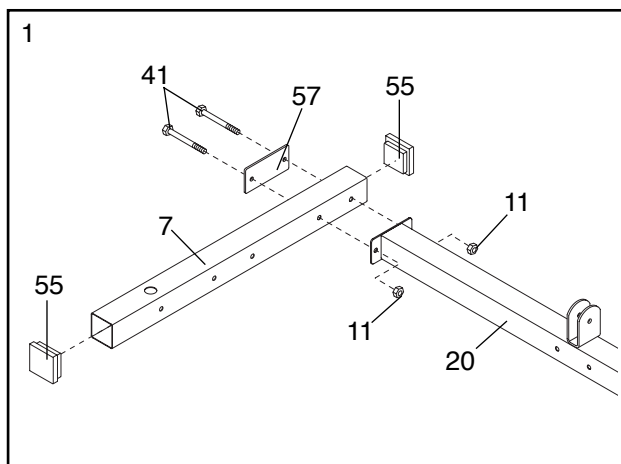

3. Attach an Upright (1) to each Base (7) using two Joint Plates (12), four M10 x 80mm Bolts (41), and four M10 Nylon Locknuts (11). Make sure the Uprights are oriented exactly as shown. **Do not tighten the Nylon Locknuts yet.**

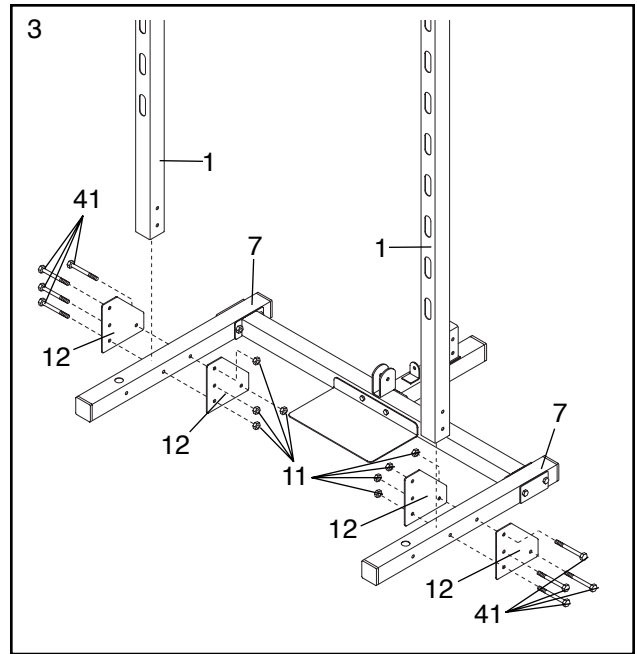

4. Insert a Weight Guide (18) into the indicated hole in each Base (7). Attach the Weight Guides to the Bases using M10 x 75mm Bolts (39), M10 Small Washers (6), and M10 Nylon Locknuts (11). **Do not tighten the Nylon Locknuts yet.**

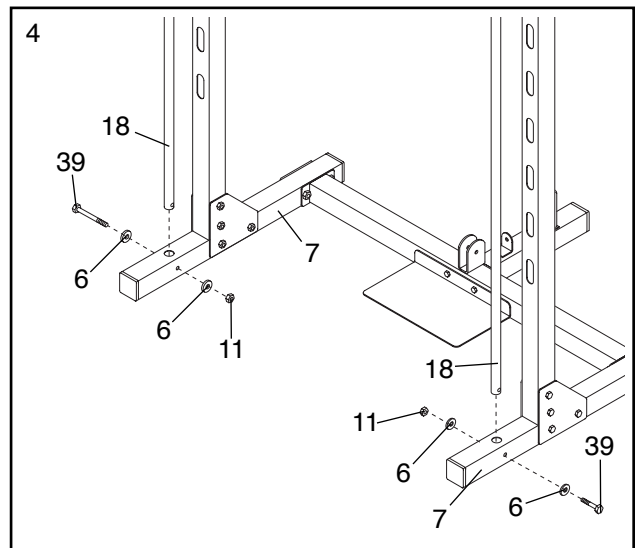

5. Press a 25mm Bushing (48) into each end of the Locking Bar (34). Slide the Barbell (35) into the Locking Bar (34).

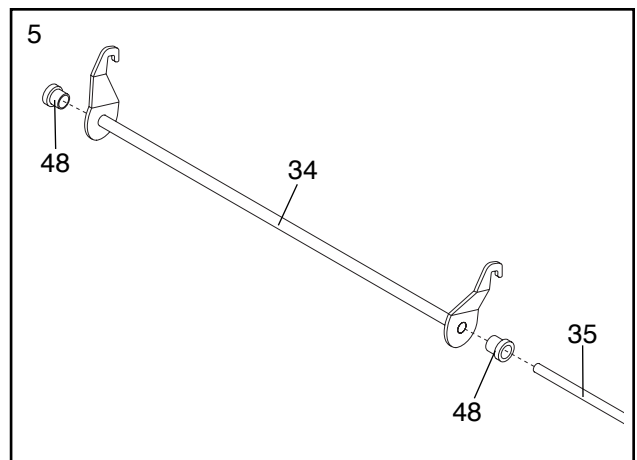

6. Press a 38mm Bushing (29) into each end of the Right Weight Glider (31). Slide the Right Weight Glider onto the indicated end of the Barbell (35) and attach it to the Barbell using an M8 x 16mm Screw (50). **Do not tighten the Screw yet. Make sure the Right Weight Glider is oriented exactly as shown.**

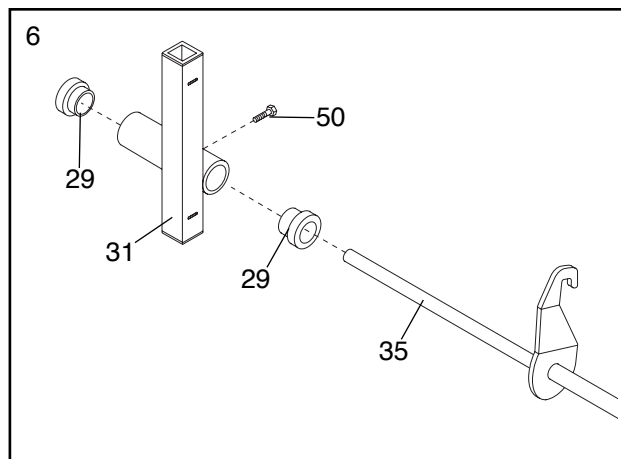

7. Press a 38mm Bushing (29) into each end of the Left Weight Glider (32). Slide the Left Weight Glider onto the indicated end of the Barbell (35) and secure it to the Barbell using an M8 x 16mm Screw (50). **Do not tighten the Screw yet. Make sure the Left Weight Glider is oriented exactly as shown.**

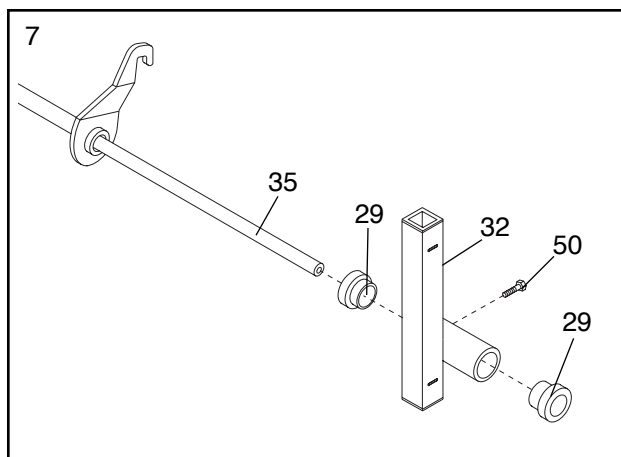

8. Press a 50mm Bushing (47) into the indicated end of a Weight Adapter (33). Slide the Weight Adapter onto the Barbell (35) and secure it to the Barbell using a Large Washer (44) and an M10 x 25mm Bolt (43).

Attach the other Weight Adapter (33) to the other end of the Barbell (35) in the same manner.

Tighten the M8 x 16mm Screws (50) used in steps 6 and 7.

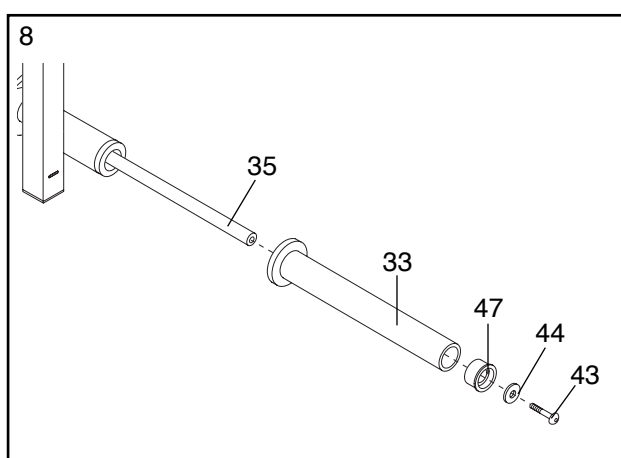

9. **Note: This step requires the help of a second person.**

Slide the Right Safety Spotter (23) and the Left Safety Spotter (24) onto the Weight Guides (18). **Make sure the Safety Spotters are oriented exactly as shown.**

Slide the assembled Locking Bar (34) and the Right and Left Weight Gliders (31, 32) onto the Weight Guides (18). **Make sure the Locking Bar and Weight Gliders are oriented exactly as shown.**

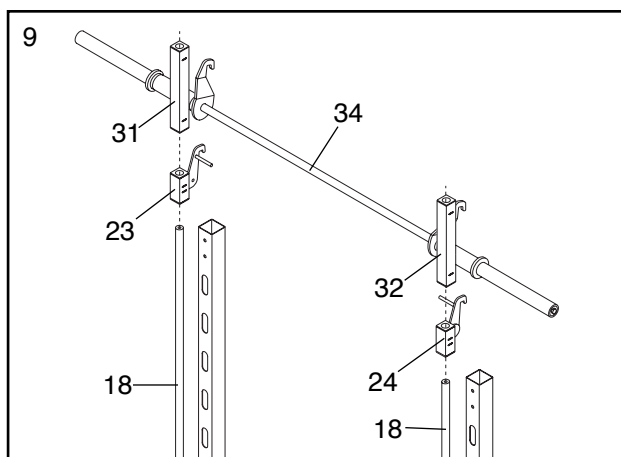

10. Press a 60mm Square Inner Cap (55) into each end of the Top Crossbar (9). Attach the Top Crossbar to the Uprights (1) using four Joint Plates (12), eight M10 x 80mm Bolts (41), and eight M10 Nylon Locknuts (11). **Do not tighten the Nylon Locknuts yet.**

Secure the Top Crossbar (9) to the Weight Guides (18) using two M10 x 30mm Bolts (38) and two M10 Small Washers (6).

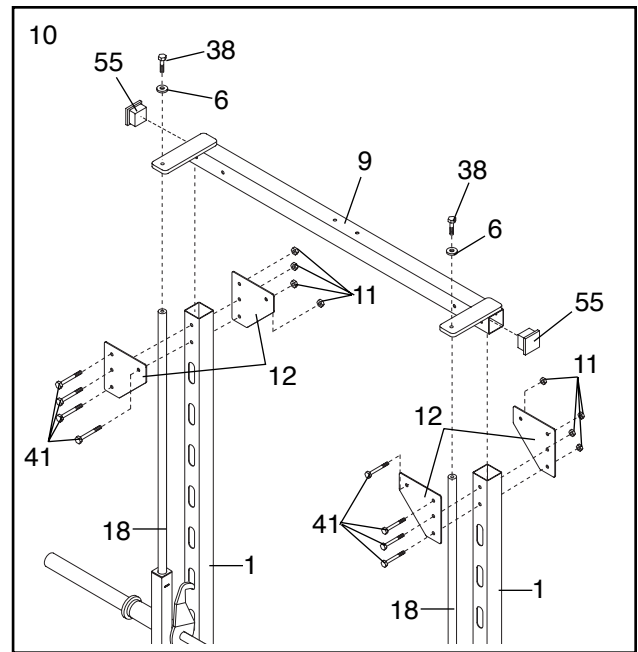

11. Press Carriage Bushings (27) into the ends of the Weight Carriage (22). Press 50mm Round Inner Caps (25) into the ends of the weight tube on the Weight Carriage.

Insert an M10 x 20mm Bolt (26) into the bracket on the Weight Carriage (22).

Slide the Weight Carriage (22) onto the Rear Upright (2) as shown. **Make sure that the Weight Carriage and the Rear Upright are oriented as shown.**

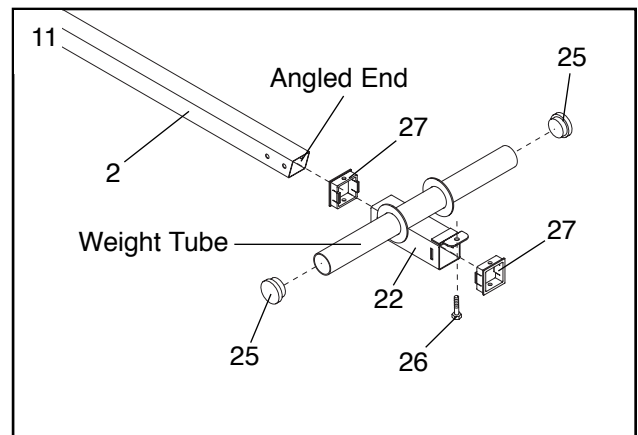

12. Refer to the inset drawing. Press a Carriage Bushing (27) into the top of the Carriage Stop (28) as shown.

Slide the Carriage Stop (28) onto the lower end of the Rear Upright (2). Attach the Carriage Stop to the Rear Upright with an M8 x 70mm Bolt (30) and an M8 Nylon Locknut (54).

Slide the Rear Upright (2) onto the bracket on the Rear Base (3). Attach the Rear Upright to the Rear Base using two M10 x 65mm Bolts (56), four M10 Small Washers (6), and two M10 Nylon Locknuts (11). **Do not tighten the Nylon Locknuts yet.**

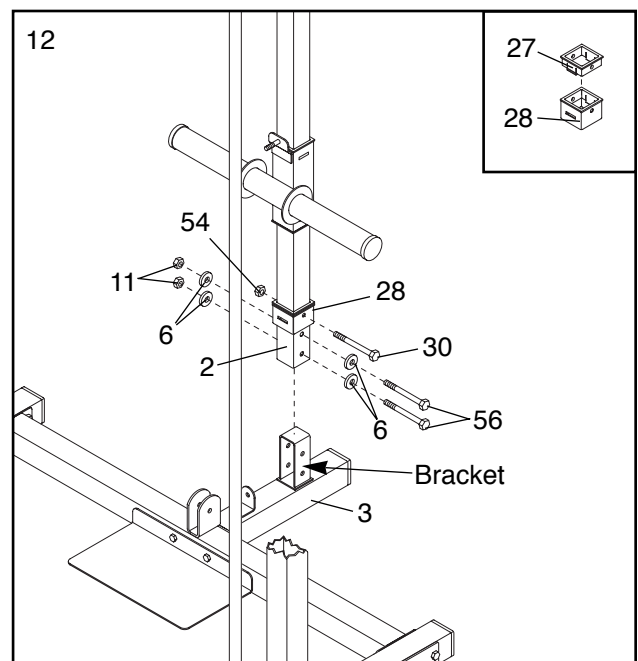

13. Press a 50mm Square Inner Cap (10) into each end of the Pulley Bar (59). Slide the bracket on the Pulley Bar into the top of the Rear Upright (2). Attach the Pulley Bar to the Rear Upright using two M10 x 65mm Bolts (56), four M10 Small Washers (6), and two M10 Nylon Locknuts (11).

Attach the Pulley Bar (59) to the Top Crossbar (9) using a Support Plate (57), two M10 x 80mm Bolts (41), and two M10 Nylon Locknuts (11).

Tighten all Nylon Locknuts used in steps 1 through 13.

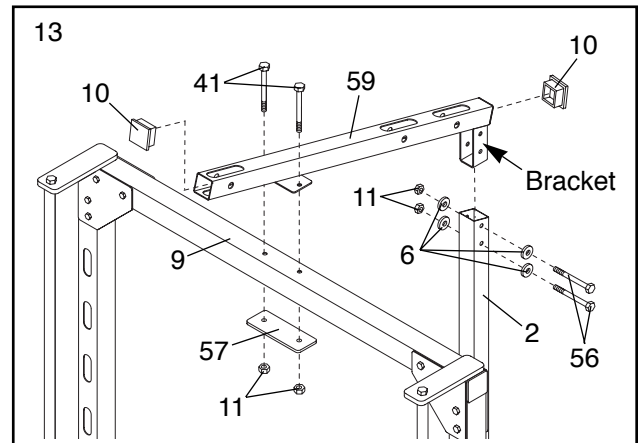

14. Identify the High Cable (13), which is the shorter of the two Cables. Route the High Cable up through the indicated slot in the Pulley Bar (59). Make sure the ball is in the indicated location.

Route the High Cable (13) around a Pulley (5) as shown. Attach the Pulley inside the slot in the Pulley Bar (59) using an M10 x 65mm Bolt (56), two M10 Large Washers (58), two Pulley Spacers (15), and an M10 Nylon Locknut (11). **Do not overtighten the Nylon Locknut; the Pulley must be able to turn freely.**

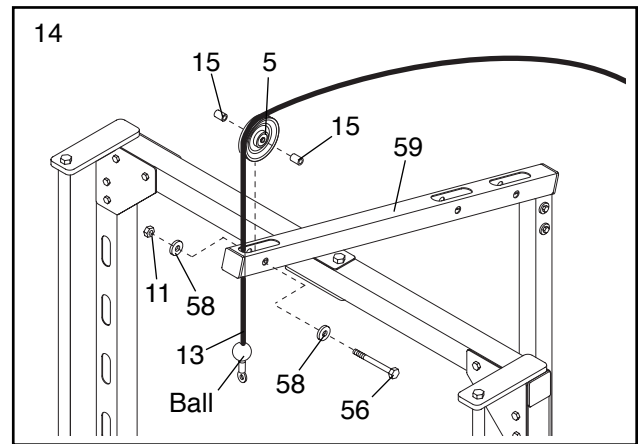

15. Route the High Cable (13) around another Pulley (5) and through the indicated slot in the Pulley Bar (59) as shown. Attach the Pulley inside the slot using an M10 x 65mm Bolt (56), two M10 Large Washers (58), two Pulley Spacers (15), and an M10 Nylon Locknut (11). **Do not overtighten the Nylon Locknut; the Pulley must be able to turn freely.**

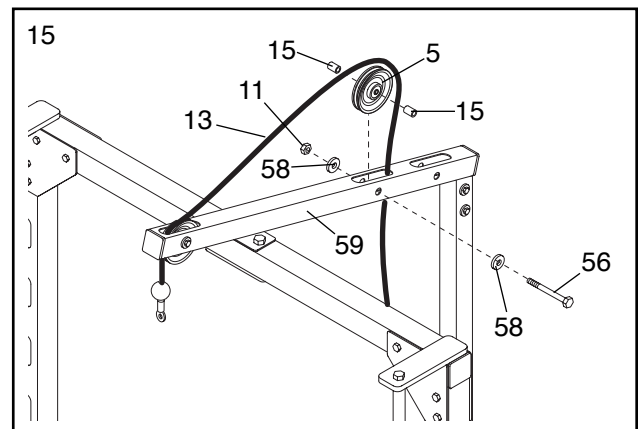

16. Route the High Cable (13) up through the Pulley Bar (59) and around another Pulley (5) as shown. Attach the Pulley inside the slot in the Pulley Bar using an M10 x 65mm Bolt (56), two M10 Large Washers (58), two Pulley Spacers (15), and an M10 Nylon Locknut (11). **Do not overtighten the Nylon Locknut; the Pulley must be able to turn freely.**

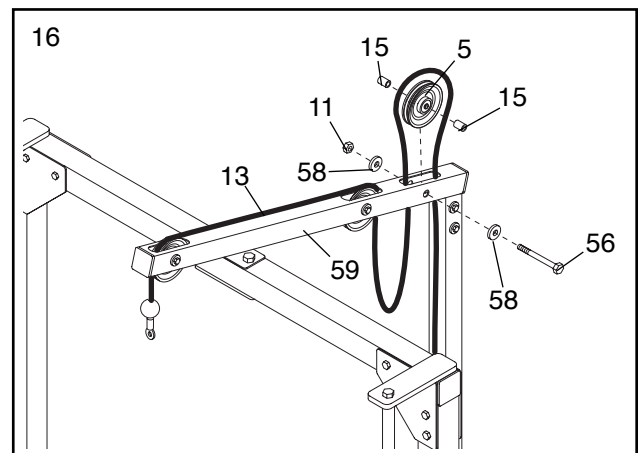

17. Slide the indicated end of the High Cable (13) onto the M10 x 20mm Bolt (26) in the Weight Carriage (22). Tighten an M10 Nylon Locknut (11) onto the Bolt.

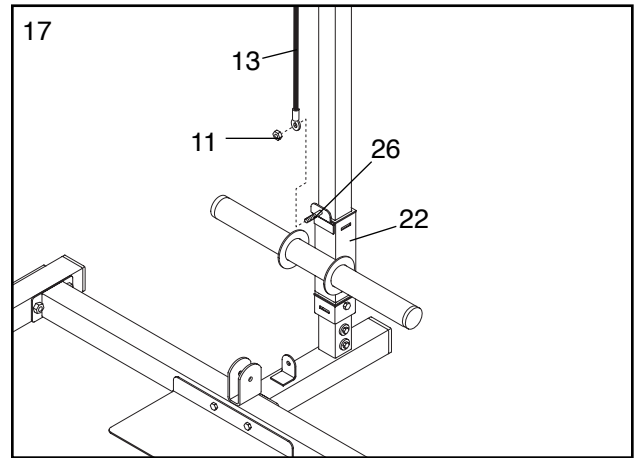

18. Route the High Cable (13) around a Pulley (5) as shown. Hold a Cable Trap (21) against the Pulley and attach a Pulley Plate (19) to each side of the Pulley using an M10 x 45mm Bolt (40) and an M10 Nylon Locknut (11). Make sure the Cable Trap holds the High Cable in the groove of the Pulley. **Do not overtighten the Nylon Locknut; the Pulley must be able to turn freely.**

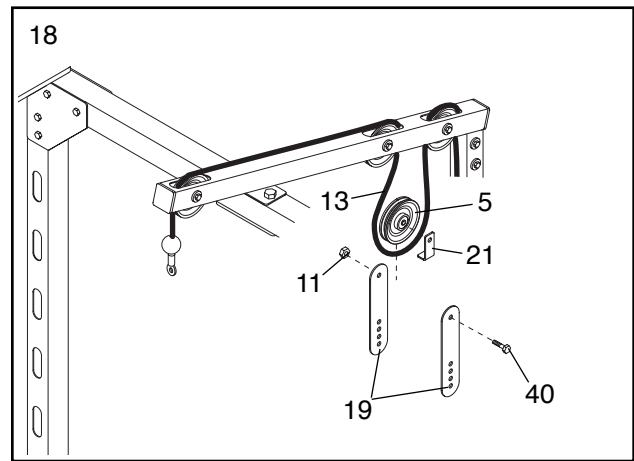

19. Route the indicated end of the Low Cable (8) around a Pulley (5). Attach the Pulley to the bracket on the Base Crossbar (20) using an M10 x 45mm Bolt (40) and an M10 Nylon Locknut (11). **Do not overtighten the Nylon Locknut; the Pulley must be able to turn freely.**

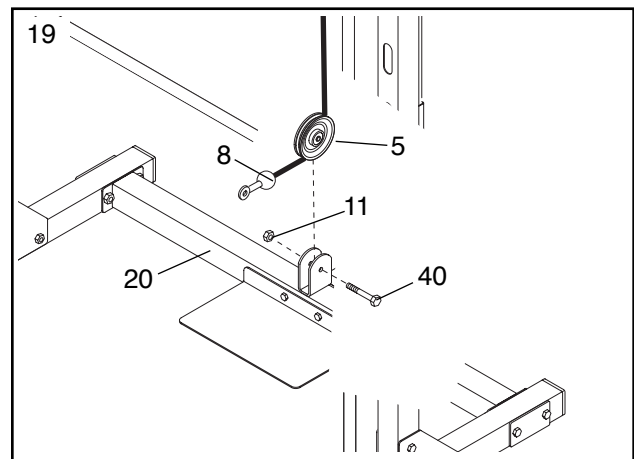

20. Route the Low Cable (8) around a Pulley (5) as shown. Hold a Cable Trap (21) against the Pulley and attach the Pulley and Cable Trap to the lowest holes in the two Pulley Plates (19) using an M10 x 45mm Bolt (40) and an M10 Nylon Locknut (11). Make sure the Cable Trap holds the Low Cable in the groove of the Pulley. **Do not overtighten the Nylon Locknut; the Pulley must be able to turn freely.**

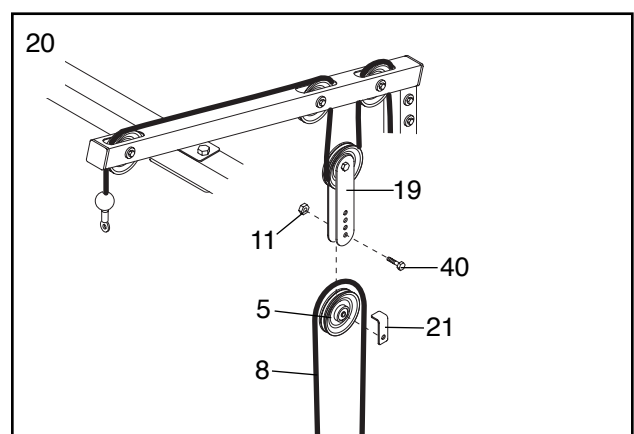

21. Attach the indicated end of the Low Cable (8) to the bracket on the Rear Base (3) using an M10 x 20mm Bolt (26) and an M10 Nylon Locknut (11).

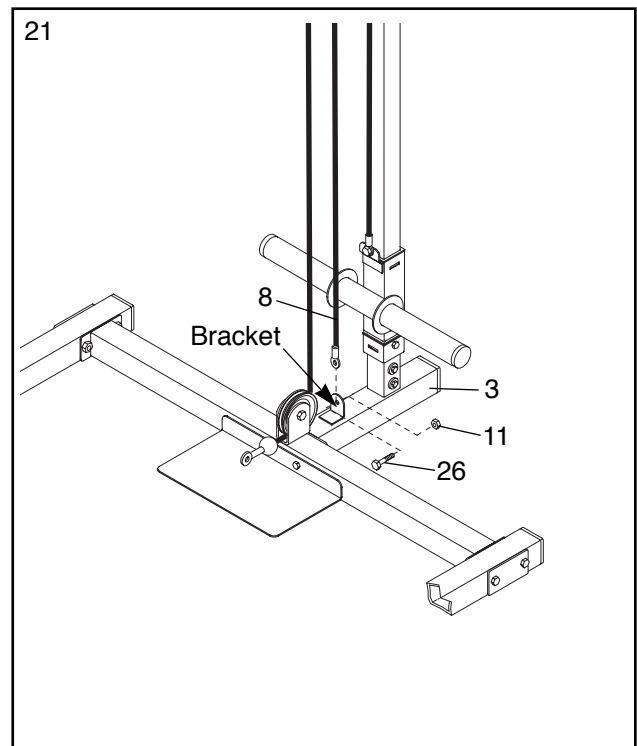

22. Press a 50mm Square Inner Cap (10) into the indicated end of the Front Leg (73). Insert a 50mm Square Inner Cap (10) into the bottom of the Front Leg.

Attach the Front Leg (73) to the Bench Frame (63) using two M10 x 65mm Bolts (56), two M10 Small Washers (6), and two M10 Nylon Locknuts (11).

Insert the Backrest Knob (80) into the Bench Frame (63) and tighten.

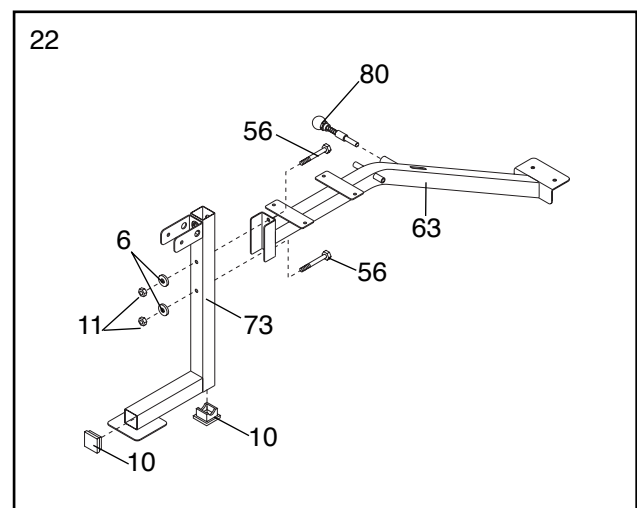

23. Press a 50mm x 70mm Outer Cap (60) onto each end of the Stabilizer (87). Attach the Stabilizer to the Bench Frame (63) using two M10 x 60mm Carriage Bolts (64) and two M10 Nylon Locknuts (11).

Note: The dents on the Stabilizer (87) should face the floor, and the decal should be in the indicated location.

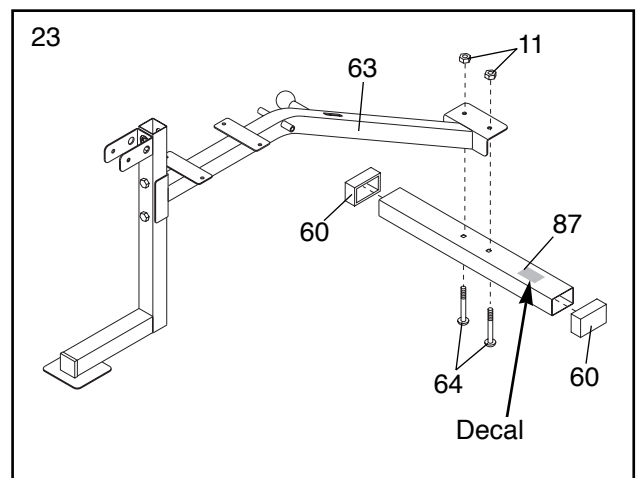

24. Press four 25mm x 50mm Inner Caps (79) into the ends of the Backrest Frame (78). Attach the Backrest Bracket (89) to the Backrest Frame using two M10 x 25mm Bolts (43) and two M10 Nylon Locknuts (11).

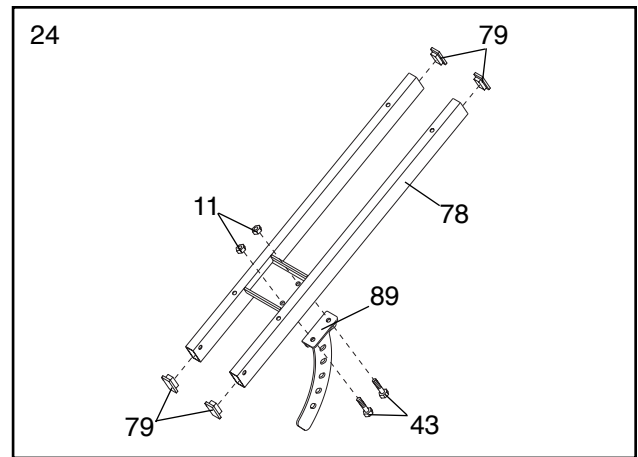

25. Attach the Backrest (69) to the Backrest Frame (78) with four M6 x 65mm Screws (62) and four M6 Washers (81). **Make sure that the Backrest is turned as shown.**

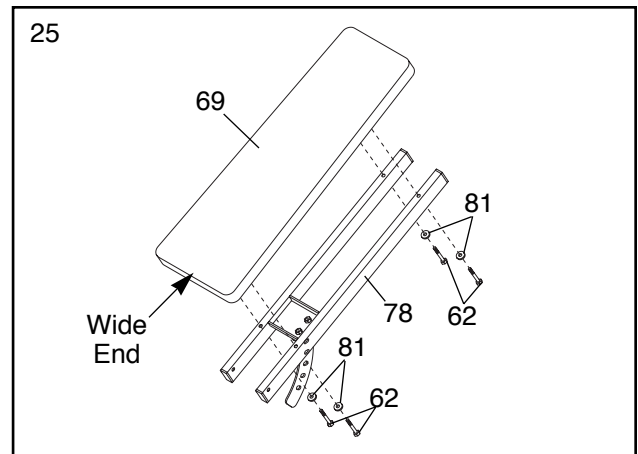

26. Lubricate an M10 x 180mm Bolt (76). Attach the Backrest Frame (78) to the Bench Frame (63) using the Bolt, two M10 Small Washers (6), and an M10 Nylon Locknut (11). Slide the Backrest Bracket (89) into the indicated slot on the Bench Frame. **Do not overtighten the Nylon Locknut; the Backrest must be able to pivot freely.**

To adjust the position of the Backrest, pull the Backrest Knob (80) outward and move the Backrest up or down. Slowly release the Backrest Knob, making sure that the pin on the Backrest Knob is inserted through one of the holes in the Backrest Bracket (89).

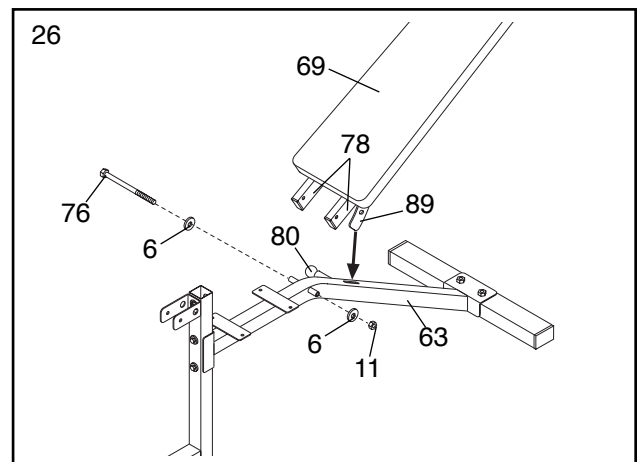

27. Attach the Seat (68) to the Bench Frame (63) with four M6 x 16mm Screws (61). **Make sure that the Seat is turned as shown.**

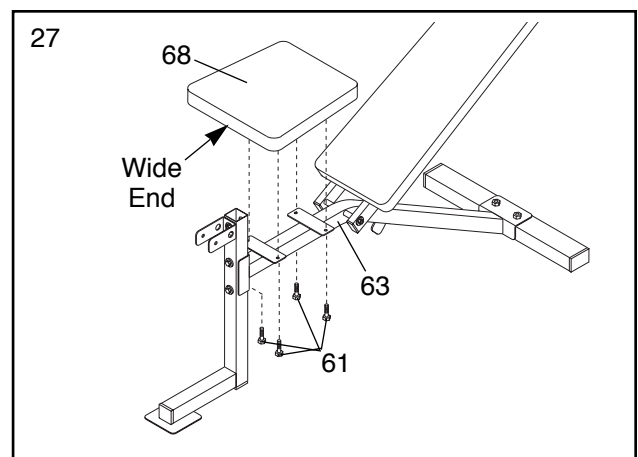

28. Press three 45mm Square Inner Caps (71) into the Leg Lever (72). Press a 25mm Round Inner Cap (84) into the indicated end of the Weight Tube (75).

Attach the Weight Tube (75) to the Leg Lever (72) with an M8 x 55mm Bolt (70), two M8 Flat Washers (67), a 10mm Spacer (74), and an M8 Nylon Locknut (54). Press an Angled Outer Cap (82) onto the back end of the Weight Tube.

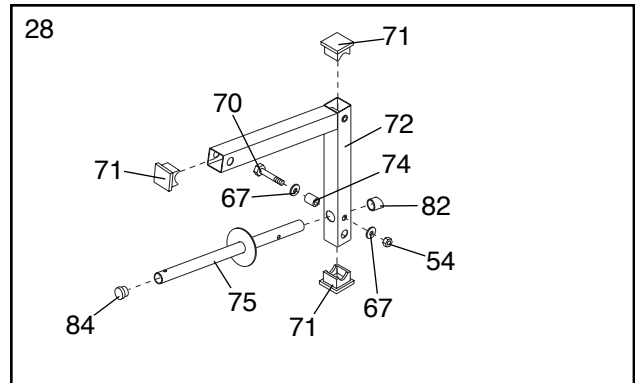

29. Lubricate an M10 x 70mm Bolt (85). Attach the Leg Lever (72) to the Front Leg (73) with the Bolt and an M10 Nylon Locknut (11). **Do not overtighten the Nylon Locknut; the Leg Lever must be able to pivot freely.**

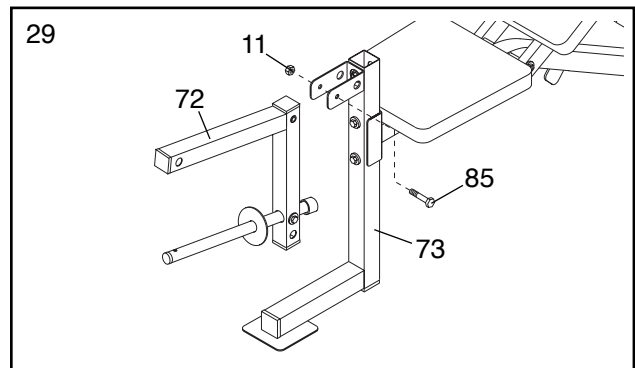

30. Press two 3/4" Round Inner Caps (66) into each of the three Pad Tubes (88). Slide the Pad Tubes through the indicated holes in the Front Leg (73) and the Leg Lever (72).

Slide two Foam Pads (65) onto each Pad Tube (88).

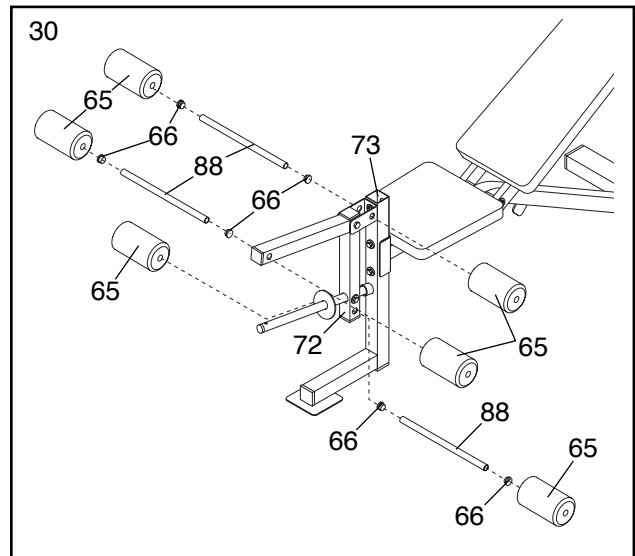

31. Attach the Curl Pad (77) to the Curl Post (83) with two M6 x 16mm Screws (61). Insert the Curl Post into the Front Leg (73) and secure it with the Curl Post Knob (86).

32. **Make sure all parts are properly tightened before you use the weight bench. The use of all remaining parts will be explained in Adjusting the Weight Bench, starting on page 15.**

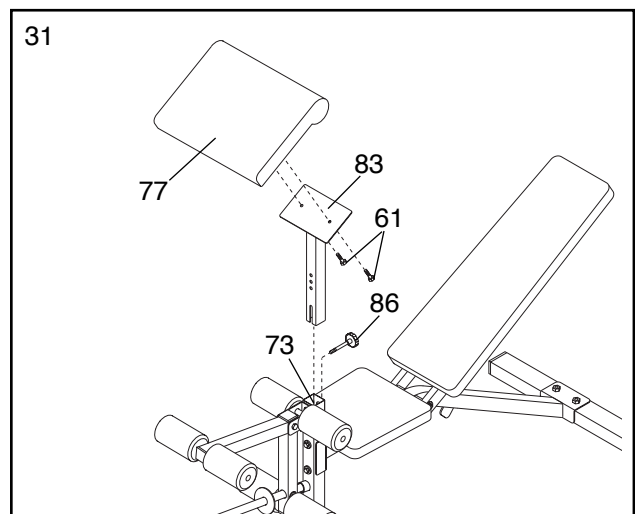

Adjusting the Weight Bench

This section explains how the weight bench can be adjusted. Inspect and tighten all parts each time you use the weight bench. Replace any worn parts immediately. The weight bench can be cleaned with a damp cloth and a mild, non-abrasive detergent. Do not use solvents.

USING THE LOCKING BAR

Before starting an exercise, position the barbell and the Safety Spotters (23, 24) in the correct position for the exercise.

To do this, stand in front of the rack and grip the Locking Bar (34) with both hands. Turn the Locking Bar until the two hooks disengage the slots in the Uprights (1). Raise or lower the Locking Bar to a new position and turn it until the hooks engage the slots in the Uprights. **Note: Always start an exercise with the barbell positioned at the lowest point to which it will move during the exercise.**

Position both Safety Spotters (23, 24) directly under the Weight Gliders (31, 32). (See USING THE SAFETY SPOTTERS below.)

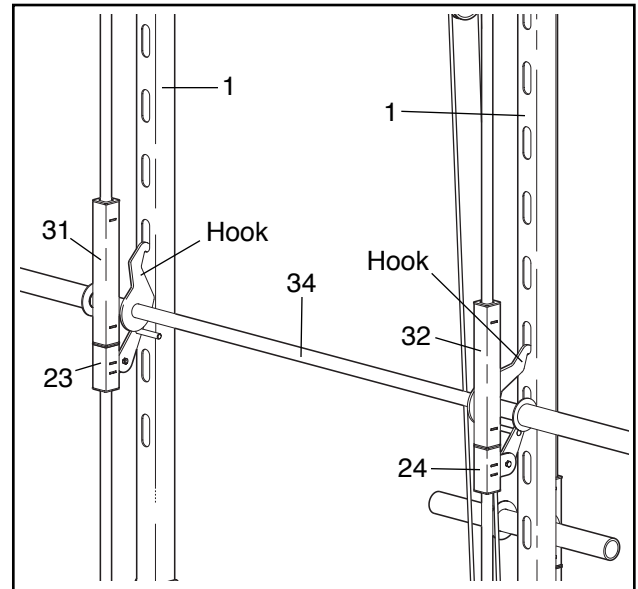

USING THE SAFETY SPOTTERS

To move the Safety Spotters (23, 24 [not shown]) to a new position, grip the handles on the spotter hooks and pull the hooks out of the slots in the Uprights (1). Raise or lower the Safety Spotters to new positions and pivot the hooks back into the slots in the Uprights.

WARNING: Always set both Safety Spotters (23, 24) at the same height.

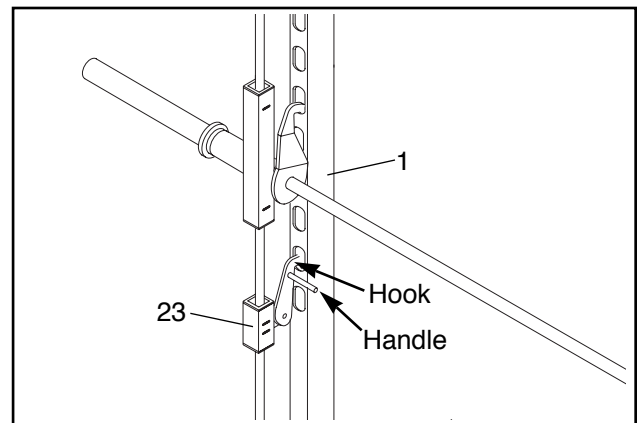

ATTACHING THE LAT BAR TO THE HIGH PULLEY STATION OR THE LOW PULLEY STATION

To use the high pulley station or the low pulley station, attach the Lat Bar (16) to the High Cable (13) or the Low Cable (8) (not shown) using a Cable Clip (14).

WARNING: Always remove the Lat Bar (16) when performing an exercise that does not require the use of the Lat Bar.

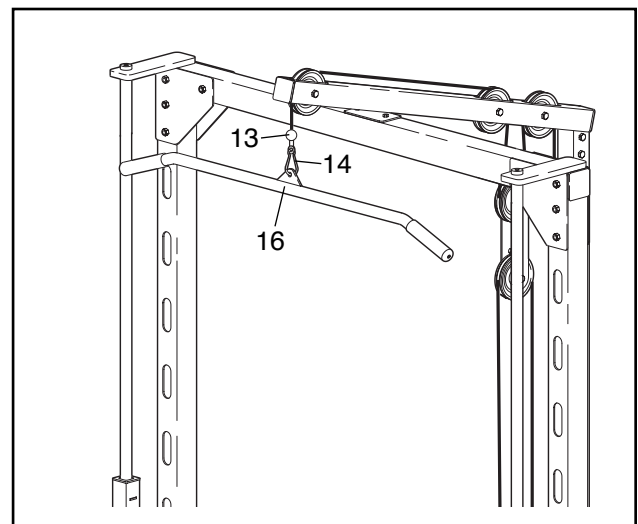

ATTACHING WEIGHTS TO THE BARBELL OR THE WEIGHT CARRIAGE

To use the Barbell (35), slide the desired amount of weight (not included) onto each end of the Barbell. Secure the weights with Weight Clips (51).

Weights can be attached to the weight tube on the Weight Carriage (22) in the same manner.

⚠ WARNING: Do not place more than 300 pounds on the Barbell (35). Do not place more than 150 pounds on the Weight Carriage (22). Always place the same amount of weight on each side of the Barbell or the Weight Carriage. Always secure weights with Weight Clips (51).

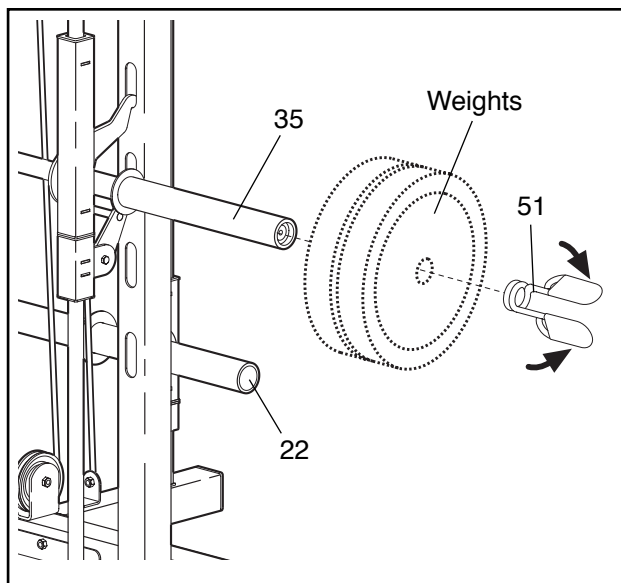

TIGHTENING THE CABLES

Woven cable, the type of cable used on the weight bench, can stretch slightly when it is first used. If the cables need to be tightened, remove the M10 Nylon Locknut (11) and the M10 x 45mm Bolt (40) from the lower ends of the Pulley Plates (19). Reattach the Pulley (5) and Cable Trap (21) to the next higher hole in the Pulley Plates. Make sure the Cable Trap holds the Low Cable (8) in the groove of the Pulley. Repeat until the cables are properly tightened. **Do not overtighten the Nylon Locknut; the Pulley must turn freely.**

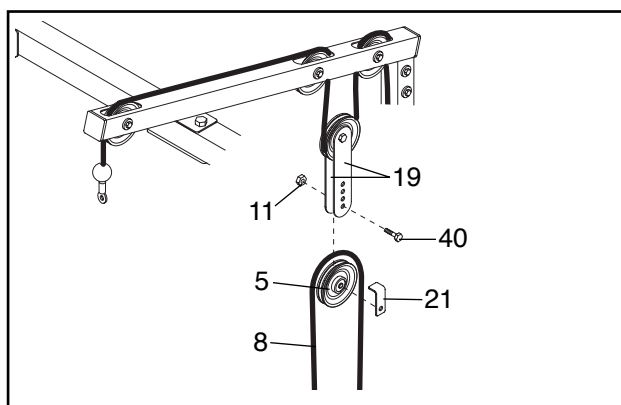

REMOVING THE FOAM PADS

For some exercises, the indicated Foam Pads (65) and Pad Tube (88) should be removed from the Front Leg (73). To do this, slide one of the Foam Pads off the Pad Tube, and then remove the Pad Tube.

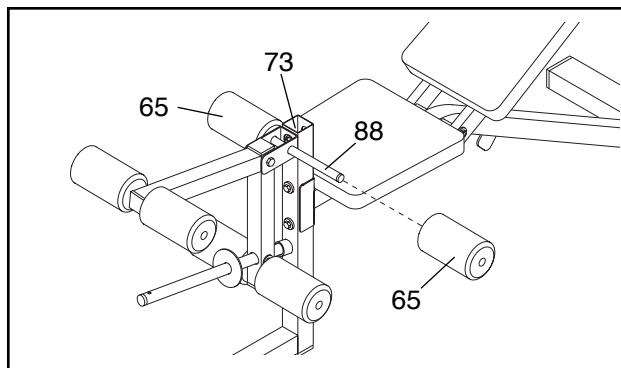

ATTACHING WEIGHTS TO THE LEG LEVER

To use the Leg Lever (72), slide the desired amount of weight onto the Weight Tube (75).

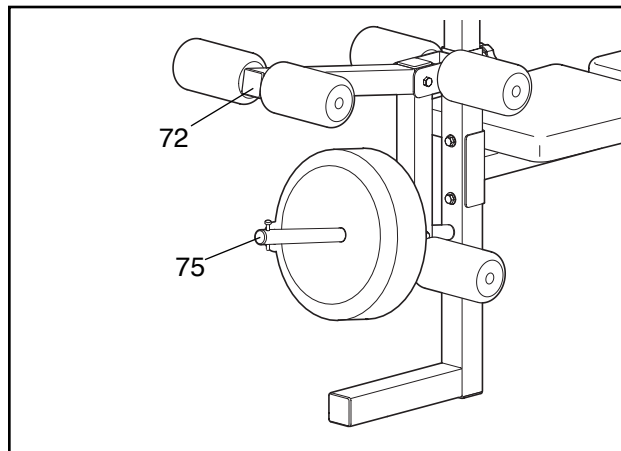

ATTACHING THE WEIGHT ADAPTER

To use your weight bench with an Olympic weight set, you must attach the Olympic Weight Adapter (42). To do this, press a Weight Adapter Bushing (46) into each end of the Weight Adapter. Slide the Weight Adapter onto the Weight Tube (75) and secure it with the Weight Adapter Pin (52).

⚠ WARNING: Do not place more than 150 pounds on the Weight Tube (75).

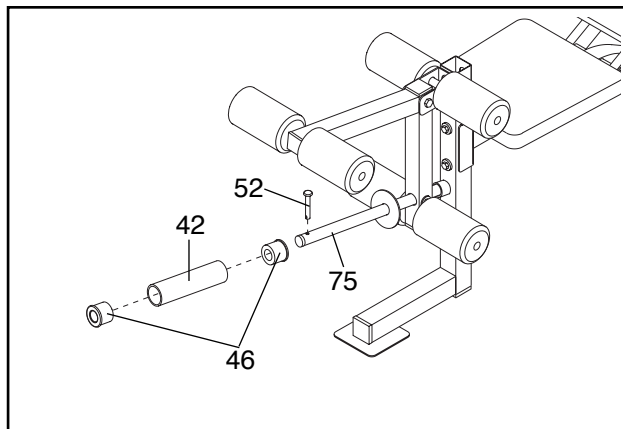

ATTACHING THE CURL PAD

For some exercises, the Curl Pad (77) must be attached to the weight bench.

Insert the Curl Post (83) into the indicated hole in the Front Leg (73). Align the holes in the Front Leg and the Curl Post. Secure the Curl Post with the Curl Post Knob (86). **Make sure that you fully tighten the Curl Post Knob.**

⚠ WARNING: When the Curl Pad (77) is not in use, store it away from the bench so it will not interfere with other exercises.

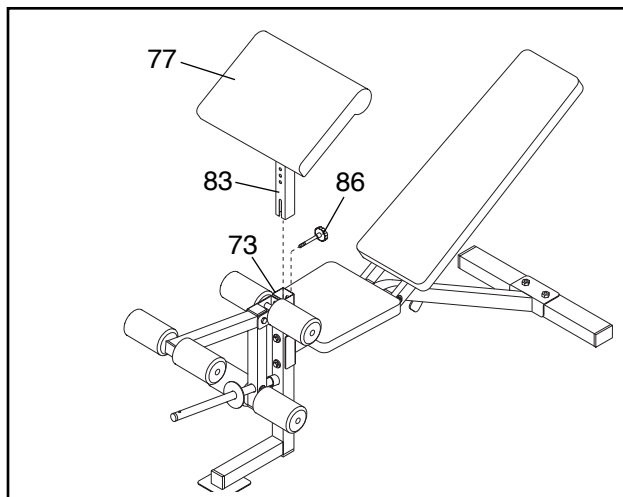

ADJUSTING THE BACKREST

The Backrest (69) can be adjusted to five positions. To adjust the Backrest, pull the Backrest Knob (80) outward and move the Backrest up or down. Slowly release the Backrest Knob, making sure the pin on the Backrest Knob is inserted through one of the holes in the Backrest Bracket (89).

⚠ WARNING: Make sure the Backrest Knob (80) is securely inserted into one of the holes in the Backrest Bracket (89) before putting any weight on the Backrest (69).

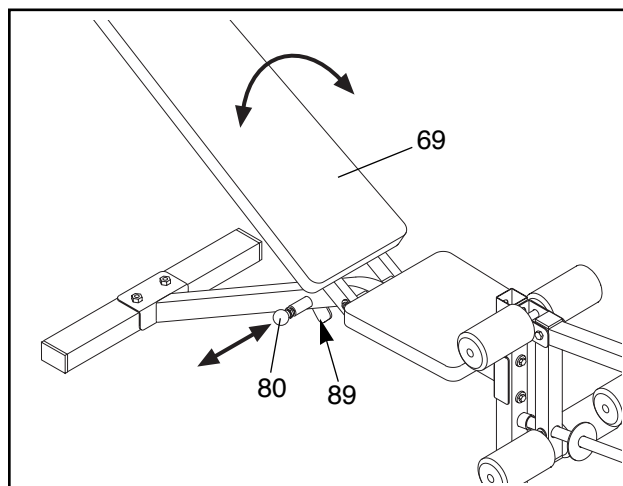

Exercise Guidelines

THE FOUR BASIC TYPES OF WORKOUTS

Muscle Building

The only way to increase the size and strength of your muscles is to push them to a high percentage of their capacity. As you progressively increase the intensity of your exercise, your muscles will continually adapt and grow. You can tailor each exercise to the proper intensity level in two ways:

- by changing the amount of weight used
- by changing the number of repetitions or sets performed (A “repetition” is one complete cycle of an exercise, such as one sit-up. A “set” is a series of repetitions).

The proper amount of weight for each exercise depends upon the individual user. You must gauge your limits and select the amount of weight that is right for you. Begin with 3 sets of 8 repetitions for each exercise you perform. Rest for 3 minutes after each set. When you can complete 3 sets of 12 repetitions without difficulty, increase the amount of weight.

Toning

You can tone your muscles by pushing them to a moderate percentage of their capacity. Select a moderate amount of weight and increase the number of repetitions in each set. Complete as many sets of 15 to 20 repetitions as possible without discomfort. Rest for 1 minute after each set. Work your muscles by completing more sets rather than by using high amounts of weight.

Weight Loss

To lose weight, use a low amount of weight and increase the number of repetitions in each set. Exercise for 20 to 30 minutes, resting for a maximum of 30 seconds between sets.

Cross Training

Many people desire a complete and balanced fitness program. Cross training is an efficient way to accomplish this. One example of a balanced program is:

- Plan weight training workouts on Monday, Wednesday, and Friday.
- Plan 20 to 30 minutes of aerobic exercise, such as cycling or swimming, on Tuesday and Thursday.
- Rest from both weight training and aerobic exercise for at least one full day each week to give your body time to regenerate.

The combination of weight training and aerobic exercise will reshape and strengthen your body and develop your heart and lungs.

PERSONALIZING YOUR EXERCISE PROGRAM

Specifying the exact length of time for each workout, and the number of repetitions and sets for each exercise, is a highly individual matter. It is very important to avoid overdoing it during the first few months of your exercise program. You should progress at your own pace and be sensitive to your body’s signals. If you experience pain or dizziness at any time while exercising, stop immediately and begin cooling down. Find out what is wrong before continuing. Remember that adequate rest and a proper diet are important factors in any exercise program.

WARMING UP

Begin each workout with 5 to 10 minutes of stretching and light exercise to warm up. Warming up prepares your body for more strenuous exercise by increasing circulation, raising your body temperature and delivering more oxygen to your muscles.

WORKING OUT

Each workout should include 6 to 10 different exercises. Select exercises for every major muscle group with emphasis on the areas that you want to develop the most. To give balance and variety to your workouts, vary the exercises from session to session.

Schedule your workouts for the time of day when your energy level is the highest. Each workout should be followed by at least one day of rest. Once you find the schedule that is right for you, stick with it.

EXERCISE FORM

You will gain the greatest benefits from exercising by maintaining proper form. This requires moving through the full range of motion for each exercise and moving only the appropriate parts of the body. Exercising in an uncontrolled manner will leave you feeling exhausted.

The repetitions in each set should be performed smoothly and without pausing. The exertion stage of each repetition should last only about half as long as the return stage. Proper breathing is important. Exhale during the exertion stage of each repetition and inhale during the return stroke. Never hold your breath.

Make sure to rest for a short period of time after each set. The ideal resting periods are:

- Rest three minutes after each set for a muscle building workout.
- Rest one minute after each set for a toning workout.
- Rest 30 seconds after each set for a weight loss workout.

Plan to spend the first couple of weeks familiarizing yourself with the equipment and learning the proper form for each exercise.

COOLING DOWN

End each workout with 5 to 10 minutes of stretching. Include stretches for both your arms and legs. Move slowly as you stretch and do not bounce. Ease into

each stretch gradually and go only as far as you can without strain. Stretching at the end of each workout is very effective for increasing flexibility.

STAYING MOTIVATED

For motivation, keep a record of each workout. List the date, the exercises performed, the weight lifted, and the numbers of sets and repetitions completed. Record your weight and key body measurements at the end of every month.

Remember, the key to achieving the greatest results is to make exercise a regular and enjoyable part of your everyday life.

MUSCLE CHART

- A. Sternomastoid (neck)
- B. Pectoralis Major (chest)
- C. Biceps (front of arm)
- D. Obliques (waist)
- E. Brachioradials (forearm)
- F. Hip Flexors (upper thigh)
- G. Abductor (outer thigh)
- H. Quadriceps (front of thigh)
- I. Sartorius (front of thigh)
- J. Tibialis Anterior (front of calf)
- K. Soleus (front of calf)
- L. Rectus Abdominus (stomach)
- M. Adductor (inner thigh)
- N. Trapezius (upper back)
- O. Rhomboideus (upper back)
- P. Deltoid (shoulder)
- Q. Triceps (back of arm)
- R. Latissimus Dorsi (mid back)
- S. Spinae Erectors (lower back)
- T. Gluteus Medius (hip)
- U. Gluteus Maximus (buttocks)
- V. Hamstring (back of leg)
- W. Gastrocnemius (back of calf)

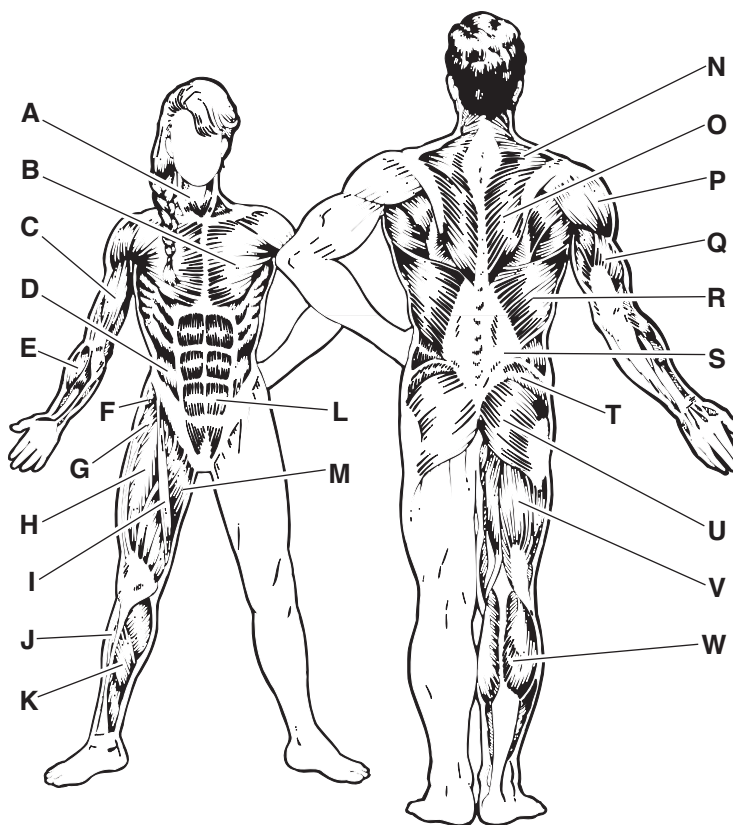

Ordering Replacement Parts

To order replacement parts, simply call our Customer Service Department toll-free at 1-800-999-3756, Monday through Friday, 6 a.m. until 6 p.m. Mountain Time (excluding holidays). To help us assist you, please be prepared to give the following information when calling:

- The MODEL NUMBER of the product (WEBE29300)
- The NAME of the product (CLUB WEIDER 550 weight bench)
- The SERIAL NUMBER of the product (see the front cover of this manual)
- The KEY NUMBER and DESCRIPTION of the desired part(s) (see the PART LIST and the EXPLODED DRAWING in the center of this manual).

Limited Warranty

ICON Health & Fitness, Inc. (ICON), warrants this product to be free from defects in workmanship and material, under normal use and service conditions, for a period of ninety (90) days from the date of purchase. This warranty extends only to the original purchaser. ICON's obligation under this warranty is limited to replacing or repairing, at ICON's option, the product at one of its authorized service centers. All products for which warranty claim is made must be received by ICON at one of its authorized service centers with all freight and other transportation charges prepaid, accompanied by sufficient proof of purchase. All returns must be pre-authorized by ICON. This warranty does not extend to any product or damage to a product caused by or attributable to freight damage, abuse, misuse, improper or abnormal usage or repairs not provided by an ICON authorized service center, products used for commercial or rental purposes, or products used as store display models. No other warranty beyond that specifically set forth above is authorized by ICON.

ICON is not responsible or liable for indirect, special or consequential damages arising out of or in connection with the use or performance of the product or damages with respect to any economic loss, loss of property, loss of revenues or profits, loss of enjoyment or use, costs of removal, installation or other consequential damages of whatsoever nature. Some states do not allow the exclusion or limitation of incidental or consequential damages. Accordingly, the above limitation may not apply to you.

The warranty extended hereunder is in lieu of any and all other warranties and any implied warranties of merchantability or fitness for a particular purpose is limited in its scope and duration to the terms set forth herein. Some states do not allow limitations on how long an implied warranty lasts. Accordingly, the above limitation may not apply to you.

This warranty gives you specific legal rights. You may also have other rights which vary from state to state.

ICON HEALTH & FITNESS, INC., 1500 S. 1000 W., LOGAN, UT 84321-9813

**REMOVE THIS PART LIST/EXPLODED DRAWING
FROM THE MANUAL**

**SAVE THIS PART LIST/EXPLODED DRAWING AND THE USER'S MANUAL
FOR FUTURE REFERENCE**

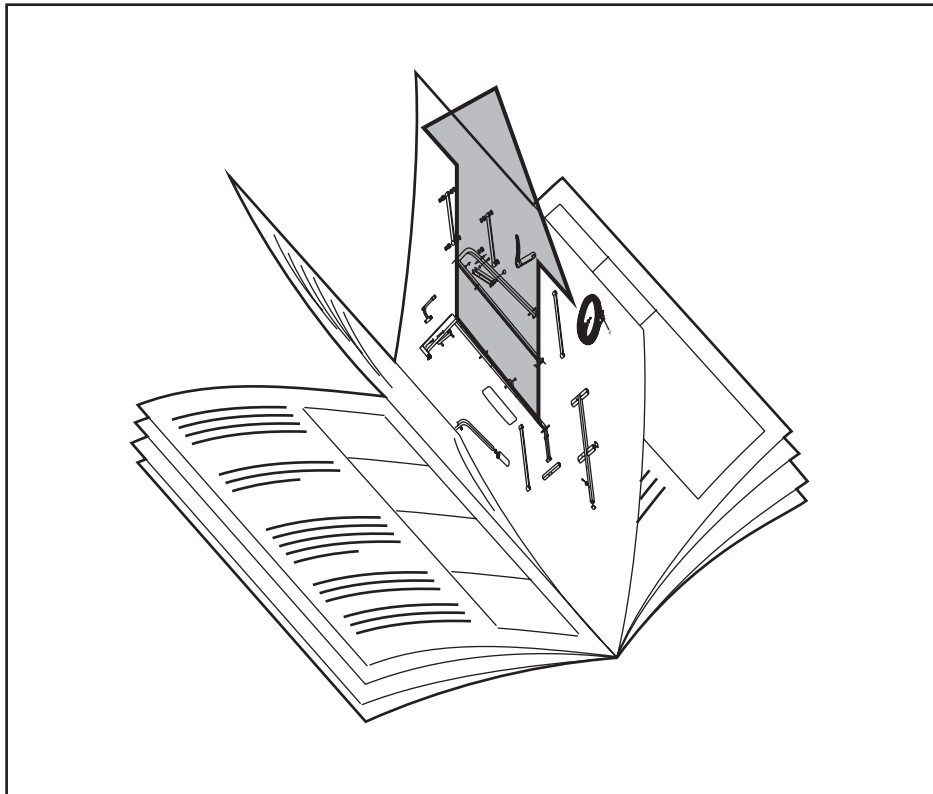

Part List—Model No. WEBE29300

R0800A

Key No.	Qty.	Description	Key No.	Qty.	Description
1	2	Upright	47	2	50mm Bushing
2	1	Rear Upright	48	2	25mm Bushing
3	1	Rear Base	49	8	45mm Square Bushing
4	1	Foot Plate	50	2	M8 x 16mm Screw
5	6	Pulley	51	2	Weight Clip
6	18	M10 Small Washer	52	1	Weight Adapter Pin
7	2	Base	53	2	M8 x 25mm Bolt
8	1	Low Cable	54	4	M8 Nylon Locknut
9	1	Top Crossbar	55	7	60mm Square Inner Cap
10	4	50mm Square Inner Cap	56	9	M10 x 65mm Bolt
11	46	M10 Nylon Locknut	57	3	Support Plate
12	8	Joint Plate	58	6	M10 Large Washer
13	1	High Cable	59	1	Pulley Bar
14	1	Cable Clip	60	2	50mm x 70mm Outer Cap
15	6	Pulley Spacer	61	6	M6 x 16mm Screw
16	1	Lat Bar	62	4	M6 x 65mm Screw
17	2	Plastic Handle	63	1	Bench Frame
18	2	Weight Guide	64	2	M10 x 60mm Carriage Bolt
19	2	Pulley Plate	65	6	Foam Pad
20	1	Base Crossbar	66	6	3/4" Round Inner Cap
21	2	Cable Trap	67	2	M8 Flat Washer
22	1	Weight Carriage	68	1	Seat
23	1	Right Safety Spotter	69	1	Backrest
24	1	Left Safety Spotter	70	1	M8 x 55mm Bolt
25	2	50mm Round Inner Cap	71	3	45mm Square Inner Cap
26	2	M10 x 20mm Bolt	72	1	Leg Lever
27	3	Carriage Bushing	73	1	Front Leg
28	1	Carriage Stop	74	1	10mm Spacer
29	4	38mm Bushing	75	1	Weight Tube
30	1	M8 x 70mm Bolt	76	1	M10 x 180mm Bolt
31	1	Right Weight Glider	77	1	Curl Pad
32	1	Left Weight Glider	78	1	Backrest Frame
33	2	Weight Adapter	79	4	25mm x 50mm Inner Cap
34	1	Locking Bar	80	1	Backrest Knob
35	1	Barbell	81	4	M6 Washer
36	1	Left Spotter Hook	82	1	Angled Outer Cap
37	1	Right Spotter Hook	83	1	Curl Post
38	2	M10 x 30mm Bolt	84	1	25mm Round Inner Cap
39	2	M10 x 75mm Bolt	85	1	M10 x 70mm Bolt
40	3	M10 x 45mm Bolt	86	1	Curl Post Knob
41	24	M10 x 80mm Bolt	87	1	Stabilizer
42	1	Weight Adapter	88	3	Pad Tube
43	4	M10 x 25mm Bolt	89	1	Backrest Bracket
44	2	Large Washer	#	1	User's Manual
45	4	Weight Clip Bushing	#	1	Exercise Guide
46	2	Weight Adapter Bushing			

Note: “#” indicates a non-illustrated part. Specifications are subject to change without notice. See the back cover of the user's manual for information about ordering replacement parts.

Exploded Drawing—Model No. WEBE29300

F0800A

