

# WEIDER PRO 545

PATENT PENDING

Model No. 831.150471  
Serial No. \_\_\_\_\_

The serial number can be found in the location shown below. Write the serial number in the space above.

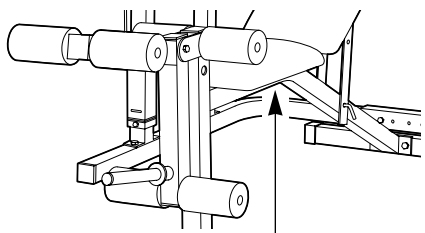

Serial Number Decal (under seat)

EXERCISE  
EQUIPMENT

QUESTIONS

HELPLINE!

1-800-736-6879

## CAUTION

Read all precautions and instructions in this manual before using this equipment. Save this manual for future reference.

## USER'S MANUAL



# SEARS

SEARS, ROEBUCK AND CO., HOFFMAN ESTATES, IL 60179

---

# TABLE OF CONTENTS

IMPORTANT PRECAUTIONS .....	.3
WARNING DECAL PLACEMENT .....	.4
BEFORE YOU BEGIN .....	.5
ASSEMBLY .....	.6
ADJUSTING THE WEIDER PRO 545 .....	.14
EXERCISE GUIDELINES .....	.17
ORDERING REPLACEMENT PARTS .....	.Back Cover
FULL 90 DAY WARRANTY .....	.Back Cover

Note: A PART IDENTIFICATION CHART and a PART LIST/EXPLODED DRAWING are attached to the center of this manual. Remove the PART IDENTIFICATION CHART and the PART LIST/EXPLODED DRAWING before beginning assembly.

---

# IMPORTANT PRECAUTIONS

**WARNING:** To reduce the risk of serious injury, read the following important precautions before using the weight bench.

1. Read all instructions in this manual before using the weight bench.
2. Use the weight bench only as described in this manual.
3. It is the responsibility of the owner to ensure that all users of the weight bench are adequately informed of all precautions.
4. Use the weight bench only on a level surface. Cover the floor beneath the weight bench for protection.
5. Inspect and tighten all parts each time you use the weight bench. Replace any worn parts immediately.
6. Keep children under 12 and pets away from the weight bench at all times.
7. Keep hands and feet away from moving parts.
8. Always wear athletic shoes for foot protection while exercising.
9. Do not use a barbell (not included) longer than six feet when the squat rack is set to the narrow width. If you are using an olympic barbell (not included) you must set the squat rack to the wide width.
10. Always be sure there is an equal amount of weight on each side of your barbell (not included) when you are using it.
11. The weight bench is designed to support a maximum of 560 pounds, including the user, a weight bar, and weights. Do not place more than 310 pounds, including a weight bar and weights, on the weight rests; do not place more than 75 pounds on each weight carriage; do not place more than 150 pounds on the leg lever for normal use.
12. When using the backrest, make sure that the "L" pin is fully inserted through the adjustment bracket and the frame on the bench.
13. Always exercise with a partner. When you are performing bench press exercises, squat exercises, or toe raise exercises, your partner should stand behind you to catch the barbell if you cannot complete a repetition.
14. The weight bench is intended for home use only. Do not use the weight bench in any commercial, rental, or institutional setting.
15. If you feel pain or dizziness at any time while exercising, stop immediately and begin cooling down.

**WARNING:** Before beginning this or any exercise program, consult your physician. This is especially important for persons over the age of 35 or persons with pre-existing health problems. Read all instructions before using. SEARS assumes no responsibility for personal injury or property damage sustained by or through the use of this product.

# WARNING DECAL PLACEMENT

The decal shown below has been placed on the weight bench and on the squat rack. If either decal is missing, or if either decal is not legible, please call our toll-free HELPLINE at 1-800-736-6879, Monday through Saturday, 7 a.m. until 7 p.m. Central Time (excluding holidays), to order a free replacement decal. Apply the replacement decal to the location shown.

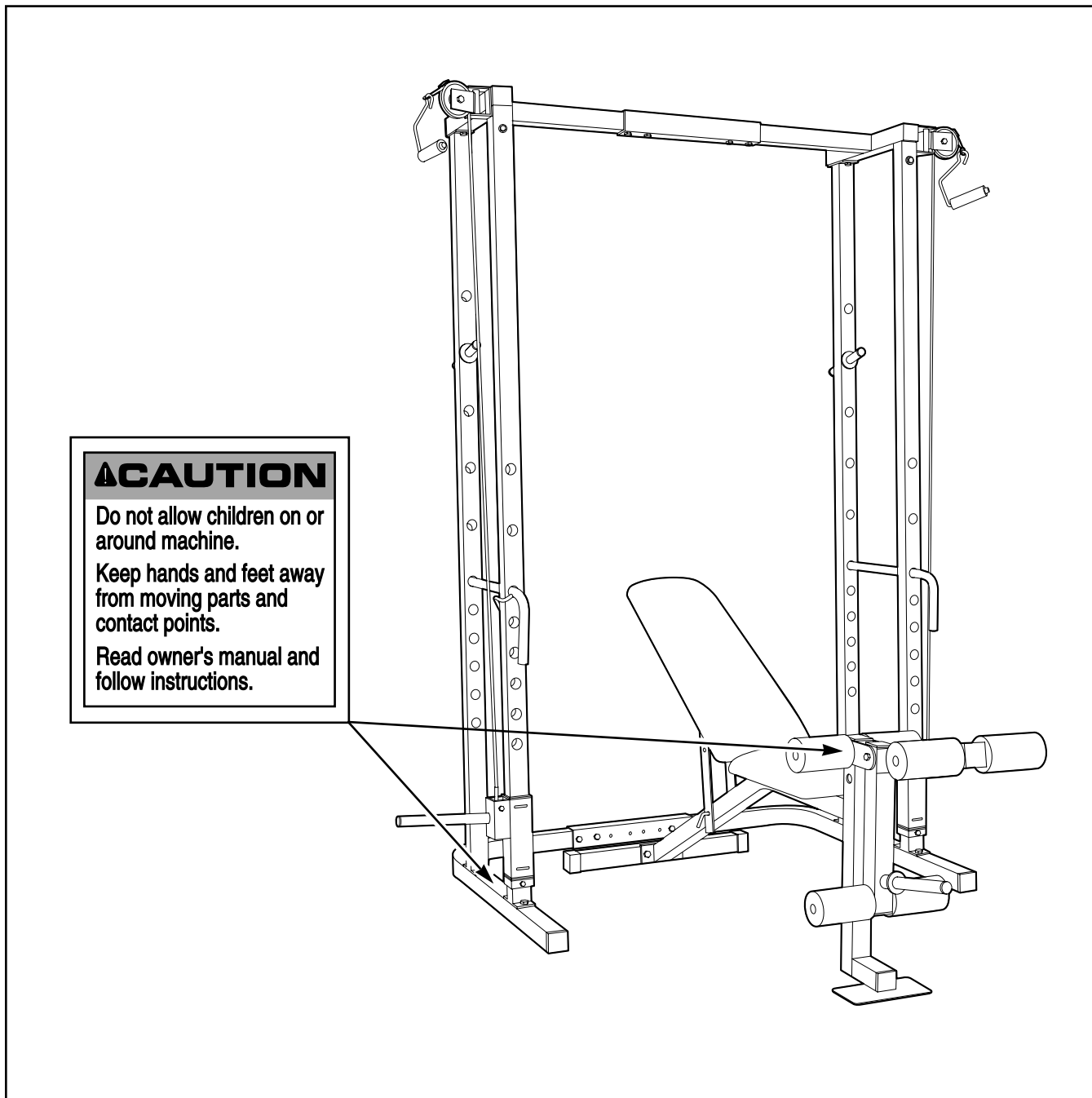

# BEFORE YOU BEGIN

Thank you for selecting the WEIDER® PRO 545 Weight Bench. The versatile PRO 545 Weight Bench is designed to be used with your own weight set (not included) to develop every major muscle group of the body. Whether your goal is a shapely figure, dramatic muscle size and strength, or a healthier cardiovascular system, the PRO 545 Weight Bench will help you to achieve the specific results you want.

**For your benefit, read this manual carefully before using the WEIDER® PRO 545 Weight Bench.** If you have additional questions, please call our toll-free

HELPLINE at 1-800-736-6879, Monday through Saturday, 7 a.m. until 7 p.m. Central Time (excluding holidays). To help us assist you, please note the product model number and serial number before calling. The model number is 831.150471. The serial number can be found on a decal attached to the PRO 545 Weight Bench (see the front cover of this manual).

Before reading further, please review the drawing below and familiarize yourself with the parts that are labeled.

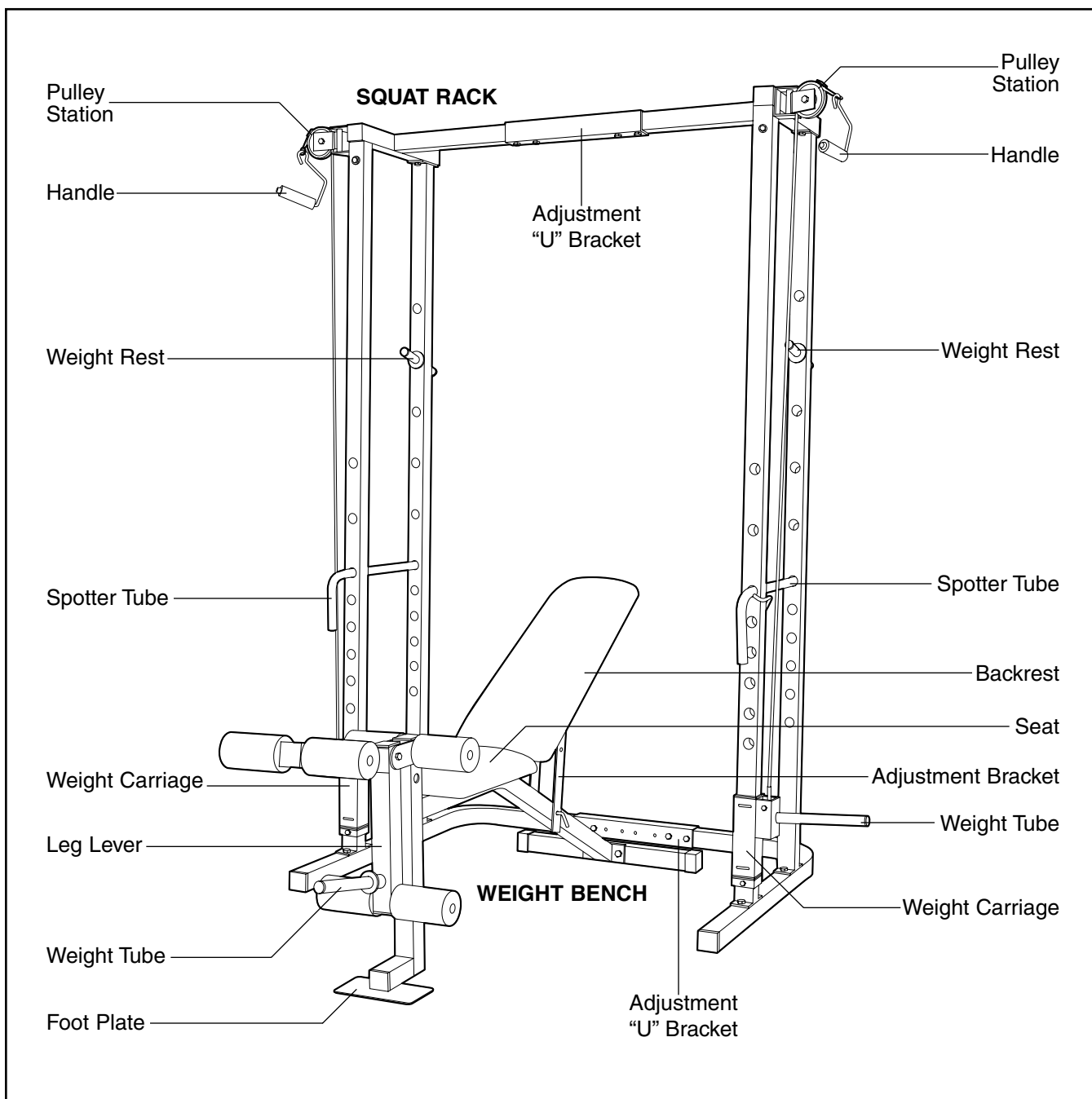



# ASSEMBLY

**Before beginning assembly, carefully read the following information and instructions:**

- Assembly requires two people.
- Place all parts in a cleared area and remove the packing materials; do not dispose of the packing materials until assembly is completed.
- Tighten all parts as you assemble them, unless instructed to do otherwise.
- For help identifying the small parts used in assembly, use the PART IDENTIFICATION CHART attached at the center of the manual.
- As you assemble the weight bench, be sure that all parts are oriented as shown in the drawings.

**THE FOLLOWING TOOLS (NOT INCLUDED) ARE REQUIRED FOR ASSEMBLY:**

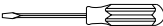
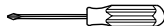
- **Two (2) adjustable wrenches** 
- **One (1) rubber mallet** 
- **One (1) standard screwdriver** 
- **One (1) phillips screwdriver** 
- **Lubricant, such as grease or petroleum jelly, and soapy water will also be needed.**

Assembly will be more convenient if you have the following tools: A socket set, a set of open-end or closed-end wrenches, or a set of ratchet wrenches.

1. **Before assembling this product, be sure that you have read and understand the information in the box above.**

Press a 50mm Square Outer Cap (40) onto each side of the Stabilizer (33).

Attach the Stabilizer (33) to the Bench Frame (49) with two M8 x 68mm Bolts (8), two M8 Washers (13) and two M8 Nylon Locknuts (12).

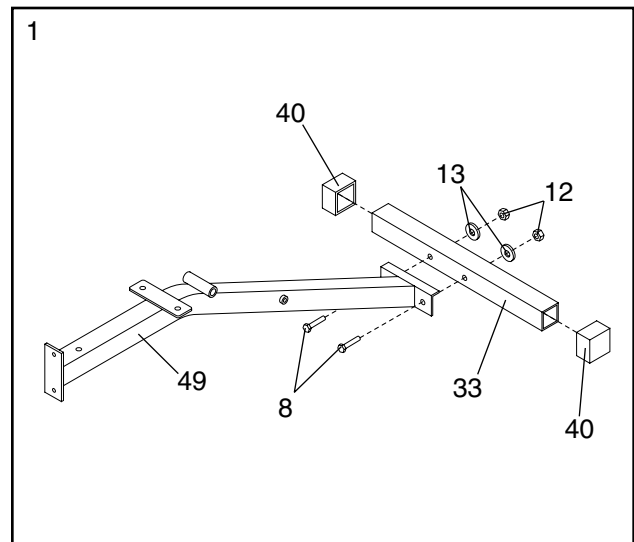

2. Press a 50mm Square Inner Cap (36) into each end of the Front Leg (22).

Attach the Front Leg (22) to the Bench Frame (49) with two M8 x 68mm Bolts (8), two M8 Washers (13) and two M8 Nylon Locknuts (12).

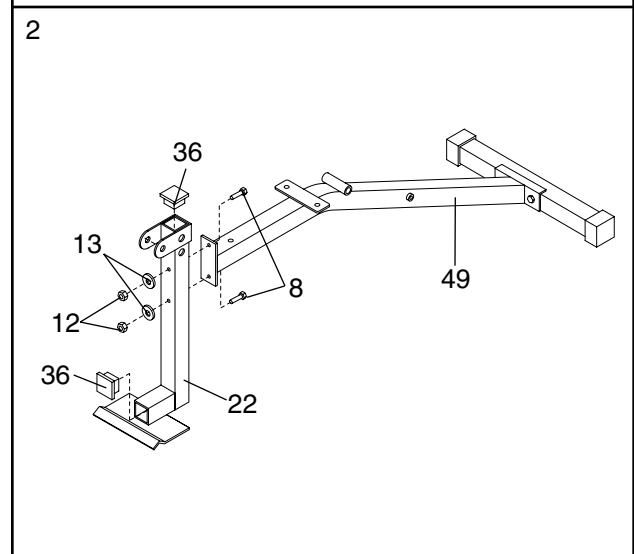

3. Press 20mm x 40mm Inner Caps (44) into the ends of both Backrest Tubes (25).

Lubricate an M10 x 152mm Bolt (11). Attach the Backrest Tubes (25) to the Bench Frame (49) with the Bolt and an M10 Nylon Locknut (14). **See the inset drawing. The indicated hole in the Backrest Tube (25) is slightly off center. The Backrest Tube must be oriented as shown, when it is attached to the Bench Frame (49). Do not overtighten the Nylon Locknut; the Backrest Brackets must be able to move freely.**

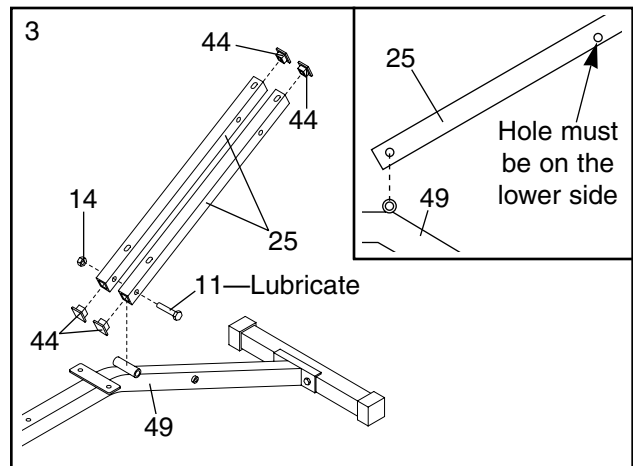

4. Slide the Adjustment Bracket (26) onto the Bench Frame (49). See the inset drawing. The guide rod inside the Adjustment Bracket must be on the indicated side of the welded tube in the Bench Frame.

Align one set of holes in the Adjustment Bracket (26) with the hole in the Bench Frame (49). Insert the "L" Pin (46) through the Adjustment Bracket and the Bench Frame.

Lubricate an M10 x 152mm Bolt (11). Attach the Adjustment Bracket (26) to the Backrest Tubes (25) with the Bolt, two Adjustment Bracket Spacers (50), and an M10 Nylon Locknut (14). **Do not overtighten the Nylon Locknut; the Backrest Brackets and Adjustment Bracket must be able to move freely.**

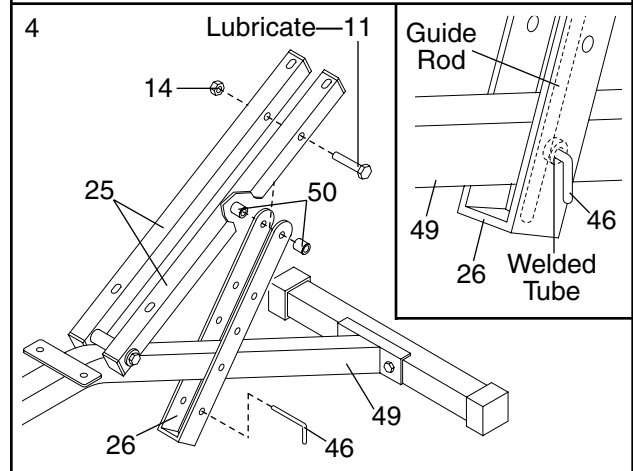

5. Attach the Backrest (29) to the Backrest Tubes (25) with four M6 x 48mm Screws (35) and four M6 Washers (42). Note: Before you attach the Backrest to the Backrest Tubes, look at the back side of the Backrest. You will notice that one set of threaded holes is closer to the end of the Backrest (see the inset drawing). This end of the Backrest must be closest to the Bench Frame (49).

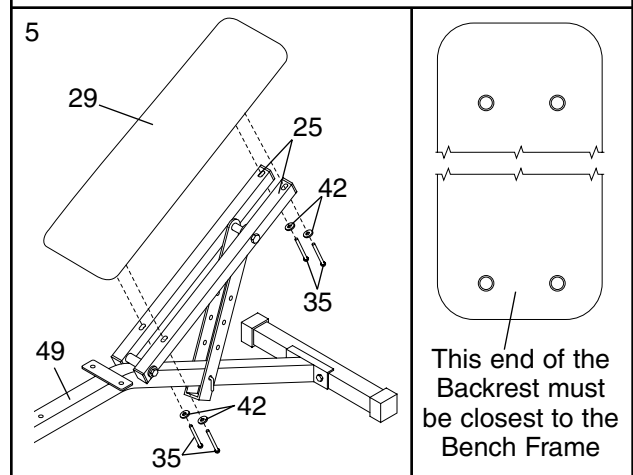

6. Attach the Seat (34) to the Bench Frame (49) with the M6 x 60mm Screw (16), two M6 x 16mm Screws (17), and three M6 Washers (42).

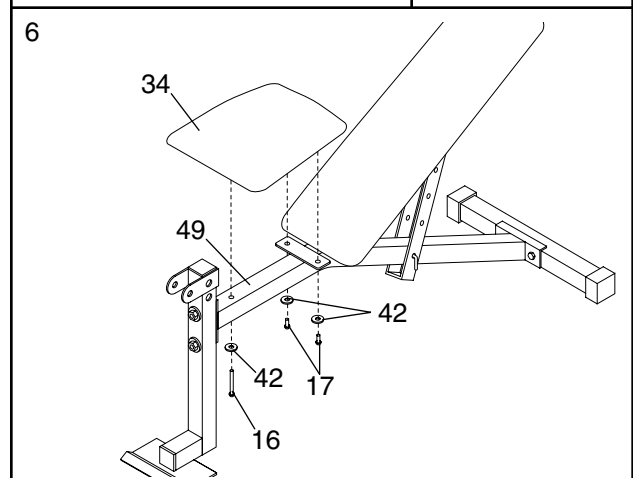

- Press three 50mm Square Inner Caps (36) into the Leg Lever (32). Press a 1" Round Inner Cap (41) into the Leg Lever. Press a 1" Angle Cap (5) onto the Leg Lever.

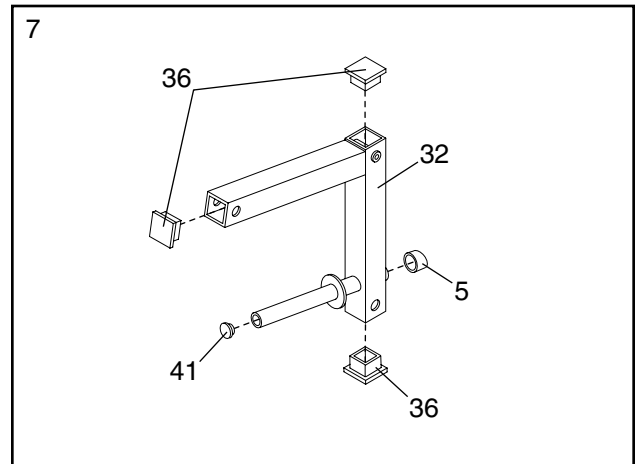

- Lubricate the M10 x 75mm Bolt (10). Attach the Leg Lever (32) to the Front Leg (22) with the Bolt and an M10 Nylon Locknut (14).

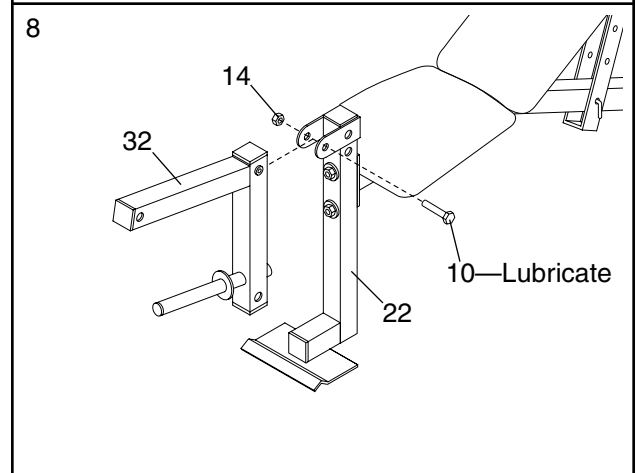

- Tap 3/4" Round Inner Caps (43) into each end of the three Pad Tubes (38).

Insert a Pad Tube (38) through one hole in the Leg Lever (32). Insert another Pad Tube through the other hole in the Leg Lever. Insert the remaining Pad Tube through the upper hole in the Front Leg (22).

Slide two Foam Pads (48) onto each Pad Tube (38).

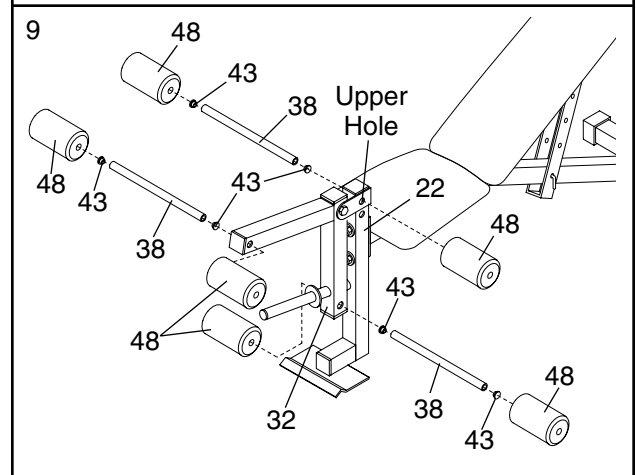

- Set each section of the Base (20, 55) on the floor. Be sure that the indented side of each section of the Base is facing the floor. Press a 50mm Square Inner Cap (36) into the indicated end of each section of the Base.

Insert four M8 x 58mm Carriage Bolts (6) into each section of the Base (20, 55).

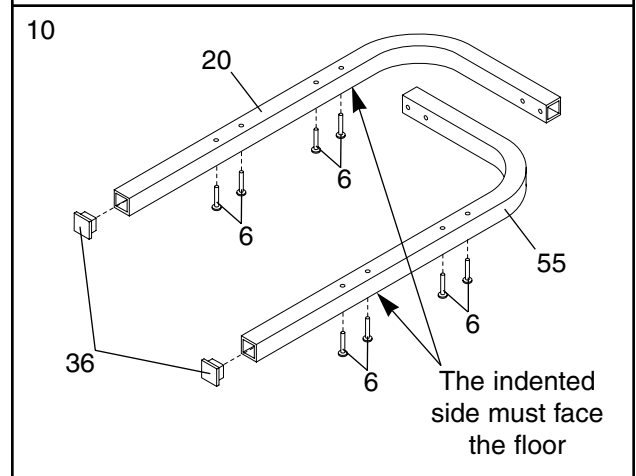



11. Note: The WEIDER PRO 545 is designed to be used with both olympic and standard barbells. If you will be using an olympic barbell, assemble the base in the wide position, as shown in the main drawing. If you will be using a standard barbell, assemble the base in the narrow position, as shown in the inset drawing.

Attach each section of the Base (20, 55) to an Adjustment "U" Bracket (31) with two M8 x 68mm Bolts (8) and two M8 Nylon Locknuts (12). **Do not tighten the Nylon Locknuts yet.**

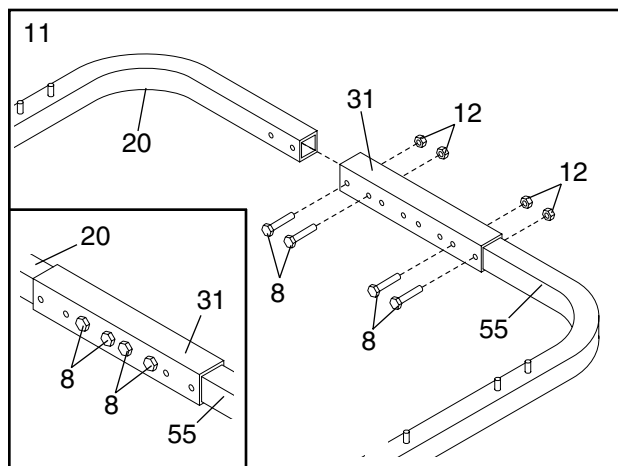

12. Slide a Rear Upright (19) onto the indicated M8 x 58mm Carriage Bolts (6) in either section of the Base (20, 55). **The Rear Upright must be oriented as shown, with the indicated holes facing forward. A second person must hold the Upright at the location shown during the step.** Partially tighten an M8 Nylon Locknut (12) onto each Carriage Bolt **but do not fully tighten the Nylon Locknut. Note: The heads of the Carriage Bolts must lock into the square holes in each section of the Base in order to tighten the Nylon Locknuts; you may need to slide your fingers under the Base to hold the Carriage Bolts in place while you partially tighten the Nylon Locknuts.**

Assemble the other Rear Upright (19) in the same manner.

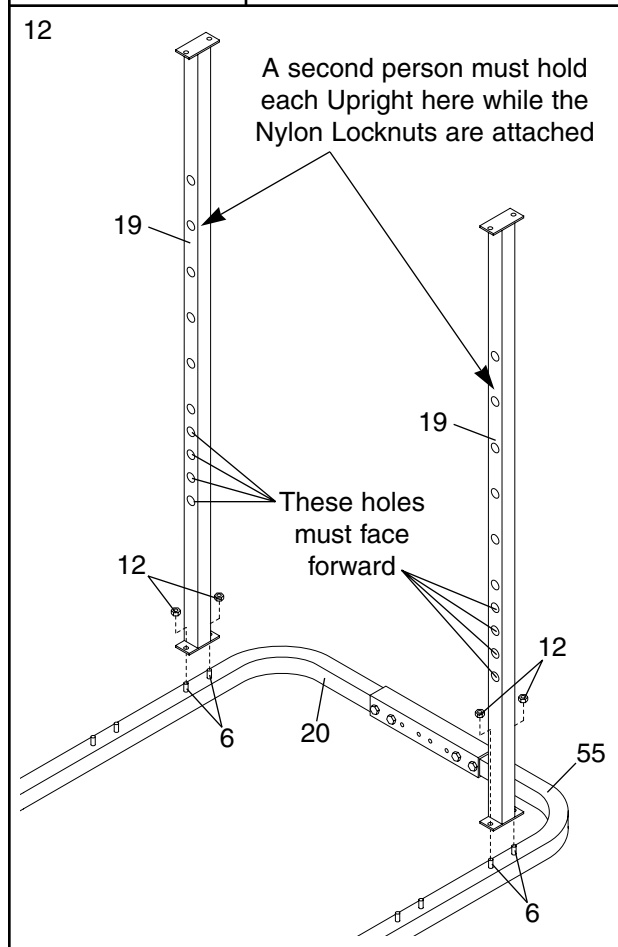

13. Press 1" Round Inner Caps (41) into the ends of the Weight Rests (37).

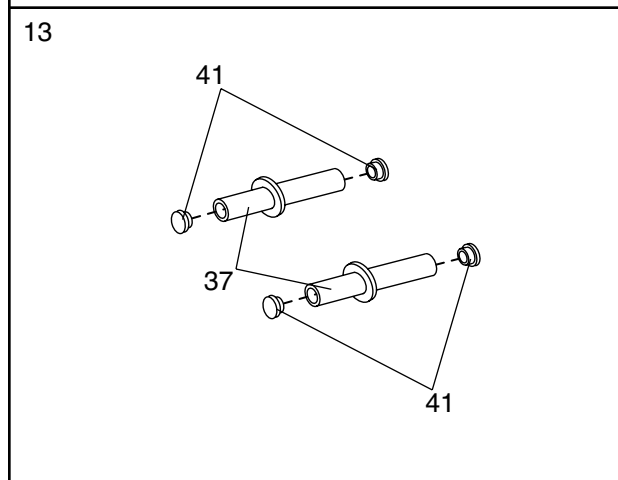

14. Insert a Weight Rest (37) into each Rear Upright (19). **Be sure that the Weight Rests are inserted at the same level on both sides.**

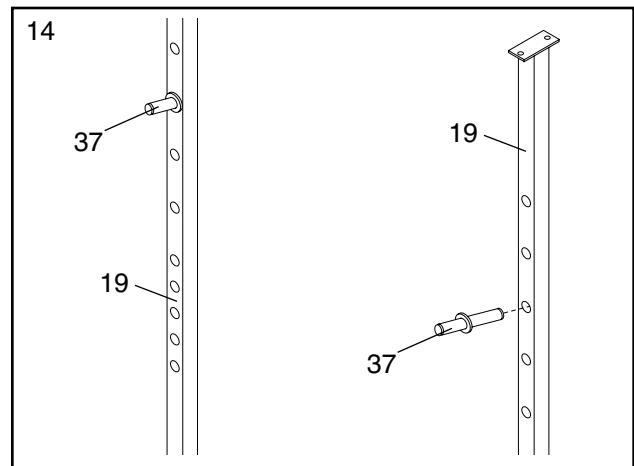

15. Slide a Front Upright (18) onto the indicated M8 x 58mm Carriage Bolts (6) in either section of the Base (20, 55). **A second person must hold the Upright at the location shown during the step.** Partially tighten an M8 Nylon Locknut (12) onto each Carriage Bolt **but do not fully tighten the Nylon Locknut.** **Note: The heads of the Carriage Bolts must lock into the square holes in each section of the Base in order to tighten the Nylon Locknuts; you may need to slide your fingers under the Base to hold the Carriage Bolts in place while you partially tighten the Nylon Locknuts.**

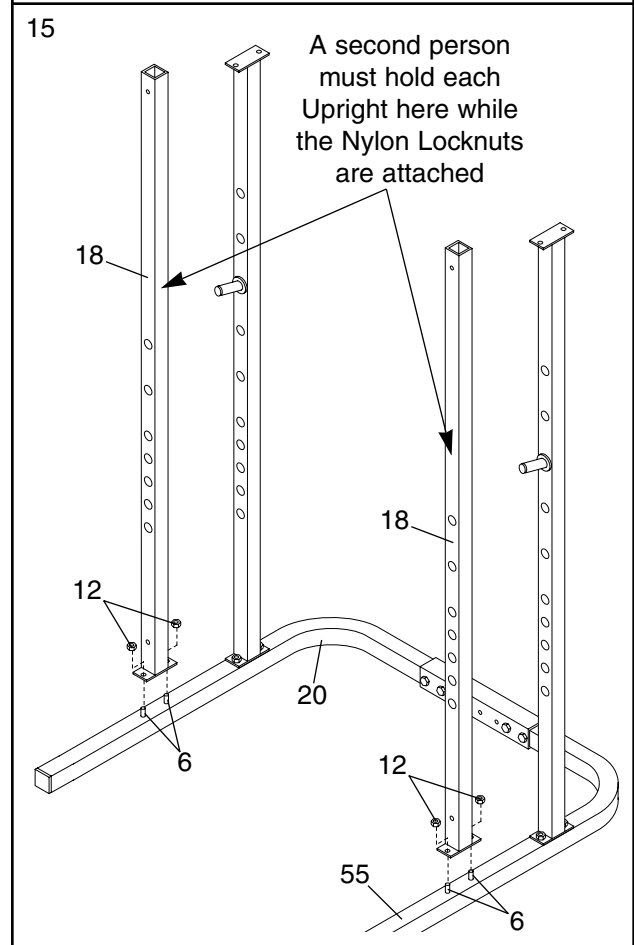

Assemble the other Front Upright (18) in the same manner.

16. Press two 60mm Square Bushings (53) into a Weight Carriage (52). Press a 1" Round Inner Cap (41) into the Weight Carriage.

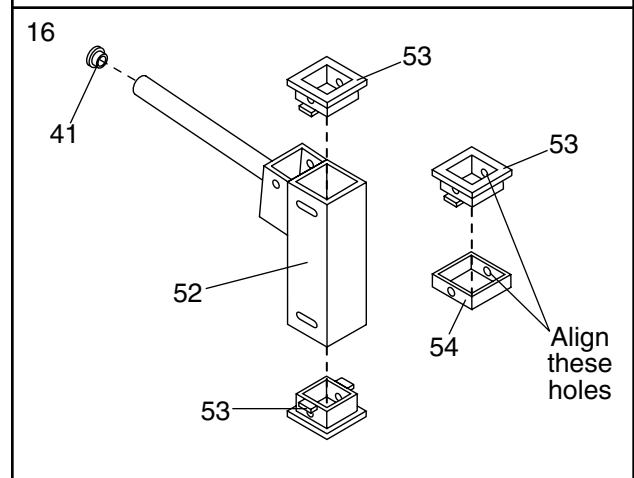

Assemble the other Weight Carriage (52) in the same manner.

Press a 60mm Square Bushing (53) into the Carriage Stop (54). **The drilled hole in the Square Bushing must be aligned with the drilled hole in the Carriage Stop.**

17. Slide a Carriage Stop (54) onto a Front Upright (18). **Be sure that the 60mm Square Bushing (53) is facing up. Align the holes in the Carriage Stop with the holes in the Front Upright.** Insert an M8 x 68mm Bolt (8) through the Carriage Stop and Front Upright. Tighten an M8 Nylon Locknut (12) onto the Bolt.

Slide a Weight Carriage (52) onto the Front Upright (18). **The weight tube must be on the side shown.**

Attach the other Carriage Stop (54) and Weight Carriage (52) in the same manner.

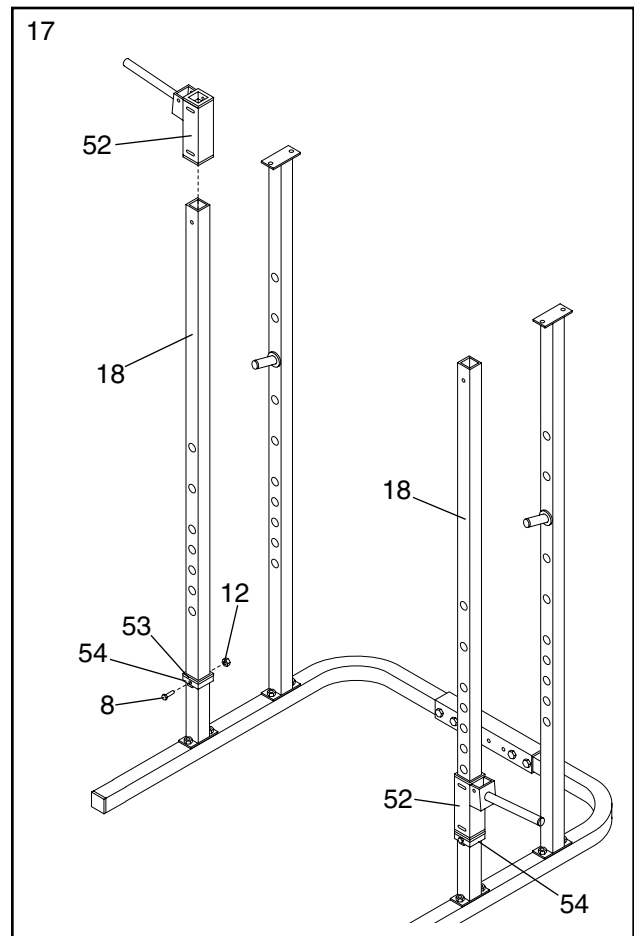

18. Press two 50mm Square Inner Caps (36) into each section of the Top Frame (21, 39).

Note: As in step 11, if you will be using an olympic barbell, assemble the top frame in the wide position, as shown in the main drawing. If you will be using a standard barbell, assemble the top frame in the narrow position, as shown in the inset drawing.

Attach each section of the Top Frame (21, 39) to the other Adjustment "U" Bracket (31) with two M8 x 68mm Bolts (8) and two M8 Nylon Locknuts (12). **Do not tighten the Nylon Locknuts yet.**

If you are assembling each section of the Top Frame (21, 39) in the wide position, attach the Spacer Tube (1) inside the Adjustment "U" Bracket (31) with two M8 x 68mm Bolts (8) and two M8 Nylon Locknuts (12). **Do not tighten the Nylon Locknuts yet.**

**Note: If you are assembling each section of the Top Frame (21, 39) in the narrow position, store the Spacer Tube (1), the two extra M8 x 68mm Bolts (8), and the two extra M8 Nylon Locknuts (12) in a safe place. If you ever purchase an olympic barbell, you will need these parts (see ADJUSTING THE WIDTH OF THE SQUAT RACK on page 16).**

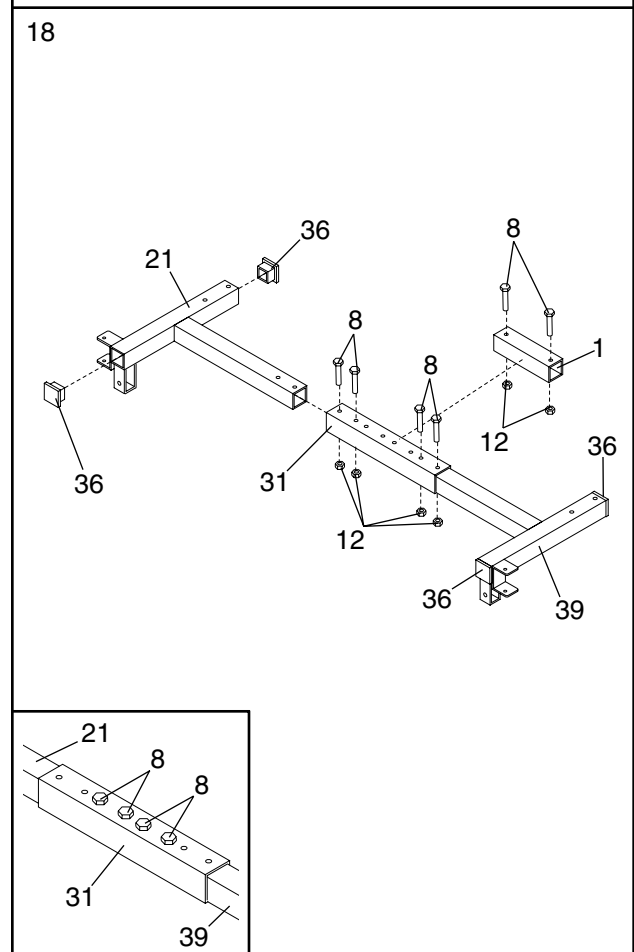

19. Attach each section of the Top Frame (21, 39) to the Front Uprights (18) with an M8 x 68mm Bolt (8), two M8 Washers (13), and an M8 Nylon Locknut (12).

Attach each section of the Top Frame (21, 39) to the Rear Uprights (19) with two M8 x 68mm Bolts (8), two M8 Washers (13), and two M8 Nylon Locknuts (12).

**Tighten all Nylon Locknuts and Bolts used in steps 11–19.**

20. Attach a Cable (51) to one of the Weight Carriages (52) with an M10 x 75mm Bolt (10), two Cable Spacers (45), and an M10 Nylon Locknut (14).

Attach the other Cable to the other Weight Carriage (not shown) in the same manner.

21. Lubricate an M10 x 90mm Bolt (7). Attach a “U” Bracket (30) to Top Frame B (39) with the Bolt and an M10 Nylon Locknut (14). **Do not overtighten the Nylon Locknut.**

Attach the other “U” Bracket to Top Frame A (not shown) in the same manner

22. Wrap the indicated Cable (51) around a Pulley (24). Attach the Pulley to the “U” Bracket (30) with an M10 x 48mm Bolt (9), a Cable Trap (23), and an M10 Nylon Locknut (14). **The Cable must be routed around the Pulley from the direction shown. The Cable Trap should be attached on the outside of the “U” Bracket and should be turned to hold the Cable in place.**

Assemble the other Pulley to the other “U” Bracket (not shown) in the same manner.

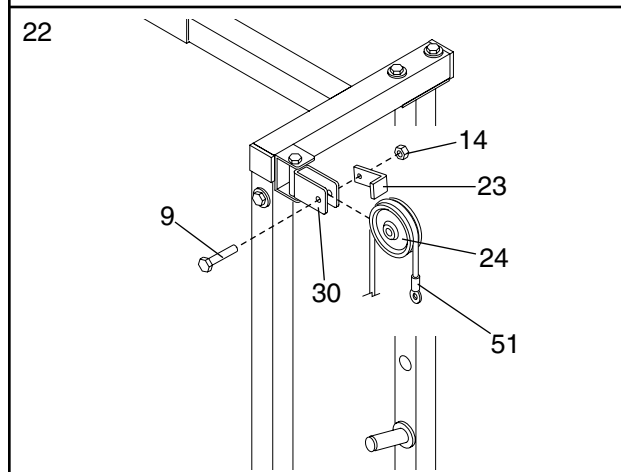
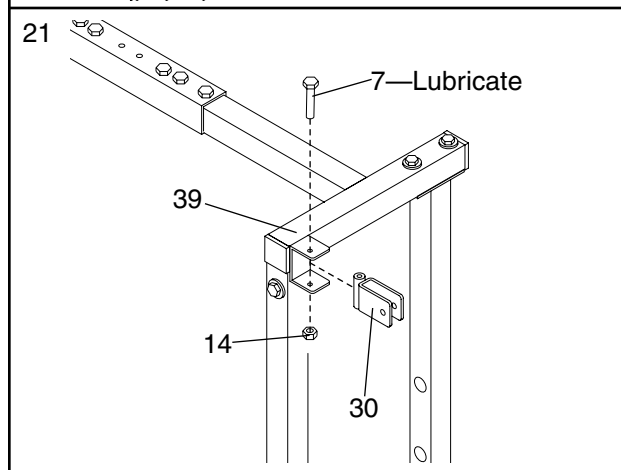
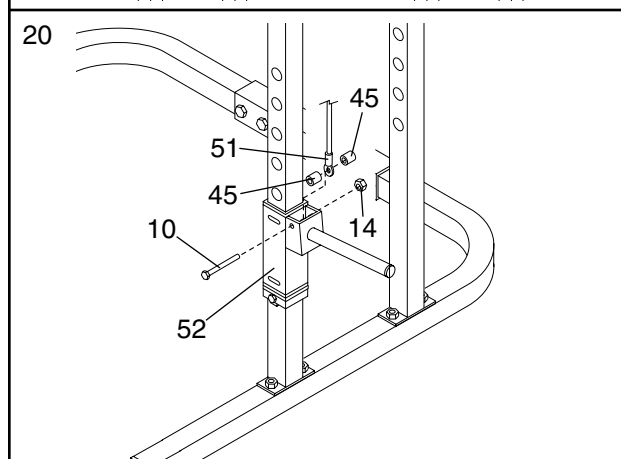
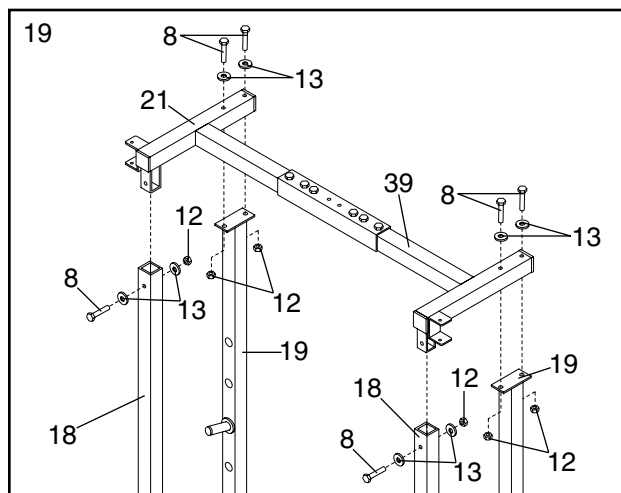

23. Press a 1" Round Inner Cap (41) into each end of a Spotter Tube (4).

Press a 1" Round Inner Cap into each end of the other Spotter Tube (not shown).

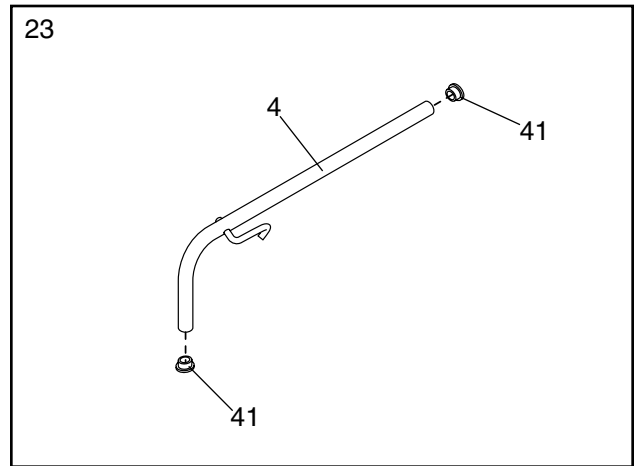

24. Insert a Spotter Tube (4) through a Front Upright (18) and into a Rear Upright (19). Rotate the Spotter Tube so that the hook locks in place around the Front Upright.

Insert the other Spotter Tube through the other Front and Rear Upright (not shown) in the same manner. **Be sure that the Spotter Tubes are inserted at the same level on both sides.**

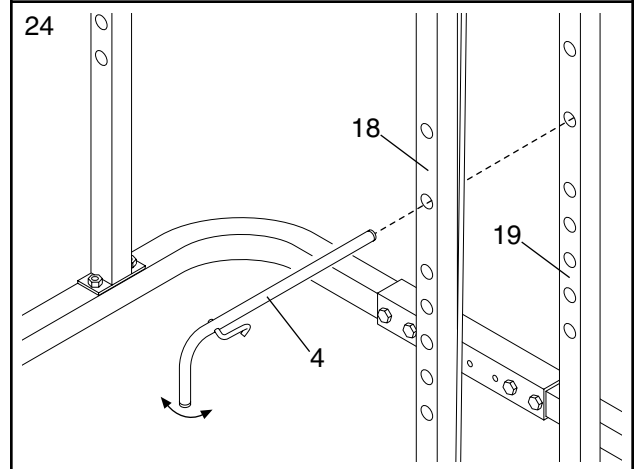

25. Attach the indicated Handle (27) to one of the Cables (51) by inserting the hook on the end of the Handle through the loop in the end of the Cable.

Attach the other Handle to the other Cable (not shown) in the same manner.

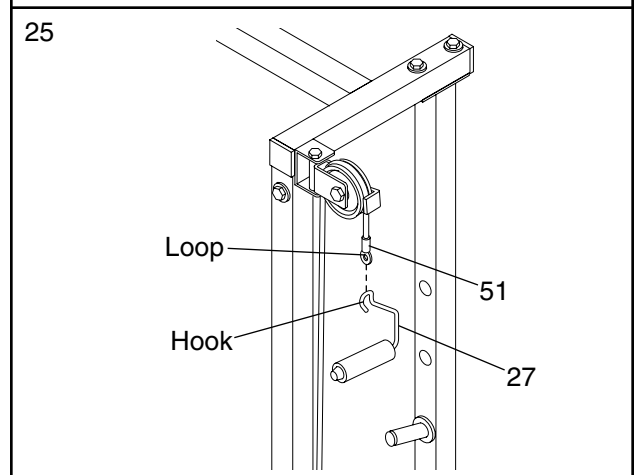

26. Make sure that all parts are properly tightened before you use the weight bench.

# ADJUSTING THE WEIDER PRO 545

The weight bench is designed to be used with your own weight set (not included). The steps below explain how the weight bench can be adjusted. See EXERCISE GUIDELINES on page 17 for important exercise information and refer to the accompanying exercise poster to see the correct form for each exercise. Refer also to the exercise information accompanying your weight set (not included) for additional exercises.

Inspect and tighten all parts each time you use the weight bench. Replace any worn parts immediately. The weight bench can be cleaned with a damp cloth and a mild, non-abrasive detergent. Do not use solvents.

## ADJUSTING THE BACKREST

The Backrest (29) can be set at four different positions: the level position, the decline position, and two incline positions.

To change the position of the Backrest (29), remove the "L" Pin (46) from the Adjustment Bracket (26) and the Bench Frame (49). Set the Backrest to the desired position, align the holes in the Adjustment Bracket and the Bench Frame, and re-insert the "L" Pin.

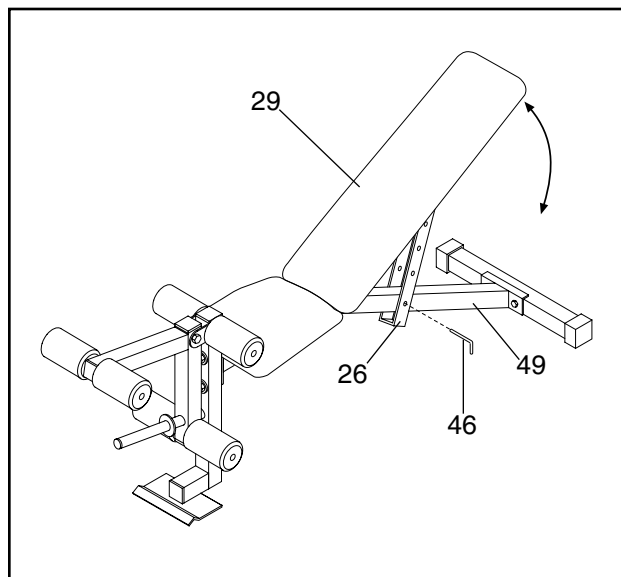

## ATTACHING WEIGHTS TO THE WEIGHT CARRIAGE

To use the pulley station, slide the desired amount of weight (not included) onto the weight tube on each Weight Carriage (52). Be sure there is an equal amount of weight on each Weight Carriage. Secure the weights on each Weight Carriage with a Spring Clip (47).

**WARNING: Do not place more than 75 pounds on each weight carriage.**

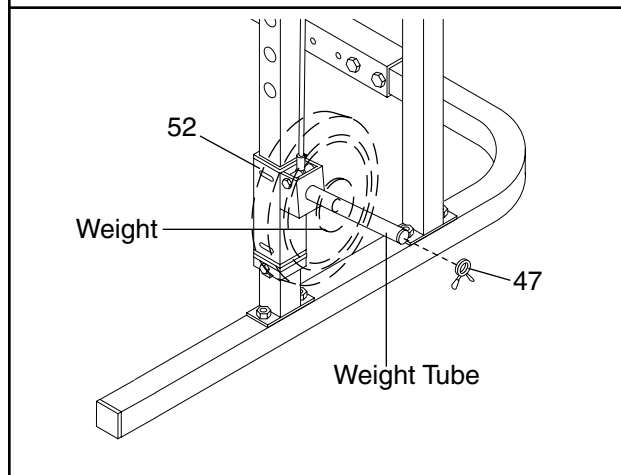

## ATTACHING WEIGHTS TO THE LEG LEVER

To use the Leg Lever (32), slide the desired amount of weight (not included) onto the weight tube. Secure the weight with a Spring Clip (47).

**WARNING: Do not place more than 150 pounds on the leg lever.**

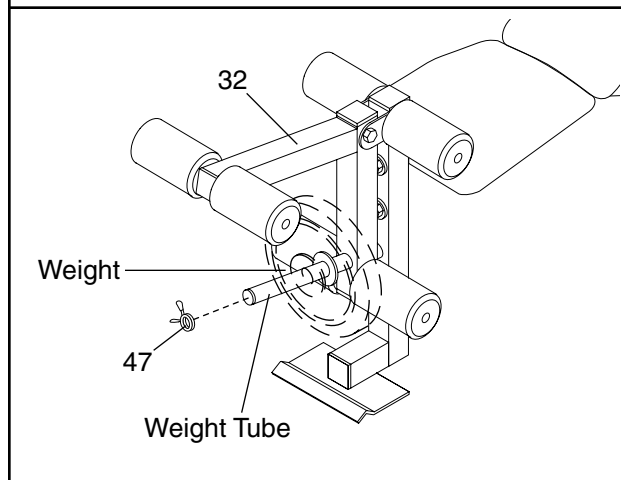

## ADJUSTING THE WEIGHT RESTS

Squat exercises and toe raise exercises naturally require that the Weight Rests (37) be set to a different height than bench press exercises. You should always set the Weight Rests to a height which is comfortable for the exercise you will perform.

To adjust the Weight Rests (37), insert the Weight Rests into the adjustment holes in the Rear Uprights (19) at the desired height. **Be sure that each Weight Rest is firmly seated in the adjustment hole and that both Weight Rests are at the same height.**

**WARNING: Do not place more than 310 pounds, including a weight bar and weights, on the weight rests.**

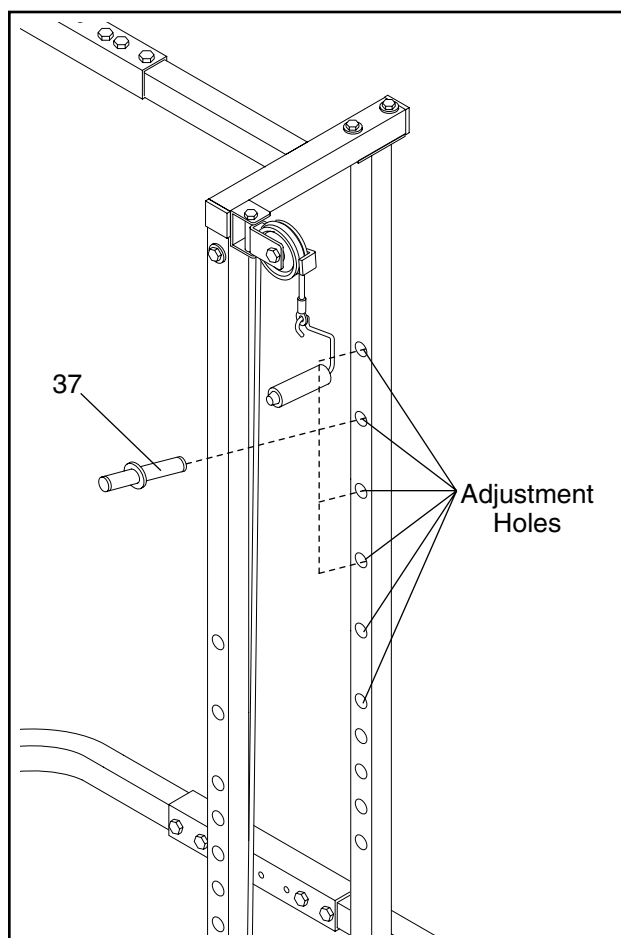

## ADJUSTING THE SPOTTER TUBES

To perform bench press exercises, squat exercises or toe raise exercises (see the accompanying EXERCISE POSTER) you will need to set the Spotter Tubes (4) at a level which is just below the lowest point that the barbell (not included) will travel during the exercise. The Spotter Tubes can help reduce the risk of injury if you cannot complete a repetition while exercising.

**WARNING: Always exercise with a partner. When you are performing bench press exercises, squat exercises or toe raise exercises, your partner should stand behind you to catch the barbell if you cannot complete a repetition.**

To adjust the Spotter Tubes (4), insert the Spotter Tubes through the adjustment holes in the Front Uprights (18) and into the adjustment holes in the Rear Uprights (19) at the desired height. **Rotate each Spotter Tube so that the hook locks in place around each Front Upright. Be sure that the Spotter Tubes are inserted at the same level on both sides.**

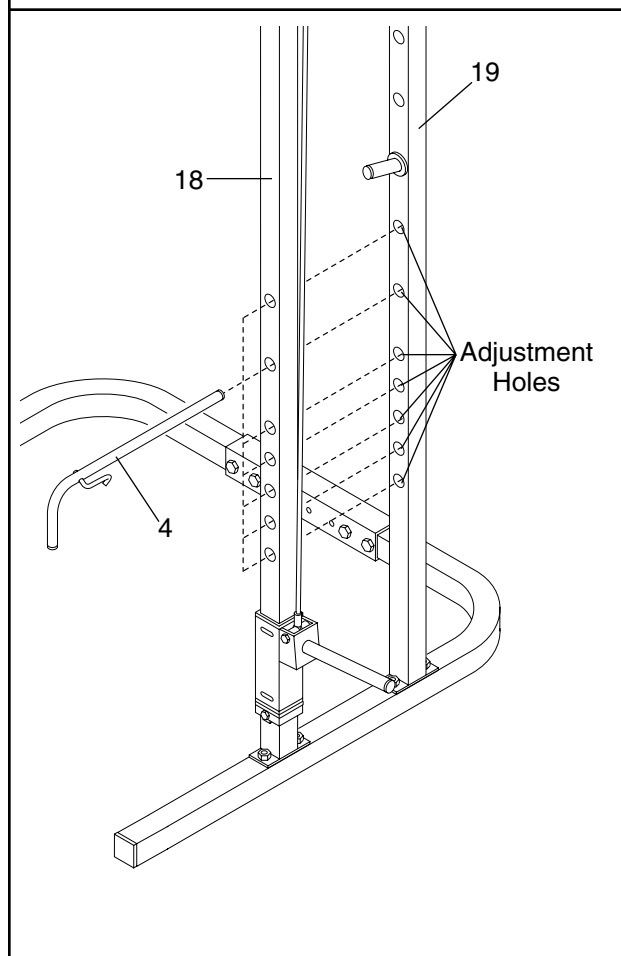

## ADJUSTING THE POSITION OF THE PAD TUBE

For some exercises you may want to move the Pad Tube (38) to the lower hole in the Front Leg (22). For other exercises you will want to leave the Pad Tube in the upper hole. For different exercises you should select the position which is most comfortable for you.

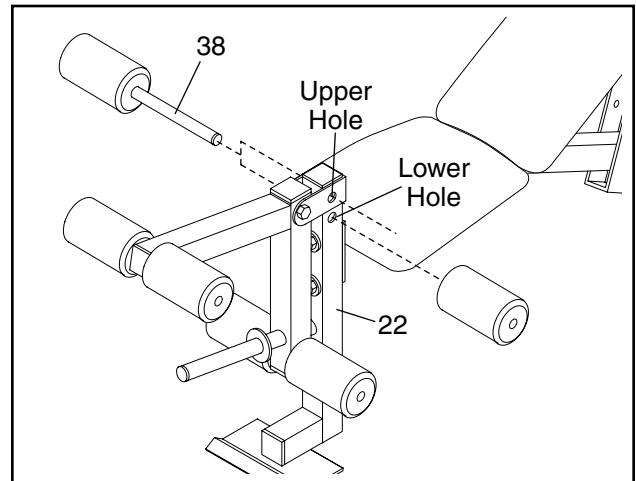

## ADJUSTING THE WIDTH OF THE SQUAT RACK

If you buy a new barbell, you may need to change the width of the squat rack. **If you are using an olympic barbell, you must use the wide setting. If you are using a five or six foot long barbell, you must use the narrow setting.**

**To move the squat rack from the narrow setting to the wide setting:** Remove the Adjustment “U” Bracket (31), four M8 x 68mm Bolts (8), and four M8 Nylon Locknuts (12) from each section of the Base (20, 55). Remove the Adjustment “U” Bracket (31), four M8 x 68mm Bolts (8), and four M8 Nylon Locknuts (12) from each section of the Top Frame (21, 39). Re-assemble the Base and Top Frame in the wide position, as shown in the main drawing. Attach the Spacer Tube (1) inside the upper Adjustment “U” Bracket (31) with two M8 x 68mm Bolts (8) and two M8 Nylon Locknuts (12).

**To move the squat rack from the wide setting to the narrow setting:** Remove the Adjustment “U” Bracket (31), four M8 x 68mm Bolts (8), and four M8 Nylon Locknuts (12) from each section of the Base (20, 55). Remove the Adjustment “U” Bracket (31), six M8 x 68mm Bolts (8), six M8 Nylon Locknuts (12), and the Spacer Tube (1) from each section of the Top Frame (21, 39). Re-assemble the Base in the narrow position, as shown in drawing A. Re-assemble the Top Frame in the narrow position, as shown in drawing B. **Save the Spacer Tube (1), the two extra M8 x 68mm Bolts (8), and the two extra M8 Nylon Locknuts (12) for future use.**

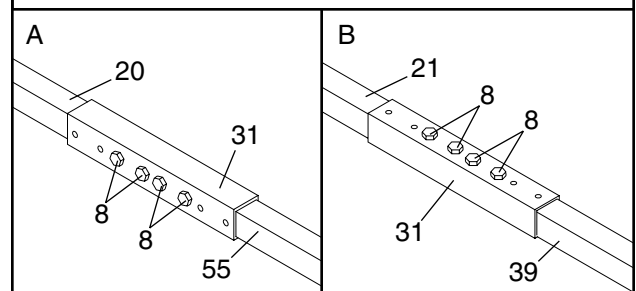
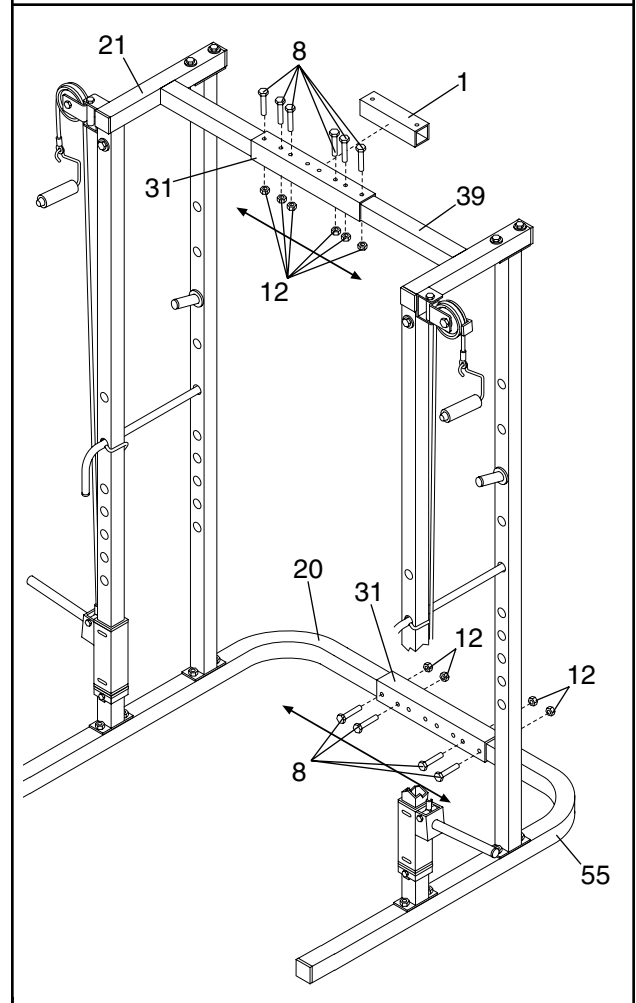

**WARNING: Do not use a barbell longer than six feet when the squat rack is set to the narrow width. If you are using an olympic barbell you must set the squat rack to the wide width.**



---

# EXERCISE GUIDELINES

## THE FOUR BASIC TYPES OF WORKOUTS

### • Muscle Building

In order to increase the size and strength of your muscles, you must push your muscles to a high percentage of their capacity. You must also progressively increase the intensity of your exercise so that your muscles will continually adapt and grow. Each individual exercise can be tailored to the proper intensity level by changing the amount of weight used, or the number of repetitions or sets performed. (A “repetition” is one complete cycle of an exercise, such as one sit-up. A “set” is a series of repetitions performed consecutively.)

The proper amount of weight for each exercise depends upon the individual user. It is up to you to gauge your limits. Select the amount of weight that you think is right for you. Begin with 3 sets of 8 repetitions for each exercise that you perform. Rest for 3 minutes after each set. When you can complete 3 sets of 12 repetitions without difficulty, increase the amount of weight.

### • Toning

To tone your muscles, you must push your muscles to a moderate percentage of their capacity. Select a moderate amount of weight and increase the number of repetitions in each set. Complete as many sets of 15 to 20 repetitions as possible without discomfort. Rest for 1 minute after each set. Work your muscles by completing more sets rather than by using high amounts of weight.

### • Weight Loss

To lose weight, use a low amount of weight and increase the number of repetitions in each set. Exercise for 20 to 30 minutes, resting for a maximum of 30 seconds between sets.

### • Cross Training

In the pursuit of a complete and well-balanced fitness program, many have found that cross training is the answer. We recommend that on Monday, Wednesday and Friday, you plan weight training workouts. On Tuesday and Thursday, plan 20 to 30 minutes of aerobic exercise, such as cycling, running or swimming. Rest from both weight training and aerobic exercise for at least one full day each week to give your body time to regenerate. By combining weight training with aerobic exercise, you can reshape and strengthen your body, plus develop a stronger heart and lungs.

## PERSONALIZING YOUR EXERCISE PROGRAM

We have not specified an exact length of time for each workout, or a specific number of repetitions or sets for each exercise. It is very important to avoid overdoing it during the first few months of your exercise program, and to progress at your own pace. If you experience pain or dizziness at any time while exercising, stop immediately and begin to cool down. Find out what is wrong before continuing. Remember that adequate rest and a proper diet are also important.

### WARMING UP

Begin each workout with 5 to 10 minutes of light stretching and exercise to warm up. Warming up prepares your body for exercise by increasing circulation, raising your body temperature and delivering more oxygen to your muscles.

### WORKING OUT

Each workout should include 6 to 10 different exercises. Select exercises for every major muscle group, with emphasis on the areas that you want to develop the most. To give balance and variety to your workouts, vary the exercises from workout to workout.

Schedule your workouts for the time of day when your energy level is the highest. Each workout should be followed by at least one day of rest. Once you find the schedule that is right for you, stick with it.

### EXERCISE FORM

In order to obtain the greatest benefits from exercising, it is essential to maintain proper form.

Maintaining proper form means moving through the full range of motion for each exercise, and moving only the appropriate parts of the body. Exercising in an uncontrolled manner will leave you feeling exhausted. On the exercise poster accompanying this manual, you will find photographs showing the correct form for several exercises. A description of each exercise is also provided, along with a list of the muscles affected. Refer to the muscle chart on page 18 to find the locations of the muscles.

The repetitions in each set should be performed smoothly and without pausing. The exertion stage of each repetition should last about half as long as the return stage. Proper breathing is important. Exhale during the exertion stage of each repetition and inhale during the return stroke; never hold your breath. Rest

for 3 minutes after each set if you are doing a muscle building workout, 1 minute after each set if you are doing a toning workout, and 30 seconds after each set if you are doing a weight loss workout. Plan to spend the first couple of weeks familiarizing yourself with the equipment and learning the proper form for each exercise.

### COOLING DOWN

End each workout with 5 to 10 minutes of stretching. Include stretches for both your arms and legs. Move slowly as you stretch—do not bounce. Ease into each stretch gradually and go only as far as you can without strain. Stretching at the end of each workout is very effective for increasing flexibility.

### STAYING MOTIVATED

For motivation, keep a record of each workout. The chart on page 19 of this manual can be photocopied and used to schedule and record your workouts. List the date, exercises performed, weight, and numbers of sets and repetitions completed. Record your weight and key body measurements at the end of every month.

Remember, the key to achieving the greatest results is to make exercise a regular and enjoyable part of your everyday life.

### MUSCLE CHART

- A. Sternomastoid (neck)
- B. Pectoralis Major (chest)
- C. Biceps (front of arm)
- D. Obliques (waist)
- E. Brachioradials (forearm)
- F. Hip Flexors (upper thigh)
- G. Abductor (outer thigh)
- H. Quadriceps (front of thigh)
- I. Sartorius (front of thigh)
- J. Tibialis Anterior (front of calf)
- K. Soleus (front of calf)
- L. Rectus Abdominus (stomach)
- M. Adductor (inner thigh)
- N. Trapezius (upper back)
- O. Rhomboideus (upper back)
- P. Deltoid (shoulder)
- Q. Triceps (back of arm)
- R. Latissimus Dorsi (mid back)
- S. Spinae Erectors (lower back)
- T. Gluteus Medius (hip)
- U. Gluteus Maximus (buttocks)
- V. Hamstring (back of leg)
- W. Gastrocnemius (back of calf)

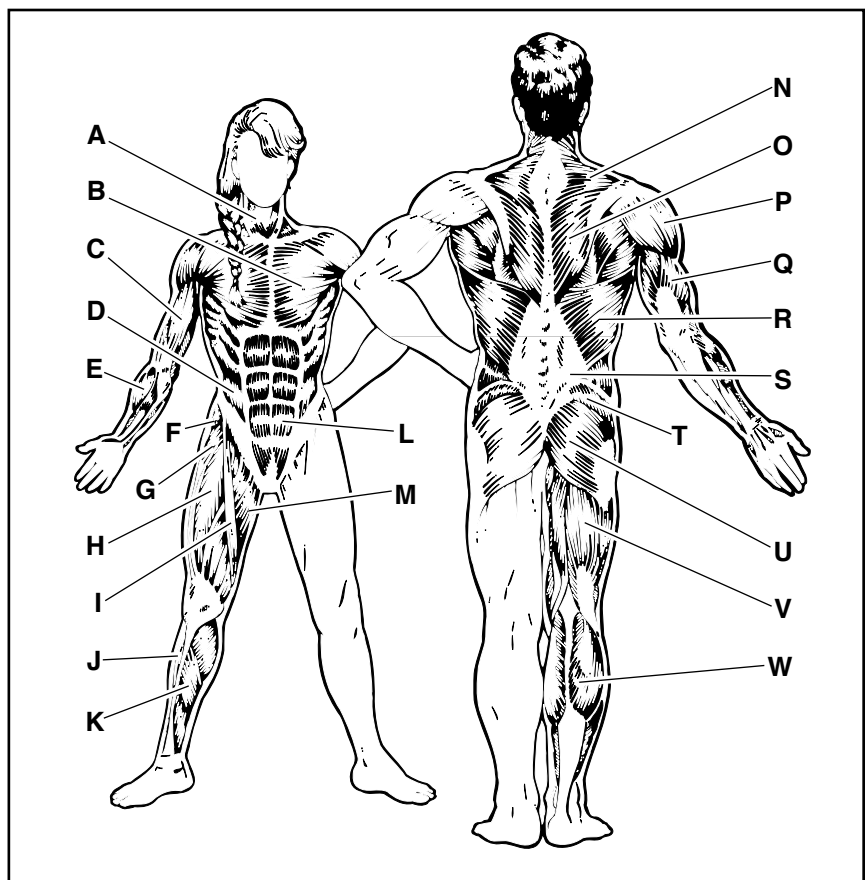

<b>MONDAY</b>	<b>EXERCISE</b>	<b>WEIGHT</b>	<b>SETS</b>	<b>REPS</b>
Date: _____ / _____ / _____				

---

**TUESDAY**      **AEROBIC EXERCISE**  
 Date: \_\_\_\_\_ / \_\_\_\_\_ / \_\_\_\_\_

<b>WEDNESDAY</b>	<b>EXERCISE</b>	<b>WEIGHT</b>	<b>SETS</b>	<b>REPS</b>
Date: _____ / _____ / _____				

---

**THURSDAY**      **AEROBIC EXERCISE**  
 Date: \_\_\_\_\_ / \_\_\_\_\_ / \_\_\_\_\_

<b>FRIDAY</b>	<b>EXERCISE</b>	<b>WEIGHT</b>	<b>SETS</b>	<b>REPS</b>
Date: _____ / _____ / _____				

Make photocopies of this page for scheduling and recording your workouts.

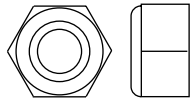

M8 Nylon Locknut (12)—30

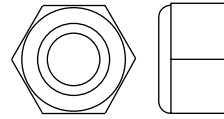

M10 Nylon Locknut (14)—9

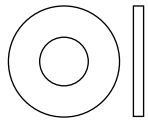

M6 Washer (42)—7

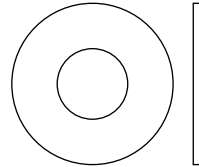

M8 Washer (13)—12

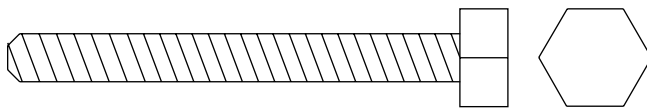

M6 x 60mm Screw (16)—1

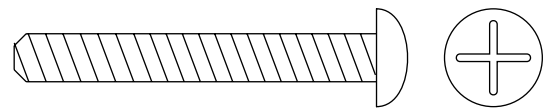

M6 x 48mm Screw (35)—4

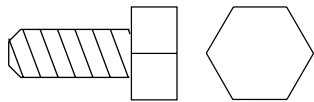

M6 x 16mm Screw (17)—2

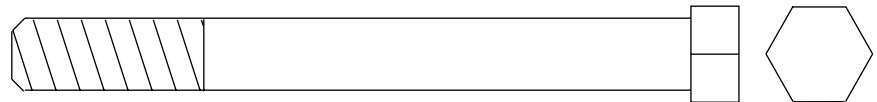

M10 x 90mm Bolt (7)—2

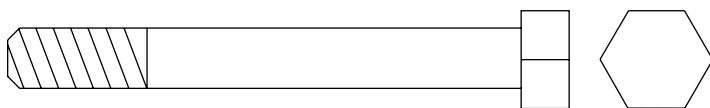

M8 x 68mm Bolt (8)—22

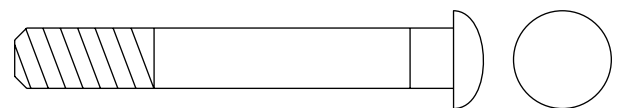

M8 x 58mm Carriage Bolt (6)—8

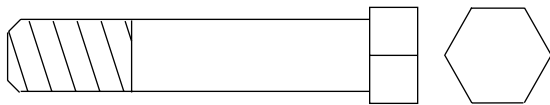

M10 x 48mm Bolt (9)—2

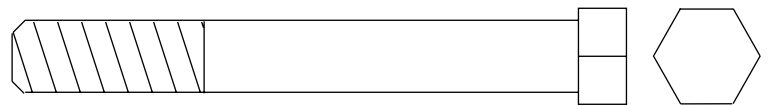

M10 x 75mm Bolt (10)—3

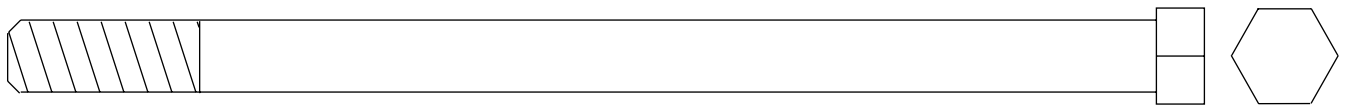

M10 x 152mm Bolt (11)—2

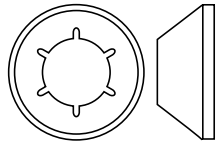

3/8" Dome Cap (3)—2

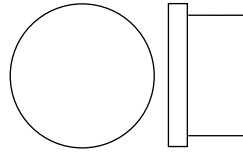

3/4" Round Inner Cap (43)—6

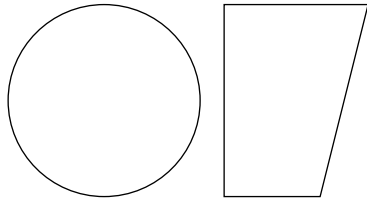

1" Angle Cap (5)—1

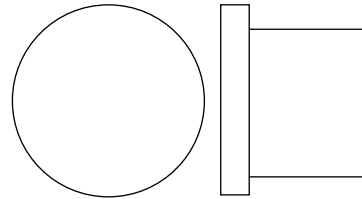

1" Round Inner Cap (41)—11



50mm Square Outer Cap (40)—2

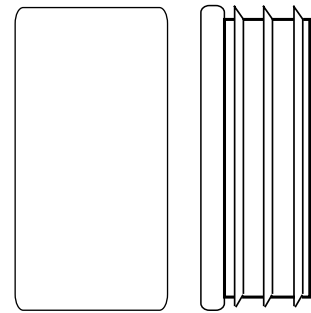

20mm x 40mm Inner Cap (44)—4

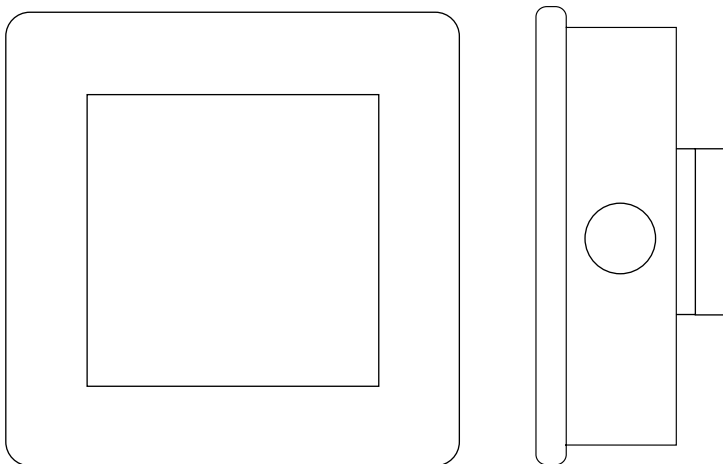

60mm Square Bushing (53)—6

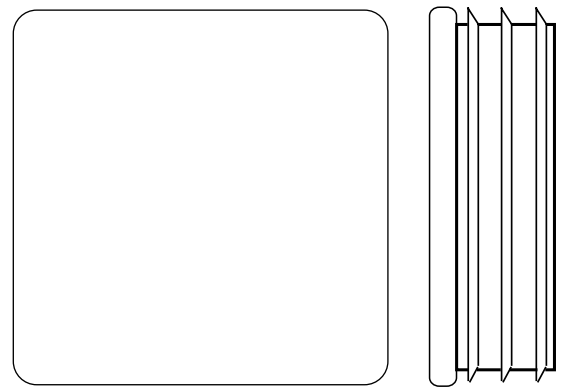

50mm Square Inner Cap (36)—11

# PART LIST—Model No. 831.150471

R0997A

Key No.	Qty.	Part No.	Description	Key No.	Qty.	Part No.	Description
1	1	139870	Spacer Tube	30	2	140222	“U” Bracket
2	2	139871	Foam Grip	31	2	140222	Adjustment “U” Bracket
3	2	139872	3/8” Dome Cap	32	1	140223	Leg Lever
4	2	139873	Spotter Tube	33	1	140224	Stabilizer
5	1	139874	1” Angle Cap	34	1	140225	Seat
6	8	139875	M8 x 58mm Carriage Bolt	35	4	140226	M6 x 48 Screw
7	2	139876	M10 x 90mm Bolt	36	11	140227	50mm Square Inner Cap
8	22	139877	M8 x 68mm Bolt	37	2	140228	Weight Rest
9	2	139878	M10 x 48mm Bolt	38	3	140229	Pad Tube
10	3	130287	M10 x 75mm Bolt	39	1	140230	Top Frame B
11	2	139880	M10 x 152mm Bolt	40	2	140231	50mm Square Outer Cap
12	30	139881	M8 Nylon Locknut	41	11	140232	1” Round Inner Cap
13	12	139882	M8 Washer	42	7	140233	M6 Washer
14	9	139883	M10 Nylon Locknut	43	6	140234	3/4” Round Inner Cap
15	-	-----	Not Used	44	4	140235	20mm x 40mm Inner Cap
16	1	140207	M6 x 60mm Screw	45	4	140236	Cable Spacer
17	2	140208	M6 x 16mm Screw	46	1	140237	“L” Pin
18	2	140209	Front Upright	47	2	140238	Spring Clip
19	2	140210	Rear Upright	48	6	140239	Foam Pad
20	1	140211	Base A	49	1	140240	Bench Frame
21	1	140212	Top Frame A	50	2	140241	Adjustment Bracket Spacer
22	1	141606	Front Leg	51	2	140242	Cable
23	2	140214	Cable Trap	52	2	140243	Weight Carriage
24	2	140215	Pulley	53	6	140244	60mm Square Bushing
25	2	140216	Backrest Tube	54	2	140245	Carriage Stop
26	1	140218	Adjustment Bracket	55	1	140246	Base B
27	2	140219	Handle	#	1	141602	User’s Manual
28	2	140220	Handgrip	#	1	131065	Exercise Poster
29	1	140221	Backrest				

Note: “#” indicates a non-illustrated part. Specifications are subject to change without notice. See the back cover of this manual for information about ordering replacement parts.

# EXPLODED DRAWING—Model No. 831.150471

R0997A

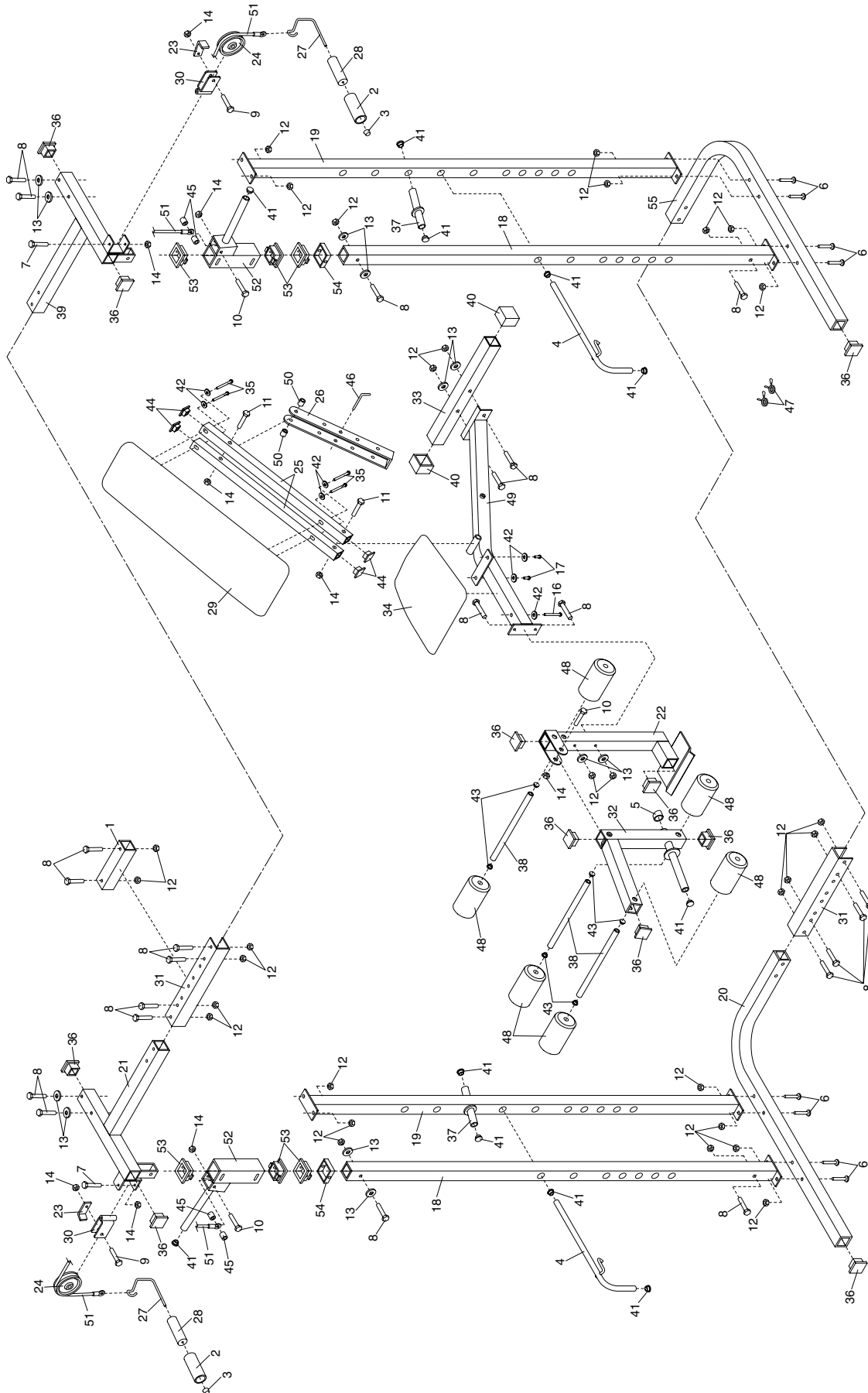



**Model No. 831.150471**

## QUESTIONS?

If you find that:

- you need help assembling or operating the WEIDER® PRO 545
- a part is missing
- or you need to schedule repair service

call our toll-free HELPLINE

**1-800-736-6879**

Monday–Saturday, 7 am–7 pm  
Central Time (excluding holidays)

## REPLACEMENT PARTS

If parts become worn and need to be replaced, call the following toll-free number

**1-800-FON-PART**  
**(1-800-366-7278)**

The model number and serial number of your WEIDER® PRO 545 are listed on a decal attached to the frame. See the front cover of this manual to find the location of the decal.

All replacement parts are available for immediate purchase or special order when you visit your nearest SEARS Service Center. To request service or to order parts by telephone, call the toll-free numbers listed at the left.

When requesting help or service, or ordering parts, please be prepared to provide the following information:

- The MODEL NUMBER of the product (831.150471).
- The NAME of the product (WEIDER® PRO 545 Weight Bench).
- The PART NUMBER of the PART (see the PART LIST and the EXPLODED DRAWING at the center of this manual).
- The DESCRIPTION of the PART (see the PART LIST and the EXPLODED DRAWING at the center of this manual).

## FULL 90 DAY WARRANTY

For 90 days from the date of purchase, if failure occurs due to defect in material or workmanship in this SEARS WEIGHT BENCH EXERCISER, contact the nearest SEARS Service Center throughout the United States and SEARS will repair or replace the WEIGHT BENCH EXERCISER, free of charge.

This warranty does not apply when the WEIGHT BENCH EXERCISER is used commercially or for rental purposes.

This warranty gives you specific legal rights, and you may also have other rights which vary from state to state.

**SEARS, ROEBUCK AND CO., DEPT. 817WA, HOFFMAN ESTATES, IL 60179**