



COFFEE MAKER with BUILT-IN GRINDER

Model number: 169122

UPC: 681131691222

Customer Assistance

1-877-207-0923 (US)

1-877-556-0973 (Canada)



Thank you for purchasing a GE small appliance.

In keeping with the GE ecomagination initiative, please consider the option to recycle the packaging material and donate the appliance you are no longer using.

ecomaginationSM

To read about GE's ecomagination commitment, visit
<http://ge.ecomagination.com>

IMPORTANT SAFEGUARDS

When using electrical appliances, basic safety precautions should always be followed, including the following:

- **READ ALL INSTRUCTIONS BEFORE USING.**
- Do not touch hot surfaces. Use handles or knobs.
- To protect against fire, electric shock and injury to persons do not immerse cord, plug, or in water or other liquid.
- Close supervision is necessary when any appliance is used by or near children.
- Unplug from outlet when not in use and before cleaning. Allow to cooling before putting on or taking off parts, and before cleaning the appliance.
- Do not operate any appliance with a damaged cord or plug or after the appliance malfunctions, or has been damaged in any manner. Call our toll-free Customer Service number for information on examination, repair or adjustment.
- The use of accessory attachments not recommended by the appliance manufacturer may result in fire, electric shock or injury to persons.
- Do not let cord hang over edge of table or counter, or touch hot surfaces.
- Do not place on or near a hot gas or electric burner, or in a heated oven.
- To disconnect, turn any control to "Off", then remove plug from wall outlet.
- Do not set a hot container on a hot or cold surface.
- Do not use a cracked container or a container having a loose or weakened handle.
- Never leave the empty carafe on the warming plate otherwise the carafe is liable to crack.
- Do not clean container with cleaners, steel wool pads, or other abrasive materials.
- Avoid contacting moving parts.
- Blades are sharp. Handle carefully.
- Check the grinder box for presence of foreign objects before using.
- Do not use appliance for other than intended use.
- Do not use outdoors.
- The container is designed for use with this appliance. It must never be used on a range top.
- Unplug from outlet when not in use, before putting on or taking off parts, and before cleaning.

SAVE THESE INSTRUCTIONS!

CONSUMER SAFETY INFORMATION

A short power-supply is provided to reduce risks resulting from becoming entangled in or tripping over a longer cord. Longer extension cords are available and may be used if care is exercised in their use. If a long extension cord is used, the marked electrical rating of the extension cord should be at least as great as the electrical rating of the appliance. The longer cord should be arranged so that it will not drape over the counter top or table top where it can be pulled on by children or tripped over.

This appliance has a polarized plug. To reduce the risk of electric shock, this plug is intended to fit into a polarized outlet only one way. If the plug does not fit fully into the outlet, reverse the plug. If it still does not fit, contact a qualified electrician. Do not attempt to modify the plug in any way.

PARTS

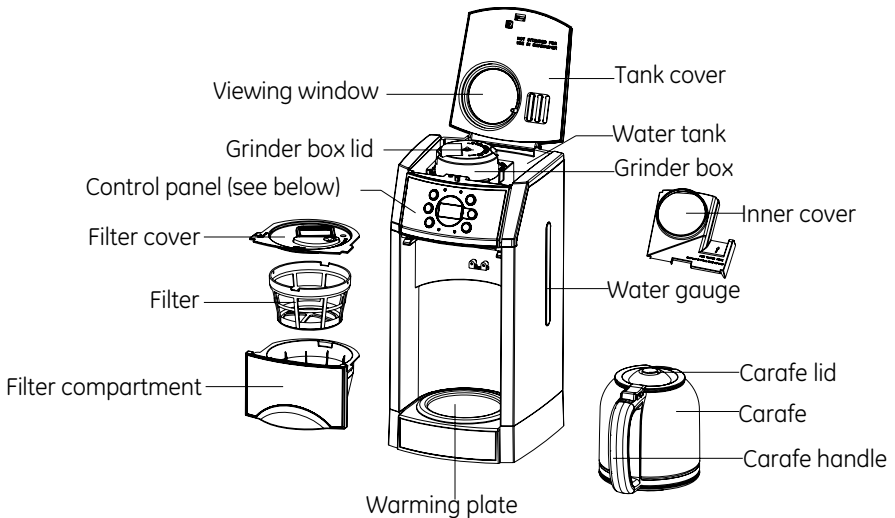

Control panel

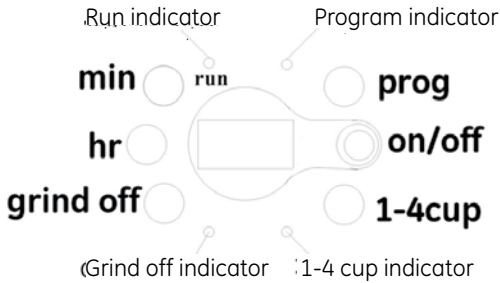

LED display

The top indicator will light for PM.

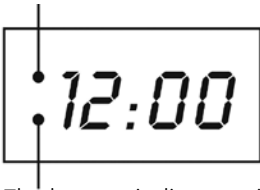

The bottom indicator will light for programmed time.

If the bottom indicator is not lit, the display reads current time.

FEATURES

- Removable filter, filter cover, and permanent filter
- Non-stick warming plate to keep your coffee hot after brewing
- Anti-drip function
- Removable inner cover and grinder box.
- Brew capacity, 10 cups
- Blue LEDs
- Programmable control feature:
 - Clock and Timer
 - Two-Hour Auto Shut Off
 - Delay Brew Function

COFFEE MAKER

Model No.	Rated voltage	Rated power	Capacity	Dimensions	Weight
169122	120V	1000W	1.5L	240.7x206.0x403.3mm	3.9Kg

OPERATING INSTRUCTIONS

Before first use, it is recommended that you run the coffee maker at least 2 times to remove any tiny particles. Fill the water tank to the maximum level mark with fresh water. Insert permanent filter into the filter compartment. Run coffee maker until cycle is complete and dispose of water. Clean all detachable parts completely.

Set the clock

1. Once the appliance is connected to power supply, 18:88 will display and flash on the LED display, after 5 seconds, the LED will display 12:00.

Note: If you do not set the clock, you can go directly to other settings.

2. Press the "program" button once (LED display blinking). You are now in the "Time Set" mode and can operate either "hr" or "min" button. The buttons can be held down to scroll through the digits, or pressed and released lightly to advance one digit at a time.

Note: This coffee maker has an indicator for AM and PM. See diagram of Control Panel.

3. Confirm the clock setting by waiting for 15 seconds.

To set Program Brew function

1. Set the clock.

2. Press the "program" button twice to enter Program Brew function. Enter your desired brew time by pressing the "hr" and "min" buttons.

Note: This coffee maker has an indicator for AM and PM. See diagram of Control Panel.

3. Press the on/off button twice. The program indicator light will be illuminated.

Note: To review Program Brew time, press the "program" button. The lower LED light will be illuminated to indicate program brew is set.

4. If you want to cancel the preset program, press the on/off button twice. The appliance will start to brew immediately.

5. Reset the "automatic start" mode by following steps 1-2 again.

Make Coffee with Whole Beans

1. Add beans: Open the tank cover by pushing the release button and lifting up. Remove inner lid, unscrew the grinder box lid and remove grinder box. Fill the grinder box with the desired quantity of beans according to the marks on the inside of grinder box (see fig.1). Do not fill the grinder box with more than 60g/2 oz. of beans.

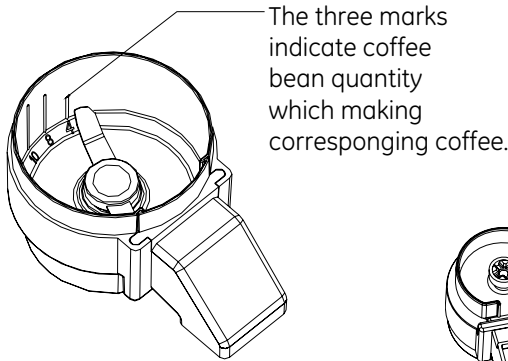

Fig.1

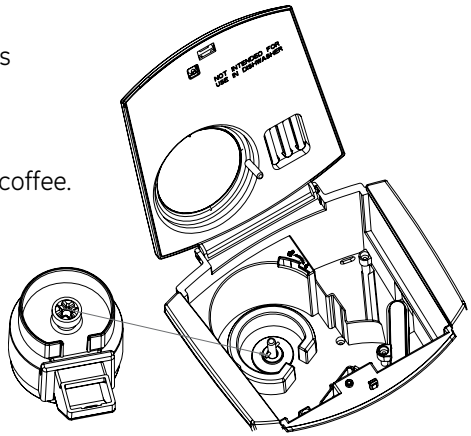



Fig.2

Do not overfill or the grinder box may become blocked and/or the coffee maker may overflow. Place the grinder box back into the coffee maker. Note: the connector groove must be locked into the motor shaft (see fig.2), otherwise the grinder box will not be assembled properly and it may damage the grinder box.

Note: The grinder box must be removed to add beans.

2. Replace the grinder box cover (see fig.3). First place in the “” position, then turn the grinder box lid clockwise until it locks into the “” position, otherwise the appliance will not operate.
3. Fill the tank: Pour the desired amount of water in the tank using the indicator marks on the inside of the cover (see fig.4), and the water level gauge located at the right of the tank.

Note: Before filling water, the inner cover must be assembled in place.

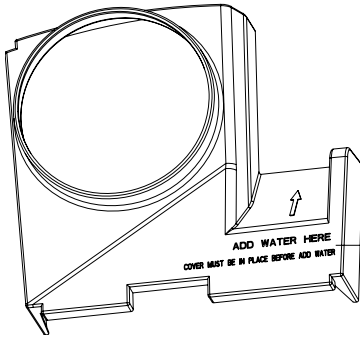
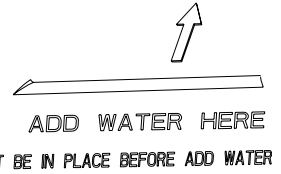

Fig4

Proportions
exaggerated
for clarity



4. Pull out the filter compartment and remove lid. Place the permanent filter in the compartment and replace the inner cover. Then push the filter compartment in place.

Note: The permanent filter may allow some ground coffee to flow into carafe.

5. Close the tank cover. Press down to lock. The appliance is equipped with a safety interlock system.

Note: The appliance will not operate if the tank cover is left open or the grinder box is not in place. If brewing, the brewing will stop. Close the tank cover or reseal the grinder box, then press on/off button to continue operating.

6. Before brewing coffee be sure to place the carafe on the warming plate.

7. Plug the cord into an electrical outlet. "18:88" will display and flash on the LED, after 5 seconds "12:00" will appear until you set the time. Set the clock according to the "Set the clock" section above.

8. Make sure the indicator "grind off" is not illuminated.

Note: If the indicator "grind off" is illuminated, it means that the appliance is on the "make coffee with ground coffee" mode. The appliance will omit the step of grinding beans.

9. Select Cup Setting: The 1-4 cup button is used to control bean grinding time. To make 1-4 cups of coffee, press the button and the 1-4 cup indicator will illuminate (bean grinding time is about 30 seconds). If you do not press the button, the default setting is 5-10 cups and grinding time is about 40 seconds.

Note: The 1-4 cup button can only be used in the "make coffee with beans" mode (indicator below the grind off button will be off). The 1-4 cup function cannot be used with the "make coffee with ground coffee" mode.

10. Start to operate:

- Immediate grinding and brewing: Press the on/off button, the indicator “run” will light and the process will begin.
- Programmed brewing: If you do not want the coffee maker to start operation immediately, you may set the automatic start function according to the “ Set the program time” instructions.

11. When beans finish grinding, the brewing process begins.

Note: During operation, you can take out carafe, pour and serve at any time. The appliance will stop dripping automatically. Replace carafe within 30 seconds to avoid filter basket overflow.

Caution: Upon brewing completion, the unit will produce a large quantity of steam.

12. After brewing, the unit will keep warm for 2 hours and then automatically shut power off or press the on/off button twice to shut power off and unplug the power outlet.

Make Coffee with Ground Coffee

1. Fill the tank: Open the tank cover by pushing the release button and lifting up. Make sure the inner cover is in place. Pour the desired amount of water into the tank according to the water level gauge located on the right side of the unit.

2. Pull out the filter compartment and add ground coffee to the permanent filter. Suggestion: Use 1 level scoop of ground coffee per cup. Adjust the recipe according to individual taste.

Note: The maximum capacity for ground coffee is 10 level scoops. Exceeding that amount may cause overflow if the coffee is too finely ground.

3. Replace the filter cover and push the filter compartment in place.

4. Before brewing coffee, make sure you have set the carafe in its proper position on the warming plate and have placed the filter in the filter compartment and replaced the filter cover.

5. Plug the cord into an electrical outlet. “18:88” will display and flash on the LED, after 5 seconds, “12:00” will appear until you set the time. Set the current clock according to the “**Set the clock**” section on the above.

6. Press the “grind off” button and the grind off indicator will illuminate. The appliance will begin the brewing operation once you press the on/off button or the preset time is reached.

7. Start to operate:

- Immediate brewing: Press the on/off button, the indicator “run” will light and the process will begin.
- Programmed brewing: If you do not want the coffee maker to start operation immediately, you may set the automatic start function according to the “**Set the program time**” instructions.

Note: During operation, you can take out carafe, pour and serve at any time. The appliance will stop dripping automatically. Replace carafe within 30 seconds to avoid filter basket overflow.

8. After brewing, the unit will keep warm for 2 hours and then automatically shut power off or press the on/off button twice to shut power off and unplug the power outlet.

Pause n Serve

This feature allows you to pour a cup of coffee before the entire brew cycle has been completed. By removing the Carafe, the flow of coffee will stop.

Caution: Return carafe to warming plate within 30 seconds. Hot water continues to flow into the filter basket when this feature is used. Overflowing coffee and hot water are a burn hazard.

Automatic shutoff

The Automatic Shutoff feature shuts off the warming plate 2 hours after brew cycle begins. Always turn coffee maker off and unplug when finished.

CLEANING AND MAINTENANCE

Completely clean and dry all detachable parts after every use.

Always turn coffeemaker off and remove the plug from the electrical outlet before cleaning.

1. Remove all detachable parts.
2. Pull out the filter compartment. Remove filter cover and permanent filter.
3. The grinder box, grinder box lid, permanent filter, filter compartment and filter cover can be washed in warm soapy water and rinsed thoroughly, or cleaned in the upper rack of the dishwasher. Dry all parts after every use.
4. Do not put any water in the unit once the grinder box has been removed. Wipe the area under the grinder box with a damp cloth. If water gets into the grinder motor, the motor may become damaged and may malfunction.
5. After cleaning, reassemble all parts.
6. Remove the carafe from the warming plate. Discard any remaining coffee. The carafe and lid can be washed in warm soapy water and rinsed thoroughly, or placed in a dishwasher. The carafe and carafe lid should be placed on the upper rack only.
7. Do not use harsh cleansers on any part of the coffeemaker.
8. Never immerse base unit in water or other liquid. To clean base, simply wipe with a clean, damp cloth and dry before storing.
9. Wipe the warming plate with a clean, damp cloth. Never use rough, abrasive material or cleaners to clean the resting plate.
10. Do not dry the inside of the tank with a cloth, as lint may remain.

TROUBLESHOOTING

During operation, if the water tank cover or grinder box cover are not in place, the motor (if on) will be cut off and the LED display will flash. The LED will display according to the following:

- (1) If the tank cover is not in place, the display will show "OP1".
- (2) If the grinder box is not in place, the display will show "OP2".
 - a. If in the process of grinding beans, replace the grinder box, and close the water tank cover within 5 seconds, the appliance will continue to grind beans, if the time exceed 5 seconds, the appliance will stop.
 - b. If in the process of heating, replace the grinder box and water tank at any time, the appliance will continue to work.

DECALCIFICATION

Decalcification refers to removing the calcium deposits, which form over time on the metal parts of the coffeemaker.

For best performance from your coffeemaker, decalcify the base unit from time to time. The frequency depends upon the hardness of your tap water and how often you use the coffeemaker.

To clean, fill the water reservoir to capacity with a mixture of one part white vinegar and two parts water. Turn the coffeemaker on by pressing the ON/OFF button. One cycle should be sufficient to adequately clean the coffeemaker. When the cycle is completed and the five beeps sound, turn coffeemaker off. Repeat operation, this time using fresh cold water.

CUSTOMER ASSISTANCE

For faster service, please have the model number and product name ready for the operator to assist you. This number can be found on the bottom of your appliance and on the front page of this manual.

Model Number: _____ **Product Name:** _____

Customer Assistance Number 1-877-207-0923 (U.S.) or 1-877-556-0973 (Canada)

Keep these numbers for future reference!

For more information, please visit us at www.gehousewares.com

TWO-YEAR LIMITED WARRANTY

What does your warranty cover?

- Any defect in material or workmanship.

For how long after the original purchase?

- Two years.

What will we do?

- Provide you with a new one.
- For those items still under warranty but no longer available, WAL-MART reserves the right to replace with a similar GE branded product of equal or greater value.

How do you make a warranty claim?

- Save your receipt.
- Properly pack your unit. We recommend using the original carton and packing materials.
- Return the product to your nearest WAL-MART store or call Customer Assistance at 1-877-207-0923 (U.S.) or 1-877-556-0973 (Canada).

What does your warranty not cover?

- Parts subject to wear, including, without limitation, glass parts, glass containers, cutter/strainer, blades, seals, gaskets, clutches, motor brushes, and/or agitators, etc.
- Commercial use or any other use not found in printed directions.
- Damage from misuse, abuse, or neglect, including failure to clean product regularly in accordance with manufacturer's instructions.

How does state law relate to this warranty?

- This warranty gives you specific legal rights, and you may also have other rights which vary from state to state or province to province.
- This warranty is in lieu of any other warranty or condition, whether express or implied, written or oral, including, without limitation, any statutory warranty or condition of merchantability or fitness for a particular purpose.
- WAL-MART, GE and the product manufacturer expressly disclaim all responsibility for special, incidental and consequential damages or losses caused by use of this appliance. Any liability is expressly limited to an amount equal to the purchase price paid whether a claim, however instituted, is based on contract, indemnity, warranty, tort (including negligence), strict liability, or otherwise. Some states or provinces do not allow this exclusion or limitation of incidental or consequential losses so the foregoing disclaimer may not apply to you.

What if you encounter a problem with this product while using it outside the country of purchase?

- The warranty is valid only in the country of purchase and you follow the warranty claim procedure as noted.



is a trademark of General Electric Company and is used under the license by Wal-Mart Stores Inc., Bentonville, AR 72716

Marketed in Canada by:

Wal-Mart Canada Corp.

1940 Argentia Road, Mississauga, Ontario L5N1P9