

SERVICE MANUAL

Heavy Duty Gas Griddles

ITW Food Equipment Group

VULCAN

MODEL *MLS*

24RRG ML-135339-00024

36RRG ML-135340-00036

48RRG ML-135341-00048

60RRG ML-135342-00060

www.vulcanhart.com

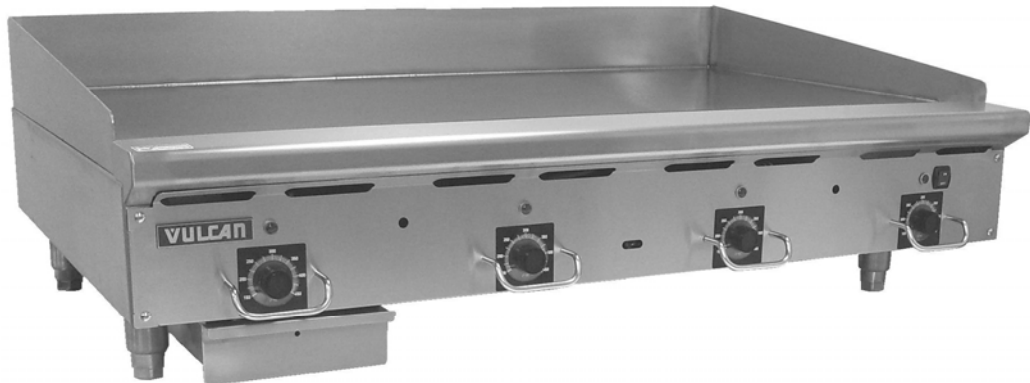

48RRG

ITW Food Equipment Group, LLC
3600 North Point Blvd.
Baltimore, MD 21222

FORM F-36986 (Rev. 11-08)

TABLE OF CONTENTS

INSTALLATION	4
OPERATION	4
CLEANING	4
LUBRICATION	4
SPECIFICATIONS	4
COMPONENT LOCATION	5
CONTROL PANEL	6
BULLNOSE	6
BACK PANEL	6
IDENTIFICATION PLATE	6
FLUE	6
THERMOSTAT	7
THERMOSTAT TROUBLESHOOTING.....	7
SYMPTON-BURNER WILL NOT COME ON.....	7
SYMPTON-GRIDDLE SURFACE TEMPERATURE IS MORE THAN 5° F OFF THERMOSTAT SETPOINT.....	7
THERMOSTAT REMOVAL.....	8
TEMPERATURE PROBE	8
TEMPERATURE PROBE REMOVAL.....	8
TEMPERATURE PROBE INSTALLATION.....	8
ADJUSTMENTS	9
CALIBRATION.....	9
POWER ON/OFF SWITCH	10
POWER SWITCH TROUBLESHOOTING.....	10
SYMPTON-NO POWER SUPPLIED TO UNIT.....	10
POWER SWITCH REMOVAL AND INSTALLATION.....	10
INDICATOR LIGHT	11
INDICATOR LIGHT TROUBLESHOOTING.....	11
SYMPTON-LIGHT DOES NOT COME ON WHEN THERMOSTAT AND BURNER ARE ON.....	11
INDICATOR LIGHT REMOVAL.....	11
SAFETY IGNITION MODULE	11
SAFETY IGNITION MODULE TROUBLESHOOTING.....	12
SYMPTON-NO SPARK BETWEEN PILOT HEAD AND ELECTRODE.....	12
SYMPTON-ELECTRODE CONTINUALLY SPARKS AFTER PILOT IS LIT.....	12
SYMPTON-BURNER SOLENOID VALVE OPENS WITHOUT ESTABLISHED PILOT FLAME.....	12
SAFETY IGNITION MODULE REMOVAL.....	12
SOLENOID VALVES	12
SOLENOID VALVE TROUBLESHOOTING.....	13
SYMPTON-NO GAS FLOW TO BURNER.....	13
SOLENOID VALVE REMOVAL.....	13
PILOT	14
PILOT TROUBLESHOOTING.....	14
SYMPTON-PILOT WILL NOT LIGHT.....	14
PILOT ASSEMBLY REMOVAL.....	14

BURNER	15
BURNER TROUBLESHOOTING.....	15
BURNER REMOVAL.....	15
BURNER ADJUSTMENT.....	16
GAS REGULATOR	17
REGULATOR TROUBLESHOOTING.....	17
SYMPTOM-UNIT WILL NOT MAINTAIN CONSISTENT GAS PRESSURE.....	17
GAS PRESSURE MEASUREMENT	17
PRESSURE TAP LOCATION.....	18
SEQUENCE OF OPERATION	18
WIRING DIAGRAMS	19
24-INCH GRIDDLE.....	19
36-INCH GRIDDLE.....	20
48-INCH GRIDDLE.....	21
60-INCH GRIDDLE.....	22

GENERAL

INTRODUCTION

This manual is prepared for the use of trained service technicians and should only be used by those who are properly qualified. This manual is not intended to be all encompassing. You should read, in it's entirety, the repair procedure you wish to perform to determine if you have the necessary tools, instruments and skills required to perform the procedure. Procedures for which you do not have the necessary tools, instruments and skills should not be attempted.

⚠ WARNING Disconnect the electrical power and follow lockout / tagout procedures

⚠ WARNING Certain procedures in this manual require electrical test or measurements while power is applied to the machine. Exercise extreme caution at all times when attempting these procedures. Before testing, disconnect electrical power and follow lock/out tagout procedures, then attach test equipment and reapply power to test.

Procedures in this manual will apply to all RRG models unless specified. No procedure in this manual will require the removal or raising of the griddle plate. Pictures and illustrations can be of any model unless the picture or illustration needs to be model specific.

INSTALLATION

Generally, installations are made by the dealer or contracted by the dealer or owner. Detailed installation instructions are included in the Installation and Operation Manual that is sent with each unit. However, it should be noted that an improperly installed unit, especially an unlevel unit can lead to premature electrical component failures. A unit that is higher in the front will cause the flue gases to vent improperly and gather in the front near the electrical components. All RRG models must be installed with an externally mounted regulator.

OPERATION

Detailed operation instructions are included in the Installation & Operation Manual sent with each unit and are also available at WWW.VULCANHART.COM.

CLEANING

Detailed cleaning procedures are included in the Installation & Operation manual sent with each unit.

LUBRICATION

No lubrication is required on this equipment.

SPECIFICATIONS

All RRG models operate on 120 volt, 60 hertz, single phase at 1.0 amps. All models are equipped with electric solid state thermostats, automatic spark igniters and pilot safety circuit. All models are equipped with 27,500 BTU/HR burners as standard equipment. One burner is used for every 12 inches of griddle surface. Natural gas models are to operate at 5.0" W.C. manifold pressure and LP models at 10.0" W.C. manifold pressure with all burners on.

COMPONENT LOCATION

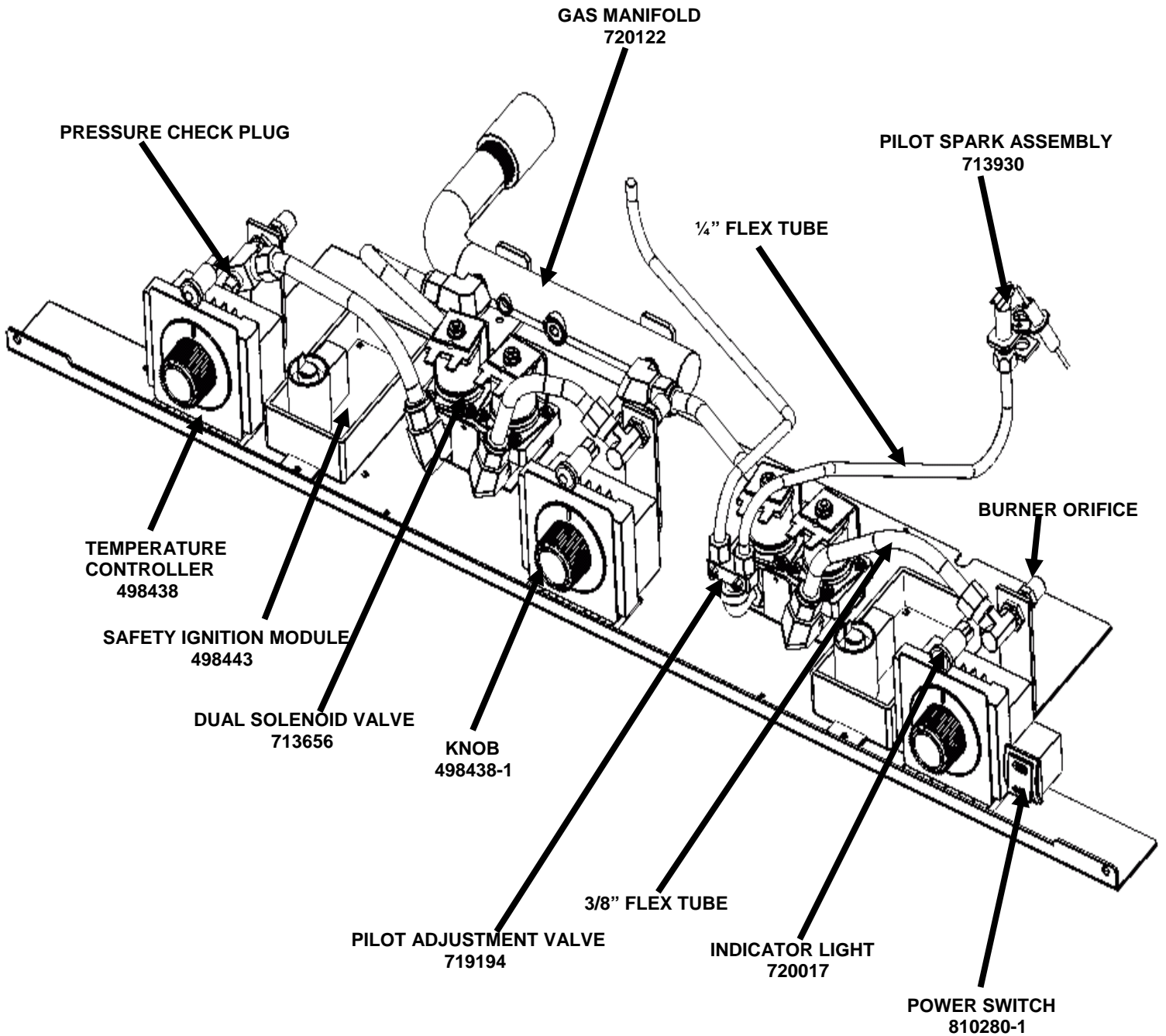

36RRG CONFIGURATION SHOWN

EXTERIOR PANELS

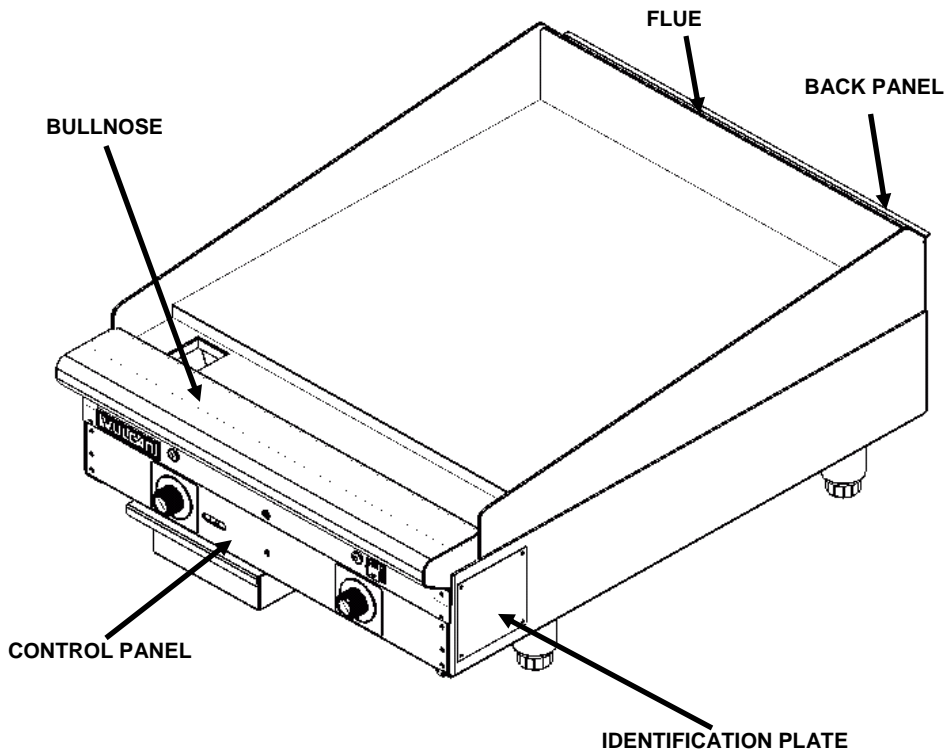

BACK PANEL

⚠ WARNING Disconnect the electrical power and follow lockout / tagout procedures

It will be necessary to remove the back panel when changing a burner, temperature probe or to remove excessive grease build up from the flue area.

REMOVAL

1. Disconnect gas supply at griddle.
2. Remove all screws from rear of griddle securing the back panel.
3. Reverse the procedure to install.

IDENTIFICATION PLATE

The identification plate contains the unit's full model and serial number along with BTU rating and clearance information. The identification plate is located on the right side panel towards the front of the unit.

FLUE

The flue is the outlet for gases left over from combustion and excess heat. The flue should never be blocked or covered.

CONTROL PANEL

⚠ WARNING

Disconnect the electrical power and follow lockout / tagout procedures

The Control Panel holds the thermostats, indicator lights and power switch.

REMOVAL

1. Remove the four screws securing the front of the control panel. There are two screws at each end of the panel.
2. Remove the screws that secure the bottom of the control panel to the underside of the chassis.
3. Pull the control panel forward and lay face down directly in front of the unit while servicing.
4. Reverse the procedure to install.

BULLNOSE

⚠ WARNING

Disconnect the electrical power and follow lockout / tagout procedures

The Bullnose acts as a front rail or shelf during griddle operation.

REMOVAL

1. Remove the Control Panel.
2. The bullnose assembly is secured with several screws, one at each end of the bottom of the assembly and several more (depending on size) facing the griddle plate.
3. Reverse the procedure to install.

THERMOSTAT

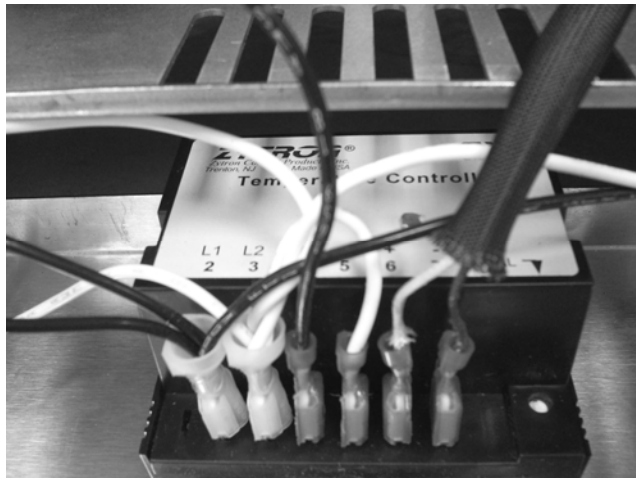

WIRING CONFIGURATION



FRONT VIEW

The thermostat is a solid state control. The thermostat supplies power to the burner solenoid valves and indicator lights when turned on or until the temperature setpoint is reached.

⚠ WARNING Disconnect the electrical power and follow lockout / tagout procedures

THERMOSTAT TROUBLESHOOTING

SYMPTOM – BURNER WILL NOT COME ON

1. Check for loose or excessively greasy/dirty connections at thermostat terminals
2. Check that thermostat is set higher than griddle plate surface temperature.
 - A. Check for 120 voltage going to L1 terminal on thermostat
 - B. If no voltage, check wiring and power switch.
3. Check safety ignition module.
4. Check for resistance (approx. 50 Ω) from L2 wire to ground when safety circuit should be made.
 - A. If no resistance, check that pilot is lit and check safety ignition module.

SYMPTOM – GRIDDLE SURFACE TEMPERATURE IS MORE THAN $\pm 5^{\circ}\text{F}$ OF THERMOSTAT SET POINT

1. Ensure that you are using a high quality, calibrated surface temperature measuring device.
 - A. Do not use an infrared thermometer – these are highly inaccurate on a griddle plate.
 - B. Refer to instructions on page 8 for proper placement of probe and method.
2. Check that burners are properly adjusted.
3. Check that burner valves are operating correctly.
4. Check that there are no burner orifice obstructions
5. Check that the high temp. thermostat probe wire insulation is completely covering the wire. If you have found no problems in steps 1 – 5, proceed page 9 for calibration instructions.
6. If thermostat will not calibrate after all previous steps – replace thermostat.

⚠ WARNING Disconnect the electrical power and follow lockout/tagout procedures

THERMOSTAT REMOVAL

1. Remove the control panel
2. Remove the knob
3. Label and disconnect the wires
4. Remove the thermostat retaining nut on the knob shaft.
5. Reverse procedure to install while being careful to install the thermostat in the same orientation.

TEMPERATURE PROBE

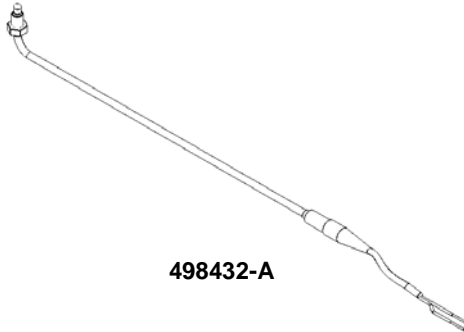

The temperature probe is an embedded K type thermocouple assembly.

⚠ WARNING Disconnect the electrical power and follow lockout/tagout procedures

TEMPERATURE PROBE REMOVAL

1. Remove the control panel
2. Remove the back panel
3. Label and disconnect the lead wires at the temperature controller
4. Unthread the probe retaining nut and remove the probe from the back of the unit.



TEMPERATURE PROBE INSTALLATION

1. Insert lead wires from back of heatshield through to temperature controller.
2. Apply a thin coating of high temp(500° F min. rated),copper based heat transfer and anti-seize compound to the probe tip and retaining nut.
3. Insert probe end into plate socket and hand tighten probe retaining nut.
4. Tighten the probe an additional ½ turn only with a wrench. Over tightening can strip threads and damage probe tip.

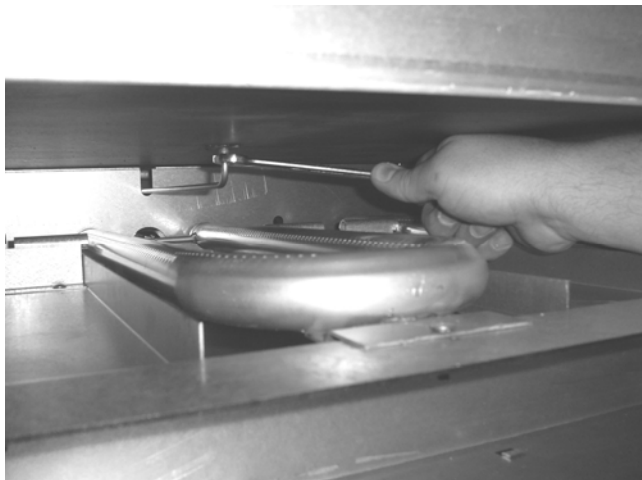

ADJUSTMENTS

CALIBRATION

- Each temperature controller controls a 12" zone of the griddle. Using a Surface Probe temperature measurement device, observe the temperatures at the center points of the cooking zones. These points are located by starting 6" from the side splash (left or right) and every 12" across the width of the griddle, with all points located 12" back from the front edge of the griddle plate.

NOTE: Use of infrared thermometers is not recommended. These devices are highly sensitive to surface color (clean or dirty), angle of reading and distance from the unit.

- Set thermostats to 350°F and allow to stabilize, allowing the indicator light to cycle ON and OFF at least two times.
- Watch for indicator light to cycle OFF, then measure the temperature for that zone. The temperature should be 350°F ±5°F. If not, continue to Step 4.

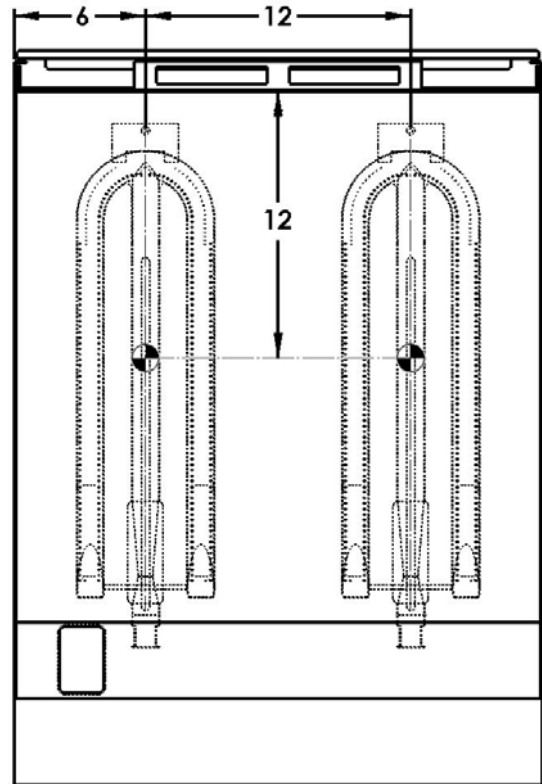

- Set the temperature controller to 350° F. DO NOT allow the knob to turn. Carefully remove the knob from the temperature control shaft.
 - Loosen screws on the back of knob and turn the transparent ring around the black knob to the desired position. Knob will have to be placed back on the shaft to verify adjustment.



Step 4a. Set knob & check temperature. Remove knob

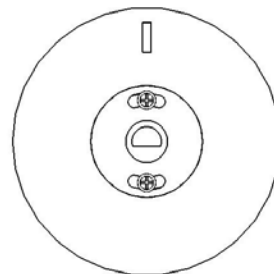

Step 4b. – Adjust the position of outer knob ring relative to black knob body & verify temperature setting

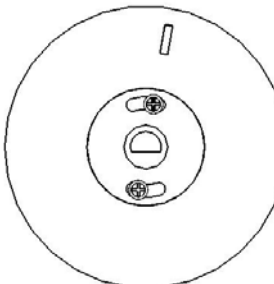

Step 4c. –Replace knob and verify the reading. Carefully remove the knob & tighten screws

IMPORTANT: NEVER ADJUST THE SCREW ON THE BACK SIDE OF THE TEMPERATURE CONTROLLER. This will ruin the factory calibration; the temperature controller will no longer operate properly and will need to be replaced.

- Once calibration is achieved, tighten the knob screws.

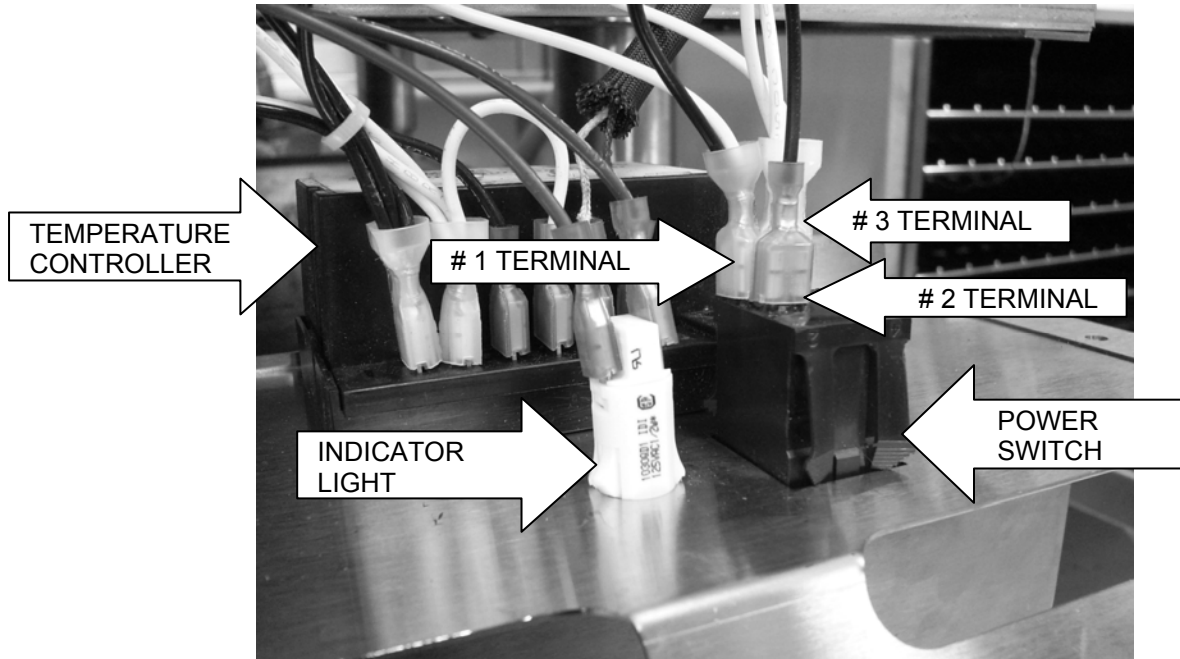

POWER ON/OFF SWITCH

The Power Switch controls the power supply to all other electronic components.

⚠ WARNING Disconnect the electrical power and follow lockout / tagout procedures

POWER SWITCH TROUBLESHOOTING

SYMPTOM – NO POWER BEING SUPPLIED TO THE UNIT

1. Check for loose or excessively greasy/dirty connections at terminals.
2. With power wires disconnected check for continuity/resistance between the 1 and 2 terminals
 - A. If continuity/resistance with switch in OFF position – replace switch
 - B. If no continuity/no resistance with switch in ON position – replace switch
3. Check for 120 voltage from #2 terminal to ground
 - A. If no voltage – check main wiring from j box and power cord/plug
 - B. If getting voltage to #2 terminal – check voltage to #1 terminal to ground with switch in “on” position.
 1. If no voltage – replace switch

POWER SWITCH REMOVAL

1. Remove the control panel.
2. Label and disconnect the wires to the power switch.
3. Squeeze the switch retainers and slide the switch out through the front of the control panel.
4. Reverse the procedure to install and check for operation.

INDICATOR LIGHT

The indicator light illuminates fully to indicate that the corresponding thermostat and burner have turned on and gas is flowing through the corresponding solenoid valve. The indicator light will illuminate at a lower intensity when the pilot safety circuit is being made (pilot lit) but the corresponding burner solenoid valve and thermostat are not on. The indicator light will exhibit no illumination if the pilot safety circuit is not made (pilot not lit).

INDICATOR LIGHT TROUBLESHOOTING

SYMPTOM – LIGHT DOES NOT COME ON WHEN THERMOSTAT AND BURNER ARE ON.

1. Check for loose or excessively greasy/dirty terminal connections
2. Check for approx. ½ line voltage between the two indicator light terminals with the corresponding burner and thermostat off.
 - A. If no voltage – check wires coming in from the corresponding safety ignition module to the solenoid to the light for shorts or breaks.
3. With thermostat on and corresponding burner lit – check for 120 voltage between both wires at the light.
 - A. If no voltage – check wires coming from the corresponding thermostat to the solenoid to the light for shorts or breaks. Check thermostat and safety ignition module
 - B. If you have 120V – replace indicator light.

⚠ WARNING Disconnect the electrical power and follow lockout / tagout procedures

INDICATOR LIGHT REMOVAL

1. Remove the control panel
2. Label and disconnect wires to the light
3. Squeeze the light retainers and slide the light out through the front of the control panel
4. Reverse the procedures to install and check for proper operation

SAFETY IGNITION MODULE



The safety ignition module is a direct spark ignition control that utilizes a microprocessor circuit for ignition and flame sensing. The flame sensing is achieved via flame rectification. The unit will continue to spark and keep the corresponding solenoid valves locked out until a minimum flame current of 1.0 μ A is achieved.

Pin 1

Pin 2

Pin 3

Pin 4

⚠ WARNING Disconnect the electrical power and follow lockout / tagout procedures

SAFETY IGNITION MODULE TROUBLESHOOTING

SYMPTOM – NO SPARK BETWEEN PILOT HEAD AND ELECTRODE

1. Check for loose or greasy/dirty connections at all terminals (including electrode wire)
2. Check for 120 voltage from pin 4 wire to ground.
 - a. If no voltage check on/off switch and wiring for shorts or breaks
3. Check electrode wire for damage and continuity – if damaged or no continuity change spark/pilot assembly
 - a. Check spark gap between electrode and pilot head. The spark gap should be between .094” to 0.156” – or approx. 1/8”.
4. If component has passed above checks and is not sparking – then replace ignition module.

SYMPTOM – ELECTRODE CONTINUALLY SPARKS AFTER PILOT IS LIT

1. Check that electrode is engulfed by pilot flame
2. Increase pilot flame height
3. Check electrode and electrode wire for damage
4. Check that power cord grounding wire is securely attached to J box.
5. Check that ground wire from pin 1 is securely grounded to chassis.

SYMPTON – BURNER SOLENOID VALVE OPENS WITHOUT ESTABLISHED PILOT FLAME

1. Check burner solenoid valve.
2. Check for voltage from pin 2 wire of safety ignition module
 - a. Replace safety ignition module if voltage

IGNITION MODULE REMOVAL

1. Remove the control panel.
2. Label and disconnect the wires from the igniter module.
3. Disconnect the electrode wire and control wire harness.
4. Remove the two mounting bolts.
5. Remove the safety ignition module.
6. Reverse the procedure to install and check for proper operation.

SOLENOID VALVES

The RRG series griddles use both single and dual solenoid valves in differing applications. A single or dual valve can be either a pilot valve or main burner valve. Pilot valves can be identified by the fact that they will have adjustment screws for the pilot flame at the output of the valve body. Pilot solenoid valves will receive power and remain on as long as the power switch is in the ON position. Main burner solenoid valves will remain on until the thermostat set point has been satisfied.

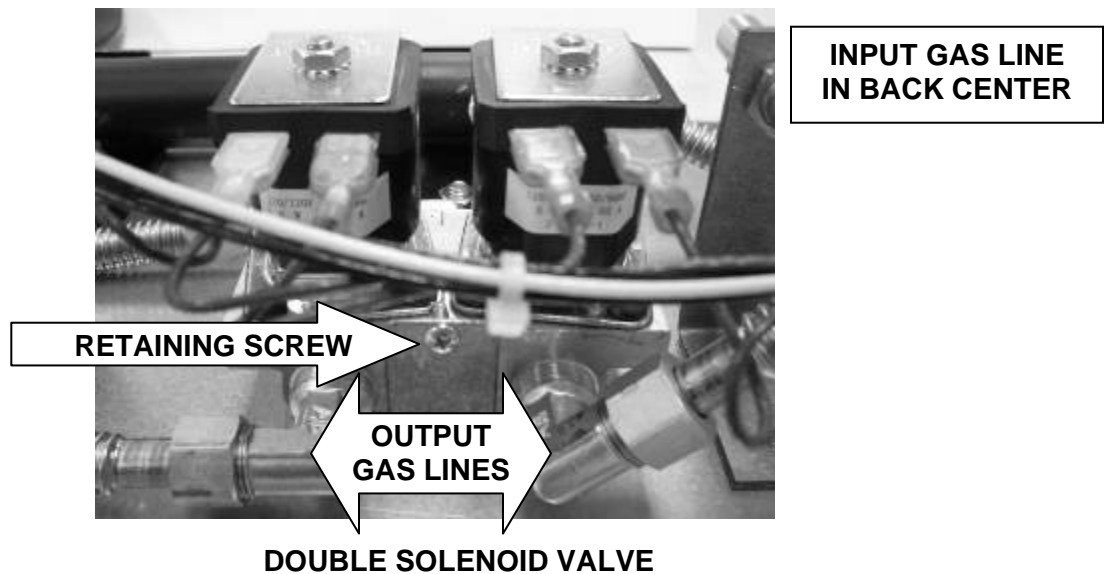

⚠ WARNING Disconnect the electrical power and follow lockout / tagout procedures

SOLENOID VALVE TROUBLESHOOTING

SYMPTOM – NO GAS FLOW TO BURNER

1. Check terminals for loose or greasy/dirty connections
2. Check gas pressure – check for orifice obstructions.
3. With thermostat, indicator light and power switch on – check for 120 voltage between the two terminals on the solenoid.
 - A. On pilot solenoid if no voltage – check wiring and on/off power switch
 - B. On main burner solenoid if no voltage – check wiring, safety ignition module and thermostat
4. If you have 120 voltage between the two terminals after performing steps 1- 3, replace the solenoid valve.
5. Check for a shorted coil by checking resistance between the two terminals with the wires disconnected. Readings of 100 ohms or less would indicate a shorted coil, replace the solenoid.

SOLENOID VALVE REMOVAL

⚠ WARNING Shut off gas supply

1. Remove the control panel.
2. Label and disconnect the wires to the solenoid terminals.
3. Remove the two retaining screws that are holding the valve body in the bracket.
4. Disconnect the input compression fitting and the output compression fitting(s).
5. Remove the solenoid valve
6. Reverse the procedure to install. Be careful to attach the input lines to the ports on the valve body that are stamped IN
7. Verify gas pressure and check for proper operation.

⚠ WARNING All gas joints disturbed during servicing must be checked for leaks. Check with a soap and water solution. Do not use an open flame.

PILOT

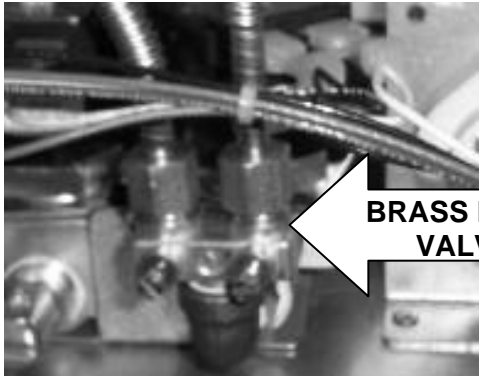

BRASS PILOT VALVE

The RRG Series Griddles utilize a solenoid valve with a brass pilot valve to control gas flow to pilot burners. One to three pilot flames can be fed by one valve – one leg of which may be branched.

PILOT TROUBLESHOOTING

SYMPTOM – PILOT WILL NOT LIGHT

1. Check pilot adjustment at solenoid valve
2. Check that power switch is on
3. Check that pilot solenoid valve is working
4. Check that safety ignition module and power switch are working
5. Check gas pressure
6. Check for air in the line

PILOT ASSEMBLY REMOVAL

⚠ WARNING Disconnect the electrical power and follow lockout / tagout procedures

⚠ WARNING Shut off gas supply

1. Remove control panel. Reaching underneath the front of the unit, remove the pilot tube fitting and disengage the pilot tube from the pilot.
2. Reaching underneath the front of the unit, remove the pilot bracket retaining screw(#2 Phillips) and remove the entire assembly out through the pilot access cutout and out from under the unit.
3. Disconnect the electrode wire from the from the safety ignition module.
4. Remove the pilot from the bracket.
5. Reverse procedure to install
6. Verify gas pressure and check for proper operation

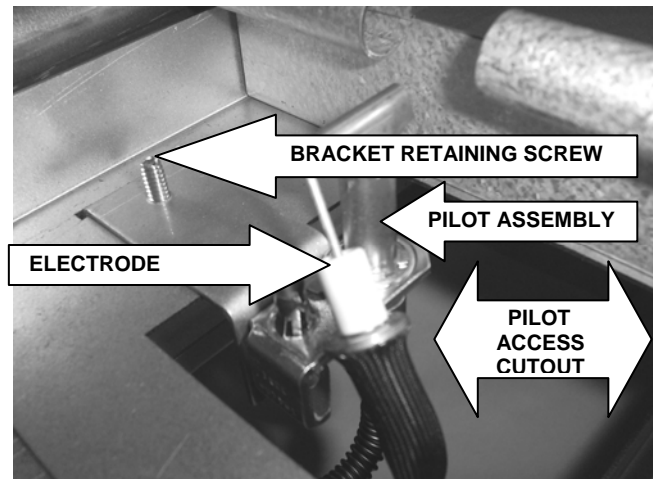

⚠ WARNING All gas joints disturbed during servicing must be checked for leaks. Check with a soap and water solution. Do not use an open flame.

HELPFUL HINT – If the unit is attached to a flexible gas line, you can extend the bullet feet out to their fullest extension to raise the griddle and allow yourself more clearance while reaching under the unit. Remember to relevel the unit if you chose to do this.

BURNER

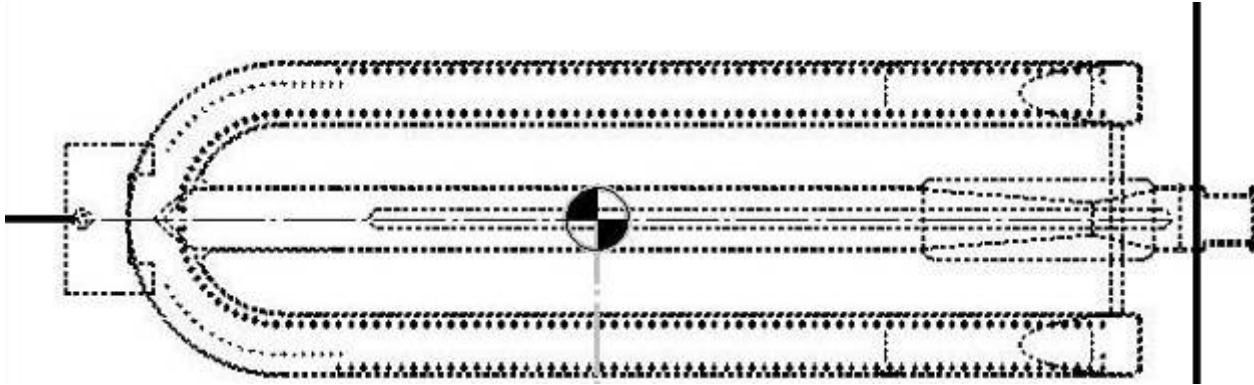

The RRG Series Griddle utilizes U-shaped burners with a single center inlet for every 12 inches of griddle width. Each burner is rated for 27,500 BTU/hr.

⚠ WARNING Disconnect the electrical power and follow lockout / tagout procedures

BURNER TROUBLESHOOTING

SYMPTOM – ALL BURNERS HAVE A LOWER OR HIGHER FLAME THAN NORMAL.

1. Check gas pressure

SYMPTOM – ONE OR MORE BURNERS HAVE LOWER FLAME LEVEL THAN THE OTHERS.

1. Check gas pressure
2. Check burner orifice for obstructions
3. Adjust burner air shutter
4. Check solenoid valve

SYMPTOM – ONE BURNER HAS A DELAYED IGNITION; A SEVERAL SECOND LAPSE BETWEEN THE INDICATOR LIGHT TURING ON AND WHEN THE BURNER ACTUALLY LIGHTS.

1. Check gas pressure
2. Check that burner locator pin is properly seated with retaining clip attached
3. Check that burner ignition ports, pilot flash tube and pilot burner are all aligned.
4. Check burner shutter adjustment
5. Check pilot flame adjustment
6. Check thermostat, safety ignition module and solenoid valve operation.

BURNER REMOVAL

⚠ WARNING Shut off gas supply

1. Remove the back panel

2. Reach through the back of the unit. Squeeze the burner retaining clip and slide off burner retaining pin.
3. Lift the burner up so the retaining pin clears the corresponding hole in the chassis, then pull the burner out through the back of the unit.
4. Replace by inserting the burner through the rear of the unit and engaging the burner venturi onto the burner orifice at the front of the unit.
5. Seat the retaining pin in the hole in the chassis and attach the retaining clip.
6. Remove the control panel to check that the venturi is properly fitted over the orifice.
7. Reassemble the control and back panels, then check for proper operation.

BURNER ADJUSTMENT

For efficient burner operation, it is important that a proper balance of gas volume and primary air supply is maintained to give complete combustion. Insufficient air supply results in a yellow streaming flame. Primary air supply is controlled by the air shutter on the front of the burner venturi. Loosen the screw on the venturi and adjust the air shutter to just eliminate yellow tips on the burner flames. Lock the air shutter in place in place by tightening the screw. Repeat this procedure as necessary with all burners.

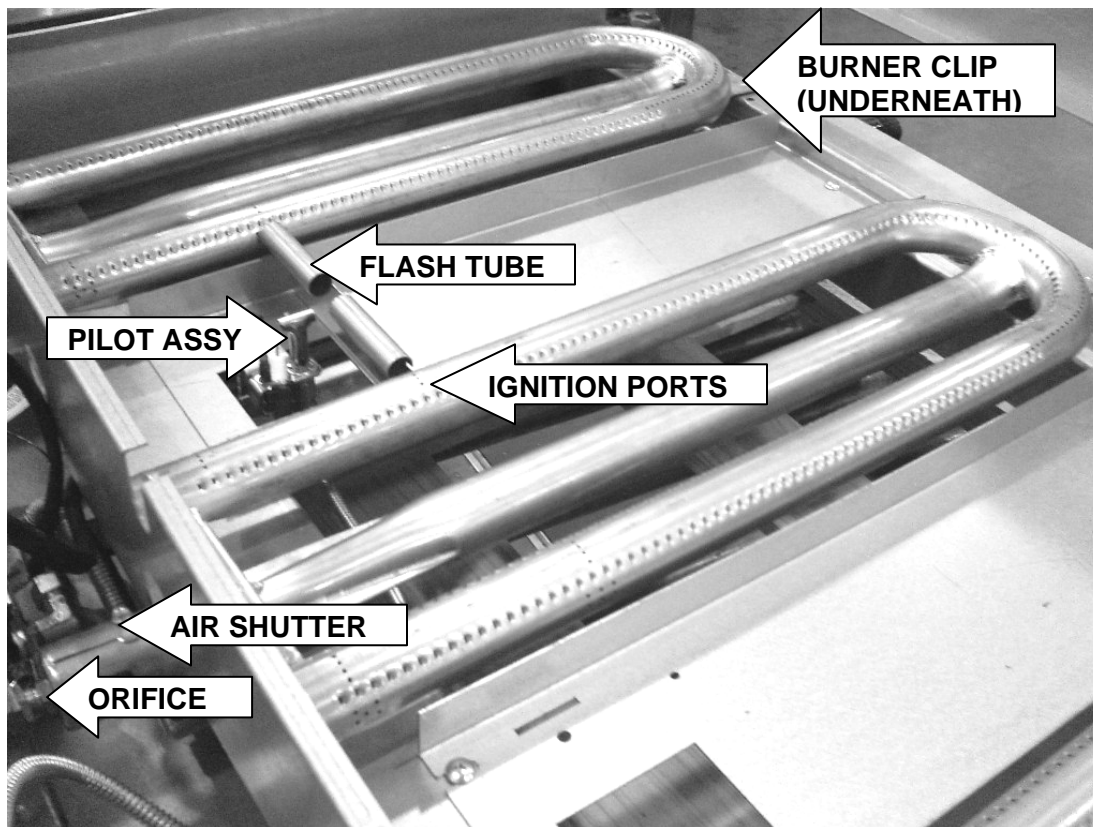

These photos are for reference – it should not be necessary to remove the griddle top to perform the procedures listed in this manual.

GAS REGULATOR

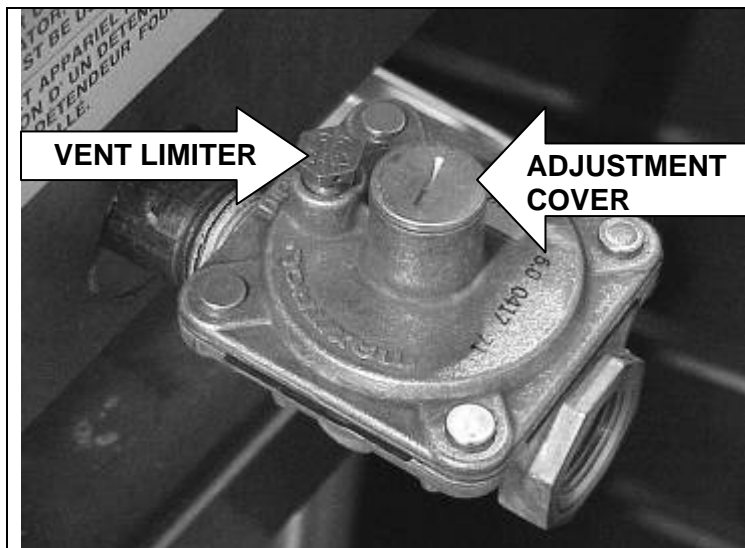

REGULATOR INSTALLED IN A HORIZONTAL, UPRIGHT POSITION

The RRG series units must have an exterior machine gas regulator installed. The units are shipped with a regulator that has a vent limiter. These regulators must be installed as close as possible to the unit in a horizontal, upright position for optimal performance. They are adjusted by removing the adjustment cover – then by turning the adjustment screw clockwise to increase and counter clockwise to decrease. The regulator and griddle can be damaged by gas pressures that exceed 14" W.C. or ½ psig.

Natural Gas Regulator 408279-25
LP Gas Regulator 408279-21

REGULATOR TROUBLESHOOTING

SYMPTOM – UNIT WILL NOT MAINTAIN CONSISTENT PRESSURE

1. Check that vent limiter is not clogged by grease and debris
2. Check store gas pressure before regulator with all equipment on that line turned on and consuming gas
 - A. For natural gas should be between 7" and 14" W.C.
 - B. For propane gas should be between 12" and 14" W.C.
3. Check that regulator is installed in a horizontal, upright position
4. If no problems found in steps 1 – 3, replace the regulator

GAS PRESSURE MEASUREMENT

1. Set the power on/off switch to the OFF position.
2. Turn the gas supply off at a manual shutoff valve.
3. Remove the control panel.
4. Remove the pressure tap plug from the far left/#1 burner port and attach manometer
5. Turn gas back on and turn power switch to the ON position
6. Turn all thermostats on to the maximum setting so that all burners are on.
7. Turn all the equipment on the same supply line on.
8. Check gas pressure
9. Gas pressure should read 5" W.C. for natural and 10" W.C. for propane gas.
10. Turn off the power switch.
11. Turn gas supply off, disconnect manometer and reinstall pressure tap plug.

12. Turn power switch and gas supply back on.

⚠ WARNING All gas joints disturbed during servicing must be checked for leaks. Check with a soap and water solution. Do not use an open flame.

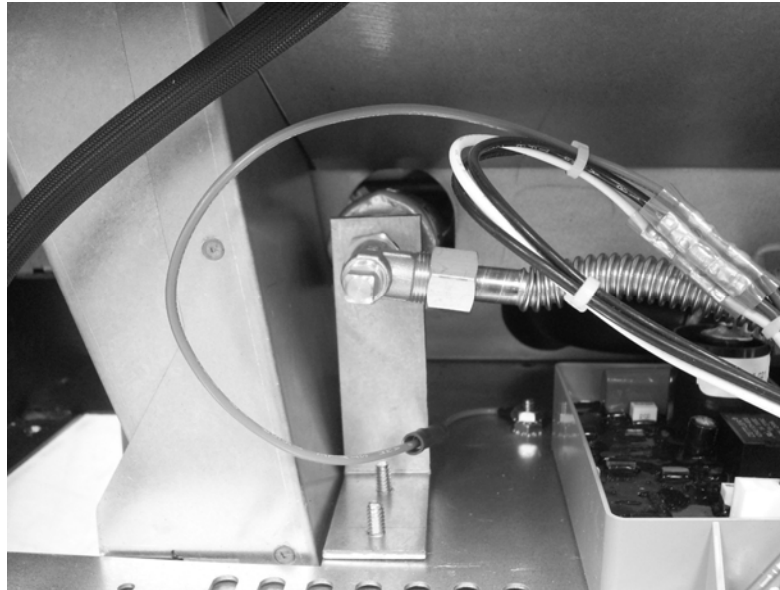

PRESSURE TAP AT #1 BURNER

SEQUENCE OF OPERATION

Operation is the same for all size griddles. The neutral wire from the power source is directly connected to each thermostat and each safety ignition module.

1. The power on/off switch is set to the ON position.
2. Voltage is applied to the following terminals
 - A. Terminal L1 on each thermostat.
 - B. Pin 4 terminal of each safety ignition module.
 - C. Both terminals of the pilot solenoid – energizing the solenoid.
3. The igniter electrode sparks against the pilot head and lights the pilot burner
4. When the pilot flame is sensed – the igniter stops sparking and the igniter safety module allows voltage to pass to one terminal of each of the corresponding burner solenoid valves and one terminal of each indicator light – the indicator light illuminates at dim.
5. If the griddle plate temperature is lower than the thermostat set points - the thermostat(s) will send voltage to the remaining burner solenoid terminal and remaining indicator light terminal.
 - A. The solenoid will then energize - gas flows to the corresponding burner and is ignited by the pilot flame.
 - B. The corresponding indicator light will go from dim to full illumination.

WIRING DIAGRAMS

WIRING DIAGRAM – 24-INCH GRIDDLE

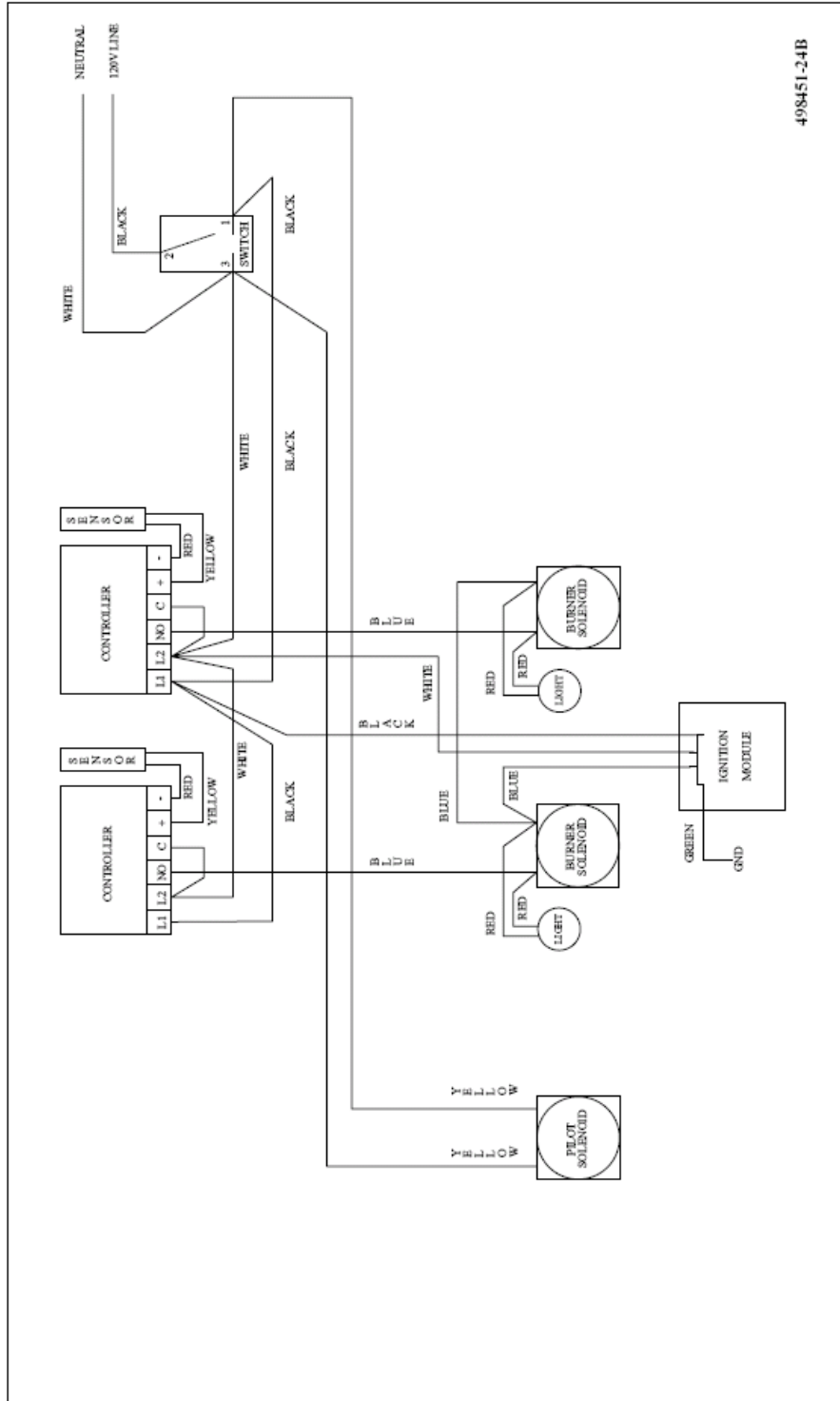

498451-24B

WIRING DIAGRAM – 36-INCH GRIDDLE

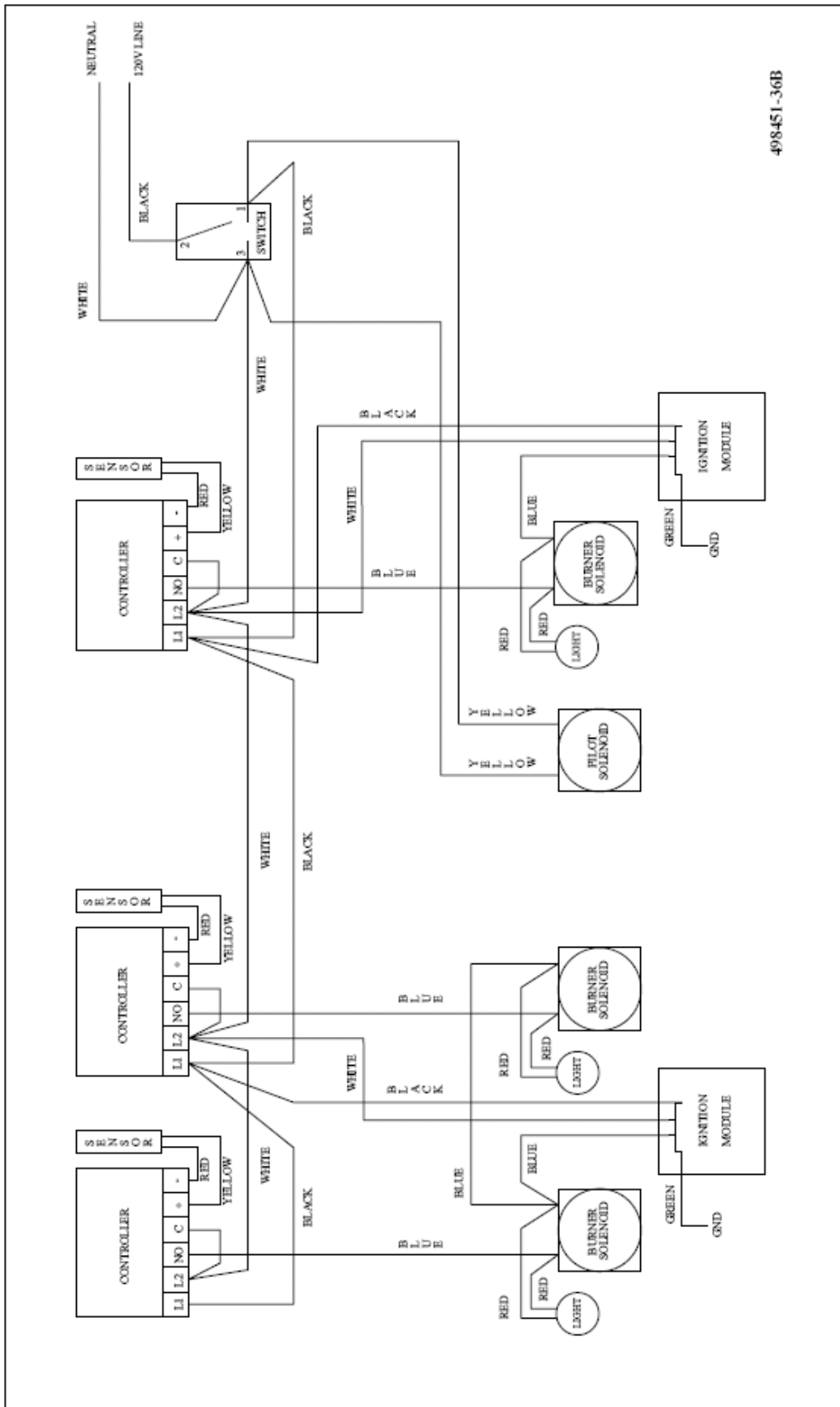

498451-36B

WIRING DIAGRAM – 48-INCH GRIDDLE

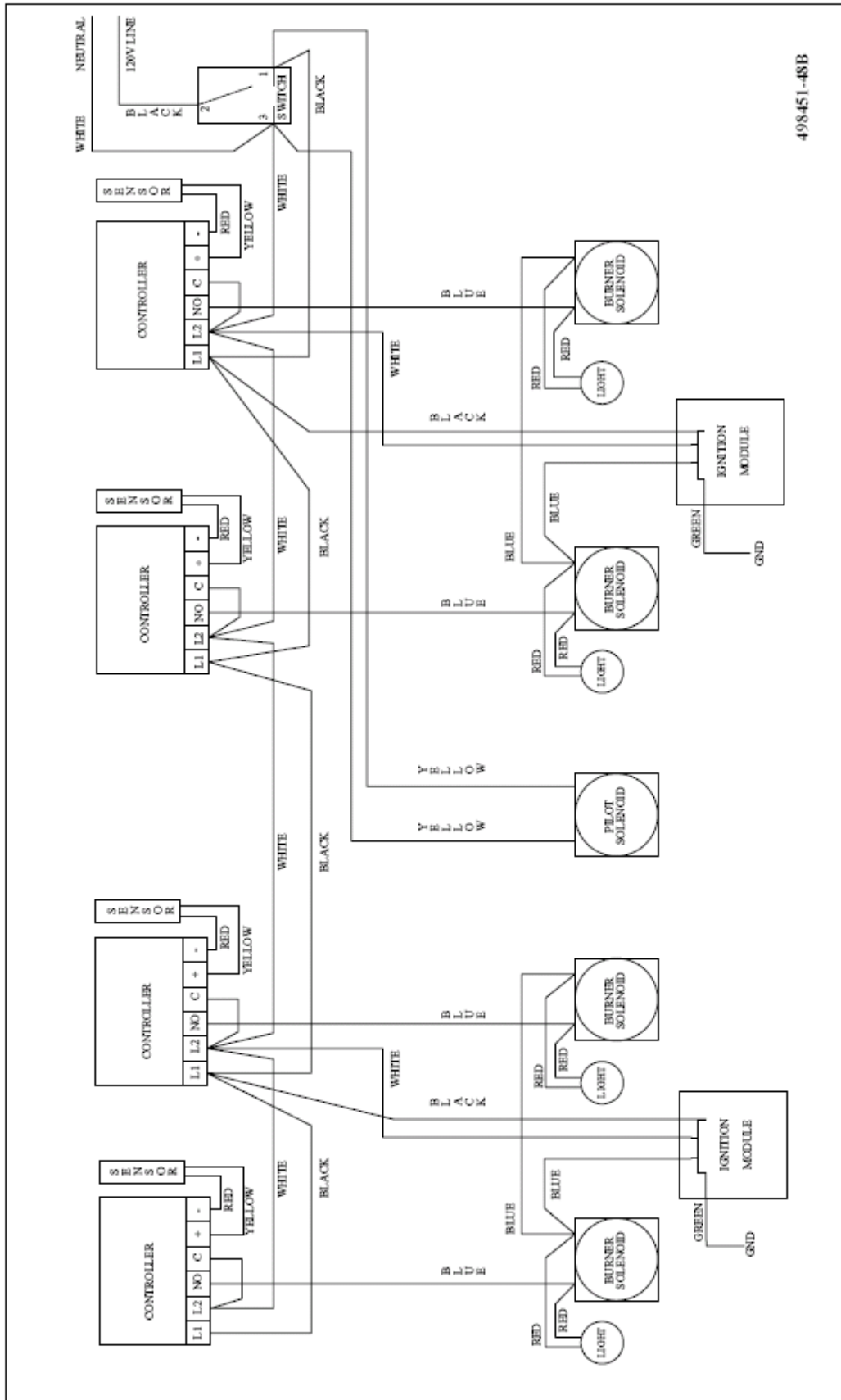

498451-48B

WIRING DIAGRAM – 60-INCH GRIDDLE

