



Assembly Guide



E3600iNetTV
COMMERCIAL FITNESS BIKE

Assembly Guide

E3600iNetTV COMMERCIAL FITNESS BIKE

To avoid possible damage to this Fitness Bike, please follow these assembly steps in the correct order. Before proceeding, find your new Fitness Bike's serial number located on the front axle tube, and enter here:

Refer to this number when calling for service, and enter this serial number on your Warranty Card and in your own records. Be sure to read your Owner's Guide before using your new Fitness Bike. **If any parts, hardware or tools are missing, please call 1.800.335.4348, Extension 12**

NOTE: It is recommended that you apply grease to the threads of each screw as you assemble your Fitness Bike to prevent loosening and noise. Also, during each assembly step, ensure that ALL screws are in place and partially threaded in before completely tightening any ONE screw.

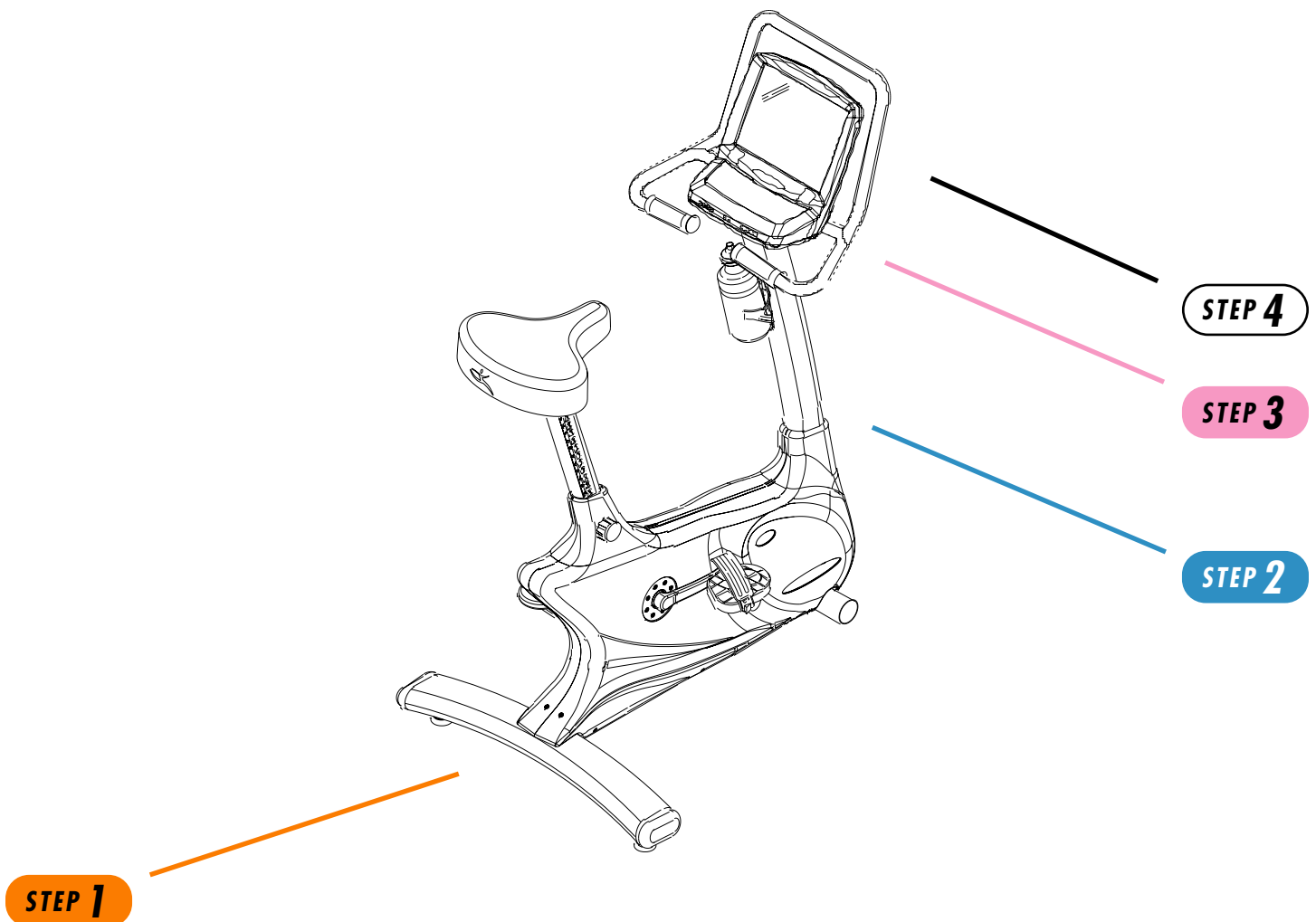

TOOLS & PARTS INCLUDED

5^{mm} Allen Wrench

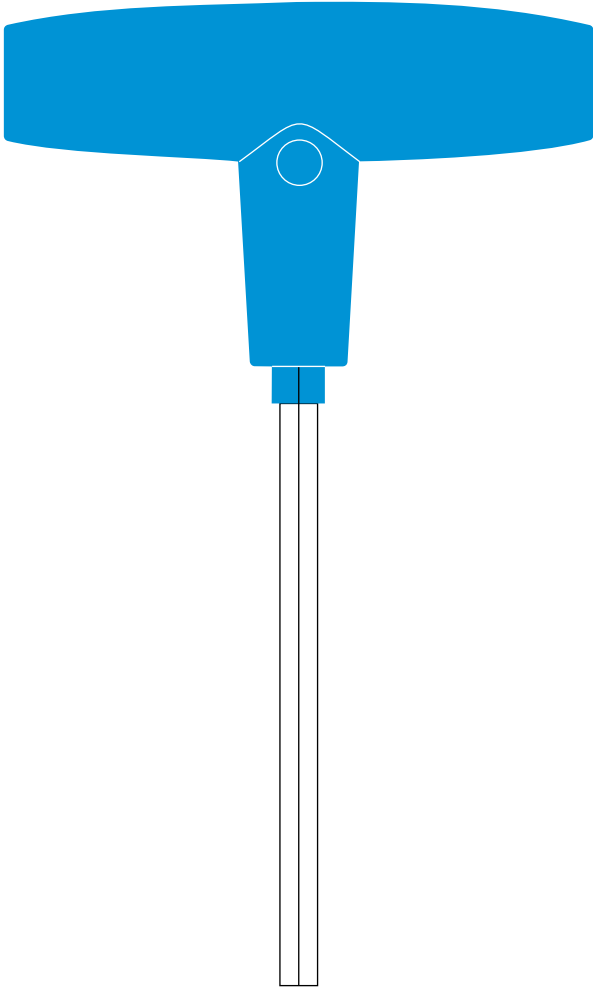

Screwdriver

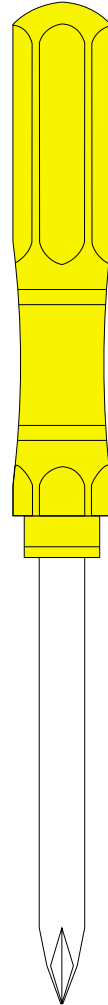

15^{mm} Pedal Wrench

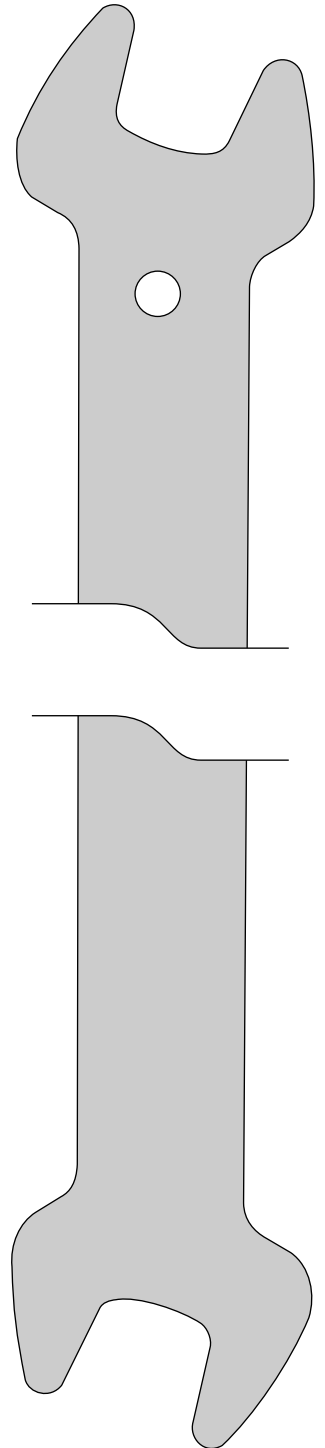

PARTS BOX

Console Mast Cover, Qty: 1
Water Bottle & Cage, Qty: 1
Heart Rate Chest Strap, Qty: 1
Color-coded Hardware Bags
Assembly Guide
Warranty Card

CONSOLE BOX

iNetTV Console
Owner's Guide

HARDWARE INCLUDED

ORANGE BAG

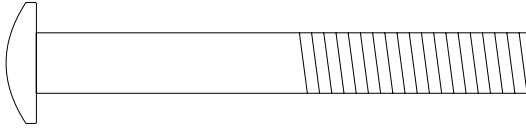
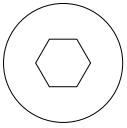

M8 x 65L Screw
Quantity: 2

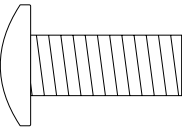
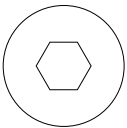

M8 x 20L Screw
Quantity: 2

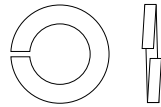

M8 Lock Washer
Quantity: 4

PINK BAG

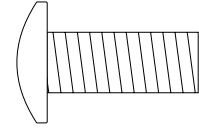
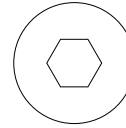

M8 x 20L Screw
Quantity: 2

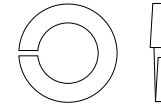

M8 Lock Washer
Quantity: 2

BLUE BAG

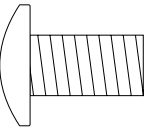
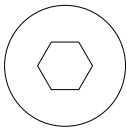

M8 x 15L Screw
Quantity: 7

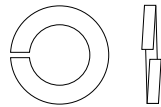

M8 Lock Washer
Quantity: 6

STEP 1

ORANGE BAG

- Install the rear foot with the four lock washers (M8), two inside screws (M8x65L), and two outside screws (M8x20L). Tighten with the 5^{mm} Allen wrench.

STEP 1

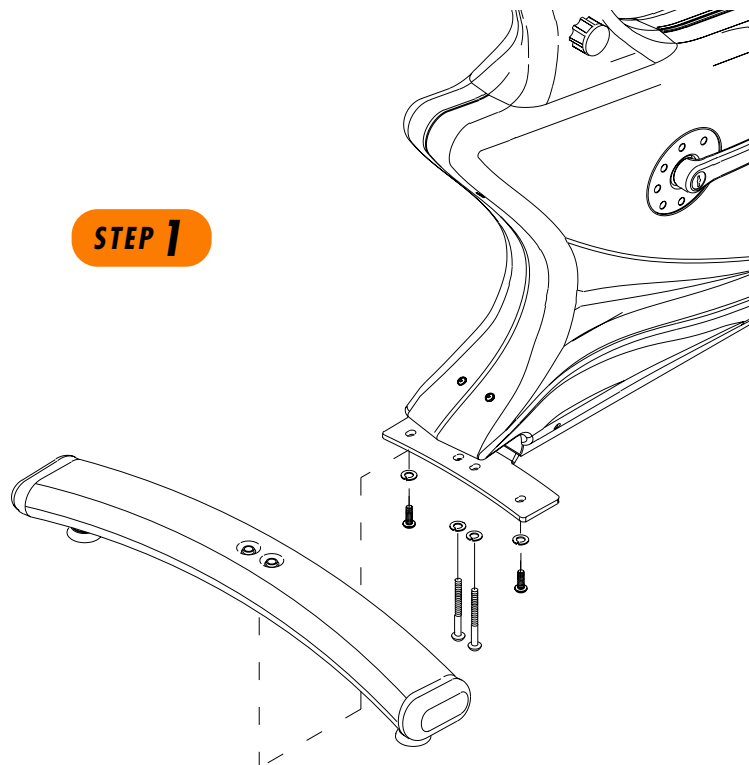

STEP 2

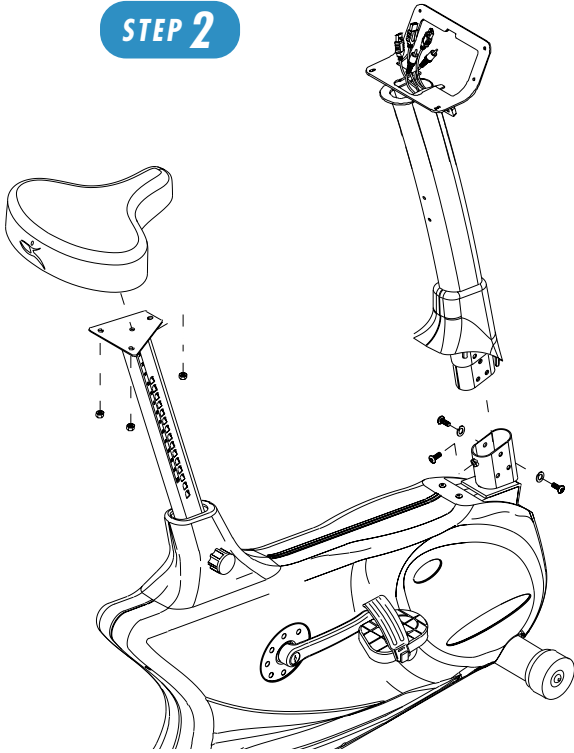

STEP 2

BLUE BAG

- Slide the rubber boot onto the console mast.
- Locate the bundle of wires that comes from the bracket on top of the bike frame. Wrap these wires with the wire tie coming from the bottom of the console mast. Pull the wire tie and bundle of wires up through the top of the console mast while simultaneously sliding the mast into the frame bracket.
- Secure the console mast to the frame bracket with six lock washers (M8) and six screws (M8x15L). Tighten with the 5^{mm} Allen wrench. Place the seventh screw (M8x15L) in the rear of the frame bracket and tighten until snug.
- Slide the console mast boot down and snap it into place on the side cover.
- Remove the nuts (M8) from the screws on the bottom of the seat. Attach the seat to the seat post with the nuts you just removed. Tighten with the 15^{mm} wrench.
- Loosen the seat post knob and slide the seat post into place in the seat tube bracket.

STEP 3

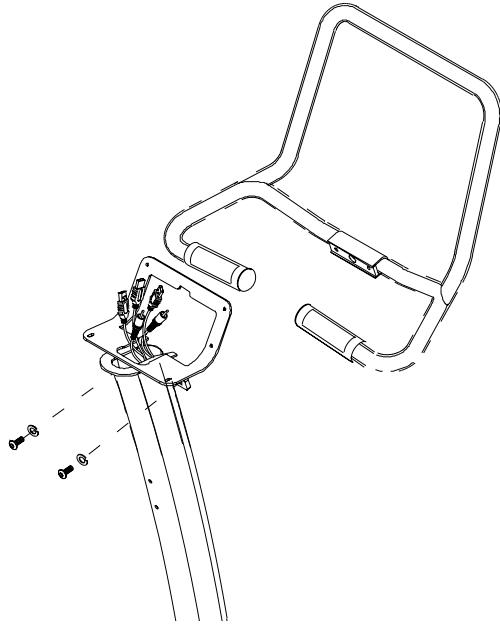

STEP 3

PINK BAG

- Feed the heart rate wires from the handlebars through the small hole located in the front of the console mast. Pull these wires up through the hole at the top of the console mast. Attach the handlebar to the console mast using two lock washers (M8) and two screws (M8x20L). Tighten with the 5^{mm} Allen wrench.

STEP 4**CONSOLE**

- Remove the six mounting screws from the back of the console with the Phillips screwdriver. Set the console in place and secure it to the console mast with the screws you just removed. Connect all the wires to the proper locations in the back of the console (see diagram).

- With the Phillips screwdriver remove the two screws located half way up the console mast. Attach the water bottle bracket to the console mast with the two screws. Insert the water bottle.

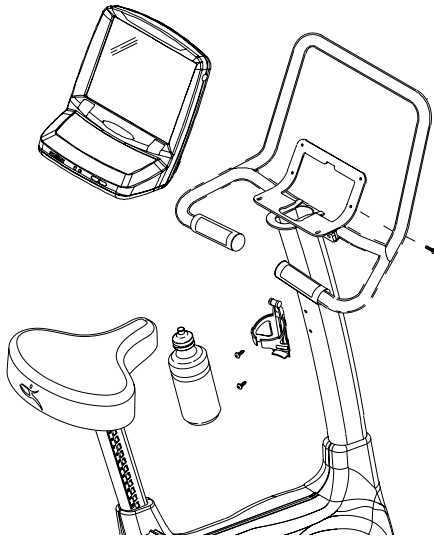
STEP 4

- 1 - Co-Axial Cable TV
- 2 - USB - B
- 3 - USB - A
- 4 - VGA (PC Video)
- 5 - Video IN
- 6 - Audio - R
- 7 - Audio - L
- 8 - Microphone
- 9 - Heart Rate Receiver 1
- 10 - Heart Rate Receiver 2
- 11 - 20 Pin Connector
- 12 - Power Plug
- 13 - Miles/Kilometers Switch
- 14 - Data Port

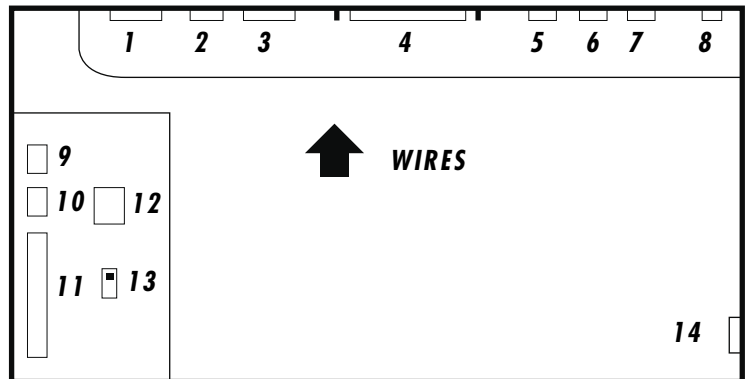

500 South CP Avenue • P.O. Box 280 • Lake Mills, WI 53551
 toll free 1.800.335.4348 • phone 1.920.648.4090 • fax 1.920.648.3373
www.visionfitness.com

©2002 Vision Fitness. All Rights Reserved. 8.02 Part #Z36CB40-AG1824PRD
 AG18.24PRD
 REV1