

# TRANZ 460

---

## FDC Retail/Debit Purchasing Card Reference Manual

Application Version FRET462  
VeriFone Part Number 25445, Revision C  
Manual Revision 1.0

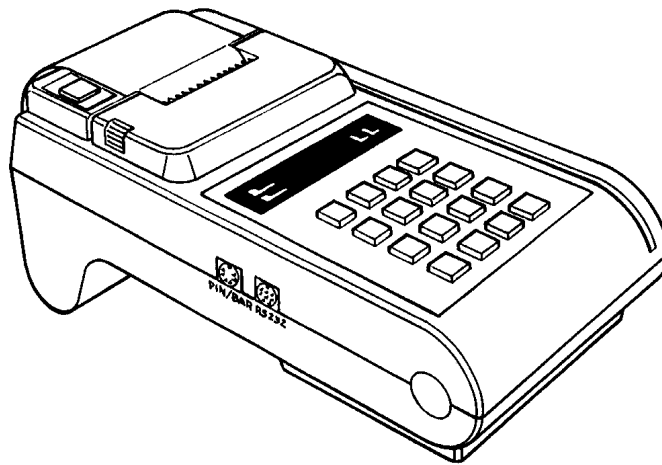

**First Data Corporation**  
**TRANZ 460 Retail/Debit Purchasing Card**  
**Reference Manual**

VeriFone Part Number 25445, Revision C  
Manual Revision 1.0

Published: April 1997  
VeriFone, Inc.  
Three Lagoon Drive  
Redwood City, CA 94065

Printed in the United States of America  
Copyright 1997 VeriFone, Inc.

No part of this manual may be copied, distributed, stored in a retrieval system, translated into any human or computer language, transmitted, in any form or by any means, without the prior written consent of VeriFone, Inc. Publications are not stocked at the address given above. Requests for VeriFone publications should be made to your VeriFone representative.

VeriFone and TRANZ are registered trademarks of VeriFone, Inc. PINpad is a trademark of VeriFone, Inc. All other trademarks or tradenames appearing in this document are the property of their respective owners.

# ***Table of Contents***

---

## **1. Introduction**

Unique Features .....	1-1
Software Version .....	1-1
Integral Printer .....	1-2
PINpad Devices .....	1-2

## **2. Features and Transactions Summary**

New Features .....	2-1
Existing Features .....	2-1
Terminal Transactions Summary .....	2-3
Local or Terminal Functions Summary .....	2-3

## **3. TRANZ 460 Terminal**

Unpacking .....	3-1
Loading/Unloading a Ribbon Cassette in the Printer .....	3-2
Installation .....	3-3
Single Terminal Configuration .....	3-3
Data Connections .....	3-3
DTR/RTS Switch and Power Connections .....	3-4
Telephone Connection .....	3-5
Multi-Lane Configuration .....	3-5
Loading the Printer with Paper .....	3-6
Hardware Features .....	3-7
Display Panel .....	3-7
Cardreader .....	3-7
Keypad .....	3-7
FDC TRANZ 460 Overlay .....	3-8
Maintenance .....	3-8
Cleaning .....	3-8
Returning the TRANZ 460 Terminal for Service .....	3-8
Troubleshooting .....	3-9
Terminal Specifications .....	3-11
Accessories .....	3-11

# ***Table of Contents***

---

## **4. General Programming**

Entering the General Programming Mode .....	4-1
Review a Field .....	4-1
Change a Field .....	4-1
Setting the Calendar/Clock .....	4-2
"Emptying" a Field.....	4-3
Entering Alphanumeric Characters .....	4-3
Copying or Downloading Data to Another Terminal.....	4-4
Fraud Control Programming.....	4-4
Eliminating "PROGRAMING ERROR" .....	4-5
Password Protection .....	4-5

## **5. Programming the Terminal for Use**

Host Information .....	5-1
Account Range Tables.....	5-2
Normal Entries for All Card Types.....	5-3
Security Setup .....	5-4
Update Password .....	5-5
Options Setup.....	5-5
Sale Type Description .....	5-7
Printer/PINpad Device Type.....	5-7
Change Idle Prompt .....	5-8
Clear Batch.....	5-9
Card Type.....	5-9
Memory Map of Important Locations.....	5-9

## **6. Standard Key Operations**

Credit Sale.....	6-1
Debit Sale.....	6-3
Credit Return .....	6-4
Debit Return .....	6-6
Auth Only.....	6-7
Void .....	6-9
Ticket Only .....	6-10

# Table of Contents

---

## 6. Standard Key Operations (cont'd.)

Deposit Inquiry .....	6-11
Close Batch .....	6-12

## 7. Terminal Functions

Item Review .....	7-1
Totals Review .....	7-3
Demo Mode .....	7-4
Print Options .....	7-5

## 8. Accessories

### Appendix A. TRANZ 460 Integral Printer

Paper Detect .....	A-1
Specifications .....	A-1

### Appendix B. PINpad 101 Device

Introduction .....	B-1
PINpad Device Components .....	B-1
Display .....	B-1
Keypad .....	B-2
Selecting a Location for the PINpad Device .....	B-2
Unpacking .....	B-3
Connecting the PINpad Device to the Terminal .....	B-3
Cable Part Numbers .....	B-4
PINpad 101 Device Mounting .....	B-4
Wall Mounting .....	B-4
Countertop Mounting .....	B-5
PINpad Device Startup .....	B-5
The Idle Prompt .....	B-5
Using the Keypad .....	B-5
Maintenance .....	B-6
Cleaning .....	B-6
Returning the PINpad Device .....	B-6
Troubleshooting .....	B-6

# ***Table of Contents***

---

## **Appendix B. PINpad 101 Device (cont'd.)**

Documentation .....	B-7
Part Numbers .....	B-7

## **Appendix C. PINpad 201 Device**

Introduction .....	C-1
PINpad 201 Device Components.....	C-1
Selecting a Location for the PINpad Device.....	C-1
Unpacking.....	C-2
Connecting the PINpad Device to the Terminal .....	C-2
Cable Part Numbers .....	C-3
Cable Routing Channels.....	C-3
PINpad 201 Device Mounting .....	C-3
PINpad Device Startup.....	C-3
The Idle Prompt.....	C-3
Using the Cardreader.....	C-4
Using the Keypad.....	C-4
Maintenance and Keypad Diagnostics.....	C-5
Cleaning.....	C-5
Returning the PINpad Device.....	C-5
Troubleshooting .....	C-5

## **Appendix D. Prompts and Error Messages**

## **Appendix E. ZONTALK Download Parameters**

Data Type Codes .....	E-1
Memory Locations.....	E-2

## **Appendix F. TRANZport 232**

Introduction .....	F-1
Unpacking.....	F-1
Typical Installation .....	F-2
DIP Switch Setting.....	F-3
Testing the TRANZ 460/TRANZport 232 Connection.....	F-4
Specifications .....	F-4

# ***Table of Contents***

---

## **Appendix F. TRANZport 232 (cont'd.)**

Physical.....	F-4
Environmental .....	F-4
Power .....	F-4
Port Configurations.....	F-4
TRANZport 232 Kit .....	F-5
Service .....	F-5

## **Glossary**

## **Index**





# 1. Introduction

---

Congratulations on your choice of the VeriFone® TRANZ® 460 transaction terminal. The TRANZ 460 terminal has many outstanding features that will enable you and your merchants to perform your jobs faster and easier.

Please take the time to read this manual carefully so you become familiar with the equipment and procedures you need to know to perform functions and transactions on your terminal.

## Unique Features

Unique features of the TRANZ 460 are its compact design allowing hand-held operation, and an integral roll printer. The TRANZ 460 terminal operates on an external power supply. This TRANZ 460 application is similar to the FDC TRANZ 380 Retail Debit Purchasing Card application.

## Software Version

The FDC application software package loads only in TRANZ 460 terminals having EPROM version NEAEU200 or higher. To determine the software version your terminal contains, unplug the power cord, then plug it in again. The terminal's display shows the current software version installed. This reference manual is for application version FRET462.

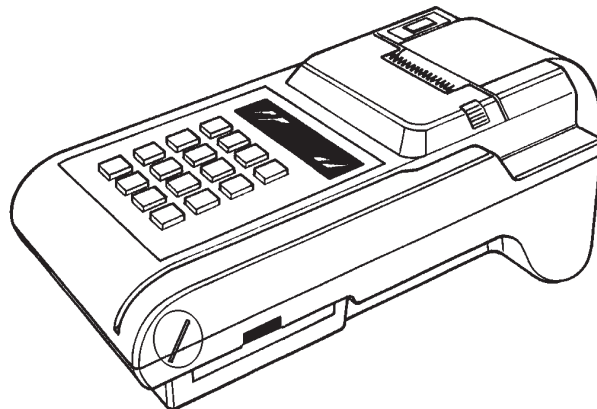

Figure 1-1. The TRANZ 460 Terminal

## Integral Printer

The TRANZ 460 terminal supports an integral roll printer for printing receipts and reports. This application allows you to program a unique merchant header of up to six lines for your receipts. Appendix A provides printer details as well as sample receipts and reports.

## PINpad Devices

The TRANZ 460 terminal supports the PINpad™ 101 and PINpad 201 devices for debit transactions that require customer entry of Personal Identification Numbers (PINs) to verify transaction amounts and totals. Either PINpad device attaches easily to the terminal's side panel. See Appendices B and C for installation instructions and operating procedures.

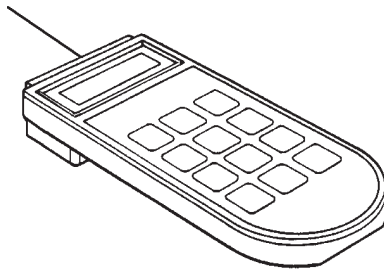

Figure 1-2. PINpad 101 Device

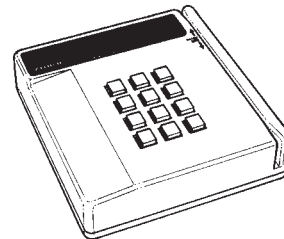

Figure 1-3. PINpad 201 Device

## ***2. Features and Transactions Summary***

---

### ***New Features***

Following is a list of new features that have been added to the FDC Retail/Debit Purchasing Card application.

- ★ The application runs on a TRANZ 460 terminal.
- ★ All receipts and reports are modified to conform to the TRANZ 460 terminal's 24-column format.
- ★ The Virtual Private Line (VPL) communications feature is now enabled through Host setup.

### ***Existing Features***

- The Purchasing Card feature can be enabled by turning on the Customer Code prompt in Account Range setup.
- You can enable Virtual Private Line (VPL) communications (DDOV/ISDN) in the Options setup for faster host response during transactions.
- There are two possible DDOV configurations using a single phone line:
  - One POS terminal and a standard telephone, or
  - Up to 5 POS devices using a multi-lane traffic controller (MTC).
- The terminal features fraud control checks for manual entry and dual track transactions.
- You can enable tax calculation in Options setup and establish a tax rate for calculation purposes.
- An option in Account Range setup enables the Address Verification System (AVS) prompt. If enabled, the AVS code prints on receipts and reports.
- The application supports VISA Payment System (PS) 2000 functionality.
- Two extended prompt fields can be enabled in Options setup for use during Sale, Ticket, or Return transactions.
- Expanded Account Ranges

## FDC Retail/Debit Purchasing Card Reference Manual

---

- You can select Debit functionality in the Setup function.
- Two PINpad devices are available to support Debit functions.
- You can enable split dial for the AMEX and Discover hosts in setup.
- The Auto Close option in Setup enables the terminal to automatically perform the Close transaction and print reports.
- The setup option Sale Type Description is available, enabling the terminal to prompt the operator to enter the description of a Sale transaction.
- Current settings are displayed at each setup prompt.
- While reviewing a transaction, the Item Review function allows you to Void, Edit, and print each transaction.
- You can print terminal totals by card type and detail reports by item number.
- All captured transactions are numbered for buffer review.
- The idle prompt includes the total number of spaces left for transaction storage in the current batch.
- The prompt for entry of the card account number indicates the item number for that transaction.
- You can customize up to 6 merchant header lines for receipts and reports, as well as 6 flexible customer agreement lines and 3 flexible message lines.
- The abbreviated record display, as well as the full buffer review, includes code letters indicating transaction type: S = Sale, R = Return, VS = Void Sale, VR = Void Return, etc.
- Card ranging includes the option for the Retail Terms prompt.
- The application performs expiration date checking for expired cards.
- A setup option allows you to customize the idle prompt.
- Demo Mode simulates the communications process and host response.

## 2. Features and Transactions Summary

---

<b>Terminal Transactions Summary</b>	<b>Key No.</b>	<b>Key Name</b>	<b>Explanation</b>
	1	SALE	Obtains credit card sale authorization and Ticket
	2	RETURN	Authorizes a return/credit
	3	AUTH ONLY	Authorizes a transaction without ticket capture
	4	VOID	voids any host-captured transaction
	5	TKT ONLY	Processes Offline Ticket transactions
	6	INQUIRY	Checks previous business day's deposits
	8		Not used
	9	CLOSE	Closes the terminal batch

<b>Local or Terminal Functions Summary</b>	<b>Key Sequence</b>	<b>Explanation</b>
	BLUE KEY + 1	Item Review of captured tickets
	BLUE KEY + 2	Terminal Totals
	BLUE KEY + 3	Demo Mode
	BLUE KEY + 4 + (code)	Setup functions: Code 1 = Host Setup Code 2 = Account Range Setup Code 3 = Security Setup Code 4 = Change Password Code 5 = Terminal Options Setup Code 6 = Sale Type Description Code 7 = Printer/PINpad Device Type Code 8 = Change Idle Prompt Code 9 = Clear Batch Code 0 = Card Type Label
	BLUE KEY + 5	Print (item, totals and reprint)
	BLUE KEY + 6	Display Current Time



## 3. **TRANZ 460 Terminal**

---

The TRANZ 460 terminal is an authorization and electronic transaction terminal that performs Point-Of-Sale (POS) credit and debit authorizations. It features the convenience of an integral roll printer for printing transaction receipts and reports.

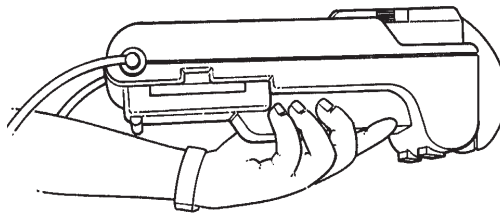

Figure 3-1. TRANZ 460 Terminal

### **Unpacking**

Carefully inspect the shipping carton and its contents for shipping damage. If the TRANZ 460 is damaged, file a claim immediately with the shipping company or carrier and notify VeriFone. Do not use a damaged terminal.

1. Remove all of the items from the carton. You should have:
  - TRANZ 460 terminal
  - Power pack
  - Telephone line cord
  - Roll of carbon paper (for ribbonless operation), or printer ribbon cassette and paper roll
  - TRANZ 460 Installation Guide
2. Remove any protective plastic wrapping from the terminal and place all the components on a table or counter top.
3. Remove the plastic strip from the display panel. This strip protects the plastic panel during shipment.
4. Save the carton and packing material for repacking or moving the terminal in the future.

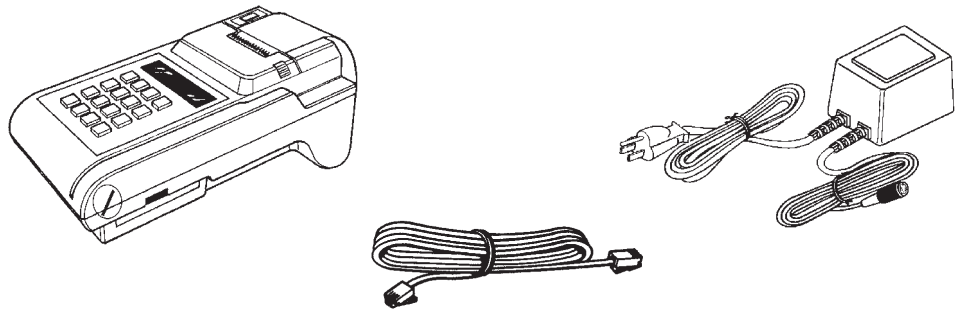

Figure 3-2. TRANZ 460 Components

*Note: If your TRANZ 460 terminal operates ribbonless, disregard the following steps.*

### **Loading/Unloading a Ribbon Cassette in the Printer**

If a ribbon cassette is not already loaded in the printer, or if a new cassette is required, perform the following steps:

1. Press in on the two finger grooves on either side of the print mechanism cover, lift up and remove the cover (see Figure 3-3).
2. Press in on the two finger grooves on either side of the paper roll cover and pull back to remove.
3. Push down on the right side of the ribbon cassette (labeled PUSH) and remove the cassette (see Figure 3-4, Step 1).



Figure 3-3. Removing the Printer Cover

4. Insert the new ribbon cassette (Figure 3-4, Step 2) and gently push the cassette down without locking the rotation of the ribbon feed roller.
5. Turn the cassette "knob" (marked by an arrow; Figure 3-4, Step 3) clockwise to stretch the ribbon .

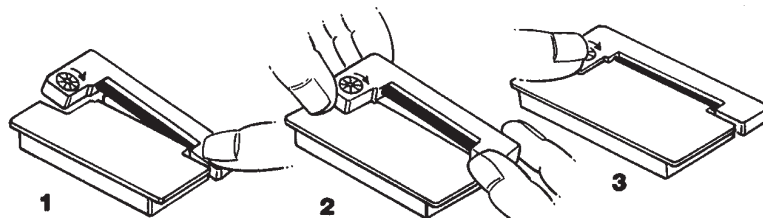

Figure 3-4. Loading and Unloading the Ribbon Cassette



## Installation

This application can operate in either of two configurations, both using a single telephone line. One configuration consists of a TRANZ 460 terminal and a standard telephone sharing the same telephone line. The other configuration supports up to five terminals per phone line, using a multi-lane traffic controller.

### Single Terminal Configuration

In a single terminal configuration, there are two RS-232 devices: a Data-Over-Voice Multiplexer (DVM) and a printer. The TRANZ 460 terminal can connect to a TRANZport 232 device, which enables it to communicate with the DVM and printer, or both terminal and printer can connect directly to the DVM, provided the printer port on that device is compatible with VeriFone equipment.

Follow these steps to connect your TRANZ 460 terminal to the printer and to the DVM device. Refer also to Appendix F, *TRANZport 232*, for more complete details of the various serial interface and power cables available to install your DDOV TRANZ 460 terminal. Figures 3-5 through 3-7 illustrate connections to a TRANZport 232 device.

*Note: In the following configuration the TRANZ 460 receives its power from the TRANZport 232. The power pack that came with your TRANZ 460 should be used with the TRANZport 232.*

### Data Connections

1. Using one of the supplied serial interface cables (PN 00446-04), plug the DIN-8 end into the TRANZ 460 serial port. Plug the DB-9 end of this cable into the connector labeled **TERMINAL** on the TRANZport 232. (See Figure 3-5.)
2. Plug the DIN-8 end of the second supplied serial interface cable into the connector labeled **B** on the TRANZport 232. The DB-9 end of this cable should be plugged into the DVM (Figure 3-6).

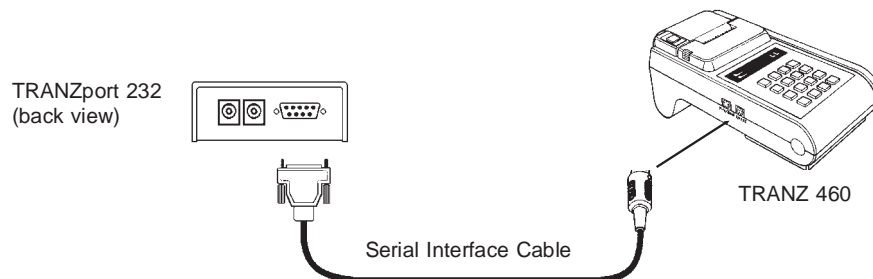

Figure 3-5. Serial Interface Cable Connection

*Note: If connection is via DVM only, the terminal's RS-232 cable plugs into the DVM's RS-232 connector. The DVM also features a 25-pin connector for the serial port connection.*

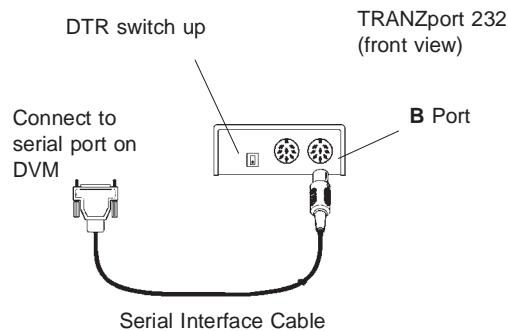

Figure 3-6. TRANZport 232 Data Connections

## DTR/RTS Switch and Power Connections

1. Set the DTR/RTS switch on the TRANZport 232 to the UP position.
2. Plug one end of the power pass-thru cable into the Power In connector on the TRANZ 460. Plug the other end of this cable into the connector labeled **POWER OUT** on the TRANZport 232. Plug the TRANZ 460 power pack into the connector labeled **POWER IN** on the TRANZport 232.
3. Plug the power pack into an indoor, 120 volt AC outlet.

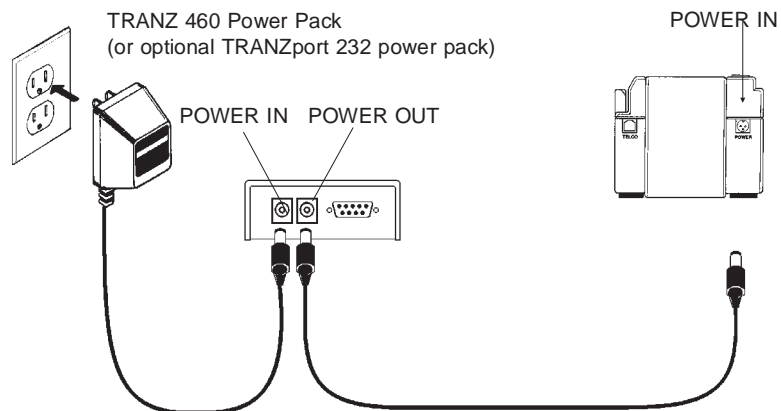

Figure 3-7. TRANZ 460/TRANZport 232 Power Connections

4. Remove the paper roll cover as shown in Figure 3-8 to expose the on/off switch on the inside back panel. Turn the battery on by sliding the switch to the right "on" position.
5. Once the battery is turned "on" and the terminal is connected to the power pack, notice that the POWER indicator at the top, left-hand corner of the terminal comes on, either "blinking" on and off (indicating that the battery is recharging) or "steady" (indicating that the battery is already fully charged).
6. Upon receiving power the terminal displays "FRET462" to identify the software application. *Note: The application is loaded only if it came from your bank or Independent Service Organization (ISO). If you received a terminal directly from VeriFone, contact your bank or ISO for application download information.*

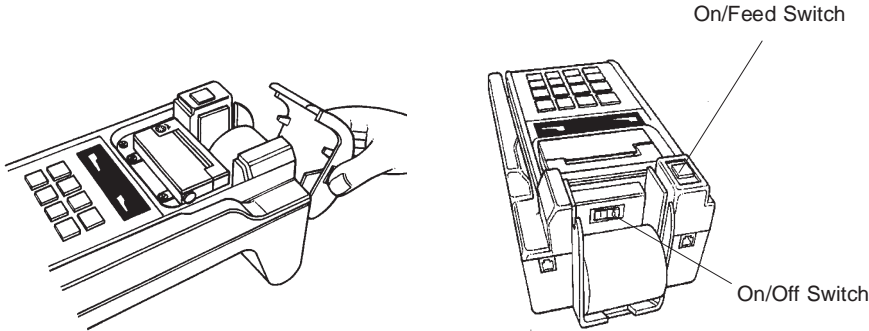

Figure 3-8. TRANZ 460 Battery Switch

Note: Because the power on/off switch is the only way the terminal can be completely powered down, set it to "off" and then "on" again any time you wish to reset the terminal (for example, during the software development stage).

**Telephone Connection**

1. Connect one end of the telephone line cord to the modular jack on the rear of the terminal (see Figure 3-9).
2. Connect the other end of the line cord to a modular telephone wall jack. If you do not have a modular wall jack, obtain an adapter from your local telephone company.

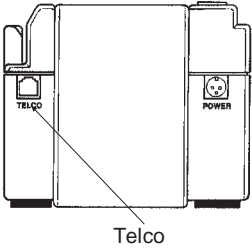

Figure 3-9. Telephone Connection

**Multi-Lane Configuration**

In a multi-lane configuration, a Multi-lane Traffic Controller (MTC) device supports up to five POS terminals and connects to an RJ11 dialup port. Terminals that support printers use a smart "Y" cable to connect to the MTC. The MTC device connects to the DVM (single entry multiplexer), which then sends data to the host over a single telephone line via a PAD (packet assembler-disassembler) at the telephone company using T3POS protocol for rapid host response. Figure 3-10 is a block diagram showing a multi-lane environment connection layout.

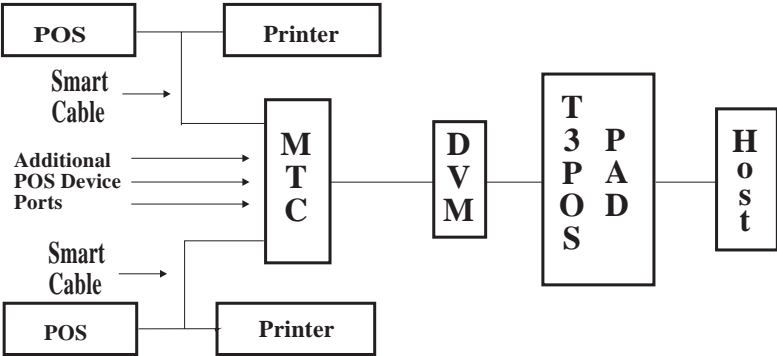

Figure 3-10. Multi-Lane Configuration Block Diagram

*Note: In a single terminal configuration, the printer and terminal connect separately to the DVM, each using its own cable. In a multi-lane configuration, the printer and terminal connect to the MTC via one "Smart" Y cable.*

### Loading the Printer with Paper

*Caution: Because impact, friction, temperature, humidity, light, and oil affect the coloring and storage characteristics of no-carbon-required paper, handle this type of paper carefully. Never load a roll of paper that has any folds, wrinkles, tears, or holes at edges or in the printing area.*

1. Remove both printer mechanism cover and paper roll cover.
2. Unroll several inches of paper. With the cut edges of the paper pointing up, insert the paper spindle through the paper roll and place the roll into the slots on the inside of the terminal.
3. Slide the edges of the paper over the second paper spindle and insert them into the slot at back of printer, making sure that the left edge of the paper is at the left edge of the slot and that the roll is aligned properly (upper and lower paper edges match).
4. Press the On/Feed key located at the top of the terminal to feed the paper through the printer (see top right, Figure 3-11).
5. Replace the paper roll cover.
6. Replace the printer mechanism cover on the terminal, making sure the paper is free to feed through the opening on the top of the cover.

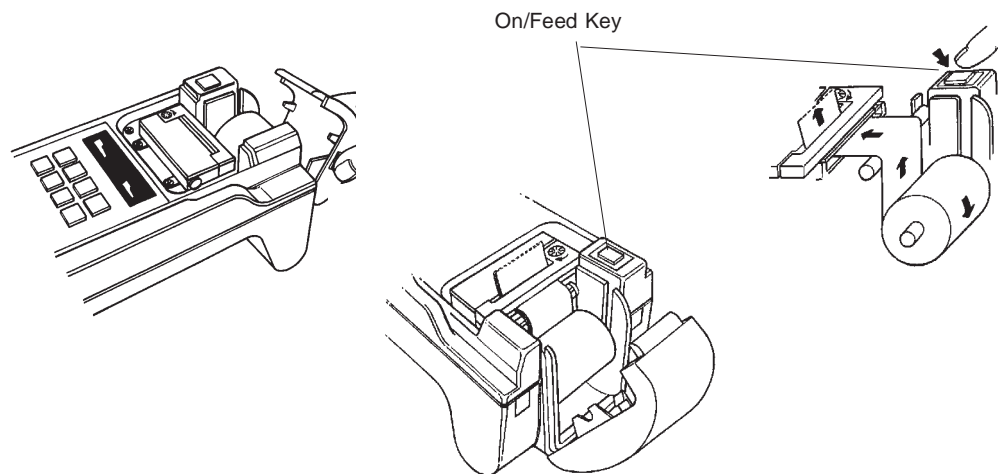

Figure 3-11. Loading the Printer with Paper

## Hardware Features

**Display Panel** The 16-character alphanumeric display panel provides the visual prompts and information needed to operate the TRANZ 460. This bright blue, vacuum fluorescent display is easy to read, even under poor lighting conditions. It displays fully-formed numerals, letters and punctuation symbols.



Figure 3-12. TRANZ 460 Display Panel

**Cardreader** The TRANZ 460 features an ISO Track 2 or optional Track 1 cardreader (slot on the right-hand side) for reading the magnetic stripe data on most major credit, private and debit cards. Customer identification information can be entered simply by sliding the credit or debit card through the slot.

Place the card at the back of the cardreader slot with the magnetic stripe down and to the right, as illustrated in Figure 3-13. Slide the card towards you without stopping.

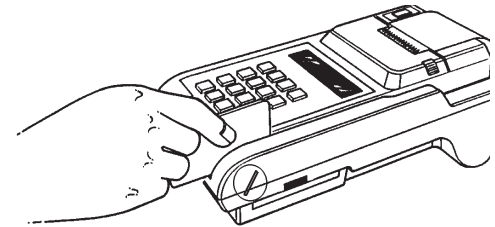
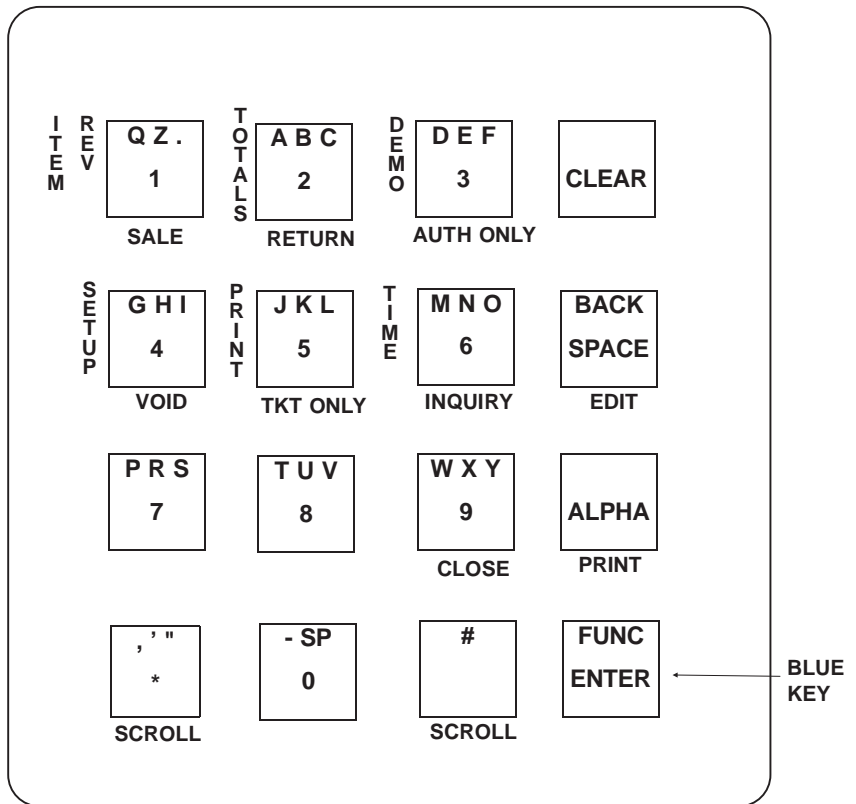

Figure 3-13. Cardreader

The cardreader reads the card data for validation by the terminal's application.

**Keypad** The keypad has 16 keys for entering alphabetical and numeric data. The functions of the keys are as shown on the following page.

H O S T	QZ. 1	ABC 2	DEF 3	CLEAR
	GHI 4	JKL 5	MNO 6	BACK SPACE
	PRS 7	TUV 8	WXY 9	ALPHA
K E Y S	, ' " *	- SP 0	#	FUNC ENTER



## FDC TRANZ 460 Overlay

The keypad overlay for the FDC ETC PLUS Retail Debit application is VeriFone Part Number 10730-37. Please contact your VeriFone representative for ordering information.

## Maintenance

### Cleaning

Periodically clean your TRANZ 460 terminal using a cloth dampened with water and a mild soap or cleaner. Do not use harsh chemicals.

*Warning: Because your terminal can be damaged by liquids, do not spray liquid cleaners directly on the terminal. Always apply the cleaner to the cloth before cleaning the terminal.*

### Returning the TRANZ 460 Terminal for Service

For replacement or repair of your TRANZ 460 terminal, call the toll free number given below. Be sure to mention the serial number found on the bottom of your terminal.

- If you are located in the United States, call 800-834-9133.
- If you are located outside the United States, call 714-979-1870.

- Unless otherwise instructed in this reference manual, do not, under any circumstances, attempt any service, adjustments, or repairs on this unit.
- If your equipment failure cannot be resolved, call the toll free (800-834-9133) VeriFone Customer Support Hot Line and ask for an MRA (Merchandise Return Authorization) approval number. You must have an MRA approval number before returning your equipment for repair.

## Troubleshooting

These troubleshooting guidelines identify various problems and the appropriate corrective action. If you have problems operating your TRANZ 460 terminal, read these troubleshooting examples. If your problem persists, or if it is not listed here, call the VeriFone Customer Support Hot Line listed above.

### **Error Messages**

Appendix D of this manual lists the different prompts and error messages that may appear on the display panel. If you see any of these messages, refer to this appendix for an explanation of the message.

### **Display Panel Does Not Display Correct Information**

If the TRANZ 460 displays incorrect information, such as an unreadable message or nothing at all, you may have a power problem or a defective terminal. Follow these steps to determine the cause of the problem:

1. Your application may not have been properly loaded; repeat the downloading procedure again.
2. Run the Display Test, as described in Section 4, *Diagnostics*, of the TRANZ 460 Reference Manual, to ensure the display components are working.
3. If the problem persists, call the toll free VeriFone Customer Support Hot Line to have your terminal repaired or replaced.

### **Telephone Does Not Work Properly**

1. Check your telephone line and telephone connections.
2. Check the phone lines using another standard telephone. If the other telephone works, have your telephone repaired or replaced.

### **Printer Does Not Work**

1. Verify that there is a ribbon cassette properly loaded in the printer, (or disregard this step if your terminal operates ribbonless).
2. Verify that the printer paper is properly loaded in the printer. The printer will not operate without a paper roll correctly installed.
3. Check the terminal for signs of power failure.

4. Press the CLEAR key and try the operation again; an improper command may have been used.

### **Terminal Transactions Do Not Work**

1. Perform your transactions using several credit cards to ensure the problem is not a defective card. When sliding the cards through the cardreader, be sure the magnetic stripe faces down and to the right of the terminal.
2. Your application may not be properly loaded.
3. Perform a manual transaction using the keypad instead of the cardreader. If the transaction works, call the toll free VeriFone Customer Support Hot Line to have your terminal repaired or replaced.

### **Keypad Does Not Respond**

1. Check your display panel. If it displays the wrong characters or nothing at all, refer to the first item in this troubleshooting section, "Display Panel Does Not Display Correct Information."
2. Press several keys. If Memory Location 0009 contains a "0," you should hear a short beep each time you press a key. If key beep works, make sure you are entering the correct data.
3. Run the Keypad Test described in Section 4 of the TRANZ 460 Reference Manual to ensure the keypad components are working properly.
4. If Memory Location 0009 contains a "0" or is <empty> and you do not hear a beep, or if the keys do not operate as the applicaton says they should, contact the MRA desk.



## Terminal Specifications

Microprocessor: Z80A CPU operating at 3.579 MHz  
 Memory: 32 Kbyte EPROM and 32 Kbyte RAM  
 Cardreader: ISO 7811 Track 2 or Track 1 compatible  
 Display: 16-character fluorescent, alphanumeric, 14-segment with decimal point and comma  
 Communication: Automatic dialing  
 Auto answer: Terminal dials whether touch tone or pulse (rotary mode) and accepts 32-digit telephone numbers  
 Automatically dials host computer and call center numbers  
 Modem: Internal modem with modular jack  
     Model 103, 300 baud (Bell 103 type) modem  
     Model 212A Standard Bell 212A high-speed dial-up modem, 1200/300 baud

<b>Operating Environment</b>	0° to 40°C, 32° to 104°F
	Humidity: 20% to 80%; no condensation
<b>Dimensions and Weight</b>	Voltage: 95 to 130 VAC, 60 Hz (USA Model) 194 to 260 VAC, 50 Hz (International Model)
	Height: 4.57 in. (116 mm)
	Width: 5.83 in. (148 mm) Depth: 11.85 in. (301 mm) Shipping Weight: Approximately 4 lb

## Accessories

	<b>Part Number</b>	<b>Description</b>
<b>Direct Download Cable</b>	00764-XX	TRANZ 460 to IBM PC or compatible personal computer
	00765-XX	TRANZ 460 to IBM AT or compatible personal computer
	10600-XX	TRANZ 460 to TRANZ 460
	10602-XX	Adapter, mini 8 DIN (used with pn 10600-XX)
<b>Peripheral Devices</b>	00302-03	Bar Code Wand
	10601-XX	Adapter, mini 6 DIN
	P003-106-02	PINpad 101 Device
	01582-00	Cable, TRANZ 460 to PINpad 101 device
	10601-XX	Adapter, mini 6 DIN
	P003-120-05	PINpad 201 Device
01582-00	Cable, TRANZ 460 to PINpad 201 device	

## FDC Retail/Debit Purchasing Card Reference Manual

---

<b>Programming Languages</b>	P006-205-00	TCL Programming Package
	00368-01	TCL Programmer's Manual (manual only)
	10016	TCLOAD Manual and diskette
<b>Reference Manuals</b>	10768-01	ZONTALK 2000 Reference Manual
	10664	TRANZ 420 Programmer's Manual
	12412	TRANZ 460 Reference Manual

## 4. General Programming

---

The TRANZ 460 terminal allows you to:

- Review a field
- Move to another field
- Change it if necessary
- Display your new programmed data

### Entering the General Programming Mode

---

To enter the general programming mode, press BLUE + 7. The terminal displays:

RECALL WHAT?

#### Review a Field

To review the contents of a specific field, enter the memory location you wish to review, then press [ENTER]. For example, if you entered 0100, you would see a message similar to the following:

0100 = 18002289074

To review the contents of another specific field, enter the memory location number, then press [ENTER].

To quickly move to adjacent fields, press [ENTER] to go to the next field (or keep pressing the key to move through several fields) or press [ALPHA] to go back to the previous field.

#### Change a Field

To program or change a field, press BLUE + 7.

<b>Display</b>	<b>Response</b>
RECALL WHAT?	0100
0100=18002289074	Press [BACKSPACE]
ENTER PASSWORD*	Key in "1[ALPHA] [ALPHA] 66831", press [ENTER]*.
0100=	Key in new data, press [ENTER].

\* Once you enter the password, the terminal will remain unlocked and not require a password entry until you press both the [CLEAR] and a function key or you remove the power cord from the terminal.

*Note: FDC TRANZ software has been designed with ten unique Setup codes: BLUE + 4 + Codes 0 through 9. You should always use the Setup functions to enter data in the various fields. Use this alternate programming procedure only for entering data in other unique fields such as Fraud Control.*

### Setting the Calendar/Clock

You can set the calendar/clock after unpacking your new TRANZ 460 terminal. The calendar/clock will not copy when you perform a terminal-to-terminal application copy.

To set the clock, simultaneously press the [\*] and [3] keys. Release both keys. The display shows:

<b>Display</b>	<b>Response</b>
DIAGNOSTICS	Press the [ALPHA] key.
RTC CHIP TEST	Respond to each prompt that follows.
YEAR 1980-2079 =	Enter a 2-digit number (94, 95, etc.), then press [ENTER].
MONTH =	Enter a number (1–12) representing the month, then press [ENTER]. January = 1 February = 2 March = 3, etc.
DAY =	Enter the day of the month, then press [ENTER]. You can enter "2" or "02" for February 2nd.
HOUR 0-23 =	Enter a number, 0 through 23, to identify the hour of the day in 24-hour format, then press [ENTER]. Enter "10" for 10 A.M. or "16" for 4 P.M.
MINUTES =	Enter the number of minutes, from 0 to 59, currently past the hour, then press [ENTER]. For example, enter "14" if the time is 10:14.
SECONDS =	Enter the number of seconds, from 0 to 59, currently past the minute, then press [ENTER]. For example, enter "23" if the time is 10:14 and 23 seconds.
(day of week, date and time)	The terminal displays the new date and time.

*Note: If you press the [CLEAR] key at any time before you complete this function, the terminal does not accept any of the data you entered and will default to a "zero out" date and time.*

### "Emptying" a Field

You can easily delete data previously entered in a memory location in the TRANZ terminal.

1. Press [CLEAR], [BLUE] and [7].
2. Key in the field you wish to delete. The terminal displays the contents already stored in that field.
3. Press [BACKSPACE].
4. Key in "1 [ALPHA] [ALPHA] 66831" and press [ENTER].
5. Press [ENTER] again.
6. The terminal displays that field again as <EMPTY>.

### Entering Alphanumeric Characters

Twelve of the terminal's sixteen keys can be used to enter alphanumeric characters. These characters are the letters A through Z, the numerals 0 through 9, and the following special characters: \* , ' " - . # : : @ and [space].

Press the key containing the desired character, then press [ALPHA] as many times as required to display the correct character.

*Note: The terminal must be in a mode that allows data entry, such as the STORE or RECALL modes, before information can be entered from the keypad. Transaction codes which require entry of alpha characters are an exception to this rule.*

The following examples demonstrate how the characters 2, A, B, and C are entered using the [2] key and the [ALPHA] key.

<b>Desired Character</b>	<b>Keys to Press</b>
2	Press the [2] key
A	Press the [2] key Press the [ALPHA] key once
B	Press the [2] key Press the [ALPHA] key twice.
C	Press the [2] key. Press the [ALPHA] key three times.

## ***Copying or Downloading Data to Another Terminal***

---

Downloading is the process of copying data from one computer or terminal to another. VeriFone supports direct downloading which lets you quickly copy an application from one terminal to another, using the proper download cable.

*Note: The TRANZ download cable, P/N 00490-00, will copy both TRANZ and XL terminals.*

Follow these steps to perform a terminal-to-terminal download.

1. Plug both terminals into a 120 VAC power outlet.
2. Connect the download cable to the round 8-pin connector on the backs of both terminals. This is the same connector used for the printer.
3. Press [BLUE] + [\*] on the sending terminal (the one which contains the application to be transferred to the other terminal). The terminal displays:

UNIT SEND

4. Press [BLUE] + [#] on the receiving terminal. The terminal displays:

UNIT RECEIVE

*Note: Steps 3 and 4 can be done in either order.*

5. If the transfer is OK, the terminals display "UNIT SENDING" and "UNIT RECEIVING."

*Note: If the displays do not change to UNIT SENDING and UNIT RECEIVING, you may be using an XL only download cable.*

6. Wait approximately 23 seconds and DO NOT TOUCH ANY KEY.
7. When copying is completed, both displays read "SUCCESSFUL."

## ***Fraud Control Programming***

---

You can help control credit card fraud at the merchant location several ways using a TRANZ 460 terminal.

- Require the clerk to key in the last four digits of the embossed card number after sliding the card through the cardreader. The terminal compares data read off the card's magnetic stripe with data entered on the keypad.
- Check the contents of the card's magnetic stripe on the terminal display after sliding it through the card reader.
- Program your terminal for both features.

Program Field 0X06 (X = key number) for each card you want to have these features enabled.

<b>Field</b>	<b>Entry</b>
0X06 (X = key number)	Enter 0, 1, 2, or 3, then press [ENTER]. 0 = None 1 = Enter last 4 digits 2 = Display Mag Stripe 3 = Options 1 and 2

*Note: For this application, Fraud Control has been eliminated on debit transactions (keys 1 and 2). Locations 0106 and 0206 must be empty for fraud control to NOT occur during a debit transaction. The operating system will attempt to perform Fraud Control if a value is present in 0X06 and a debit transaction is initiated. As a result, 0X06 is cleared when Debit is selected and remains empty until a host key which has the potential for using Fraud Control is pressed. At that time, 0X06 is updated from a value stored during the copyright display after initial download (the value of 0106 is stored in 0635 and the value of 0206 is stored in 0636).*

## ***Eliminating "PROGRAMING ERROR"***

---

If your terminal displays a "PROGRAMING ERROR" message, you have two options to attempt recovery:

1. Press the [3] and [5] keys simultaneously. The TRANZ 460 recalculates the check sum digit that may be the cause of the "PROGRAMMING ERROR." A new download of the application is not necessary.
2. Simultaneously press the [1] and BLUE keys until the calendar/clock reappears on the display. A new download of the application is required. Follow the procedures for downloading from one terminal to another on page 4-3 or call the VeriFone Customer Support Help Desk for a telephone download.

## ***Password Protection***

---

The FDC TRANZ 460 application allows you to password-protect most of the transactions and functions. This can be accomplished via a ZONTALK download, the Setup function, or by entering the appropriate string of 12 characters in Memory Location 0859.

The character positions in the string and corresponding transactions are as follows:

## FDC Retail/Debit Purchasing Card Reference Manual

---

Character Position	Transaction
1	Sale
2	Return
3	Auth Only
4	Void
5	Ticket
6	Deposit Inquiry
7	Close Batch
8	Item Review
9	Totals Review
10	Setup
11	Print
12	Demo

To set the password option for a particular transaction, enter a "1" in the corresponding position. If you do not wish to password-protect a particular transaction, enter a "0" in the corresponding position.

For example, to turn on password protection for Sale and Void transactions, enter the string in Memory Location 0859 like this:

0859=100100000000



## 5. Programming the Terminal for Use

---

Check Memory Location 0019 to ensure your terminal is loaded with the correct software version before you begin programming. Press BLUE + 7, then enter 0019. The terminal should display " 0019 = FRET462." If Memory Location 0019 contains data other than this, please contact your VeriFone representative.

To prepare your terminal for use, you must enter the Setup function key sequence (BLUE + 4) and Codes 1 through 0 for the selected Setup.

1 = Host Setup	6 = Sale Type Description
2 = Account Range Tables	7 = Printer Type/PINpad Device Setup
3 = Security Setup	8 = Change Idle Prompt
4 = Password Setup	9 = Clear Batch
5 = Terminal Options	0 = Card Type Label

### Host Information

Use this function to store the FDC host telephone numbers and merchant IDs. The merchant ID should be programmed without a prefix. This application displays current data for verification or change. To enter Host Setup:

1. Press BLUE + 4.
2. Key in the manager password.
3. Press the BLUE enter key.
4. Press Code 1.

*Note: You may press the [ENTER] key to bypass any field and not disturb what has already been programmed. If something is already programmed and you wish to make a change, you must first press [BACKSPACE], then key in the new data.*

Display	Response
HOST INFO	FDC Host primary and secondary phone numbers and merchant ID number. If you need to dial "9" first, then pause, enter "9-XXXXXXX". Each "-" causes a 2-second delay in dialing.
FDR PRIMARY #?	
FDR SECOND #?	
FDR CLOSE PHONE?	
FDR MERCH ID?	

If this is an FDC "public port" number, add "LØ" or "XØ" at the end of the telephone number. For example, if the local "public port" number is 123-4567, you must key in "1234567LØ" or "1234567XØ."

## FDC Retail/Debit Purchasing Card Reference Manual

---

Display	Response
AMEX SPLIT Y/N AMEX PRIMARY #? AMEX SECOND #? AMEX MERCH ID? AMEX CARD TYPE?	Enter "Y" to enable split dial for the AMEX host, and continue with remaining prompts. Enter "N" to disable split dial and go to the Discover prompts.  <i>Note: MERCH ID and CARD TYPE prompts will not appear if there is an open batch.</i>
DISC SPLIT Y/N DISC PRIMARY #? DISC SECOND #? DISC MERCH ID? DISC CARD TYPE?	Enter "Y" to enable split dial for the Discover host, and continue with remaining prompts. Enter "N" to disable split dial and go to the "ENABLE VPL" prompt.  <i>Note: MERCH ID and CARD TYPE prompts will not appear if there is an open batch.</i>
ENABLE VPL? Y/N <current value>	Enter "Y" to enable Virtual Private Line (VPL) communications, or "N" for standard dialup communications.
DOV=1 ISDN=2	Enter "1" for the DOV address, or "2" for the ISDN address.
BANKCARD ADDRESS 99999999999999999999	Press [ENTER] to accept the current address, or key in the host address up to 20 numeric characters, then press [ENTER].

## Account Range Tables

Use this function to program the card types your terminal will accept. To enter the Account Range Setup:

1. Press BLUE + 4.
2. Key in the manager password.
3. Press the BLUE enter key.
4. Press Code 2.

*Note: You may scroll past fields you wish to leave unchanged unless the terminal prevents you, in which case you must enter a value. You can change/modify one item in a card account range provided you scroll past all remaining prompts in the card range.*

Display	Response
CARD RANGE INFO ACCT RANGE ITEM?	Enter a digit 1–20. The number you enter here determines the field between 0043 and 0062 in which the card range will be stored. If you enter "1", the entire account range will be stored in field 0043.

## 5. Programming the Terminal for Use

---

Display	Response
nn-LOW?	Enter the first six digits of the low range of the credit card account number, then press [ENTER]. For example, the low account number range for VISA is 400000.
nn-HIGH?	Enter the first six digits of the high range of the credit card account number, then press [ENTER]. For example, the high account number range for VISA is 499999.
nn-CARD TYPE ?	Enter the card type, 1–6, then press [ENTER]. For example: 1 = VISA or MasterCard 2 = American Express or Diner's Club 3 = Discover, etc.  <i>Note: The application uses this information to generate reports by card type.</i>
nn-CARD ABBREV?	Enter the card abbreviation, press [ENTER]. (VIS = VISA, MC = MasterCard, etc.)
nn-TERMS? Y/N	Press [9] for Y to enable Retail Terms prompting, or [6] for N to disable.
nn-DESC CODE 0/2/4	Select "0" for no Descriptor Code prompting, or "2" or "4" to allow 2- or 4-digit Descriptor Codes.
nn-AVS? Y/N	Press [9] for Y to enable AVS prompts, or [6] for N to turn them off.
nn-CUST CODE? Y/N	Press [9] for Y to enable the prompt for a customer code, or [6] for N to turn it off.

### Normal Entries for All Card Types

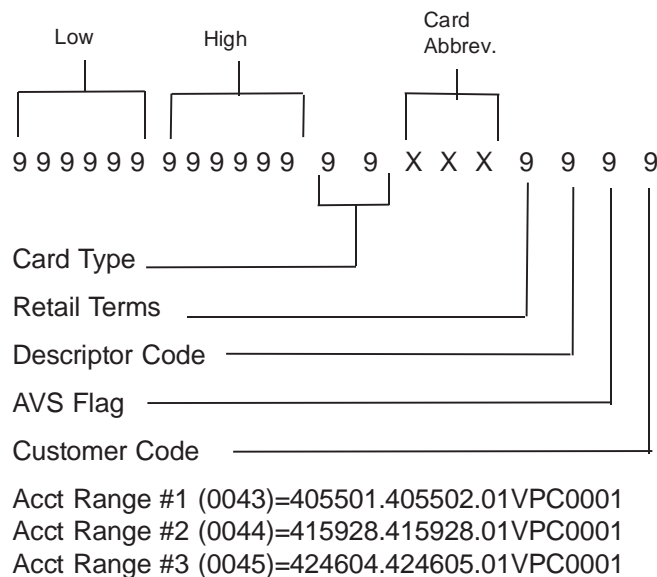

Acct Range #4 (0046)=427533.427533.01VPC0001  
Acct Range #5 (0047)=428800.428800.01VPC0001  
Acct Range #6 (0048)=443085.443085.01VPC0001  
Acct Range #7 (0049)=471500.471699.01VPC0001  
Acct Range #8 (0050)=400000.499999.01VIS0000  
Acct Range #9 (0051)=540500.540599.02MPC0001  
Acct Range #10 (0052)=500000.599999.02MC 0000  
Acct Range #11 (0053)=340000.349999.03AMX0000  
Acct Range #12 (0054)=370000.379999.03AMX0000  
Acct Range #13 (0055)=300000.389999.04DC 0000  
Acct Range #14 (0056)=601100.601199.05DIS0000  
Acct Range #15 (0057)=000000.099999.06FDR0000  
Acct Range #16-#20 (0058-0062)=<empty>

*Note: The "." after the low and high fields is required to make the account ranging work properly.*

## Security Setup

Use this function to set password protection for each individual terminal transaction or function. To enter the Security Setup:

1. Press BLUE + 4.
2. Key in the manager password.
3. Press the BLUE enter key.
4. Press Code 3.

<b>Display</b>	<b>Response</b>
SECURITY	
SET SALE? Y/N	Enter [Y] to set password protection for a transaction, or [N] if you do not wish to password protect the transaction. Press keys [9] and [6] for "Y" and "N" responses.
SET RETURN? Y/N	
SET AUTH? Y/N	
SET VOID? Y/N	
SET TICKET? Y/N	To access protected functions, the operator must enter the manager password.
SET DEP INQ? Y/N	
SET CLOSE? Y/N	
SET ITM REV? Y/N	
SET TOT REV? Y/N	
SET SETUP? Y/N	
SET PRINT? Y/N	
SET DEMO? Y/N	

### Update Password

Use this function to update the manager password. To enter the "Update Password" Setup:

1. Press BLUE + 4.
2. Key in the manager password.
3. Press the BLUE enter key.
4. Press Code 4.

<b>Display</b>	<b>Response</b>
UPDATE PASSWD ENTER NEW PASSWD VERIFY NEW PASSW	Enter the new manager password. Enter the password a second time to verify. If both entries match, the terminal displays "PASSWORD UPDATED."

### Options Setup

Use this function to set terminal options. To enter the Options Setup:

1. Press BLUE + 4.
2. Key in the manager password.
3. Press the BLUE enter key.
4. Press Code 5.

<b>Display</b>	<b>Response</b>
OPTIONS DEVICE ID?	Press [BACKSPACE], enter a 4-character operator ID if there is one, then press [ENTER]. Press [ENTER] to bypass this prompt or press [BACKSPACE] then [ENTER] to leave this field blank.
INVOICE #? Y/N	Select "Y" if you wish to be prompted for entry of the invoice number, or "N" for no prompting.
OPERATOR ID? Y/N	Select "Y" if you wish the terminal to prompt for entry of an operator ID, or "N" for no prompting.
PHONE ORDER? Y/N	Select "Y" if you wish to be prompted for Phone Orders, or "N" for no prompt.
RECEIPT? Y/N	Select "Y" if you wish the printer to automatically print receipts for all transactions, or "N" for no receipt printing.

## FDC Retail/Debit Purchasing Card Reference Manual

---

Display	Response
PREPRINT? Y/N	Select "Y" if you wish the receipt header to print before the terminal dials, or "N" for no preprinting.
AUTO REPORT? Y/N	Select "Y" if you wish the printer to automatically print Detail and Terminal Totals reports at Batch Close, or "N" for no report printing.
AUTO INSERT? Y/N	Select "Y" if you wish the terminal to automatically insert batch totals at Batch Close, or "N" for no totals insertion.
PREDIAL? Y/N	Select "Y" for the terminal to begin dialing the host prior to transaction completion, or "N" for no pre-dialing.
MAN ENTRY? Y/N	Select "Y" to enable manual as well as card swipe account data entry, or "N" for card swipe entry only.
TAX PROMPT? Y/N	Select "Y" to enable a tax prompt.  <i>Note: In this application, you MUST turn on the tax feature if using Purchasing Card functionality.</i>
TAX CALC? Y/N	Select "Y" for the terminal to automatically calculate the tax on the amount, or "N" to disable this option.
TAX RATE 99.99	If you select "Y" for TAX CALC, key in the tax rate, then press [ENTER].
OPTION FIELD Y/N	Select "Y" to enable extended prompt fields, or "N" for no extended prompts.
PROMPT FIELD #1	Key in the first extended prompt, up to 16 characters, then press [ENTER].
PROMPT FIELD #2	Key in the second extended prompt, up to 16 characters, then press [ENTER]
AUTO CLOSE Y/N CLOSE TIME HH:MM	Select "Y" and key in the close time in 24-hour format for Auto Close, or "N" for no Auto close.

### Sale Type Description

Use this function to select the transaction type. To enter the Sale Type Setup:

1. Press BLUE + 4.
2. Key in the manager password.
3. Press the BLUE enter key.
4. Press Code 6.

<b>Display</b>	<b>Response</b>
SALE TYPE DESC <current value>	Press [ENTER] to leave unchanged, or key in up to 7 alphanumeric characters and press [ENTER] to change the name of the transaction type for all Sale transactions.

### Printer/PINpad Device Type

Use this function to enable/disable the printer and identify the type of PINpad device you will be using. To enter the Printer/PINpad device setup:

1. Press BLUE + 4.
2. Key in the manager password.
3. Press the BLUE enter key.
4. Press Code 7.

<b>Display</b>	<b>Response</b>
PRINTER / PINPAD PRINTER? Y/N	This prompt appears if there is anything stored in Memory Location 0950. Press [6] for "N" to remove the printer and return to the "ENTER SETUP CODE" prompt or press [9] for "Y" to continue.
MERCHANT LOGO LINE 1?   LINE 6?	Enter the merchant name and address using up to 24 characters per line and up to 6 lines of information. If data is already present, press [BACKSPACE], enter the information, and press [ENTER], or [BACKSPACE] and [ENTER] to leave the field empty. If no data is present, key in data and press [ENTER].
FLEX AGREEMENT LINE 1?   LINE 6?	Enter up to 6 flexible agreement lines using up to 24 characters per line. If data is already present, press [BACKSPACE], enter the agreement information, then press [ENTER].

<b>Display</b>	<b>Response</b>
FLEX AGREEMENT (cont'd.)	Press [BACKSPACE] and [ENTER] to leave this field empty. If no data is present, key in data and press [ENTER].
FLEX MESSAGE LINE 1? LINE 2? LINE 3?	Enter up to 3 flexible message lines, using up to 24 characters per line. If data is already present, press [BACKSPACE], enter the message line, then press [ENTER], or press [BACKSPACE] and [ENTER] to leave this field empty. If no data is present, key in data and press [ENTER].
DEBIT? Y/N	Select "Y" to enable Debit functionality, or "N" to disable.
1=PP101, 2=PP201	Select "1" for PINpad 101 device, or "2" for PINpad 201 device support for Debit transactions.

### Change Idle Prompt

Use this function to program your terminal to display a custom prompt. To enter the Change Idle Prompt Setup:

1. Press BLUE + 4.
2. Key in the manager password.
3. Press the BLUE enter key.
4. Press Code 8.

<b>Display</b>	<b>Response</b>
IDLE PROMPT	Press [BACKSPACE] and enter up to 16 alphanumeric characters, then press [ENTER], or press [BACKSPACE], then [ENTER] to use the default idle prompt "READY **nnn**."



### Clear Batch

Use this function to clear all transactions from an open batch. To enter the Clear Batch Setup:

1. Press BLUE + 4.
2. Key in the manager password.
3. Press the BLUE enter key.
4. Press Code 9.

<b>Display</b>	<b>Response</b>
CLEAR BATCH CLEAR? Y/N	Enter [9] for "Y" to continue, or [6] for "N" to return to the ENTER SETUP CODE prompt.
ENTER TO CONFIRM	Press the [ENTER] key. The terminal clears the batch and returns to the setup code prompt.

### Card Type

Use this function to enter the card type labels. To enter the Card Type Setup:

1. Press BLUE + 4.
2. Key in the manager password.
3. Press the BLUE enter key.
4. Press Code 0.

<b>Display</b>	<b>Response</b>
CARD NAME ENTER CARD TYPE	Enter a number, 1–10, to select the Card Type to name.
<card name>	The terminal displays the current value of the card type. Enter a different card type, up to eight characters, then press [ENTER].

### **Memory Map of Important Locations**

You can review your programming of the TRANZ 460 terminal by pressing BLUE + 7, then keying in the desired field. See Section 4, *General Programming*, for procedures to follow if you wish to review or change selected fields. Refer to Appendix E, *ZONTALK 2000 Download Parameters*, for specific download information pertaining to this application.



## 6. Standard Key Operations

---

Retail transactions are common, unprotected transactions that all personnel can perform. These transactions include Sale, Return, Debit Sale and Return, Void, Ticket Only, Inquiry, and Close Batch.

The TRANZ 460 idle prompt, "nnn" indicates spaces left for storage of transactions. For example, READY \*\*3\*\* indicates there is space to store three more transactions in the current batch. When the file is full, the idle prompt displays "BATCH FULL" and no further transaction can be stored until you close the batch and clear the file from the terminal.

*Note: Displays that appear during terminal communications with the host may differ depending upon the selected protocol and logon.*

### Credit Sale

Follow these procedures to capture a credit sale transaction that requires host authorization.

Display	Response
1. READY **nnn** SALE	Press the [1] key labeled SALE.
2. ENTER PASSWORD *****	Enter the manager password if required, then press [ENTER]. The display echoes each keypress with an asterisk.
3. CREDIT=0 DEBIT=1	Press "0" for a credit transaction.
4. itm ENTER ACCT #	Enter the account number via the keypad or slide the card through the cardreader, then press [ENTER]. If entry is made via the cardreader, continue with Step 6.
	<i>Note: "itm" is the item number for this transaction.</i>
5. EXPIRY DATE MMY	Enter the 4-digit expiration date using 2 digits each for month and year, then press [ENTER].
PROCESSING ...	

## FDC Retail/Debit Purchasing Card Reference Manual

---

*Note: Prompts in Step 6 and Steps 8 through 17 may or may not appear, depending upon options selected in Setup.*

---

<b>Display</b>	<b>Response</b>
6. OPERATOR ID	Enter the 4-digit operator ID, then press [ENTER], or press [ENTER] to bypass this prompt.
7. AMOUNT OF SALE ?	Enter the amount of the sale without the decimal, then press [ENTER].
8. TAX AMOUNT	Enter the tax amount without the decimal, then press [ENTER]. If TAX CALC is enabled, the terminal automatically calculates the tax based on the tax rate. If both are enabled, the TAX AMOUNT overrides tax calculation.
9. RETAIL TERMS	Enter the retail terms, up to 4 digits, then press [ENTER].
10. PHONE ORDER? Y/N	Enter [9] for "Y" if this is a phone order, or [6] for "N" if it is not, then press [ENTER]. Press [ENTER] to bypass if no Phone Order.
11. DESC CODE	Enter the descriptor codes, up to 4 sets, then press [ENTER].
12. ENTER INVOICE #	Enter the invoice # up to 8 digits, then press [ENTER].
13. CUSTOMER CODE	Enter the customer code, if required, then press [ENTER].
14. AVS ADDRESS	Enter the cardholder's street number, then press [ENTER].
15. AVS ZIP CODE	Enter the cardholder's ZIP code, 5–9 numeric digits, then press [ENTER].
16. <option prompt #1>	Enter appropriate data, up to 8 alphanumeric characters, then press [ENTER].
17. <option prompt #2>	Enter appropriate data, up to eight alphanumeric characters, then press [ENTER].
18. PROCESSING or <communication prompts>	The terminal is communicating with the host via VPL lines. If these lines fail, dialup lines are used and the terminal displays the standard communication prompts.
19. <host message>	The terminal displays the host response. Record the approval number. If the transaction is disapproved, take necessary action. Press [CLEAR] to return to the idle prompt.

## 6. Standard Key Operations

---

Display	Response
PRINTING...	If the transaction is approved and the printer is enabled, the printer prints a receipt of the transaction.
20. READY **nnn**	The terminal returns to the idle prompt indicating it is ready for the next transaction.

**Debit Sale** Follow these procedures to capture a debit sale transaction.

Display	PINpad Device	Response
1. READY **nnn** SALE		Press the [1] key labeled SALE.
2. ENTER PASSWORD  *****		Enter the manager password if required, then press [ENTER]. The display echoes each keypress with an asterisk.
3. CREDIT=0 DEBIT=1  OUT OF PAPER		Press "1" for a debit transaction.  Press [CLEAR] to return to the idle prompt.
4. AMOUNT OF SALE ?		Enter the amount of the sale without the decimal, then press [ENTER].
5. TAX AMOUNT		Enter the tax amount without a decimal, then press [ENTER]. If TAX CALC is enabled, the terminal automatically calculates the tax based on the tax rate. If both are enabled, the TAX AMOUNT overrides tax calculation.
6. SWIPE CARD		If you are using a PINpad 101 device, swipe the customer's debit card through the terminal's cardreader.
7. PROCESSING	<b>SWIPE CARD</b>	If you are using a PINpad 201 device, swipe the debit card through the PINpad unit cardreader.
8. WAITING ON PIN  <b>TOT. \$99999.99</b>		The PINpad device displays the transaction amount.
9. WAITING ON PIN	<b>ENTER PIN PUSH "ENTER"</b>	The customer enters his/her PIN on the PINpad device and presses [ENTER].
10. OPERATOR ID	<b>PROCESSING</b>	Enter the 4-digit operator ID, then press [ENTER], or press [ENTER] to bypass this prompt.

## FDC Retail/Debit Purchasing Card Reference Manual

---

Display	PINpad Device	Response
11. ENTER INVOICE #		Enter the invoice number up to 8 digits, then press [ENTER].
12. <option prompt #1>		Enter appropriate data, up to 8 alphanumeric characters, then press [ENTER].
13. <option prompt #2>		Enter appropriate data, up to eight alphanumeric characters, then press [ENTER].
14. PROCESSING or <communication prompts>	<b>PROCESSING</b>	The terminal is communicating with the host via VPL lines. If these lines fail, dialup lines are used and the terminal displays the standard communication prompts.
15. <host message>	<b>THANK YOU</b>	The terminal displays the host response. Record the approval number. If the transaction is disapproved, you should take necessary action. Press [CLEAR] to return to the idle prompt. If the transaction is approved and the printer is enabled, the printer prints a receipt of the transaction.
16. READY **nnn**		The terminal returns to the idle prompt indicating it is ready for the next transaction.

### Credit Return

Follow these procedures to authorize a credit card return. This transaction is always performed offline.

Display	Response
1. READY **nnn** RETURN	Press the [2] key. The terminal pauses and displays the type of transaction.
2. ENTER PASSWORD  *****	Enter the manager password if required, then press [ENTER]. The display echoes each keypress with an asterisk.
3. CREDIT=0 DEBIT=1	Press "0" for a credit return.
4. itm ENTER ACCT #	Enter the account number via the keypad or slide the card through the cardreader, then press [ENTER]. If entry is made via the cardreader, continue with Step 5.

## 6. Standard Key Operations

---

Display	Response
5. EXPIRY DATE MMY	Enter the 4-digit expiration date using 2 digits each for month and year, then press [ENTER].
PROCESSING ...	
<i>Note: Prompts in Step 6 and Steps 8 through 15 may or may not appear, depending on options selected in Setup.</i>	
6. OPERATOR ID	Enter the 4-digit operator ID, then press [ENTER], or press [ENTER] to bypass this prompt.
7. AMOUNT OF SALE ?	Enter the amount of the sale without the decimal, then press [ENTER].
8. TAX AMOUNT	Enter the tax amount without a decimal, then press [ENTER]. If TAX CALC is enabled, the terminal automatically calculates the tax based on the tax rate. If both are enabled, the TAX AMOUNT overrides tax calculation.
9. RETAIL TERMS	Enter the 4-digit retail terms, then press [ENTER].
10. PHONE ORDER? Y/N	Enter [9] for "Y" if this is a phone order, or [6] for "N" if it is not, then press [ENTER]. Press [ENTER] only if no Phone Order.
11. DESC CODE	Enter the descriptor codes, up to 4 sets, then press [ENTER].
12. ENTER INVOICE #	Enter the invoice number up to 8 digits, then press [ENTER].
13. CUSTOMER CODE	Enter the customer code, then press [ENTER].
14. <option prompt #1>	Enter appropriate data, up to 8 alphanumeric characters, then press [ENTER].
15. <option prompt #2>	Enter appropriate data, up to 8 alphanumeric characters, then press [ENTER].
PROCESSING ...	
16. ACCEPTED itm (itm=trans. item #)	Record the approval number. Press [CLEAR] to return to the idle prompt.
17. READY **nnn**	The terminal returns to the idle prompt indicating it is ready for the next transaction.

## ***Debit Return***

---

Follow these procedures to capture a debit return transaction. This transaction will always be performed online.

<b>Display</b>	<b>PINpad Device</b>	<b>Response</b>
1. READY **nnn** SALE		Press the [2] key labeled RETURN.
2. ENTER PASSWORD  *****		Enter the manager password if required, then press [ENTER]. The display echoes each keypress with an asterisk.
3. CREDIT=0 DEBIT=1  OUT OF PAPER		Press "1" for a debit transaction.  Press [CLEAR] to return to the idle prompt.
4. AMOUNT OF SALE ?		Enter the amount of the sale without the decimal, then press [ENTER].
5. TAX AMOUNT		Enter the tax amount without a decimal, then press [ENTER]. If TAX CALC is enabled, the terminal automatically calculates the tax based on the tax rate. If both are enabled, the TAX AMOUNT overrides tax calculation.
6. SWIPE CARD		If you are using a PINpad 101 device, swipe the customer's debit card through the terminal's cardreader.
7. PROCESSING	<b>SWIPE CARD</b>	If you are using a PINpad 201 device, swipe the debit card through the PINpad unit cardreader.
8. WAITING ON PIN	<b>TOT. \$99999.99</b>	The PINpad device displays the transaction amount.
9. WAITING ON PIN	<b>ENTER PIN PUSH "ENTER"</b>	The customer enters his/her PIN on the PINpad device and presses [ENTER].
10. OPERATOR ID	<b>PROCESSING</b>	Enter the 4-digit operator ID, then press [ENTER], or press [ENTER] to bypass this prompt.
11. ENTER INVOICE #		Enter the invoice number up to 8 digits, then press [ENTER].



## 6. Standard Key Operations

Display	PINpad Device	Response
12. <option prompt #1>		Enter appropriate data, up to 8 alphanumeric characters, then press [ENTER].
13. <option prompt #2>		Enter appropriate data, up to eight alphanumeric characters, then press [ENTER].
14. PROCESSING or <communication prompts>		The terminal is communicating with the host via VPL lines. If these lines fail, dialup lines are used and the terminal displays the standard communication prompts.
	<b>PROCESSING</b>	
15. <host message>	<b>THANK YOU</b>	The terminal displays the host response. Record the approval number. If the transaction is disapproved, you should take necessary action. Press [CLEAR] to return to the idle prompt. If the transaction is approved and the printer is enabled, the printer prints a receipt of the transaction.
16. READY **nnn**		The terminal returns to the idle prompt indicating it is ready for the next transaction.

### Auth Only

This transaction is used to authorize a transaction without ticket data capture.

Display	Response
1. READY **nnn** AUTH ONLY	Press the [3] key labeled AUTH ONLY. The terminal displays the type of transaction.
2. ENTER PASSWORD *****	Enter the manager password if required, then press [ENTER]. The display echoes each keypress with an asterisk.
3. ENTER ACCOUNT #	Enter the account number via the keypad or slide the card through the cardreader. If entry is made via the cardreader, go to Step 5.
4. EXPIRY DATE MMY	Enter the card's expiration date, using two digits each for month and year, then press [ENTER].

## FDC Retail/Debit Purchasing Card Reference Manual

---

Display	Response
PROCESSING ...	
5. AMOUNT OF SALE ?	Enter the amount of the sale without the decimal, then press [ENTER].
6. PHONE ORDER? Y/N	Enter [9] for "Y" if this is a phone order, or [6] for "N" if it is not, then press [ENTER]. Press [ENTER] to bypass for no Phone Order. <i>Note: This prompt may or may not appear, depending on options selected in Setup.</i>
7. AVS ADDRESS	Enter the cardholder's street number, then press [ENTER].
8. AVS ZIP CODE	Enter the cardholder's ZIP code, 5–9 numeric digits, then press [ENTER].
9. PROCESSING or <communication prompts>	The terminal is communicating with the host via VPL lines. If these lines fail, dialup lines are used and the terminal displays the standard communication prompts.
10. <host message>	The terminal displays the host response. Record the approval number. If the transaction is disapproved, you should take necessary action. Press [CLEAR] to return to the idle prompt.
PRINTING...	If the transaction is approved and the printer is enabled, the printer prints a receipt of the transaction.
11. READY **nnn**	The terminal returns to the idle prompt indicating it is ready for the next transaction.

## Void

Follow these procedures to void a transaction completed earlier in the batch. Void transactions are always approved offline.

Display	Response
1. READY **nnn** VOID	Press the [4] key labeled VOID.
2. ENTER PASSWORD  *****	Enter the manager password if required, then press [ENTER]. The display echoes each keypress with an asterisk.
3. ENTER ITEM #  NOT FOUND	Press [ENTER] to display the last transaction or enter the item number of the transaction you wish to void, then press [ENTER].  The terminal cannot find the entered item number. Press [CLEAR] to return to the idle prompt.
4. itm AA \$99999.99 9999999999999999 999 \$99999.99 a \$999.99 OPER I111111 RET TERMS 9999 8888888888888888 AAAAAAAAAAXXXXXX aaaaaaaaaaaaaaaa sssss zzzzz-zzzz <opt #1> <opt #2>	Press [*] or [#] to scroll the display, where: itm = item number AA = transaction type 99999.99 = total amount 999...999 = account number a = AVS response code, \$999.99 = misc. amt OPER = operator ID I111111 = Invoice number RET TERMS 9999 = Retail terms 8888...8888 = Descriptor codes AAA...AAA = Host response aaa...aaa = Transaction Identifier
5. VOID-PRESS ENTER	Press [ENTER] to continue or [CLEAR] to end the transaction.
6. ENTER TO CONFIRM  PROCESSING ...	Press [ENTER] to continue or [CLEAR] to return to the idle prompt.
7. ACCEPTED itm (itm=trans. item #)  PRINTING...	Press [ENTER] to confirm the void, or [CLEAR] to end the transaction.  The transaction was approved offline. If enabled, the printer prints a receipt of the transaction.
8. READY **nnn**	Press [CLEAR] to return to the idle prompt.  The terminal returns to the idle prompt indicating it is ready for the next transaction.

## ***Ticket Only***

---

Follow these steps to process Ticket Only transactions.

*Note: This transaction is always processed offline.*

<b>Display</b>	<b>Response</b>
1. READY **nnn** TKT ONLY	Press the [5] key, labeled TKT ONLY.
2. ENTER PASSWORD  *****	Enter the manager password if required, then press [ENTER]. The display echoes each keypress with an asterisk.
3. itm ENTER ACCT #	Slide the card through the cardreader or enter the account number on the keyboard, then press [ENTER]. If entry is made via the cardreader, go to Step 5.
4. EXPIRY DATE MMY	Enter the 4-digit card expiration date using 2 digits each for the month and year, then press [ENTER].

PROCESSING ...

*Note: Prompts in Step 5 and Steps 7 through 15 may or may not appear, depending upon options selected in Setup.*

5. OPERATOR ID	Enter the 4-digit operator ID number, then press [ENTER].
6. AMOUNT OF SALE ?	Enter the amount of the sale without the decimal, then press [ENTER].
7. TAX AMOUNT	Enter the tax amount without a decimal, then press [ENTER]. If TAX CALC is enabled, the terminal automatically calculates the tax based on the tax rate. If both are enabled, the TAX AMOUNT overrides tax calculation.
8. RETAIL TERMS	Enter the 4-digit retail terms, then press [ENTER].
9. PHONE ORDER? Y/N	Enter [9] for "Y" if this is a phone order, or [6] for "N" if it is not, then press [ENTER]. Press [ENTER] only for no Phone Order.
10. ENTER AUTH CODE	Enter the authorization code, up to 6 alphanumeric characters, then press [ENTER].
11. DESC CODE	Enter the descriptor code, up to 4 sets, then press [ENTER].
12. ENTER INVOICE #	Enter the invoice number up to 8 digits, then press [ENTER].

Display	Response
13. CUSTOMER CODE	Enter the customer code, then press [ENTER].
14. <option prompt #1>	Enter appropriate data, up to 8 alphanumeric characters, then press [ENTER].
15. <option prompt #2>	Enter appropriate data, up to 8 alphanumeric characters, then press [ENTER].
PROCESSING ...	
16. ACCEPTED itm	The terminal displays this response if the transaction was approved. Record the approval number. Press [CLEAR] to return to the idle prompt.
PRINTING...	If the transaction is approved and the printer is enabled, the printer prints a receipt of the transaction.
17. READY **nnn**	The terminal returns to the idle prompt indicating it is ready for the next transaction.

### Deposit Inquiry

Follow these procedures to check the dollar amount of the previous business day's deposits.

Display	Response
1. READY **nnn** INQUIRY	Press the [6] key labeled INQUIRY.
2. ENTER PASSWORD	Enter the manager password if required, then press [ENTER]. The display echoes each keypress with an asterisk.
*****	
3. PROCESSING or <communication prompts>	The terminal is communicating with the host via VPL lines. If these lines fail, dialup lines are used and the terminal displays the standard communication prompts.
4. <host response>	A dollar amount will be displayed on the terminal. Press [*] or [#] to scroll the display. Press [CLEAR] to return to the idle prompt.
5. READY **nnn**	The terminal returns to the idle prompt indicating it is ready to proceed with the next transaction.

## **Close Batch**

Follow this procedure to close a batch of transactions with the host. This will clear the batch from the terminal's memory and enable it to store future transactions.

<b>Display</b>	<b>Response</b>
1. READY **nnn**  CLOSE BATCH	Press the [9] key labeled CLOSE.
2. ENTER PASSWORD  *****  NO TRANSACTIONS	Enter the manager password if required, then press [ENTER]. The display echoes each keypress with an asterisk.  There is no batch.
3. ENTER AMOUNT  PRINTING...	This prompt only appears if the auto-insert totals option is set to OFF. Enter the terminal total amount without the decimal, then press [ENTER].  If the Auto Report option is ON, the printer prints the Detail and Terminal Totals reports.
4. REPORTING? Y/N	Enter [9] for "Y" print the transactions in the batch, or [6] for "N" to continue with the Close.
5. CLOSING >>>> CLOSING >>>>	The terminal is formally closing the batch with the host computer. The display alternates messages indicating it is transmitting and receiving.
6. <host response>	Press [CLEAR] to return to the idle prompt.
7. READY **nnn**	The terminal returns to the idle prompt indicating it is ready to proceed with the next transaction.

# 7. Terminal Functions

---

Terminal functions include operations that do not require communication with a host. To use the terminal in the function mode, press the [FUNC/ENTER] blue key followed by the desired function key.

*Note: The \*\*nnn\*\* indicates the number of spaces left for storage of data capture transactions. For example, READY \*\*3\*\* indicates that there is space for storage of three more transactions.*

## Item Review

---

Use this function to review items stored in the terminal capture file. You may also void a record using the [4] key, print an item and edit an amount field, however, you may not edit a voided record.

<b>Display</b>	<b>Response</b>
1. READY **nnn**	Press [FUNC] and the [1] key labeled ITEM REV.
2. ENTER PASSWORD *****	Enter the manager password if required, then press [ENTER]. The terminal echoes each keypress with an asterisk.
3. ENTER CARD TYPE	Enter [1], [2] ... [10] for card type, then press [ENTER], or press [ENTER] to review the beginning of the batch.  <i>Note: If only one card type was set up for all cards, this prompt does not appear.</i>
4. ENTER ITEM #	Enter the item number of the transaction to review or press [ENTER] to review the first item in the batch.
NOT FOUND	The terminal cannot find the item number. Press [CLEAR] to return to the idle prompt.  <i>Note: This prompt is a warning and may not be displayed. When it is displayed, follow the recommended response.</i>

## FDC Retail/Debit Purchasing Card Reference Manual

---

Display	Response
<p>5. itm AA \$99999.99            999999999999999999            999 \$9999.99            a \$999.99            OPER A IIIIIII            RET TERMS 9999            88888.....8888            AAAAAAAAAAXXXXXX            aaaaaaaaaaaaaa            sssss zzzzz-zzzz            &lt;option data #1&gt;            &lt;option data #2&gt;</p>	<p>Press [*] or [#] to scroll the display fields. The terminal displays transaction data in multiple screens which contain some or all of the following data, depending on setup options:</p> <p>itm = Item number            AA = Transaction type            \$99999.99 = Total amount            999999999999999999 = Account number            999 \$9999.99 = Base sale amount            a \$999.99 = AVS resp. code, tax amount            OPER = Operator ID, if enabled            A = Authorization Character Indicator            IIIIIII = Invoice number            RET TERMS 9999 = Retail terms            888888....88888 = Descriptor codes            AAAAAAAAAAXXXXXX = Host response            aaaa....aaaa = Transaction identifier            sssss zzzzz-zzzz = AVS street address/ZIP</p> <p>Press [ALPHA] to print this record and remain on this step. Press [4] to Void the record and continue with Step 6. If you are viewing an amount field and wish to change the amount, press [BACKSPACE] key in the new amount, press [ENTER] and remain at this step. Press [CLEAR] to end the record review, or press [ENTER] to view the next item.</p>
<p>6. VOID-PRESS ENTER</p>	<p>Press [ENTER] to void this record, or press [CLEAR] to quit.</p>
<p>7. ENTER TO CONFIRM</p>	<p>Press [ENTER] again to confirm the void, or press any other key to return to Step 5. Press [CLEAR] to return to the idle prompt.</p>
<p>END OF BATCH</p>	<p>The terminal displays "END OF BATCH" after review of the last item in the batch. Press [CLEAR] to return to the idle prompt.</p>
<p>8. READY **nnn**</p>	<p>The terminal returns to the idle prompt indicating it is ready to proceed with the next function.</p>



## Totals Review

Follow this procedure to review terminal totals by card type, all card types, or by operator ID.

Display	Response
1. READY **nnn**	Press [FUNC] and the [2] key labeled TOTALS.
2. ENTER PASSWORD *****	Enter the manager password if required, then press [ENTER]. The terminal echoes each keypress with an asterisk.
3. CARD=1 OP=2	Enter "1" for credit card transaction totals and continue with Step 4, or enter "2" for operator totals and continue with Step 7.
4. ENTER CARD TYPE AAAAAAAA	Enter [1], [2] . . . [10], for card type, and press [ENTER], or press [ENTER] to go to Step 6 for the terminal grand total. The card type displays for one second.
5. 99T        999 99999.99 99S        999 99999.99 99R        999 99999.99 99VS       999 99999.99 99VR       999 99999.99	The terminal displays specified totals for the card type. Press [*] or [#] to scroll the display. Press [ENTER] to return to Step 4 or [CLEAR] to end. 99 = card type 01–10 T = Totals, no. items and amount S = Sale totals, no. items and amount R = Return totals, no. items and amount VS = Void Sale totals, no. items, amount VR = Void Return totals, no. items, amount
6. TT    999 999999.99 CDT 999 999999.99 DBT 999 999999.99	The terminal displays grand totals. Press [ENTER] to return to Step 4 and enter another card type to review or press [CLEAR] to return to the idle prompt.
7. OPERATOR ID	Enter the operator ID for individual totals, then press [ENTER] and continue with Step 9, or press [ENTER] for all totals and continue with Step 8.
8. OT            999999.99	The terminal displays totals for all operator IDs (OT= Operator Totals). Press [ENTER] to return to Step 7 and enter another operator ID.
9. O nnn        999999.99	The terminal displays totals for the selected operator ID. Press [ENTER] to return to Step 7 or [CLEAR] to return to the idle prompt.

<b>Display</b>	<b>Response</b>
10. READY **nnn**	The terminal returns to the idle prompt indicating it is ready to proceed with the next function.

## Demo Mode

Follow this procedure to place the terminal in or out of Demo Mode.

<b>Display</b>	<b>Response</b>
1. READY **nnn**	Press [FUNC] and the [3] key labeled DEMO.
2. DEMO Y/N <current value>	Press "Y" for Demo mode, or "N" for Live mode. Press [ENTER] for no change.
3. MUST CLEAR BATCH	There is an open batch. Press [CLEAR] to return to the idle prompt and close the open batch.
4. DEMO **nnn**	The terminal displays the Demo mode idle prompt.

## Print Options

Follow these procedures to print batch details, operator totals, terminal totals or to reprint the last receipt.

Display	Response
1. READY **nnn**	Press [FUNC] and the [5] key labeled PRINT.
2. ENTER PASSWORD  *****	Enter the manager password if required, then press [ENTER]. The terminal echoes each keypress with an asterisk.
3. PRINT OPTION ?	Enter the number that corresponds to the item you wish to print, then press [ENTER].  1 - detail items 2 - terminal totals 3 - reprint last receipt  If you select "1", continue with Step 4. If you select "2", continue with Step 7. If you select "3", continue with Step 8.
4. DETAIL ENTER CARD TYPE	Enter the card type, then press [ENTER] or press [ENTER] for all card types.
5. SORT BY ID? Y/N	Select "Y" to print a detail report by operator number and in item number order, and continue with Step 9. Select "N" for a detail report in item number order only and continue with Step 6.
6. ENTER ITEM #	Enter the item number and press [ENTER], or press [ENTER] for a printed list of all items and continue with Step 9.
7. TOTALS CARD=1 OP=2	Enter "1" for a printed report of credit card transaction totals, then press [ENTER], or enter "2" for a printed report of operator totals. Continue with Step 9.
RE-PRINT	The terminal displays this message for 1 second, then proceeds to reprint the last receipt.
8. ENTER ITEM #	Enter the item number of the record you wish to reprint, or press [ENTER] to reprint the last transaction, provided no new transaction has been initiated.

## FDC Retail/Debit Purchasing Card Reference Manual

---

<b>Display</b>	<b>Response</b>
9. PRINTING...	The printer prints the selected option.
10. READY **nnn**	The terminal returns to the idle prompt and is ready to proceed with the next function.

## 8. TRANZ 460 Accessories

---

VeriFone provides an assortment of accessories to enhance your TRANZ 460 terminals.

- An extended 3-year warranty on all TRANZ 460 terminals
- Silk-screened custom overlays that display your company's logo and other special key functions
- An assortment of AC power packs for your "spares" inventory
- Telephone cords
- Duplex telephone adapters for connecting multiple telephone devices to a single jack
- PINpad devices for entering customer personal identification numbers
- Bar code wands for scanning bar codes
- Consumables such as paper and ribbons you can order by phone (800-233-0522) or FAX (714-434-2498)



Telephone Cord

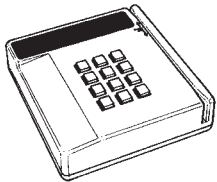

PINpad 201 Device

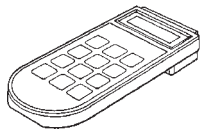

PINpad 101 Device

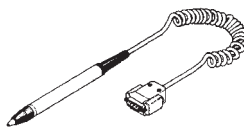

Bar Code Wand

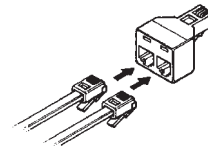

Telephone Adapter



# ***Appendix A. TRANZ 460 Integral Printer***

---

The TRANZ 460 terminal features an integral Epson Model 180 24-character roll printer. Besides the default USA 96-character set, it is capable of supporting a number of special printing enhancements such as TALL, WIDE and INVERSE, eleven different country character sets and a number of useful graphics. Refer to Appendix E of the *TRANZ 460 Reference Manual*, Part Number 12412, for a list and examples of the different character sets as well as printer commands used to control the TRANZ 460 printer.

## ***Paper Detect***

---

There is a paper detection device that prevents printing a transaction without producing a printed receipt. When the paper sensor detects the lack of paper, the printer completes the line it is currently printing, then stops any additional printing.

Refer to Section 3 of this manual for instructions on loading a paper roll and ribbon cassette in the printer.

## ***Specifications***

---

Model: Epson Model M-180 mechanical micro-dot

Printing Method: Impact dot matrix (6 print solenoids)

Print Format: Total dots- 144 max/1 dot line  
Total columns - 24 Max

Copy Capacity: 1 original plus 1 copy

Ribbon Cassette: CRM0012-01, Black  
CRM0012-02, Purple

Paper: CRM0013, woodfree, pressure sensitive

Reliability: MCBF (mean character between failure) 1 million lines

Dimensions: 91 mm wide, 46.9 mm deep, 15.8 mm high

Following is a sample printed receipt for the FDC Sale transaction, and samples of other printed reports.

# FDC Retail/Debit Purchasing Card Reference Manual

---

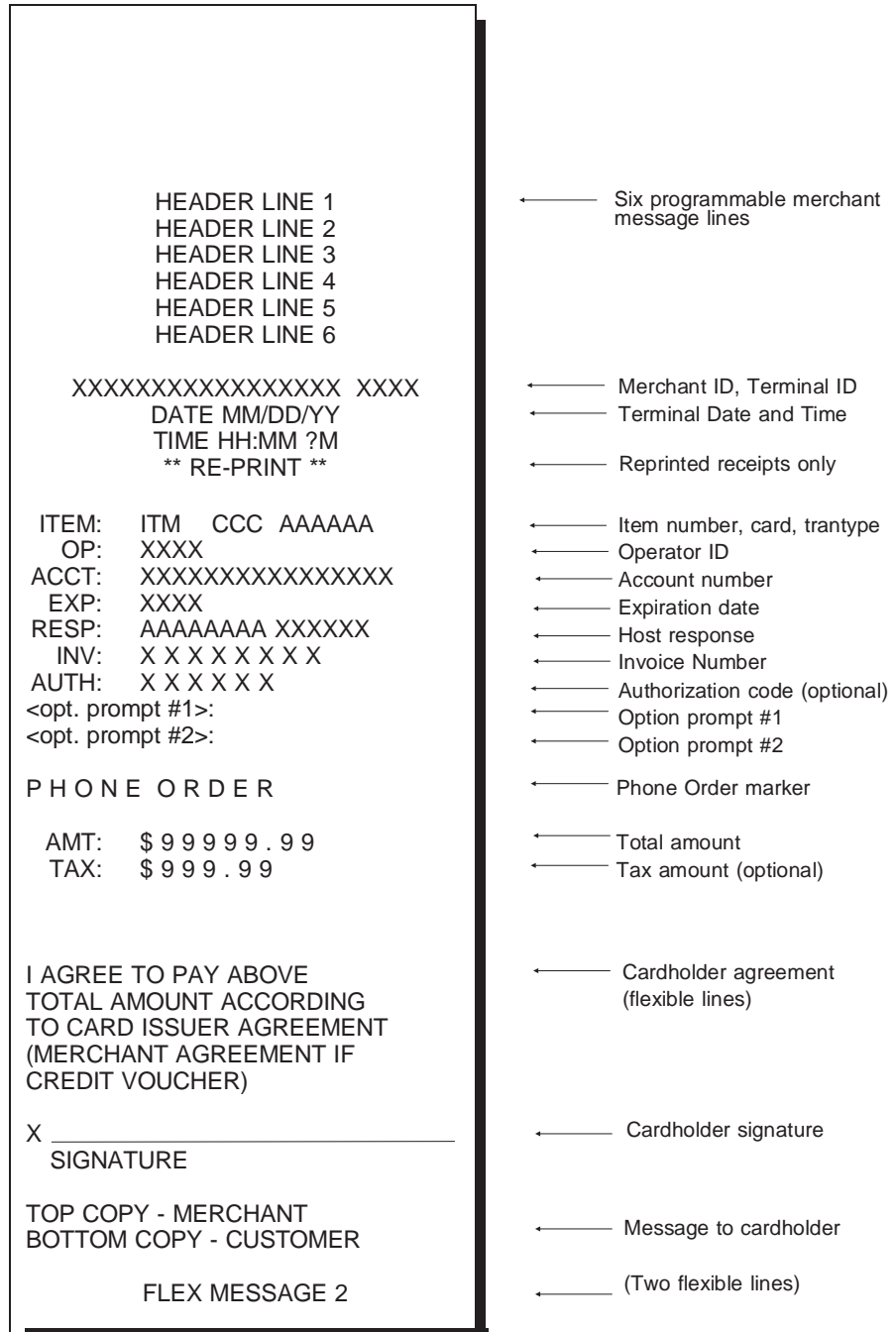

*Figure A-1. Sample Sale Receipt*



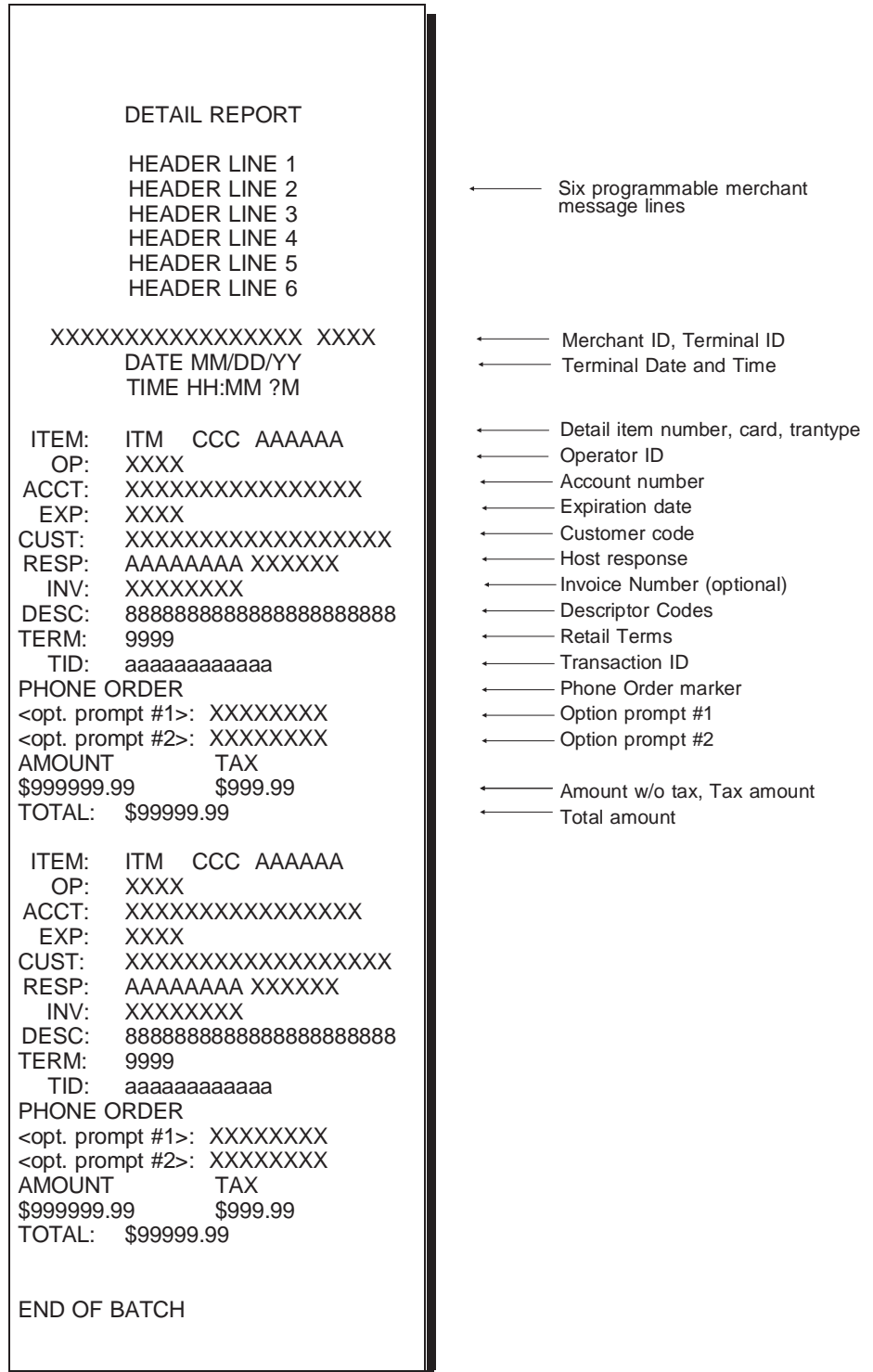

Figure A-2. Sample Detail Report

# FDC Retail/Debit Purchasing Card Reference Manual

---

TOTALS REPORT				
HEADER LINE 1				← Six programmable merchant message lines
HEADER LINE 2				
HEADER LINE 3				
HEADER LINE 4				
HEADER LINE 5				
HEADER LINE 6				
XXXXXXXXXXXXXXXXXXXX XXXX				← Merchant ID, Terminal ID ← Terminal Date and Time
DATE MM/DD/YY				
TIME HH:MM ?M				
#	TRAN	COUNT	AMOUNT	
	TT	ITM	xxxxxx.xx	← Terminal Total
1	S	nnn	xxxxxx.xx	← Card type 1, Sale total
1	R	nnn	xxxxxx.xx	← Card type 1, Return total
1	VS	nnn	xxxxxx.xx	← Card type 1, Void Sale total
1	VR	nnn	xxxxxx.xx	← Card type 1, Void Return total
2	S	nnn	xxxxxx.xx	← Card type 2, Sale total
.	.	.	.	
.	.	.	.	
.	.	.	.	
10	S	nnn	xxxxxx.xx	← Card type 10, Sale total
10	R	nnn	xxxxxx.xx	← Card type 10, Return total
10	VS	nnn	xxxxxx.xx	← Card type 10, Void Sale total
10	VR	nnn	xxxxxx.xx	← Card type 10, Void Return total
DEBITS	T	nnn	xxxxxx.xx	← Debit count and amount

*Figure A-3. Sample Totals Report*

OPERATOR TOTALS REPORT	
XXXXXXXXXXXXXXXXXXXX XXXX	
DATE MM/DD/YY	
TIME HH:MM ?M	
AAAA CARD TOTAL	\$999999.99
AAAA CARD TOTAL	\$999999.99
AAAA CARD TOTAL	\$999999.99
AAAA CARD TOTAL	\$999999.99
AAAA CARD TOTAL	\$999999.99
END OF OPERATORS	

← Merchant ID, Terminal ID  
← Terminal Date and Time  
← Operator ID, Total

Figure A-4. Sample Operator Totals Report

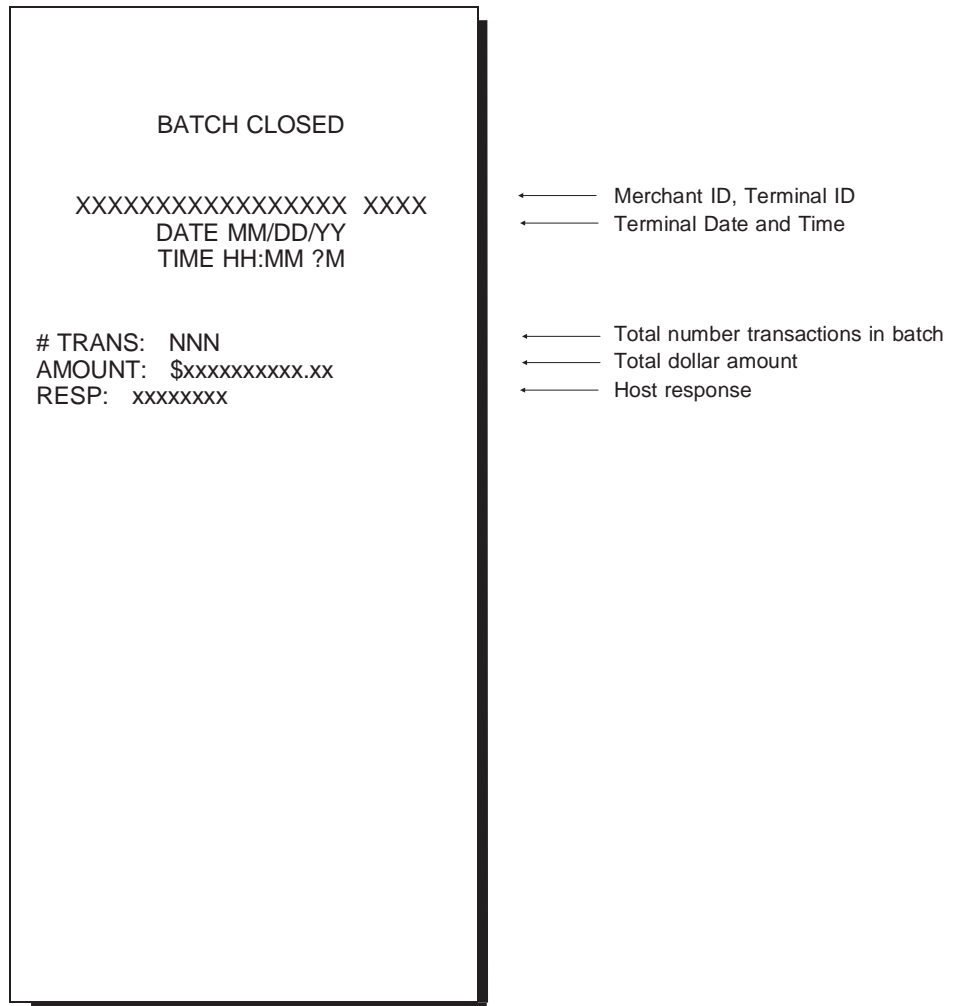

Figure A-5. Sample Batch Closed Header

*Note: The batch number "xxxxxxx" appears in the form the user entered. It appears as blanks if the user pressed [ENTER] to bypass this field during the transaction. If the batch number option is set to OFF, a blank line appears instead of the batch number line.*

# ***Appendix B. PINpad 101 Device***

---

## ***Introduction***

---

The PINpad 101 data entry device accepts personal identification numbers (PINs) for Debit card transactions. The PINpad 101 device uses a master key and a working key to encrypt the PIN input. Typically, a PIN is a 4- to 12-digit code known only by the customer and the bank. A PIN is used during retail transactions to verify that the customer is authorized to use the credit card offered; the PIN also serves as the cardholder identification for the credit or debit transaction.

The PINpad unit connects to a TRANZ 460 terminal that controls PIN entry operations and does the actual communication with the host computer.

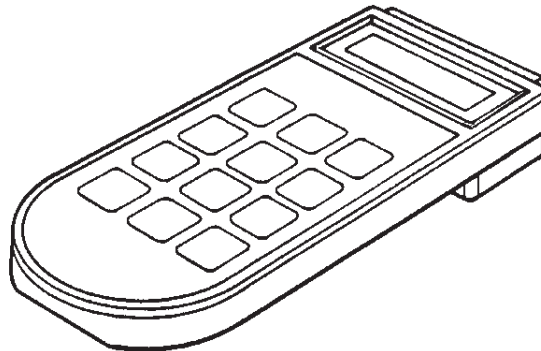

*Figure B-1. PINpad 101*

## ***PINpad Device Components***

---

The PINpad device components include:

- 8-character display
- 12-key telephone-style keypad

### **Display**

The 8-character display shows up to 16 characters through automatic scrolling. The PINpad 101 device displays fully-formed numerals, letters and special characters \* and #. Information displayed includes characters entered from the keypad, instructions, prompts and error messages.

### Keypad

The keypad's 12 keys are used for PIN and data entry and manual diagnostics. Please see the PINpad 101 Reference Manual, Part Number 10420, for further details on diagnostic procedures and programming.

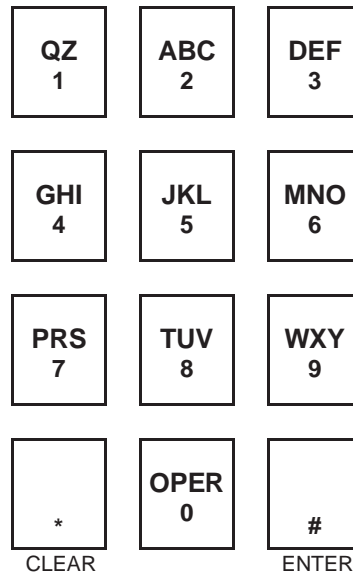

Figure B-2. PINpad 101 Device Keypad

## Selecting a Location for the PINpad Device

---

Select a location for the PINpad device that is convenient for the customer and offers adequate ventilation and protection for the unit.

In general, avoid areas with:

- Excessive heat
- Oil or moisture
- Excessive dust
- Excessive electrical noise (caused by air conditioners, motors, fans or power tools)
- Direct sunlight
- Artificial light that could reflect glare off the display

## Unpacking

Carefully inspect the shipping carton and its content for shipping damage. If the PINpad device was damaged during shipment, immediately file a claim with the shipping company and notify VeriFone, Inc.

*Warning: Do not use the PINpad unit if it has been damaged.*

1. Remove the PINpad unit from the shipping carton.
2. Remove any protective plastic wrap and place the unit on a table or counter top.
3. Remove the protective plastic wrap from the display panel on the top of the PINpad.
4. Replace all the packing materials, close the lid and save the carton for repacking or moving the PINpad device in the future.

## Connecting the PINpad Device to the Terminal

Unplug the terminal power pack before connecting the PINpad 101 device. The PINpad 101 device rear panel has a modular, 4-wire interface port for power and communication connection to the terminal.

*Warning: Turn off or unplug the terminal whenever you connect or disconnect the PINpad. Be sure the terminal is not processing data when you cut power. Memory corruption and data loss can result.*

Figure B-3 illustrates the PINpad 101 unit connection to a TRANZ 460 terminal.

Plug the cable into the PINpad device connector on the rear of the terminal. Use the rubber grommet (cable cover) to protect the cord. See the lower illustrations for more detail.

1. Connect the modular plug on the PINpad cable to the modular jack on the rear of the PINpad unit.
2. Connect the other end of the cable to the PINpad unit port on the side of the terminal.
3. Spread the grommet open and put it on the cord with the narrow end facing the PINpad device.

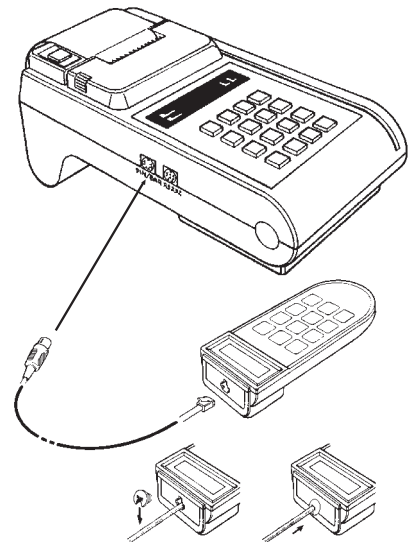

Figure B-3. PINpad 101 Device Cable Connections

- Slide the grommet up the cord and push its narrow end into the modular jack. When properly installed, the grommet should fit flat against the rear of the PINpad device.

Cable Part Numbers	Part No.	Description
	10441-01	0.6 M, coiled (stretches to 7 ft.)
	10441-02	1.1 M, coiled (stretches to 15 ft.)
	01582-00	1 M, straight
	01582-01	3.6 M, straight
	01582-02	7.6 M, straight

### PINpad 101 Device Mounting

The optional PINpad mount holds your PINpad unit securely to a counter top or a wall. The PINpad device can be lifted from the mount anytime for hand-held operation.

First select a location for the mount on a smooth wall or countertop. Be sure the cable can easily reach the terminal from this position without stretching.

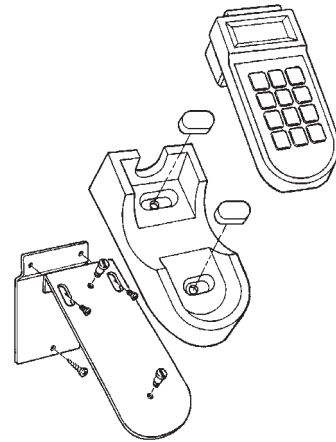

Figure B-4. PINpad Unit Mount Components (Exploded View)

#### Wall Mounting

- Screw the flat wall plate securely to the wall as shown in Figure B-4. Use screw anchors if you are fastening the mount to a cement or brick wall. If you are fastening the plate to drywall, the screws must go into the studs behind the wall. Screw anchors alone will not safely hold the PINpad mount to drywall.
- Fasten the angled metal bracket to the wall mount using the TORX machine screws provided. The two slots on the bracket allow a TORX screwdriver to reach these screws.
- Insert the two large slotted screws into the top of the angled bracket but do not tighten them yet.
- Position the keyholes on the molded cradle over the slotted screws on the angled bracket. Slide the mount to the right until both screws are in the narrow ends of the keyholes. If necessary, loosen the screws slightly until the cradle slides easily.
- Tighten the slotted screws to secure the cradle to the angled bracket. Insert the small molded covers to conceal the keyholes.
- Place the PINpad device firmly into cradle.



### Countertop Mounting

1. To secure the cradle, screw the wood screws into the counter top through the narrow ends of the keyholes. If you do not want to make any holes, use the double-faced tape provided with the wall mount.
2. Place the PINpad device firmly into the cradle.

## PINpad Device Startup

If the PINpad master keys are loaded, the unit automatically starts up when connected to the terminal. Upon startup, the PINpad device briefly displays the version and date followed by the idle prompt.

## The Idle Prompt

The PINpad device displays rows of characters that resemble a marching arrow ( <- - - - -). This is the idle prompt and indicates the device is ready for use. This application sets the idle prompt via a ZONTALK download.

## Using the Keypad

The PINpad unit has 12 keys—much like a standard telephone—and includes letters A through Z, numerals 0 through 9 and special characters \* and #.

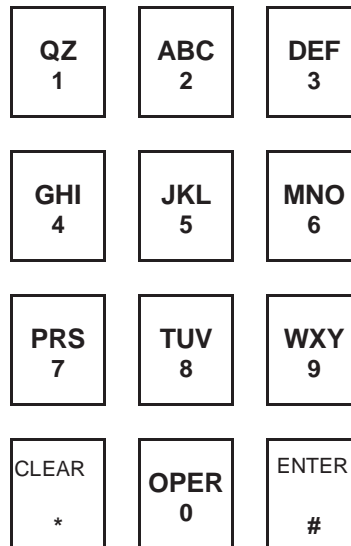

Figure B-5. PINpad Keypad

To complete a transaction, the PINpad device displays a prompt requesting PIN entry. Enter your PIN number and press [ENTER]. The device rotates a processing display when it successfully receives the PIN entry.

*Note: To clear the PINpad unit display to reenter a PIN, press [CLEAR].*

Refer to the appropriate PINpad Reference and Programmer's Manual, for more complete details, including diagnostic procedures and programming considerations. See list of part numbers on page B-7.

## Maintenance

VeriFone follows stringent quality control standards in manufacturing all PINpad devices. Each unit receives numerous tests before leaving the factory to ensure quality and reliability. However, should you encounter a problem in operation, read this section for possible causes and solutions.

### **Cleaning**

Periodically clean the PINpad device with a clean cloth dampened with water and a mild soap or cleaner. Do not use harsh chemicals.

*Warning: Because your PINpad device can be damaged by liquids, do not spray liquid cleaners directly on the unit. Always apply the cleaner to the cloth before cleaning the PINpad device.*

### **Returning the PINpad Device**

If you need to return your PINpad unit for service or replacement, call the toll free number given below and ask for the VeriFone MRA (Merchant Return Authorization) desk. Be sure to mention the serial number found on the bottom of your unit.

If phoning from the United States, call 800-834-9133.

If phoning from outside the United States, call 714-979-1870.

*Warning: Do not try to service, repair or adjust the PINpad device in any other way. Return the unit to VeriFone if it does not operate properly.*

Send the malfunctioning PINpad device with approved MRA number to VeriFone, Inc. 3080 Airway Ave., Costa Mesa, CA 92626 for repair or replacement.

### **Troubleshooting**

These troubleshooting guidelines identify various problems and the appropriate corrective action. If you have a problem with your PINpad device, read these troubleshooting examples. If your problem persists or is not listed here, call the toll free number (800-834-9133) and ask for the VeriFone MRA (Merchant Return Authorization) desk. You must have an MRA desk approval before returning your equipment for repair.

*Warning: Turn off or unplug the terminal whenever connecting or disconnecting it from the PINpad device. Do not turn off or unplug the controller while it is processing; memory corruption and data loss can result.*

<b>Problem</b>	<b>Solution</b>
Display Panel does not work	<ol style="list-style-type: none"><li>1. Check all your cable connections.</li><li>2. Check your terminal's AC outlet to be sure it's supplying sufficient power; substitute the terminal's power pack with another power pack.</li><li>3. Your application program might not be loaded correctly; download the application program and try again.</li><li>4. Run display reliability test as described in the PINpad 101 Reference and Programmer's Manual, Part Number 10420.</li></ol> <p>If the problem persists, phone the VeriFone MRA desk.</p>
Keypad does not respond	<ol style="list-style-type: none"><li>1. Check your display panel. If the wrong characters are displayed or nothing at all, refer to the solutions for previous problem.</li><li>2. Run manual keypad diagnostic as described in the PINpad 101 Reference and Programmer's Manual.</li></ol> <p>If the problem persists, phone the VeriFone MRA desk.</p>

### **Documentation**

PINpad 101 Reference and Programmer's Manual, Part Number 10420, Revision C.

### **Part Numbers**

<b>Unit</b>	<b>Part Number</b>
PINpad 101 Device	P003-106-02



# ***Appendix C. PINpad 201 Device***

---

## ***Introduction***

---

The PINpad 201 data entry device, VeriFone Part Number P003-120-05, accepts Personal Identification Numbers (PINs) during debit card transactions. The PINpad 201 device uses a master key and a working key to encrypt PIN input. The PIN verifies that the customer is authorized to use the debit card offered and serves as an electronic signature for the transaction.

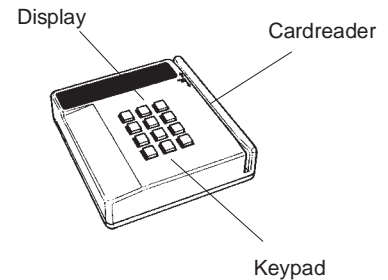

*Figure C-1. PINpad 201*

## ***PINpad 201 Device Components***

---

The PINpad device components include:

- 16-character display
- Magnetic cardreader
- Push button telephone-like keypad

## ***Selecting a Location for the PINpad Device***

---

Select a location for the PINpad device that is convenient for the customer and offers adequate ventilation and protection for the unit.

In general, avoid areas with:

- Excessive heat
- Oil or moisture
- Excessive dust
- Excessive electrical noise (caused by air conditioners, motors, fans or power tools)
- Direct sunlight
- Artificial light that could reflect glare off the display

### Unpacking

Carefully inspect the shipping carton and its contents for shipping damage. If the PINpad 201 unit was damaged during shipment, immediately file a claim with the shipping company and notify VeriFone, Inc.

*Warning: Do not use the PINpad unit if it has been damaged.*

1. Remove the PINpad device from the shipping carton.
2. Remove any protective plastic wrap and place the unit on a table or countertop.
3. Remove the protective plastic wrap from the display panel.
4. Replace all the packing materials, close the lid and save the carton for repacking or moving the PINpad device in the future.

### Connecting the PINpad Device to the Terminal

The PINpad 201 device rear panel has a modular, 4-position interface port for power and communication connection to the TRANZ 460. (The rear panel also has a power pin connector, which is not used for this system implementation.) Figure C-2 illustrates how to connect the PINpad unit to the TRANZ 460. For other terminal connections, refer to Section 3 of this manual.

*Warning: Turn off or unplug the terminal whenever you connect or disconnect the PINpad device. Be sure the terminal is not processing data when you cut power. Memory corruption and data loss can result.*

1. Turn off or unplug the power to the terminal.
2. Connect one end of the cord to the terminal.
3. Connect the other end of the cord to the PINpad device.
4. Turn on or plug in the power to the terminal.

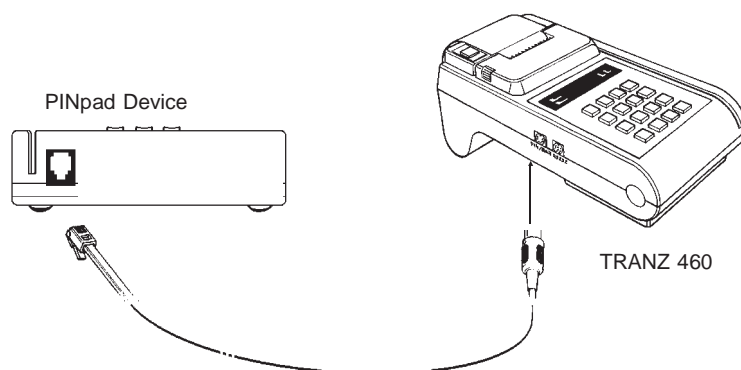

Figure C-2. PINpad Device to TRANZ 460 Connection

<b>Cable Part Numbers</b>	<b>Part No.</b>	<b>Description</b>
	10441-01	.6 M, coiled (stretches to 7 ft)
	10441-02	1.1 M, coiled (stretches to 15 ft)
	01582-00	1 M, straight
	01582-01	3.6 M, straight
	01582-02	7.6 M, straight
	02597-01	Adapter, gender change
	02598-01	Adapter, gender change
	10776-01	Interface to PC
	10776-02	Interface to AT

### **Cable Routing Channels**

The cable routing channels, located under the unit, allow you to route the modular cord to the front of the PINpad device instead of the rear. Front routing is especially convenient for wall mounting.

1. Turn the PINpad unit upside down and locate the cable channel.
2. Insert a section of the cable into the channel closest to the cable plug.
3. Be sure the cable is straight and nested securely in the channel.
4. Turn the PINpad unit right side up and position it with the cords neatly out of the way.

## **PINpad 201 Device Mounting**

VeriFone offers optional wedge and flat mounts for use with the PINpad device. A wedge mount inclines or lifts the unit when mounting on counter tops or walls. A flat mount allows you to attach the PINpad device to a flat surface.

## **PINpad Device Startup**

If the master keys are loaded, the PINpad unit automatically starts up when connected to the terminal. Upon startup, the PINpad device briefly displays the version and date followed by the idle prompt.

## **The Idle Prompt**

The PINpad device, by default, displays rows of characters that resemble a marching arrow ( <-----). This represents the idle prompt and indicates the unit is ready for use.

The display of the PINpad device idle prompt can be downloadable. For example, the idle prompt display may be customized to display a "WELCOME" message.

### Using the Cardreader

The cardreader reads data quickly and accurately and is generally the preferred method since the card swipe lessens the chance for human error. However, manual keypad entry is useful if a card is damaged or when an order is being taken by phone or mail.



Figure C-3. PINpad Device Cardreader

1. Check the display for the idle prompt. If not displayed, press [CLEAR] twice to cancel any current operation and display the idle prompt.
2. Hold the card so the magnetic stripe is down and facing left (toward the keypad or the center of the PINpad).
3. Insert the card in the rear of the slot and briskly slide it through the cardreader toward the front of the PINpad.

If the PINpad device cannot read the card number, it displays PLEASE TRY AGAIN. Check how you are holding the card and slide it through the slot again. If the number still cannot be read, enter the number on the keypad followed by [#/ENTER].

### Using the Keypad

The PINpad 201 unit has 12 keys—much like a standard telephone—and includes letters A through Z, the numerals 0 through 9 and special characters \* and #.

To enter your personal identification number to complete a transaction, the PINpad displays a prompt requesting PIN entry. Enter your number and press [#]. The PINpad device rotates a processing display when it successfully receives the PIN entry.

*Note: You can clear the PINpad unit display to reenter a PIN by pressing [CLEAR]. Refer to the PINpad 201 Reference and Programmer's Manual, P/N 10297 for more complete details including diagnostic procedures and programming considerations.*

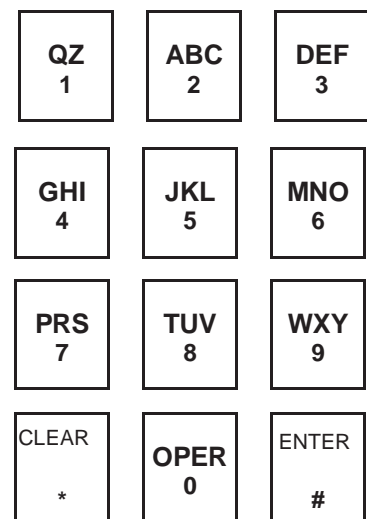

Figure C-4. PINpad 201 Keypad



"THANK YOU" appears for 3 seconds at the end of the transaction. The PINpad device then returns to the idle prompt.

## ***Maintenance and Keypad Diagnostics***

---

VeriFone follows stringent quality control standards in manufacturing all PINpad devices. Each unit receives numerous tests before leaving the factory to ensure quality and reliability. However, should you encounter a problem in operation, read this section for possible causes and solutions.

### **Cleaning**

Periodically clean the PINpad device with a clean cloth dampened with water and a mild soap or cleaner. Do not use harsh chemicals.

*Warning: Because your PINpad unit can be damaged by liquids, do not spray liquid cleaners directly on the device. Always apply the cleaner to the cloth before cleaning the PINpad device.*

### **Returning the PINpad Device**

If you need to return your PINpad unit for service or replacement, call the toll free number given below and ask for the VeriFone MRA (Merchant Return Authorization) desk. Be sure to mention the serial number found on the bottom of your unit.

If phoning from the United States, call 800-834-9133.

If phoning from outside the United States, call 714-979-1870.

*Warning: Do not try to service, repair or adjust the PINpad device in any other way. Return the unit to VeriFone if it does not operate properly.*

Send the malfunctioning PINpad device with approved MRA number to VeriFone, Inc. 3080 Airway Ave., Costa Mesa, CA 92626 for repair or replacement.

### **Troubleshooting**

These troubleshooting guidelines identify various problems and the appropriate corrective action. If you have a problem with your PINpad unit, read these troubleshooting examples. If your problem persists or is not listed here, call the toll free number (800-834-9133) and ask for the VeriFone MRA (Merchant Return Authorization) desk. You must have MRA desk approval before returning your equipment for repair.

*Warning: Turn off or unplug the terminal whenever connecting or disconnecting it from the PINpad device. Do not turn off or unplug the terminal while it is processing; memory corruption and data loss can result.*

<b>Problem</b>	<b>Solution</b>
Display Panel does not work	<ol style="list-style-type: none"><li>1. Check all your cable connections.</li><li>2. Check your terminal's AC outlet to be sure it's supplying sufficient power; substitute the terminal's power pack with another power pack.</li></ol>

## FDC Retail/Debit Purchasing Card Reference Manual

---

<b>Problem</b>	<b>Solution</b>
	<ol style="list-style-type: none"><li>3. Your terminal's application might not be loaded correctly; download application and try again.</li><li>4. Run display reliability test as described in the PINpad 201 Reference and Programmer's Manual, Part Number 10297.</li></ol> <p>If the problem persists, phone the VeriFone MRA desk.</p>
Keypad does not respond	<ol style="list-style-type: none"><li>1. Check your display panel. If the wrong characters are displayed or nothing at all, refer to the solutions for previous problem.</li><li>2. Run the manual keypad diagnostic as described in the PINpad 201 Reference and Programmer's manual.</li></ol> <p>If the problem persists, phone VeriFone MRA desk.</p>
Cardreader does not work	<ol style="list-style-type: none"><li>1. Perform your transaction using several debit cards to ensure problem is not a defective card. When sliding cards through the cardreader, be sure the magnetic stripe is down and facing left.</li><li>2. Verify that Message Q3, Ignore Card Swipe, has not been used.</li><li>3. Verify that Message Q4, Turn Cardreader On/Off is turned on.</li><li>4. Your terminal application may not be properly loaded. Download your application and try again.</li><li>5. Perform Cardreader Diagnostic, described in the PINpad 201 Reference and Programmer's Manual, Part Number 10297.</li><li>6. Enter the information manually from the keypad. If the transaction works, phone the VeriFone MRA desk.</li></ol>

# Appendix D. Prompts and Error Messages

---

The following list includes the prompts and error messages that may appear on your terminal's display. The list consists of two columns:

- The left column is the message or prompt
- The right column contains an explanation of the message and any appropriate required response.

<b>ACCEPTED itm</b>	Approval response if the transaction was performed offline. Press [CLEAR] to return to the idle prompt.
<b>ACCT RANGE ITEM?</b>	Enter the account range item number 1–9, then continue to answer all prompts.
<b>ALREADY VOIDED</b>	Display indicating that the transaction selected to be voided has already been voided. Press [CLEAR] to return to the idle prompt.
<b>AMEX SPLIT Y/N</b> <b>AMEX PRIMARY #?</b> <b>AMEX SECOND #?</b> <b>AMEX MERCH ID?</b> <b>AMEX CARD TYPE?</b>	Host setup prompts. If you select "Y" for AMEX host split dial, continue with the remaining prompts. Select "N" to disable split dial and go to the Discover host prompts.
<b>AMOUNT OF SALE ?</b>	Enter the total amount of the sale without the decimal, then press [ENTER].
<b>APPROVED: nnnnnn</b>	Approval number on AUTHORIZATION ONLY transactions sent from the host.
<b>AUTH ONLY</b>	Display when key [3] is pressed when initiating procedures to authorize a sale. Wait for the next prompt.
<b>AUTO CLOSE Y/N</b> <b>CLOSE TIME HH:MM</b>	Select "Y" for the terminal to automatically close, then enter the close time in 24-hour format and press [ENTER]. Select "N" for no auto close.

## FDC Retail/Debit Purchasing Card Reference Manual

---

<b>AVS ADDRESS</b>	Enter the cardholder's street address, then press [ENTER].
<b>AVS ZIP</b>	Enter the cardholder's ZIP code, then press [ENTER].
<b>BANKCARD ADDRESS</b> 99999999999999999999999999999999	Prompt that appears if you select "Y" at the ENABLE DDOV? prompt. Press [ENTER] to accept the current address, or key in a new host address, up to 20 alphanumeric characters, then press [ENTER].
<b>BATCH IS FULL</b>	Indicates that data capture memory is full and no more transactions can be stored in memory until data capture file is cleared.
<b>CALL CENTER</b>	Operator should call the credit authorization center voice line.
<b>CARD=1 OP=2</b>	In a Totals Review function, press "1" to review totals by card type or "2" to review operator totals. This prompt also appears in the Print Totals Report function.
<b>CARD RANGE INFO</b> <b>ACCT RANGE ITEM?</b> nn-LOW? nn-HIGH? nn-CARD TYPE? nn-CARD ABBREV? nn-TERMS? Y/N nn-DES CODE 0/2/4 nn-AVS ? Y/N nn-CUST CODE? Y/N	Setup Code 2 was entered allowing the operator to enter card range information.  <i>Note: You must answer ALL prompts. Press [9] or [6] for "Y" and "N" responses. At the Customer Code, prompt, enter 1 to 25 numeric digits.</i>
<b>CLEAR BATCH</b>	Display when Code 9 of the Setup function is selected. Wait for the next prompt.
<b>CLEAR? Y/N</b>	Setup function Code 9 allowing the operator to clear the terminal buffer and return to the setup mode. Press "Y" to continue or "N" to exit the function.
<b>CLOSE BATCH</b>	The Close Batch transaction, Key [9], was selected.
<b>CLOSING &gt;&gt;&gt;&gt;</b>	Close Batch display when the terminal is closing with the host.
<b>COMMUNICATING</b>	Display when the terminal is sending or receiving data from the download host.

## Appendix D. Prompts and Error Messages

---

<b>CONNECTED</b>	The terminal has connected with the host computer and is ready to begin communicating.
<b>CREDIT=0 DEBIT=1</b>	Select "1" for debit transactions, or "0" for credit transactions. Wait for the next prompt.
<b>CURRENTLY YES CURRENTLY NO</b>	Display that appears following the ENABLE DDOV? Y/N prompt, showing the current communications DDOV setting (YES or NO). Press [ENTER] to accept the current setting. Press [9] for YES, or [6] for NO to change the setting.
<b>CUSTOMER CODE</b>	Enter the customer code, up to 25 alphanumeric characters, then press [ENTER].
<b>CUSTOMER CODE? Y/N</b>	Account Range setup option. Select "Y" for the terminal to prompt for entry of the customer code during specific transactions, or "N" for no prompt.
<b>DEBIT? Y/N</b>	Press "Y" to enable debit transactions, or "N" to disable.
<b>DECLINED</b>	The host computer has declined authorization of a transaction.
<b>DEMO Y/N</b>	Display when you press [FUNC] [3] to place the terminal in Demo mode. Select "Y" or "N" as desired, then wait for the next prompt.
<b>DESC CODE</b>	Enter the descriptor codes, up to four sets, then press [ENTER].
<b>DETAIL</b>	Display indicating print Option 1, audit detail, was selected.
<b>DIALING</b>	The terminal is dialing the host computer.
<b>DISC SPLIT Y/N DISC PRIMARY #? DISC SECOND #? DISC MERCH ID? DISC CARD TYPE?</b>	Host setup prompts. If you select "Y" for Discover host split dial, continue with the remaining prompts. Select "N" to disable split dial.
<b>DOES NOT BALANCE</b>	Display indicating the amount keyed in at the time of the Close is not in agreement with the terminal balance.

## FDC Retail/Debit Purchasing Card Reference Manual

---

<b>DOWNLOAD DONE</b>	Display after completion of successful download.
<b>ENABLE VPL? Y/N</b>	Host setup prompt. Press [9] for "Y" to enable VPL communications, or [6] for "N" to disable.
<b>END OF BATCH</b>	Display in an Item Review function indicating the last item in the batch was reviewed. Press [CLEAR] to return to the idle prompt.
<b>itm ENTER ACCT #</b>	Enter the account number on the keyboard or slide the card through the cardreader. "itm" is the transaction item number, for example 001, 002, 010, etc.
<b>ENTER AMOUNT</b>	Enter the terminal total dollar amount of the batch you wish to close, then press [ENTER].
<b>ENTER AUTH CODE</b>	Enter the authorization code up to six alphanumeric characters, then press [ENTER].
<b>ENTER CARD TYPE</b>	When reviewing terminal totals and detail transactions, press [1], [2]....[6] for the card type you wish to review.
<b>ENTER ID NUMBER</b>	Enter the ID number on the keyboard, then press [ENTER].
<b>ENTER INVOICE #</b>	Enter the invoice number for the transaction, then press [ENTER].
<b>ENTER ITEM #</b>	Enter the item number of the transaction to review, or press [ENTER] to review the first item in the batch.
<b>ENTER NEW PASSWD</b>	Enter the new manager password, then press [ENTER].
<b>ENTER PASSWORD</b>	Enter the manager password, then press [ENTER].
<b>ENTER PIN PUSH "ENTER"</b>	PINpad device prompt after it displays the debit transaction amount. The customer should enter his/her PIN on the PINpad device, then press the [ENTER] key.

## Appendix D. Prompts and Error Messages

---

<b>ENTER SETUP CODE</b>	Enter the code that corresponds to the selected option during a terminal setup function.
<b>ENTER TO CONFIRM</b>	Void transaction prompt. Press [ENTER] to confirm voiding the selected transaction record.
<b>ENTER TRAN CODE</b>	Enter the numeric transaction code, then press [ENTER] when requesting check authorization.
<b>EXPIRY DATE MMY</b>	Enter the 4-digit expiration date using two digits each for the month and year, then press [ENTER].
<b>FUNCTION?</b>	Prompt when the [FUNC/ENTER] key is pressed asking which function the operator wishes to initiate.
<b>HOST INFO</b> <b>FDR PRIMARY #?</b> <b>FDR SECOND #?</b> <b>FDR CLOSE PHONE?</b> <b>FDR MERCH ID?</b>	Setup Code 1 was selected. Enter the required interactive host information.
<b>IDLE PROMPT</b>	Code 8 of the Setup function was selected. Press [ENTER] to leave the idle prompt unchanged. Press [BACKSPACE] and enter up to 16 alphanumeric characters to change the idle prompt, or [BACKSPACE] and [ENTER] to keep the default idle prompt READY **nnn**.
<b>INQUIRY</b>	Display indicating Key [6] was pressed. Wait for the next prompt.
<b>NO ENQ FROM HOST</b>	The terminal did not see the ENQ character from the host. Repeat the transaction, and if you receive the same message, call your authorization center for help.
<b>NO MERCHANT ID</b>	Display when a transaction is initiated and the merchant ID number was not entered in its memory location. Press [CLEAR] to return to the idle prompt, and follow procedures to enter the merchant ID number in the correct location.
<b>NO TEL NUM</b>	Display when a transaction is initiated and the host telephone number was not entered in its memory location. Press [CLEAR] to return to the idle prompt, and follow procedures to enter the telephone number in the correct location.

## FDC Retail/Debit Purchasing Card Reference Manual

---

<b>NO TRANSACTIONS</b>	Display when the operator attempts to close, review or print a batch and there are no transactions stored in the terminal's memory. Press [CLEAR] to return to the idle prompt.
<b>NOT FOUND</b>	The terminal cannot find the item number of transaction to review that has been entered by user. Press [CLEAR] to return to the idle prompt.
<b>OPERATOR ID</b>	Enter the 4-digit operator ID number, then press [ENTER].
<b>OPTION FIELD Y/N</b>	Options setup prompt. Press [9] for "Y" to enable the extended prompt fields, or [6] to disable.
<b>OPTIONS</b> <b>DEVICE ID?</b> <b>INVOICE #? Y/N?</b> <b>OPERATOR ID? Y/N</b> <b>PHONE ORDER? Y/N</b> <b>RECEIPT? Y/N</b> <b>PREPRINT? Y/N</b> <b>AUTO REPORT? Y/N</b> <b>AUTO INSERT? Y/N</b> <b>PREDIAL? Y/N</b> <b>MAN ENTRY? Y/N</b>	Setup Code 5 was entered enabling the operator to enter the terminal identifier and application options.  <i>Note: Answer all prompts. Press [9] and [6] for "Y" and "N" responses.</i>
<b>OUT OF PAPER</b>	Message indicating the integral printer is out of paper when you attempt to initiate a Debit transaction. The terminal returns to the idle prompt.
<b>PASSWORD?</b>	Enter the system password, then press [ENTER], to unlock the terminal's memory. The display echoes each entry with an asterisk (*).
<b>PASSWORD UPDATED</b>	Display that indicates new manager password was updated correctly. Press [CLEAR] to return to the idle prompt.
<b>PHONE ORDER? Y/N</b>	Select "Y" if the transaction is a phone order, or "N" if it is not, then press [ENTER].
<b>PLEASE TRY AGAIN</b>	The cardreader was unable to read the card swipe. Slide the card again.
<b>PRINT OPTION?</b>	Enter [1] to print detail items, [2] to print terminal totals, or [3] to reprint the last receipt.



## Appendix D. Prompts and Error Messages

---

<b>PRINTER / PIN PAD PRINTER? Y/N</b>	Setup Code 7 was entered in the Setup function. Enter "Y" or "N" or press [ENTER] to keep the printer already installed. Enter "1" for the PINpad 101 device, or "2" for the PINpad 201 device.
<b>PROGRAMING ERR Ø</b>	If your terminal displays this message, you can attempt recovery by pressing the [3] and [5] keys simultaneously, causing the terminal to recalculate the checksum digit that may be the cause of the error message. An alternate method is to hold down the [1] key and press the [ENTER] key until the calendar/clock reappears on the display, then reload the program.
<b>PROMPT FIELD &lt;#n&gt;</b>	Enter an extended prompt, up to 16 characters, to be used in Sale, Ticket, or Return transactions (N= 1 or 2).
<b>READY *nnn*</b>	The terminal displays "READY" when it is available to process transactions, where nnn = the number of transactions left to be stored in the terminal. For example, READY **3** indicates that there is space for storage of three more transactions.
<b>RECALL WHAT?</b>	Enter the memory location you wish to review.
<b>RECEIVING</b>	The terminal is receiving a response from the host computer.
<b>REPORTING? Y/N</b>	Enter "Y" to print the records in the Close Batch transaction, or "N" to continue with the closing.
<b>RE-PRINT</b>	Display indicating a reprint function was selected.
<b>RETAIL TERMS</b>	Enter the 4-digit retail terms, then press [ENTER].
<b>RETURN</b>	Display when initiating procedures to authorize a return/credit.
<b>SALE</b>	Display when the [1] key is pressed to process a standard credit card sale transaction. Wait for the next prompt.
<b>SALE TYPE DESC &lt;current value&gt;</b>	Setup prompt. Enter the name of the tran type for all Sale transactions, up to seven alphanumeric characters, then press [ENTER], or press [ENTER] to leave unchanged.

## FDC Retail/Debit Purchasing Card Reference Manual

---

### SECURITY

**SET SALE? Y/N**  
**SET RETURN? Y/N**  
**SET AUTH? Y/N**  
**SET VOID? Y/N**  
**SET TICKET? Y/N**  
**SET DEP INQ? Y/N**  
**SET CLOSE?Y/N**  
**SET ITM REV? Y/N**  
**SET TOT REV? Y/N**  
**SET SETUP? Y/N**  
**SET PRINT? Y/N**  
**SET DEMO? Y/N**

Setup Code 3 was entered enabling the operator to set security flags. Press [9] or [6] for "Y" or "N" responses. A "Y" response will require entry of the manager password to perform the selected transaction/function.

### SERIAL # NOT FND

Response from the download host when the terminal serial number stored in Location 0001 does not match valid serial numbers for a download. Perform the Recall function [FUNC] [7] and check the serial number. Correct it if necessary.

### SETUP

[FUNC] [4] was pressed for terminal set up.

### SORT BY ID? Y/N

Enter "Y" to print a detail report by operator number and item number order, or "N" to print a detail report in item number order only.

### STORE WHAT?

Enter the desired memory location (numbers 0000 through 0999) for storing data in the terminal.

### SUCCESSFUL DL

The terminal has successfully completed the download. Press [CLEAR] to return to the idle prompt.

### SWIPE CARD

When a PINpad 101 device is connected to the terminal and you are performing a debit transaction, the terminal displays this prompt to swipe the customer's debit card through the terminal cardreader. If you are using a PINpad 201 device, this prompt appears on the PINpad unit display.

### TAX CALC? Y/N

Options setup prompt. Press [9] for "Y" to enable automatic tax calculation, or press [6] for "N" to disable.

### TAX PROMPT? Y/N

Options setup prompt. Press [9] for "Y" to enable a tax prompt, if you prefer to enter a tax manually, or [6] for "N" to disable.

## Appendix D. Prompts and Error Messages

---

<b>TAX RATE 9.99</b>	Key in the tax rate for the terminal to use when calculating the tax on the transaction amount. This prompt only appears if you select "Y" at the TAX CALC prompt.
<b>THANK YOU</b>	PINpad device display at the conclusion of a successful debit transaction.
<b>TKT ONLY</b>	The [5] key was pressed to dial for an ETC item. Wait for the next prompt.
<b>TRANSMITTING</b>	The terminal is communicating with the host computer.
<b>UNDEFINED CARD</b>	This prompt appears when a card that is not defined in the Account Range table is swiped through the cardreader.
<b>UNREADABLE CARD</b>	The terminal cannot read the card. Press [CLEAR] to return to the idle prompt.
<b>UNSUCCESSFUL DL</b>	The terminal was unable to complete the download. Press the [CLEAR] key and reinitiate the download.
<b>UPDATE PASSWD ENTER NEW PASSWD VERIFY NEW PASSW</b>	Setup Code 4 was entered enabling the operator to update the manager password.
<b>VOID</b>	Display when the [VOID] key is pressed for voiding a transaction that was captured at the host. Wait for the next prompt.
<b>WAITING FOR LINE</b>	The terminal is waiting for the line to become available.
<b>1=PP101 2=PP201</b>	Setup prompt. Press "1" for a PINpad 101 device, or "2" for a PINpad 201 device.
<b>DOV=1 ISDN=2</b>	Host setup if you select "Y" to enable VPL communications. Select "1" for the DOV address, or "2" for the ISDN address.



# Appendix E. ZONTALK 2000

## Download Parameters

---

ZONTALK 2000 is the VeriFone download program that simplifies the process of updating or completely reprogramming your VeriFone terminal. Designed to run on an IBM PC, XT, AT or compatible, ZONTALK 2000 performs modem downloads to your terminals in the field or direct downloads to terminals physically connected via RS-232 cable to the computer's serial port.

To obtain a ZONTALK 2000 download of the FDC Retail Debit Purchasing Card application, you must program the following memory locations with specific information. Refer to Section 4 of this reference manual for an explanation of how to program the contents of a field location.

Location	Information to Enter
----------	----------------------

0000	Enter the phone number of a computer running ZONTALK 2000
0001	Enter the serial number of the terminal.
0019	Enter the application ID (FRET462). Call your customer service representative for the most current application ID.
0960	Enter the download speed. A "2" enables the terminal to download at 1200 baud. A "1" enables the terminal to download at 300 baud.

When you receive a download from ZONTALK 2000, certain memory locations (parameters) will already have a default setting. These settings may be changed later through the terminal setup function or through manual programming of the terminal. The following list contains the ZONTALK 2000 parameters for the FDC Purchasing Card application. The list is organized in four columns containing a description of the contents, the memory location, the data type code, and the field length.

### Data Type Codes

---

Codes	Description	Legal Character Set
A	Alphabet	[A..Z, a..z, #, -, ., space]
N	Numbers	[0..9]
X	Alphanumeric	[space...~]
P	Phone	[0..9, -, *, #, A, L, P, T, space]
Q	Question	[Y, N]
B	Binary	[0, 1]
I	IBM	[full IBM ASCII set]

## ***Memory Locations***

<b>Description</b>	<b>Location</b>	<b>Type/ No. Chars</b>	<b>Contents/ Comments</b>
Download Phone Number	0000	P(20)	
Printer Type Flag	0950	N(1)	2 <empty>=None 2=Roll
Roll Printer Line Feeds	0951	N(5)	5
Download Speed	0960	N(5)	2 (1=300, 2=1200)
Debit Flag	0970	N(1)	1=PP 101 2=PP201
Beep On/Off	0009	B(1)	0
Dial Type	0010	B(1)	0 (T=0 P=1)
Telephone Line Test	0014	N(1)	
Working key/M-key ptr	0016	X(20)	0000000000000000-1
RECALL Password	0017	B(1)	
Terminal Identifier	0858	X(4)	
Security Bit Map	0859	B(12)	00000000100 (See Note 2)
Manager Password	0860	N(6)	123123
Application Options Map	0861	B(10)	0001000110000 (See Note 3)
Split Dial Options Map	0862	B(2)	00
Login String #0	0020	X(60)	3-81636
Login String #1	0021	X(60)	
Header Line #1	0465	X(26)	
Header Line #2	0466	X(26)	
Header Line #3	0467	X(26)	
Header Line #4	0468	X(26)	
Header Line #5	0469	X(26)	
Header Line #6	0470	X(26)	
Cardholder Flex Line	0392	X(40)	I AGREE TO PAY ABOVE TOTAL AMOUNT
Cardholder Flex Line	0393	X(40)	ACCORDING TO CARD ISSUER AGREEMENT
Cardholder Flex Line	0394	X(40)	(MERCHANT AGREEMENT IF CREDIT VOUCHER)
Cardholder Flex Line	0395	X(40)	
Message Line	0396	X(40)	TOP COPY-MERCHANT BOTTOM COPY-CUSTOMER
Message Line	0397	X(40)	
1st Account Range	0043	X(23)	See Note 1 for details
20th Account Range	0062	X(23)	
Track Selection	0081	B(20)	1=Trk 1 2=Trk 2
Max. Trans. Allowed	0235	N(3)	400
Card Names	0363	X(100)	Separate 10 names with "/"

## Appendix E. ZONTALK 2000 Download Parameters

---

Description	Location	Type/ No. Chars	Contents/ Comments
AMEX Card Type Split Dial	0093	N(1)	
Disc. Card Type Split Dial	0094	N(1)	4
Fraud Control Flag	0106	N(3)	
Fraud Control Flag	0206	N(3)	
Fraud Control Flag	0306	N(3)	
Fraud Control Flag	0506	N(3)	
Primary Phone No.	0700	X(32)	
Secondary Phone No.	0701	X(32)	
Call Center Phone No.	0702	X(32)	
Pick-Up Card Phone No.	0703	X(32)	
Merchant ID	0704	X(46)	
Message Format Flag	0705	N(3)	
Fraud Control Flag	0706	N(3)	
Transaction Ctl String	0707	X(120)	
Transaction Prompt	0708	X(16)	
Floor Limit	0709	N(4)	
Resp. Analysis Ctl Str	0710	X(120)	
Auxiliary Ctl String	0711	X(120)	
DDOV Address	0844	X(28)	
ISDN Address	0847	X(28)	
Primary Phone No.	0852	P(30)	
Secondary Phone No.	0853	P(30)	
Merchant ID	0854	X(32)	
Close Phone No.	0855	P(30)	
Close Redial Phone No.	0856	P(30)	
Cardswipe Default key (1-9)	0985	N(1)	1





## Appendix E. ZONTALK 2000 Download Parameters

---

**Note 3** Location 0861, Application Options Map, contains the string for terminal options settings where 0 = Off and 1 = On.

Position	Option
1	Invoice number
2	Operator ID
3	Phone order
4	Receipt printing
5	Pre-printing
6	Auto report
7	Auto-insert
8	Pre-dial
9	Manual entry
10	Tax prompt
11	Tax calc
12	Optional prompts
13	VPL

If you have any questions regarding these parameter settings, contact your VeriFone representative.



# Appendix F. TRANZport 232

---

## Introduction

The TRANZport 232 provides the VeriFone OMNI and TRANZ families of terminals (including the PNC™ 330) the ability to communicate with two RS-232 serial devices instead of one. For example, suppose in addition to using a printer and a PINpad device, you wish to connect your TRANZ 460 to an external modem requiring an RS-232 compatible connection. Without the TRANZport 232, you would not be able to do so because of the RS-232 port limitation. However, using the two connectors on the TRANZport allows *both* the external modem and the printer to be connected at the same time.

Selecting between the two peripheral devices is controlled by the application running in the terminal. Using the above example during a typical transaction, the TRANZ 460 could select the external modem, make connection with the host, get the transaction authorization, and then instruct the printer to print out a receipt.

The TRANZport 232 is extremely compact and fits snugly behind your transaction terminal to save counter space. It also comes with its own power supply and necessary cables.

## Unpacking

Carefully inspect the shipping carton and its contents for any damage that may have occurred during shipment. If the TRANZport 232 is damaged, immediately file a claim with the shipping company or carrier and notify VeriFone, Inc. Do not use damaged equipment.

1. Remove all items from the carton. In a standard configuration you should have:
  - 1 TRANZport 232
  - 1 power pass-thru cable (PN 20074-03)
  - 2 serial interface cables (PN 00446-04)

*NOTE: An optional power pack is available in other configurations.*

2. Remove any protective plastic wrapping from the TRANZport and place all the components on a table or countertop.
3. Reuse this carton and packing material whenever it is necessary to ship or store the TRANZport 232.

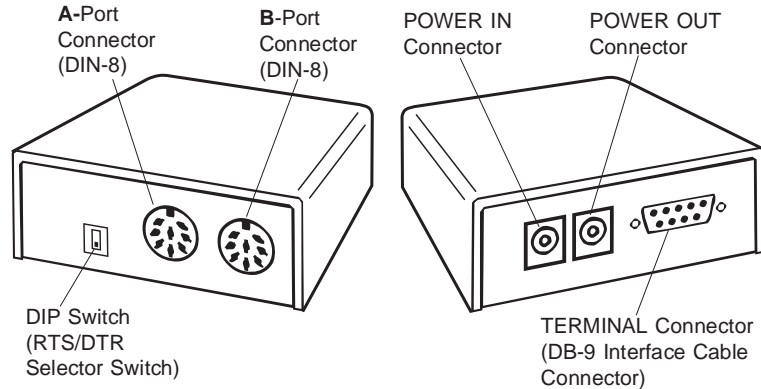

Figure F-1. TRANZport 232 (Front and Rear Views)

### Typical Installation

Use the steps below as a guide to connect a TRANZport 232 in a typical TRANZ 460 configuration.

*Note: In the following configuration the TRANZ 460 receives its power from the TRANZport 232. The power pack that came with your TRANZ 460 should be used with the TRANZport 232. For all other terminal configurations, you should obtain a TRANZ 460 power pack certified for use in your country. If you have purchased a TRANZport 232 configuration containing an optional power pack, use the provided power pack.*

1. Unplug all power cords connected in the present configuration.
2. Disconnect printer from the TRANZ 460 serial port.
3. Plug the disconnected end of the printer serial cable into the connector labeled **A** on the TRANZport 232.
4. Using one of the supplied serial interface cables (PN 00446-04), plug the DIN-8 end into the TRANZ 460 serial port. Plug the DB-9 end of this cable into the connector labeled **TERMINAL** on the TRANZport 232.
5. Plug the DIN-8 end of the second supplied serial interface cable into the connector labeled **B** on the TRANZport 232. The DB-9 end of this cable should be plugged into the DVM (Data Over Voice Multiplexer).
6. Plug one end of the power pass-thru cable into the Power In connector on the TRANZ 460. Plug the other end of this cable into the connector labeled **POWER OUT** on the TRANZport 232. Plug the TRANZ 460 power pack into the connector labeled **POWER IN** on the TRANZport 232.
7. Plug the power pack into an indoor, 120 volt AC outlet.
8. Plug in all other power cords (Printer 150/250, DVM, etc.).

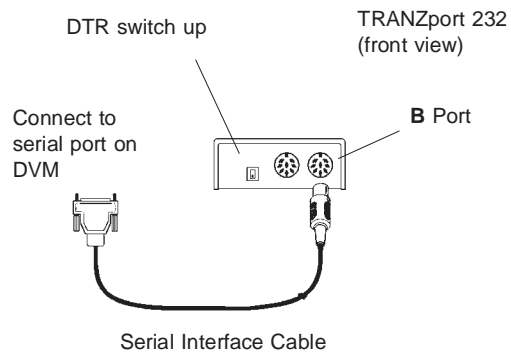

Figure F-2. TRANZport 232 and Data Connections

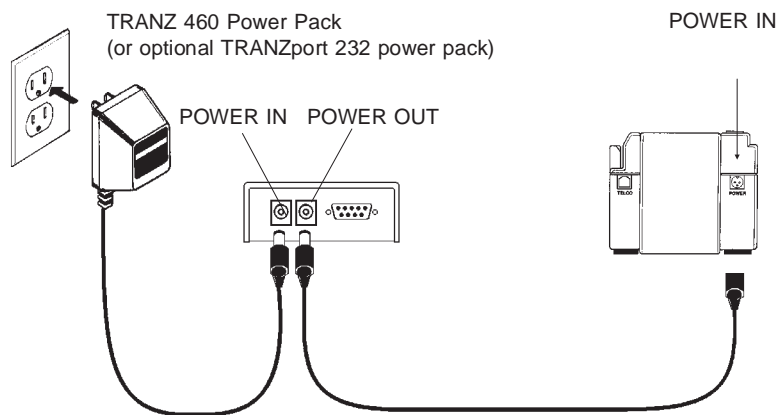

Figure F-3. TRANZport 232 and TRANZ 460 Power Connections

### DIP Switch Setting

The 2-position DIP switch determines which RS-232 control signal, generated by the terminal, is used to select the **A** or **B** port. When the switch is in the up position, DTR is used; when in the down position, RTS is used.

#### DTR (switch up)

- Printer cable in **A** port
- Serial connection to **B** port

In this application, DTR is used with the switch in the **UP** position.

### Testing the TRANZ 460/TRANZport 232 Connection

After connecting the TRANZport as previously outlined, the following TCL code can be used to test the system.

Using the standard recall and edit capabilities of the TRANZ 460, load memory locations 31 and 32 with the following TCL command strings:

```
031=B1.1GR'B PORT TEST'R13R10*R5+R1*I  
032=B1.1GR'A PORT TEST'R13R10*R5+R0*I
```

To test the TRANZport 232 **B** port, press the **[FUNC/ENTER]** key then the **[1]** key on the TRANZ 460 terminal. This sends 'B PORT TEST' to the device connected to the **B** port at 9600 baud.

To test the **A** port, press the **[FUNC/ENTER]** key and then the **[2]** key on the TRANZ 460. This sends 'A PORT TEST' to the device connected to the **A** port at 9600 baud.

When the TRANZ 460 is in the Idle Mode, the TRANZport 232 is connected to the **B** port.

## Specifications

<b>Physical</b>	Height: 1.5 in. (38.1 mm) Width: 3.5 in. (88.9 mm) Depth: 4.0 in. (101.6 mm) Shipping Weight: 1.75 lb (0.8 kg), including cables and power supply
<b>Environmental</b>	Operating Temperature: 0° to 40°C (32° to 104°F) Operating Humidity: 20% to 90%, no condensation
<b>Power</b>	Voltage: 120 VAC, 60 Hz 240 VAC, 50 Hz; 220 VAC, 50 Hz 200 VAC, 50 Hz

## Port Configurations

### Terminal Input Port (9-pin D-sub male connector)

---

pin 1	RTS
pin 2	TxD (from terminal)
pin 3	RxD (to terminal)
pin 4	CTS
pin 5	Signal Gnd
pin 6	RTS (duplicate)
pin 7	DCD
pin 8	RTS (duplicate)
pin 9	DTR

**B Output Port (8-pin DIN connector)**

---

pin 1	Signal Gnd
pin 2	DCD
pin 3	RTS
pin 4	CTS
pin 5	RxD (from external device)
pin 6	TxD (to external device)
pin 7	TxD Idle Level This input sets the state of the TxD output in the the idle state. When open, the idle state of TxD is a mark (-V). When grounded, the idle state of TxD is a space (+V).
pin 8	Aux TxD This output is a TTL version of the RS-232 TxD output, pin 6.

**A Output Port (8-pin DIN connector)**

---

- 1 Signal Gnd
- 2 DCD
- 3 RTS
- 4 CTS
- 5 RxD (from external device)
- 6 TxD (to external device)
- 7 DTR
- 8 +8.5 VDC (used to power PIN pad devices)

**TRANZport 232 Kit**

<u>Part No.</u>	<u>Description</u>
P044-01-002	TRANZport 232
P044-01-001	TRANZport 232, USA Power Pack
01536-01	Power Pack, USA
20074-03	Power Pass-Thru Cable
00446-04	Serial Interface Cable (2 included)

**Service**

Unless otherwise instructed in this reference manual, do not, under any circumstances, attempt any service, adjustments or repairs on this unit. Before returning a unit to VeriFone, call the VeriFone toll free number, 800-834-9133, and ask the service/repair department for an MRA (Merchandise Return Authorization) number. You must have an MRA number prior to returning your requirement for repair.





# Glossary

---

<b>AC</b>	Alternating Current—used as a primary source of power by power packs and power supplies.
<b>Account Number</b>	(1) A unique series or group of digits used to numerically identify each cardholder. (2) The unique identification number assigned to the account of a specific party, within a given institution.
<b>Alpha Mode</b>	A means of allowing you to use the keypad to enter alphabetic characters.
<b>Alphanumeric</b>	Capable of utilizing both alphabetic and numeric characters such as a display panel or keypad or a computer keyboard.
<b>Application</b>	A software program designed with special codes stored in memory for a specific purpose or customer.
<b>Application ID Number</b>	The number identifying which application program is to be downloaded by the ZONTALK software from an IBM PC compatible computer.
<b>ASCII</b>	An abbreviation for American Standard Code for Information Interchange. This standard code is used for transmitting data and is composed of 128 characters in 7-bit binary format.
<b>Asynchronous</b>	Method of transmitting data in which the interval between characters may be of unequal length.
<b>Bar Code</b>	A printed code consisting of vertical lines of varying spacing and thicknesses used for identification purposes. These lines are read by drawing the tip of a bar code wand across them.
<b>Bar Code Wand</b>	A pencil or wand shaped optical scanner for reading bar codes.
<b>Batch File</b>	A file containing a series of transaction details to be processed as a single unit.
<b>Batch Header</b>	A unique heading or title that identifies a batch.

## FDC Retail/Debit Purchasing Card Reference Manual

---

<b>Baud</b>	The signaling speed equal to the number of signal events per second.
<b>Buffer</b>	A temporary storage area.
<b>Byte</b>	A group of consecutive bits that make up a character or a logical unit of information. A byte usually consists of eight bits.
<b>Calendar/Clock Chip</b>	A terminal electronic component that keeps track of the date and time.
<b>Cardreader</b>	The slot on the terminal that automatically reads the magnetic stripe or bar code on the back of a specially encoded card.
<b>Card Security or Fraud Control</b>	Measures taken to prevent unauthorized use of encoded identification cards.
<b>Carrier</b>	A frequency signal or tone sent over the telephone or communication line and modulated by the modem to transmit/receive data.
<b>CCITT</b>	Committee Consultative International Telegraph and Telephone. International committee that sets standards for international data communications.
<b>Character</b>	A standard bit representation of a letter, number, punctuation, figure or other symbol used in a message or in a control function.
<b>Code</b>	Program text representing letters, digits and other data symbols with binary numbers, such as ASCII.
<b>Control String</b>	A series of terminal control language commands linked together to control the execution of a terminal operation.
<b>Copy</b>	To produce a replica of information, usually done to guard against loss or corruption of important records.
<b>CPU</b>	Central Processing Unit. The brain of the computer or terminal that controls either directly or indirectly every function and device associated with the computer/terminal.
<b>Custom Application</b>	An application created to meet the specialized needs of an individual company or institution.
<b>Custom Prompt</b>	A prompt, programmed by a user and stored in one of the terminal's general record memory locations.

<b>Data</b>	Information prepared in a particular format for use by the terminal or host computer for a specific transaction or operation.
<b>Data Entry</b>	The process of using a keyboard or other device to input data directly into a system.
<b>Data Packets</b>	A packet of information transmitted from one device to another.
<b>Default</b>	A value automatically assigned by the program when another value has not been specified.
<b>Delete</b>	To remove a record or item of data.
<b>Diagnostics</b>	The procedure for detecting and isolating a problem with the terminal or peripheral.
<b>Dial-Up Line</b>	A regular public telephone line. The switching equipment on a dial-up line requires that a party dial the other party before a connection can be made.
<b>Display</b>	The small screen on your terminal that displays prompts and messages to guide you through different operations and to alert you when errors or problems occur.
<b>Download</b>	The process of transferring data from one device to another.
<b>EPROM</b>	Erasable Programmable Read-Only Memory. A type of memory chip permanently stored in the terminal. Contains the standard application, operating system and fixed prompts.
<b>File</b>	A collection of logically related records.
<b>Firmware</b>	The basic instructions built into the terminal, stored in ROM and executed automatically.
<b>Fraud Control</b>	Measures taken to prevent unauthorized use of a credit or debit card.
<b>Handshaking</b>	The process of exchanging codes, or control characters, between two devices. The codes are predetermined and establish a connection between both terminals.

## FDC Retail/Debit Purchasing Card Reference Manual

---

<b>Header</b>	Information and codes added to the beginning of user data, such as a transmission block or packet, which contains the destination, address, source address and message number.
<b>Hookswitch</b>	The switch on a telephone instrument that operates when the handset is removed from its cradle.
<b>Host Computer</b>	A central computer used to process transactions; also called a host.
<b>Input</b>	To enter data into a processing system or peripheral device, or the data that is entered.
<b>Idle Prompt</b>	The information shown on the display panel when the device is not performing any operations or transactions. Normally the date and time.
<b>Keypad</b>	The key panel used for entering data and performing operations.
<b>Leased-Line</b>	A private telephone line connected directly to another party.
<b>Line Cord</b>	A telephone type cord with modular plugs for connecting a device to another device or outlet.
<b>Login</b>	Password information for a particular organization that allows access to a system such as a public switched network (e.g., Telenet, Tymnet). The login also opens an accounting file for the session.
<b>Login String</b>	A code consisting of a network code, user name and password used to login to a network.
<b>Luhn Check-Digit</b>	A fraud control measure used in transactions.
<b>Manual Transaction</b>	Transaction using account information entered from the keypad rather than automatic reading devices such as the cardreader.
<b>Memory</b>	The storage of codes and data in the circuitry of a terminal or computer or other media such as magnetic disk or tape.
<b>Memory Dialing</b>	A method of automatically dialing telephone numbers stored in a device's memory rather than dialing by hand.
<b>Memory Location</b>	An exact storage location in the terminal's memory, identified by a 3-digit location number.

<b>Messages</b>	Words and symbols appearing on the display panel which tell you the kind of information required, the result of a process or if an error has occurred.
<b>Modem</b>	Short for modulator/demodulator; a device that converts digital data to analog signals (for transmission over telephone wires) and analog signals back to digital data.
<b>Network</b>	An interconnected group of systems, terminals or data facilities that route numerous transactions and data to the proper terminals and host computers.
<b>Nonvolatile Memory</b>	Memory that retains its contents when power is turned off or lost.
<b>Packet</b>	A group of bits transmitted as a complete package on a packet-switched network. Often called a message.
<b>Parameters</b>	Information stored in memory that sets up the device for use with transactions and other operations.
<b>Password</b>	A confidential code used to gain access to terminal memory or a host computer.
<b>PC</b>	IBM PC or compatible personal computer used to download applications and data to the terminal. A PC can also be used as a local or remote host computer.
<b>Peripheral</b>	An attached device (e.g. a printer or PIN Pad), not the central processing device or computer; typically used for I/O.
<b>PIN</b>	Personal Identification Number. A 4- to 16-digit confidential code or electronic signature used by card holders to identify themselves as the proper users of a credit or debit card to the host computer.
<b>PINpad Device</b>	A Personal Identification Number input device used for entering a private identification code to validate a transaction.
<b>Port</b>	An interface device capable of attaching to a peripheral, computer, network or other electronic device.
<b>POS Terminal</b>	A terminal used at the Point-Of-Sale (POS) that can process transactions and communicate transaction information with a larger remote computer directly or through a network.

## **FDC Retail/Debit Purchasing Card Reference Manual**

---

<b>Post Dialing</b>	A feature that dials the host computer after all of the account and transaction information is entered into the terminal.
<b>Power Pack</b>	A device that converts a voltage to a different level so it can be used by a particular device.
<b>Printer</b>	A device used for imprinting records of a transaction on paper.
<b>Prompt</b>	A message appearing on the display panel telling you what action is required or what type of information to specify.
<b>Pulse Dialing</b>	A method of telephone dialing that specifies a phone number by the number of electrical pulses sent.
<b>Queue</b>	A group of jobs or messages waiting for service. All insertions are made at one end of the queue and all removals and accesses at the other.
<b>RAM</b>	Random Access Memory used to store custom applications and temporary data entered during a transaction.
<b>RECALL</b>	Procedure used to display data in a memory location. RECALL can also be used to add or change data.
<b>Record</b>	A collection of data handled together in transfers.
<b>Refund</b>	Refund transaction credits a customer's account with a refunded amount; the terms "refund" and "return" are used interchangeably.
<b>Remote Host Computer</b>	A host computer requiring connection to the transaction system via a dial-up or leased telephone line.
<b>Remote Host Network</b>	A network that connects the terminal to a remote host computer.
<b>Request Data Packet</b>	A request for information from a terminal to the host computer.
<b>Return</b>	A refund transaction which credits a customer's account with the refunded amount.
<b>Ringer</b>	A bell or alarm on a telephone that announces incoming calls.
<b>ROM</b>	Read Only Memory permanently stored in the device. Contains the standard application program and operating system.

<b>Scroll</b>	To move text across a display screen.
<b>Select</b>	To initiate an action or enable a data path.
<b>Serial Port</b>	An RS-232 connector for communicating with download computers, other terminals, and printers.
<b>Start Up</b>	The sequence that occurs when the terminal is turned on (powered up). This sequence includes turning on power and automatic downloading of configuration data for an application.
<b>STORE</b>	Procedure used to store data in a memory location.
<b>String Constant</b>	A sequence of alphanumeric characters enclosed in single quotation marks; for example, 'SLIDE CARD' or '1997.'
<b>Swipe</b>	The action of sliding a card through a terminal cardreader.
<b>System Password</b>	The password (1[ALPHA][ALPHA]66831) supplied with each TRANZ 460 terminal.
<b>Telephone Jack</b>	Modular type sockets for connecting telephone line cords.
<b>Telephone Line</b>	The standard telephone wiring connecting you to your local or private telephone company.
<b>Terminal</b>	A device used to initiate transactions. The transactions are processed by the terminal itself or by a host computer. These devices have a display panel, keypad, and cardreader, and are used to enter transaction information.
<b>Terminal ID</b>	An identification number used by the download computer to determine what data and application programs to send to an individual terminal or controller.
<b>Terminal Parameters</b>	Parameter data related to a specific terminal.
<b>Timeout</b>	A specified period of time in which the terminal stops processing or undertakes a predetermined alternate action.
<b>Tone Dialing</b>	Also called touch-tone dialing. A method of telephone dialing that uses different pitched tones to specify a phone number.

## **FDC Retail/Debit Purchasing Card Reference Manual**

---

<b>Track 1 Data</b>	Information stored on Track 1 of the magnetic stripe that can be read by the cardreader.
<b>Track 2 Data</b>	Information stored on Track 2 of the magnetic stripe that can be read by the cardreader.
<b>Trunk Cable</b>	A cable to which all the components are connected.
<b>User</b>	The person who is using the terminal.
<b>ZONTALK 2000</b>	A communications program for IBM PC compatible computers used to download applications from the computer to a terminal.



# Index

---

## A

- Accessories ..... 3-11
- Account range
  - setup ..... 5-2
  - range tables ..... 5-3
- Alphabetic characters ..... 4-3
- Auth Only transaction ..... 6-7

## B

- Batch
  - "FULL" indicator ..... 6-1
  - clear ..... 5-9
  - close ..... 6-12
- Beep ..... 3-10

## C

- Cables, PINPad device
  - front routing ..... C-3
- Cables, TRANZport 232 ..... 3-3
- Calendar/clock ..... 4-2
- cardreader
  - features ..... 3-7
  - troubleshooting ..... C-6
- Close Batch ..... 6-12
- Connection, PINpad 201 to TRANZ 380 ..... C-2
- Controller, PINpad 101 device
  - connection ..... B-3

## D

- Data connections ..... 3-3
- Deposit Inquiry ..... 6-11

## DIP switches

- TRANZport 232 ..... F-3
- Display ..... B-1
- Display panel ..... 3-7
  - troubleshooting ..... B-7, C-5
- DTR/RTS Switch settings ..... 3-4

## F

- Field
  - change ..... 4-1
  - emptying ..... 4-3
  - review ..... 4-1
- Fraud control ..... 4-4
- Functions summary ..... 2-3

## G

- Grommet ..... B-3

## H

- Host Setup ..... 5-1

## I

- Idle prompt ..... 5-8, B-5
- Integral printer
  - loading paper ..... 3-6
  - loading/unloading ribbon ..... 3-2
- Item Review ..... 7-1

## K

- Keypad ..... 3-7, B-2
  - clearing entry ..... B-5
  - entry advantages ..... C-4
  - manual entry ..... B-5
  - troubleshooting ..... B-7, C-6

# Index

---

## M

Manual diagnostics	
menu .....	C-6
Memory locations .....	5-9
Mounting	
countertop .....	B-5
wall .....	B-4
MRA (Merchant Return	
Authorization) desk .....	B-6, C-5

## O

On/Feed key .....	3-6
Options setup .....	5-5

## P

Password protection .....	4-5
Password update .....	5-5
PIN (Personal Identification	
Number) entry .....	B-5
PINpad 101 device	
cleaning .....	B-6
components .....	B-1
display characteristics .....	B-1
keypad .....	B-2, B-5
mounting .....	B-4, C-3
selecting location .....	B-2
service/return .....	B-6
startup .....	B-5
troubleshooting .....	B-6
unpacking .....	B-3, C-2
PIN Pad 201 device	
cable routing channels .....	C-3
cardreader operation .....	C-4

cleaning .....	C-5
components .....	C-1
countertop mounting .....	C-3
idle prompt .....	C-3
keypad entry .....	C-4
selecting location .....	C-1
service/return .....	C-5
terminal connection .....	C-2
troubleshooting .....	C-5
wall mounting .....	C-3
PLEASE TRY AGAIN .....	C-4

## Print

batch details .....	7-5
last receipt .....	7-5
operator totals .....	7-5
options .....	7-5
terminal totals .....	7-5

## Printer .....

integral roll .....	A-1
paper detect .....	A-1
specifications .....	A-1
Processing display .....	B-6, C-4
PROGRAMING ERROR,	
eliminating .....	4-5
Programming, general .....	4-1
Public port .....	5-1

## R

Return/credit .....	6-4
Review	
item .....	7-1
programming .....	5-9
totals .....	7-3 - 7-4

# Index

---

## S

Sale ..... 6-1, 6-3, 6-6  
Sale Type description..... 5-7  
Security setup..... 5-4  
Setup codes ..... 5-1  
Software version..... 3-4  
Specifications ..... 3-8, F-4  
Startup ..... B-5, C-3

## T

Terminal  
    cleaning..... 3-8  
    copying..... 4-4  
    functions..... 7-1  
    programming ..... 5-1  
    servicing..... 3-8  
Testing connection ..... F-4  
Ticket Only ..... 6-10  
Transaction storage..... 6-1  
Transaction summary..... 2-3  
TRANZport 232 ..... 3-3  
    data connections..... F-3  
    kit part numbers ..... F-5  
    port configurations ..... F-4  
    unpacking..... F-1  
TRANZport 232 installation ..... F-2  
Troubleshooting ..... 3-9  
    display panel ..... 3-9  
    keypad..... 3-10  
    printer ..... 3-9  
    telephone connection..... 3-9  
    terminal transactions..... 3-10

## U

Unpacking terminal ..... 3-1  
Unpacking unit ..... B-3, C-2  
Update Password ..... 5-5

## V

Void transaction ..... 6-9

## Z

ZONTALK Download  
    Parameters ..... E-1

