



Parts Catalog

PTO HORSE Tiller

1902404 ext lever + dog clutch

Models

- 12056 (7 HP Standard)
- 12057 (7 HP Electric)
- 12058 (8 HP Standard)
- 12059 (8 HP Electric)

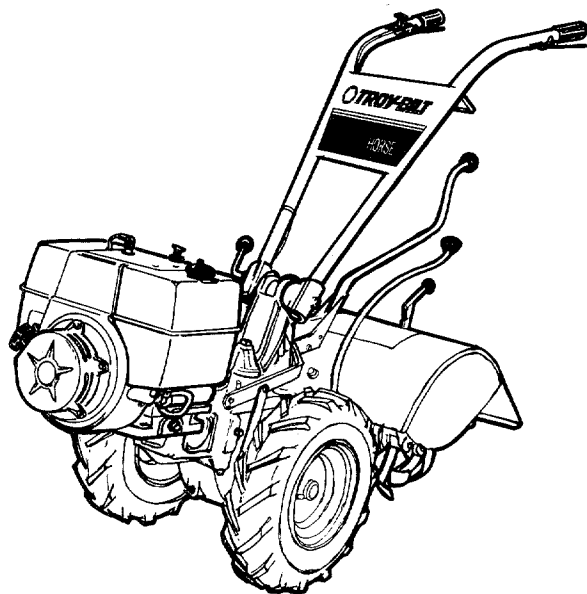

RECORD YOUR TILLER SERIAL NUMBER

If you ever need replacement parts for your tiller, we will need to know your Tiller Serial Number when you write or call us. This number is necessary so that we can correctly identify your machine.

The arrow in the figure at the right points to a location on the top of the transmission housing where the serial number decal is located. For your ready reference, please record this number, along with the delivery date of your tiller, in the spaces provided below.

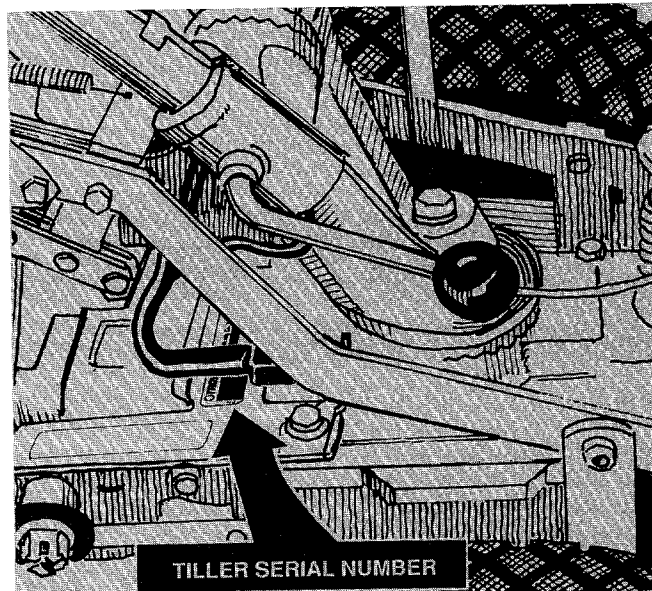

Serial Number: _____

Date of Delivery: _____

TABLE OF CONTENTS

Helpful Information	1
Handlebar Assembly	2
Wheels/Tines/PTO Drive Lever Assembly	3
Wheel Speed Lever, Belt Drive System, Engines & Wheels	4
Depth Regulator & Tine Hood Assemblies	6
Power Unit Transmission	8
Tine Attachment Transmission	12
Bolo Tine Assemblies	14
Forward Interlock System	16
Electric Start System	18
Dozer/Snow Blade Attachment	20
Bumper/Guard Attachment	21
Kickstand Attachment	22
Tine Attachment Cradle	22
Hiller/Furrower Attachment	23
Tow Hitch Attachment	24
Wheel Weights	25
Tire Chains	25
Row Marker Attachment	26
Numerical Index	27

HELPFUL INFORMATION

This Parts Catalog covers only the PTO Horse Model TROY-BILT® Roto Tiller-Power Composter built by TROY-BILT Manufacturing Company. This catalog is part of our policy of "trying to be of genuine service to our customers." Please look it over occasionally . . . we think it will be of help to you.

If you have any questions, please write us or call. We'll gladly give you all the help we can. Thank you.

HOW TO FIND A PART

To find a part, locate the page number of the illustration of the part you seek in the Table of Contents. Note that some parts may be shown on more than one illustration because they are also used with other assemblies on your tiller.

Each illustrated part has a REF. NO. right next to it. This REF. NO. also appears in the first column of the parts list that accompanies the illustration.

The second column of the parts list shows the PART NO. given to that particular part. USE THIS PART NO. TO ORDER THE PART.

Under the DESCRIPTION column, the capitalized words show the name of the part or assembly. Additional descriptive information is often given to help identify the location or function of the part.

The fourth column shows how many (QTY.) of each part is used in the illustration. If a part is used more than once on the tiller, you can determine how many times and where on the tiller by looking at the Numerical Index of parts in the back of this catalog. This index shows the page and Ref. No. of all the parts. Thus, if you know the part number, but do not know its name, location, or use, the Index refers you to the proper page and reference number.

The fifth column shows whether or not a part REPLACES an earlier part number. Sometimes it reflects a simple number change, or an improvement in design or materials. In these instances, the parts are interchangeable, unless otherwise noted in the Description column.

HOW TO ORDER PARTS

Parts for your tiller may be ordered from your local servicing dealer or directly from us (see factory address and telephone information on back cover). When ordering parts the following information is required:

1. The Model Name and Serial Number of your tiller.
2. The Model Name and Horsepower rating of your engine.
3. The Part Number of the part you need.
4. The Part Description.
5. The Quantity needed.

Pre-payment for parts may not be necessary unless the total order reaches a certain amount. Details on our payment plan and current pricing will be gladly furnished upon request.

IMPORTANT: All engine parts should be ordered from your local authorized engine dealer as we do not stock engine parts. Look in the Yellow Pages of your telephone directory under "Engines-Gasoline" for the name of your nearest service dealer. If you have any difficulty in finding an authorized service dealer, please contact our Technical Service Department for assistance.

PLEASE NOTE

Some replacement parts may vary slightly in shape, color, or texture from the original parts. This is because certain parts are supplied to us by more than one manufacturer. Please be assured, however, that all parts must conform to our rigid quality specifications, and any slight variations will not affect the fit or performance of these parts in your tiller.

EXPLANATION OF "LEFT SIDE" AND "RIGHT SIDE"

Left and Right sides of the tiller are determined by standing in the operator position and facing in the direction of forward travel.

HANDLEBAR ASSEMBLY

(Figure 1)

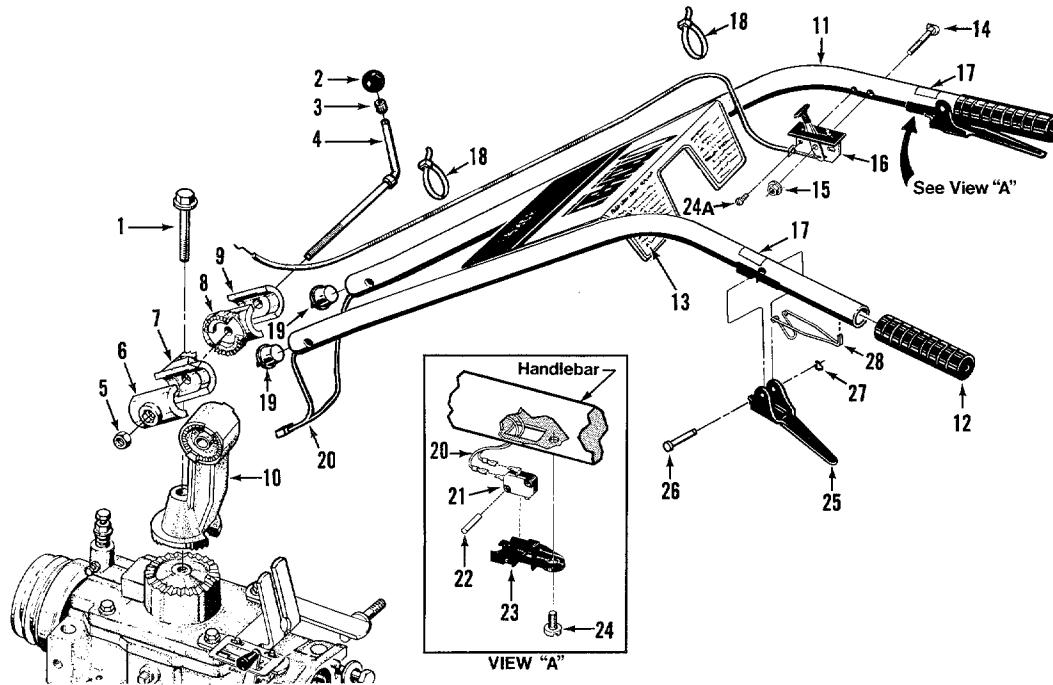

REF. NO.	PART NO.	DESCRIPTION	QTY.	RE-PLACES
HANDLEBAR ASSEMBLY				
1	9548	BOLT — hex head, flanged self-locking (Grade 5), 1/2"-13 x 3-1/2"	1
2	9119	KNOB — handlebar height adjustment. Includes Ref. No. 3	1
3	9120	RING — retaining (tolerance ring)	1
4	1881	STUD — handlebar height adjustment. Includes Ref. Nos. 2, 3 & 5	1
5	9803	NUT — hex., 1/2"-13	1
6	1900854010	CLAMP — left, handlebar height adjustment	1
7	1900856010	RATCHET — left, handlebar height adjustment	1
8	1900857010	RATCHET — right, handlebar height adjustment	1
9	1900855010	CLAMP — right, handlebar height adjustment	1
10	1900858010	BASE — handlebar mounting	1
11	2704	HANDLEBARS — Includes two each of Ref. Nos. 12, 17 & 28, and one Ref. No. 13	1
12	9125	GRIP — handlebars	2
13	2715	DECAL — operator control panel	1
14	9547	BOLT — curved head (Grade 5), 1/4"-20 x 2"	1
15	9844	NUT — hex, flanged self-locking, 1/4"-20 (Whiz Lock)	1
16	9444	THROTTLE CONTROL & CABLE — for Briggs & Stratton Engine only. Also see Ref. No. 24A.	1
16A	9650	THROTTLE CONTROL & CABLE — for 8HP Kohler Engine only	1
17	1900763	DECAL — Forward Interlock Lever	2
18	9202	TIE — plastic	2
19	9219	PLUG — wire harness retainer	2
20	2551	HANDLEBAR WIRE HARNESS ASSEMBLY — Forward Interlock System	1
21	9250	HANDLEBAR SWITCH — Forward Interlock System	2
22	9385	LOCK PIN — handlebar switch	2
23	2543	SWITCH HOUSING — handlebar switch	2
24	90039	SCREW — pan head, #10-24 x 1/2", thread forming	2
24A	9733	SCREW — Phillips Head, #10-32 x 1/2" thread forming	1
25	2546	LEVER — Forward Interlock	2
26	9199	PIVOT PIN — Forward Interlock Lever	2
27	9514	RETAINING RING (Klip Ring) — Forward Interlock Lever	2
28	9387	RETURN SPRING — Forward Interlock Lever	2

WHEELS/TINES/PTO DRIVE LEVER & YOKE ASSEMBLY

(Figure 2)

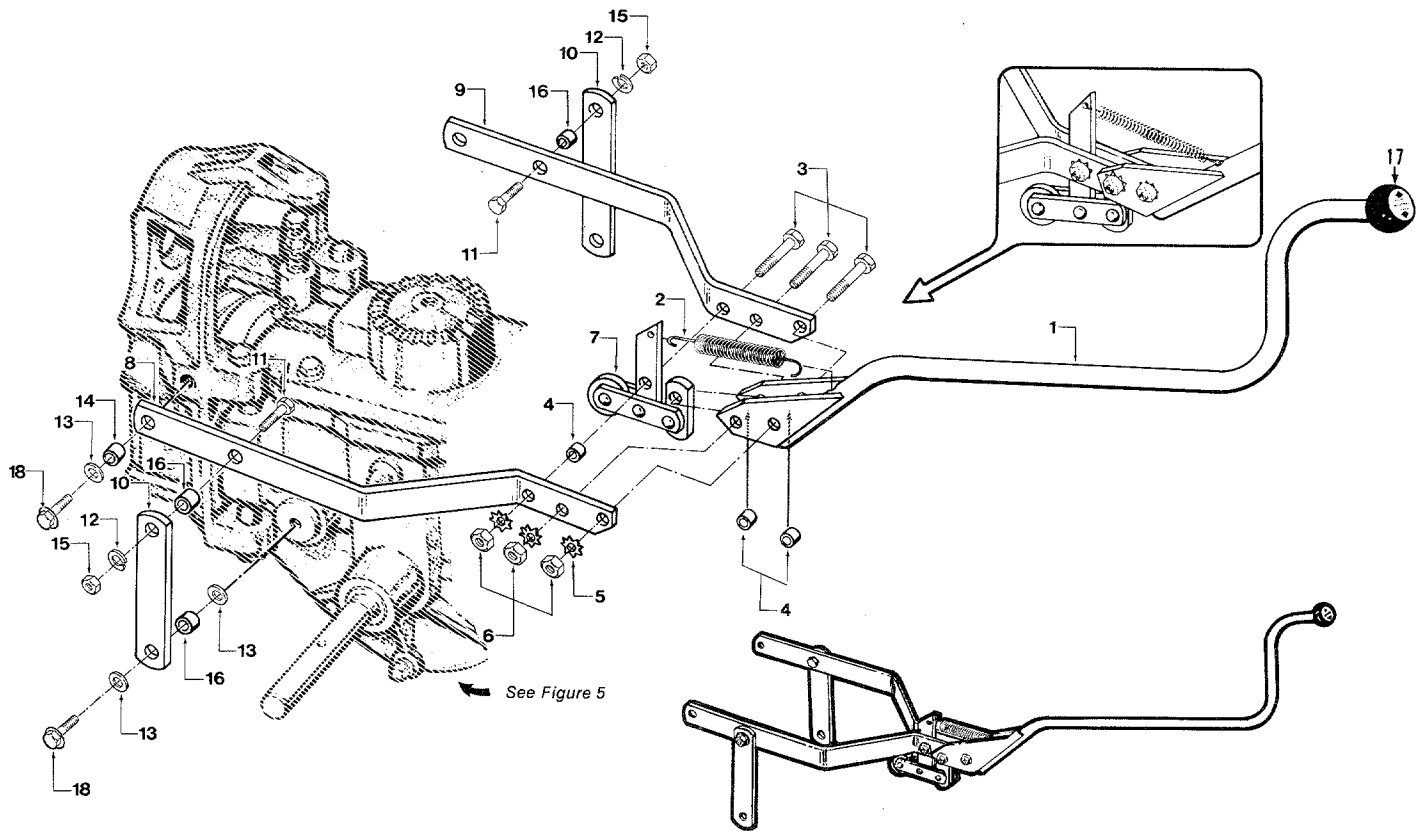

REF. NO.	PART NO.	DESCRIPTION	QTY.	RE-PLACES
1	2574	LEVER — Wheels/Tines/PTO Drive. Includes plastic knob with plastic decal inlay. Lever and knob available as complete assembly only	1
2	2163	SPRING — clutch pawl	1
3	9466	BOLT — hex. hd., 5/16"-18 x 1-1/2"	3
4	2447	BUSHING — 3/8" long	3	2160
5	9919	LOCKWASHER — external tooth, 5/16"	3
6	9801	NUT — hex., 5/16"-18	3
7	2232	ROLLER ASSEMBLY	3
8	1900468010	YOKE — left side	1
9	1900469010	YOKE — right side	1
10	1900860010	LINK — yoke pivot, left and right, 6-7/8" long	1
11	9710	BOLT — hex. hd., 3/8"-16 x 1"	2
12	9913	LOCKWASHER — spring lock, 3/8"	2
13	9904	WASHER — flat, 3/8", S.A.E.	2
14	2146	BUSHING — spacer, 21/64" (.325") long, yoke to engine mount	6
15	9802	NUT — hex., 3/8"-16	2
16	1113-1	BUSHING — spacer, 19/64" (.300") long, yoke link	4
17	---	KNOB — plastic knob not available separately due to special procedure required to attach knob to lever
18	90046	BOLT — flanged hex. hd., 3/8"-16 x 1"	4

WHEEL SPEED LEVER, BELT DRIVE SYSTEM, ENGINES, WHEELS

(Figure 3)

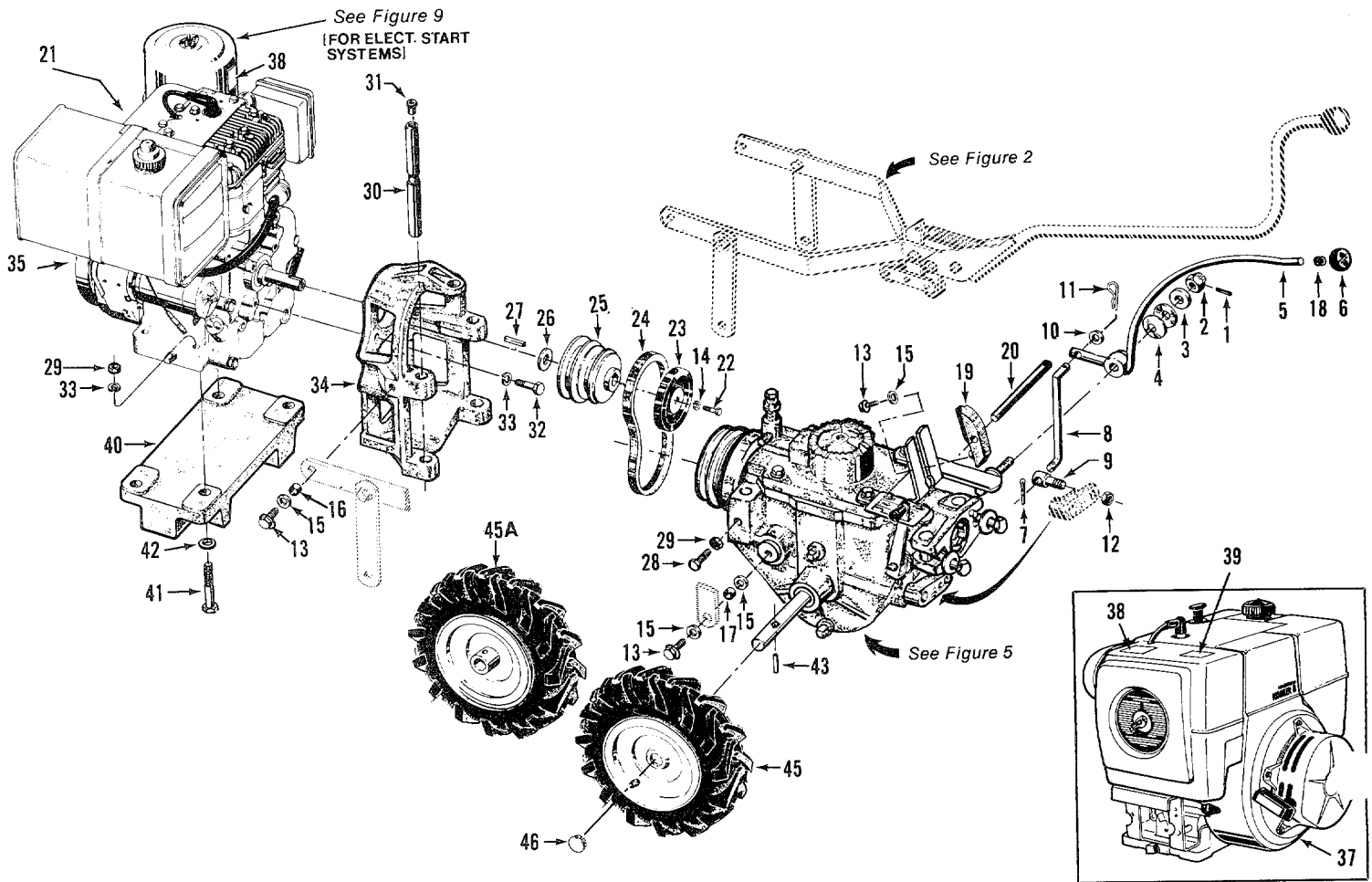

REF. NO.	PART NO.	DESCRIPTION	QTY.	RE-PLACES
WHEEL SPEED LEVER				
1	9362	PIN — spring, 1/8" dia., retains castle nut to threaded stud	1
2	9838	NUT—castle (slotted), 1/2"-20. Call Technical Service Department for tightening instructions	1
3	9934	WASHER — shoulder, 1/2" (shoulder faces disc washers)	1
4	9932	WASHER — disc spring (concave surfaces face each other)	2
5	2628	LEVER — wheel speed shift. Includes #2596 knob (Ref. #6) and #9120 retaining ring (Ref. #18)	1
6	2596	KNOB — wheel speed shift lever. Includes #9120 retaining ring (Ref. #18) and plastic decal inlay	1
7	9317	PIN — cotter, 3/32" x 1"	1
8	1231	ROD — connecting rod, wheel speed shift lever	1
9	1033	SWIVEL — connecting rod	1
10	9902	WASHER — flat, 5/16", S.A.E.	1
11	9338	PIN — hair cotter	1	9317
12	9808	LOCKNUT — hex. hd., 5/16"-18, retains swivel to eccentric lever	1
13	90046	BOLT — flanged hex. hd., 3/8"-16 x 1"	5
14	9913	LOCKWASHER — spring lock, 3/8"	1
15	9904	WASHER — flat, 3/8", S.A.E.	7	9903
16	2146	BUSHING — spacer, 21/64" (.325") long, yoke to engine mount	2
17	1113-1	BUSHING — spacer, 19/64" (.300") long, yoke link to retaining plug	2
18	9120	RING — retaining (tolerance ring)	1

REF. NO.	PART NO.	DESCRIPTION	QTY.	RE-PLACES
----------	----------	-------------	------	-----------

BELT DRIVE SYSTEM

19	1920	BLOCK — belt adjustment, 3-7/8" long. Includes mounting hardware and belt adjustment rod (Ref. #'s 13, 15, & 20)	1
20	2100	ROD — belt adjustment, 7" long, with measuring gauge	1
21	1900766	DECAL — engine stabilization. For Briggs and Stratton engine	1
22	9715	BOLT — hex. hd., 3/8"-24 x 1-1/2", engine pulley mounting	1
23	1919	DISC — reverse, rubber rimmed. Includes #1920 belt adjustment block (Ref. #19)	1
24	9245	BELT — forward drive. Single "V" belt, made specially for your tiller (no substitute recommended due to extra strength required)	1
25	1483	PULLEY — engine P.T.O. (Power Take Off)	1
26	1138-1	SHIM — engine pulley, 1/16" thick	As Req'd.
26	1138-2	SHIM — same as above, 1/32" thick	As Req'd.
27	9303	KEY — engine pulley, 3/16" square x 2-1/2"	1

ENGINES AND ENGINE MOUNT

28	90008	BOLT — hex. hd., 5/16"-18 x 1". Grade 5 specification	2
29	9801	NUT — hex., 5/16"-18	4
30	1034	BAR — engine mounting	2
31	9147	PLUG — thread protector, red plastic	2
32	9572	BOLT — hex. hd., 5/16"-24 x 1-1/8", engine mounting	4
33	9912	LOCKWASHER — spring lock, 5/16"	6
34	2565	MOUNT — engine to tiller.	1
35	1901084	7 HP BRIGGS & STRATTON ENGINE — recoil start. Model No. 171432, Type No. 0529. Industrial/Commercial rated, solid state electronic ignition, horizontal crankshaft is turned down to 3/4" at PTO end to accept engine pulley. See NOTE 1 below	1
35	1901085	7 HP BRIGGS & STRATTON ENGINE — electric start. Model No. 171437, Type No. 0530. Same as engine above, but with electric starting. For use with tillers already equipped with the Key Switch Starting System (see Page 18). See NOTE 1 below	1
37	1901086	8 HP KOHLER MAGNUM ENGINE — recoil start. Model No. M8T. Specification No. PS-301608. Solid state electronic ignition, horizontal crankshaft is turned down to 3/4" at PTO end to accept engine pulley. See NOTE 1 below	1
37	1901087	8 HP KOHLER MAGNUM ENGINE — electric start. Model No. M8ST. Specification No. PS-301609. Same as engine above, but with electric starting. For use with tillers already equipped with the Key Switch Starting System (see Page 18). See NOTE 1 below	1
38	55053	DECAL — hot surfaces safety warning	2
39	1900767	DECAL — engine stabilization. For Kohler engine	1
40	2522	ENGINE WEIGHT — for Briggs & Stratton engine only	1
41	9966	BOLT — Hex hd., 5/16"-18 x 2-1/4". Grade 5 specification	2
42	20553	SPACER — zinc plated	2

WHEEL & TIRE ASSEMBLIES

43	9322	PIN — roll (spiro), 5/16" x 1-1/2" long, wheel hub to shaft	2
45	2709-01	WHEEL & TIRE ASSEMBLY — bar tread, LEFT SIDE. 4:80 x 8" tubeless tire with valve stem, mounted on single-piece steel wheel	1
45A	2709-02	WHEEL & TIRE ASSEMBLY — bar tread, RIGHT SIDE. Same as 2709-01 but for right side of tiller	1
46	9145	CAP — wheel hub	2

NOTE 1 — Please call or write Technical Service Dept. (at Tiller Factory) before ordering replacement engine.

NOTE 2 — For correct traction and directional control, Bar Tread Tires should be mounted on the tiller so that the closed end of the "V" in the tire tread on top of the tire will face forward.

DEPTH REGULATOR & TINE HOOD ASSEMBLIES

(Figure 4)

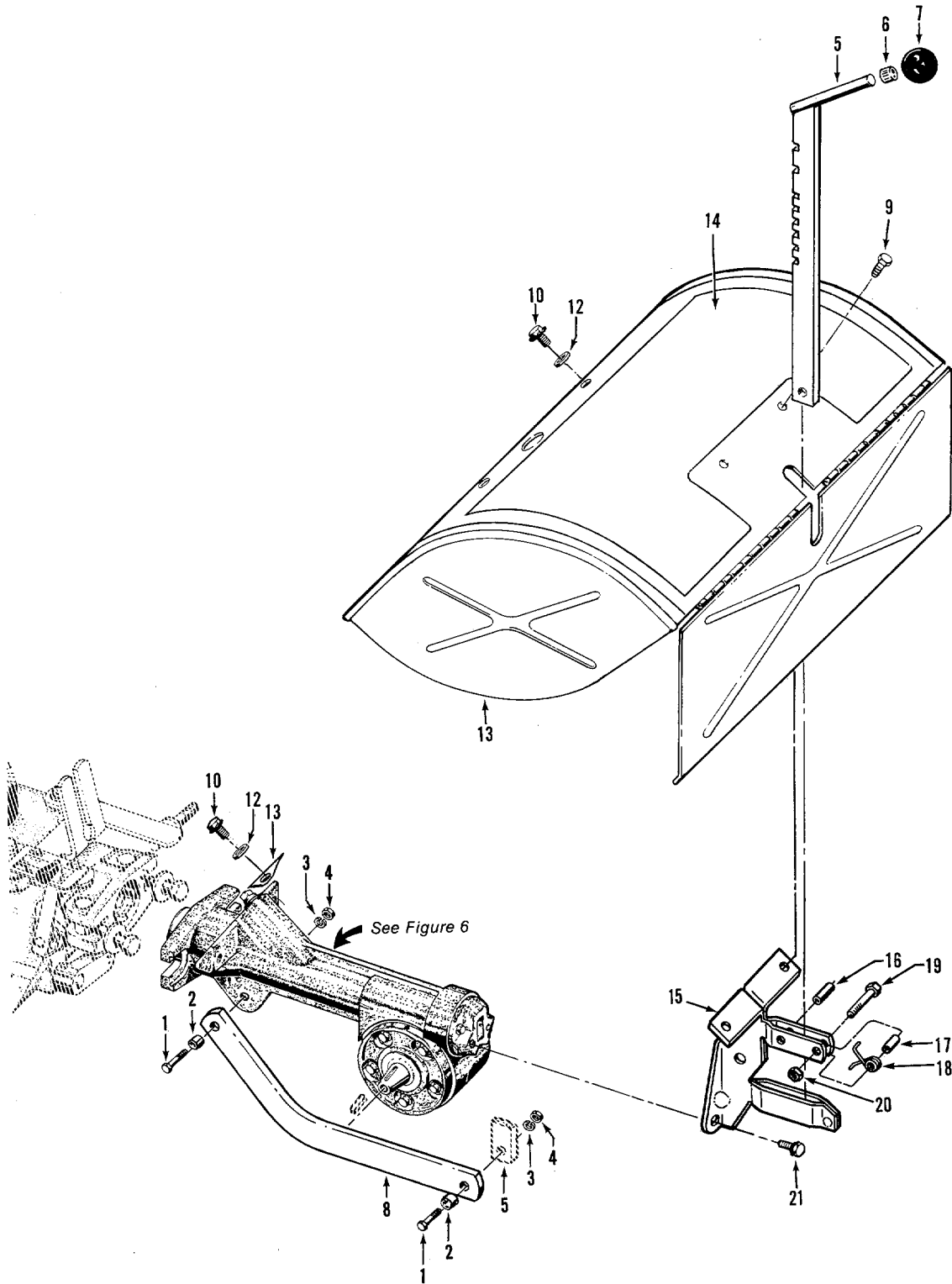

DEPTH REGULATOR & TINE HOOD ASSEMBLIES

(Figure 4)

REF. NO.	PART NO.	DESCRIPTION	QTY.	RE- PLACES
1	9712	BOLT — hex. hd., 3/8"-16 x 1-1/4", drag bar mounting	2
2	1113-1	BUSHING — 19/64" (.300") long, drag bar	2
3	9913	LOCKWASHER — spring lock, 3/8"	2
4	9802	NUT — hex., 3/8"-16	2
5	1117A	BAR — depth regulator. Includes #9119 knob (Ref. #7) and #9120 retaining ring (Ref. #6)	1
6	9120	RING — retaining (tolerance ring)	1
7	9119	KNOB — depth regulator. Includes #9120 retaining ring (Ref. #6)	1
8	1900867010	BAR — drag, depth regulator	1
9	9552	SCREW — thread forming, 1/4"-20 x 1/2", (lockwasher and nut not required). Mounts hood to bracket	2
10	90044	BOLT — flanged hex. hd., 5/16"-18x3/4", hood to tiller housing	2
11	—	This REF. NO. not used
12	9929	WASHER — flat, 5/16"	2
13	2629	HOOD — tine cover with hinged flap. Includes hood decal (Ref. # 14)	1
14	2719	DECAL — hood, operating instructions	1
15	2527	BRACKET — tine hood and depth regulator. Includes roll pin (Ref. #16)	1
16	9308	PIN — roll (spirol), 1/4" x 1" long	1
17	9534	SPACER	1
18	9384	SPRING	1
19	9734	BOLT — hex hd., 1/4"-20 x 1"	1
20	9811	LOCKNUT — 1/4"-20	1
1	90038	BOLT — flanged hex. hd., 5/16"-18 x 5/8", hood bracket to rear bearing cap	2

POWER UNIT TRANSMISSION ASSEMBLIES

(Figure 5)

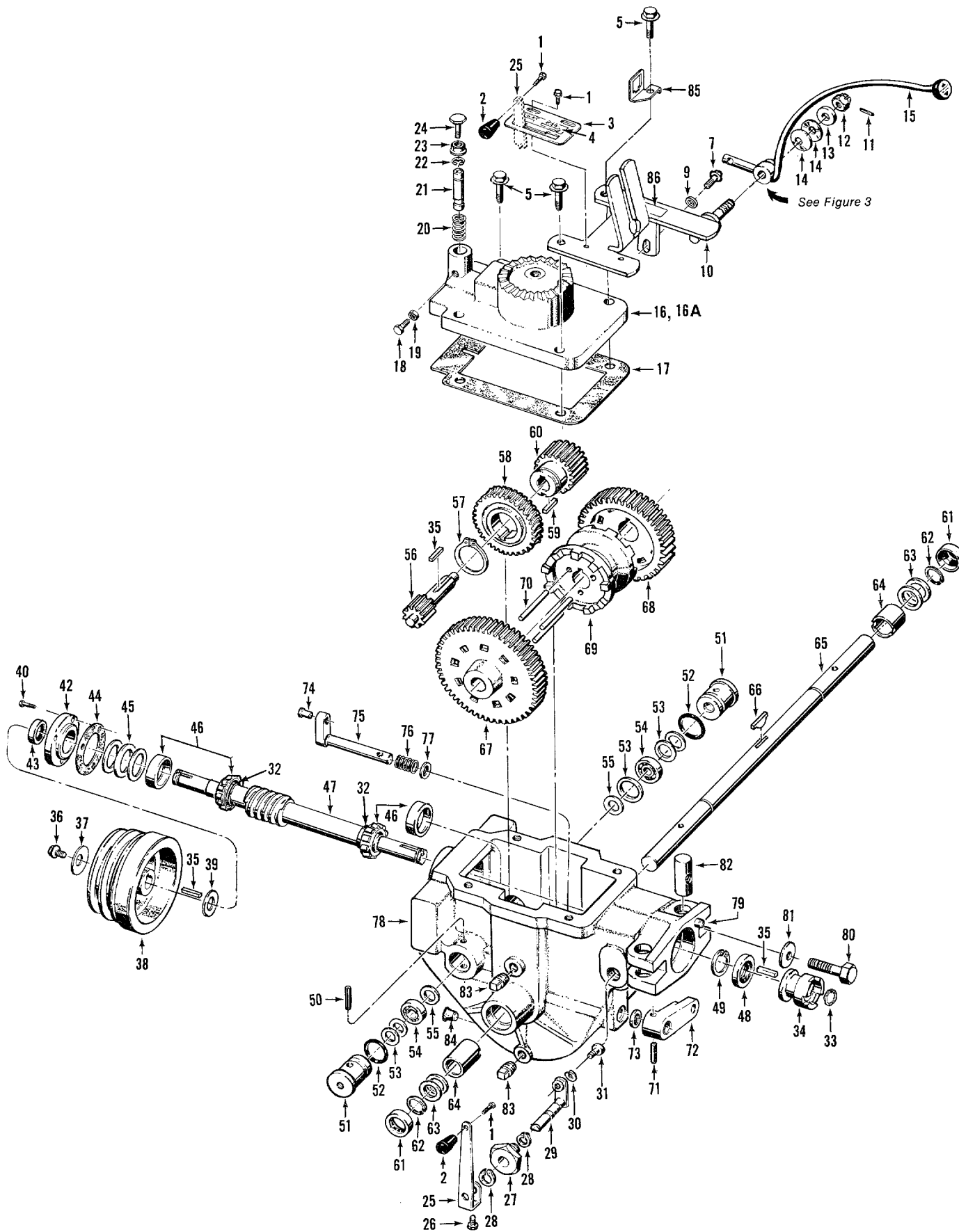

POWER UNIT TRANSMISSION ASSEMBLIES

(Figure 5)

REF. NO.	PART NO.	DESCRIPTION	QTY.	RE-PLACES
TRANSMISSION COVER & SHIFT LEVER BRACKET ASSEMBLIES				
1	9782	BOLT — hex. hd., #10-32 x 3/8", self locking flange	3
2	9463	KNOB — tines/PTO clutch lever, tapered, plastic	1
3	2263	DETENT PLATE — tines/PTO clutch lever. Includes #1900758 operating decal (Ref. #4)	1
4	1900758	DECAL — operating instructions, detent plate	1
5	90047	BOLT — flanged hex. hd., 3/8"-16 x 1-1/2", transmission cover	4
6	—	This REF. NO. not used
7	90044	BOLT — flanged hex. hd., 5/16"-18 x 3/4", Grade 5, lever bracket to housing	1
8	—	This REF. NO. not used
9	9902	WASHER — flat, 5/16", S.A.E.	1
10	1900870010	BRACKET — shift levers. See Ref. No. 86 for decal	1
11	9362	PIN — spring, 1/8" diameter	1
12	9838	NUT—castle (slotted), 1/2"-20. Call Technical Service Department for tightening instructions	1
13	9934	WASHER — shoulder, 1/2" (shoulder faces disc washers)	1
14	9932	WASHER — disc spring (concave surfaces face each other)	2
15	—	LEVER — wheel speed shift. Shown for reference only. See Page 4 (Ref. #5) for part number and description	1
16	1900869010	COVER — power unit transmission housing	1
.6A	2566	COVER — power unit transmission housing. Completely assembled with neutral spring assembly parts (Ref. #'s 18, 19, 20, 21, 22, 23 and 24)	1
17	1123	GASKET — transmission cover	1
18	90008	BOLT — hex. hd., 5/16"-18 x 1", Grade 5. Retains neutral plunger (REMOVE WITH CARE). See Ref. #'s 20 & 21	1
19	9801	NUT — hex., 5/16"-18	1
20	1901439	SPRING — neutral plunger (REMOVE WITH CARE)	1
21	1035	PLUNGER — neutral (REMOVE WITH CARE). Includes #1901440 clip ring (Ref. #22)	1
22	1901440	CLIP RING — retains neutral plunger	1
23	9831	NUT — hex., flange locknut, 3/8"-16	1
24	9545	BOLT — hex. hd., 3/8"-16 x 1-1/2", threaded full length	1
TINES/PTO CLUTCH LEVER ASSEMBLY				
25	1900878010	LEVER — eccentric, tines/PTO clutch. (Also see Ref. #'s 1, 2, 3 and 4 listed above.)	1
26	9743	BOLT — hex. hd., 1/4"-20 x 1/2"	1
27	2123	BUSHING — tines/PTO clutch lever eccentric shaft	1
28	9516	RETAINING RING — (snap ring), external	2
29	2461	ECCENTRIC — shaft, tines/PTO clutch lever	1
30	9911	LOCKWASHER — Hi-collar, 1/4"	1
31	9672	SCREW — socket hd., 1/4"-20 x 3/8"	1
DRIVE SHAFT ASSEMBLY				
32	1138-1	WASHER — shoulder (drive shaft)	2
33	9500	RETAINING RING — (snap ring), external. Retains dog clutch to drive shaft	1
4	2120-3	DOG CLUTCH — power unit	1
35	9301	KEY — 3/16" square x 1" (used on drive shaft and pinion shaft)	3
36	9655	BOLT — hex. hd., 5/16"-24 x 3/4", self-locking flange, Grade 5	1	9799
37	9944	WASHER — disc spring (concave). Domed side of washer faces bolt head	1
38	2107	PULLEY — transmission drive, cast iron	1

(continued)

POWER UNIT TRANSMISSION ASSEMBLIES

(Figure 5)

REF. NO.	PART NO.	DESCRIPTION	QTY.	RE-PLACES
(continued)				
39	50027	WASHER — flat, hardened shoulder, 1-1/4"	1
40	9579	BOLT — hex. hd., 1/4"-20 x 3/4", front bearing cap	3
41	—	This REF. NO. not used
42	1900879010	CAP — front bearing	1	1114
43	85030	SEAL — oil, front bearing cap	1
44	1124-2	GASKET — front bearing cap	1
45	1224-1	SHIM — front bearing cap, .010" thick	As Req'd.
45	1224-2	SHIM — same as above, .030" thick	As Req'd.
45	1224-3	SHIM — same as above, .005" thick	As Req'd.
45	1224-4	SHIM — same as above, .062" thick	As Req'd.
46	1714	BEARING & CUP — tapered cone roller bearing with cup (race). Cone and cup sold as set only	2
47	11601	SHAFT — main drive, power unit. Includes an integral worm, plus two pressed-on cone roller bearings, two bearing cups, and two shoulder washers . .	1
48	9617	SEAL — oil, drive shaft, rear	1
49	9517	RETAINING RING — (snap ring), internal. Retains rear bearing cup	1
PINION SHAFT ASSEMBLY				
50	9309	PIN — roll (spiral), 1/4" x 2", retains #1060A plug (Ref. #51)	2
51	1060A	PLUG — retaining, pinion bearing. Includes #9604 O-Ring (Ref. #52)	2
52	9604	O-RING — retaining plug	2
53	1132-1	SHIM — retaining plug, 1-1/64" inner dia., .033" thick. Note: On right side only, one #1132-1 shim is also used between bearing and washer (Ref. #'s 54 & 55)	As Req'd.
53	1132-2	SHIM — same as above, .062" thick	As Req'd.
53	1132-3	SHIM — same as above, .010" thick	As Req'd.
54	9404	BEARING — ball, pinion shaft	2
55	1126	WASHER — pinion shaft. One used on left and right sides	2
56	1222	STEM PINION — slow speed gear and shaft (drives slow speed wheel gear)	1
57	9502	RETAINING RING — (snap ring), external. Retains high speed pinion gear to bronze worm gear	1
58	2656	WORM GEAR — bronze, wheel drive. Driven by worm on drive shaft	1
59	9300	KEY — 3/16" square x 5/8". Connects fast speed pinion gear to bronze worm gear .	1
60	1233	GEAR — fast speed pinion (drives fast speed wheel gear)	1
WHEEL SHAFT ASSEMBLY				
61	9621	SEAL — oil, wheel shaft	2	9609
62	9511	RETAINING RING — (snap ring), external. Retains wheel shaft inside bore	2
63	1166-1	SHIM — wheel shaft, 1-1/64" inner dia., .062" thick	As Req'd.
63	1166-2	SHIM — same as above, .030" thick	As Req'd.
63	1166-3	SHIM — same as above, .015" thick	As Req'd.
63	1166-4	SHIM — same as above, .010" thick	As Req'd.
63	1166-5	SHIM — same as above, .005" thick	As Req'd.

(continued)

POWER UNIT TRANSMISSION ASSEMBLIES

(Figure 5)

REF. NO.	PART NO.	DESCRIPTION	QTY.	RE-PLACES
(continued)				
64	1086	BUSHING — bronze, wheel shaft bearing	2
65	1878	SHAFT — wheel, 15-5/8". Includes #9357 key (Ref. #66) and two #9511 retaining rings (Ref. #62)	1
66	9357	KEY — Hi Pro, 1/4" x 1 3/4". Connects wheel shaft to clutch	1
67	1223	GEAR — slow speed, wheel drive	1
68	1232	GEAR — fast speed, wheel drive	1
69	1237	DOG CLUTCH — wheel drive. Clutch drives either slow or fast wheel drive gears according to wheel speed shift lever gear selection	1
70	1112	PIN — clutch guide, 1/4" diameter	3
ECCENTRIC SHAFT ASSEMBLY				
71	9307	PIN — roll (spirol), 3/16" x 1-1/4". Retains eccentric lever to eccentric shaft	1
72	1900880010	LEVER — eccentric, wheel speed shifting	1
73	9622	SEAL — oil, eccentric shaft	1	9611
74	1442	PIN — eccentric shaft, wheel speed shifting	1
75	2712	ECCENTRIC SHAFT — wheel speed shifting	1
76	1441	SPRING — eccentric shaft	1
77	1440	WASHER — eccentric shaft	1
TRANSMISSION HOUSING				
78	2260	HOUSING — power unit transmission. Includes #9359 alignment pin (Ref. #79). Empty housing without covers, shafts, gears, seals, etc. Call Factory Technical Service Dept. before ordering	1
79	9359	PIN — alignment (aligns power unit housing with tiller attachment housing)	1
MISCELLANEOUS PARTS				
80	9560	BOLT — hex. hd., 1/2"-13 x 2", Grade 5. Connects power unit and tiller attachment housings	2
81	9928	WASHER — disc spring (concave). Domed side of washer faces bolt head	2
82	2126	POST — with threaded hole for #9560 bolt (Ref. #80)	2
83	9726	PLUG — pipe, 1/4". Oil level check plug and oil drain plug	2
84	9122	PLUG — red plastic, thread protector	1
85	9205	CLIP — for Forward Interlock System plug connector (also see Page 16)	1
86	1900759	DECAL — Forward Interlock Wire Harness	1

TILLER ATTACHMENT TRANSMISSION ASSEMBLIES

(Figure 6)

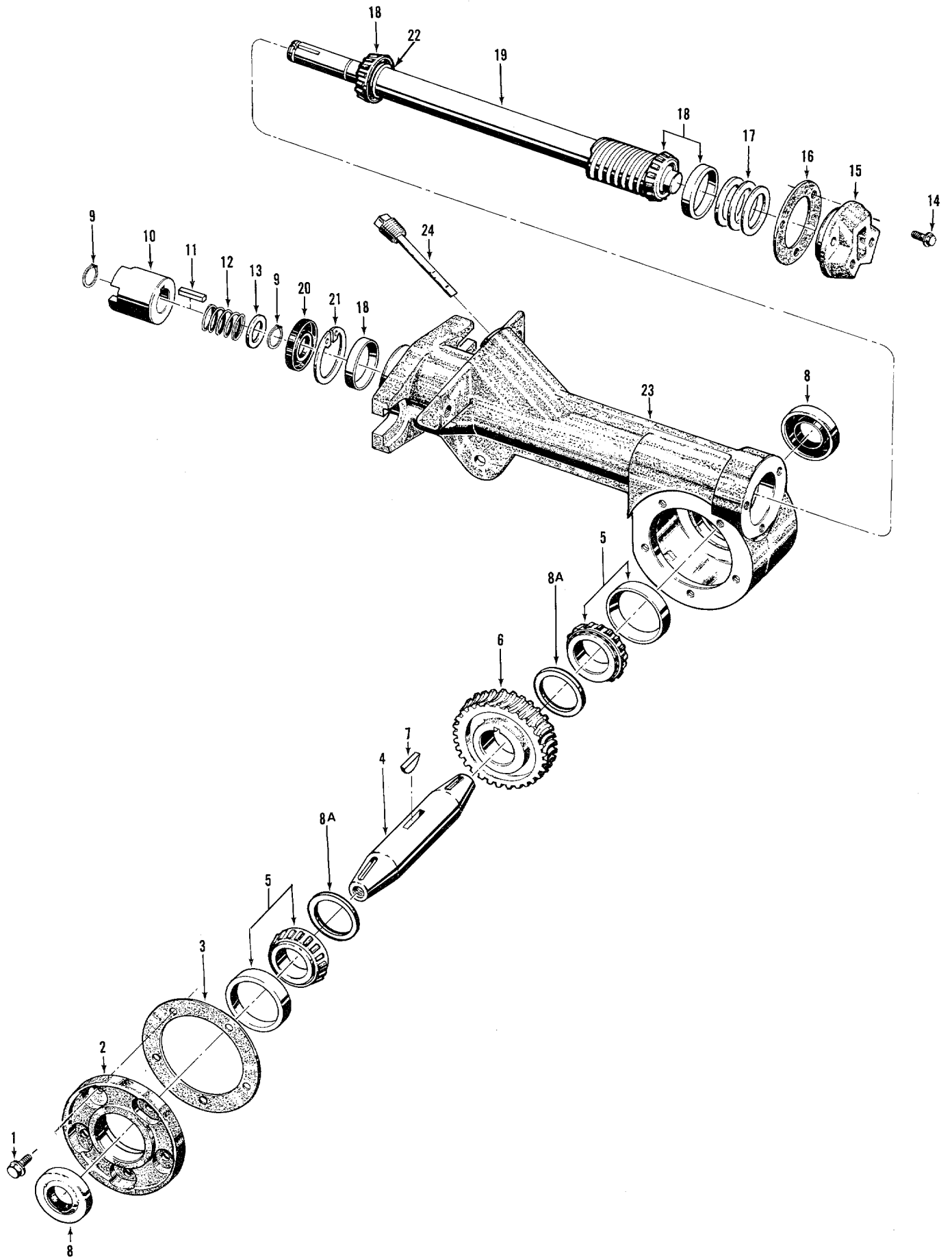

TILLER ATTACHMENT TRANSMISSION ASSEMBLIES

(Figure 6)

REF. NO.	PART NO.	DESCRIPTION	QTY.	RE-PLACES
TILLER TINE SHAFT ASSEMBLY				
1	1908211	BOLT — hex. hd., 1/4"-20 x 5/8", self-locking flange	5
2	2451	COVER — tiller housing.	1	1872
3	1129-1	GASKET — tiller housing cover, .010" thick	As Req'd.
3	1129-2	GASKET — same as above, .030" thick	As Req'd.
4	1026	SHAFT — tiller tine	1
5	11522	BEARING & CUP — tapered cone roller bearing with cup (race). Cone and cup sold as set only	2
6	2654	WORM GEAR — bronze, tiller tine shaft. Driven by worm on tiller drive shaft	1
7	97067	KEY — tiller tine shaft. Woodruff key with ends ground	1
8	9616	SEAL — oil, tiller tine shaft	2
8A	94017	WASHER — special, heat-treated	2
TILLER DRIVE SHAFT ASSEMBLY				
9	9500	RETAINING RING — (snap ring), external. Retains dog clutch to shaft	2
10	2120-1	DOG CLUTCH — tiller drive shaft <i>1.902404 EXT. LEVER + DOG</i>	1	<i>Clutch KIT</i>
11	9301	KEY — 3/16" square x 1", dog clutch to tiller drive shaft	1
12	2127	SPRING — dog clutch	1
13	1138-1	SHIM — dog clutch, 1/16" (.062") thick	1
14	1908212	BOLT — hex. hd., 1/4"-20 x 7/8", self locking flange	3
15	1900881010	CAP — rear bearing	1
16	1124-2	GASKET — rear bearing cap	1
17	1224-1	SHIM — front bearing cap, .010" thick	As Req'd.
17	1224-2	SHIM — same as above, .030" thick	As Req'd.
17	1224-3	SHIM — same as above, .005" thick	As Req'd.
17	1224-4	SHIM — same as above, .062" thick	As Req'd.
18	1714	BEARING & CUP — tapered cone roller bearing with cup (race). Cone and cup sold as set only.	2
19	11602	SHAFT — main tiller drive. Includes an integral worm gear, plus two pressed-on cone roller bearings, two bearing cups (Ref. #18) and one shoulder washer	1
20	9617	SEAL — oil, drive shaft, front	1
21	9517	RETAINING RING — (snap ring), internal. Retains front bearing cup	1
22	1138-1	WASHER — shoulder (drive shaft)	1
TRANSMISSION HOUSING AND DIPSTICK				
23	2206	HOUSING — tiller attachment. Includes pressed-on sleeve in front of housing and one tine shaft bearing cup (Ref. #5) mounted in right side of housing. Empty housing without shafts, gears, seals, dipstick, etc. Call Factory Technical Service Dept. before ordering	1
24	2136	DIPSTICK — oil level, tiller attachment	1

BOLO TINE ASSEMBLIES

(Figure 7)

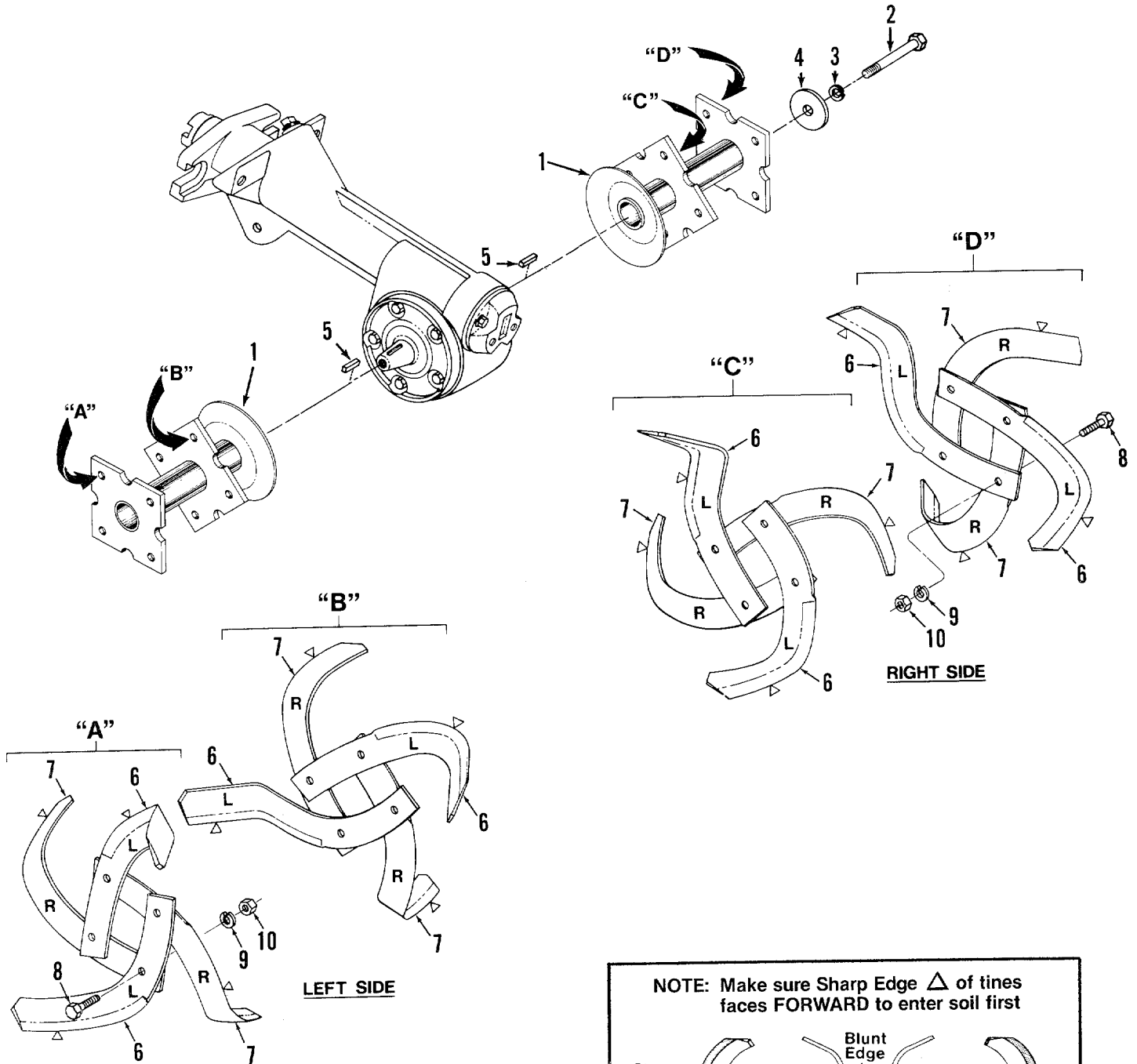

LEGEND:
 △ = Sharp Edge
 L = Left Bolo Tine
 R = Right Bolo Tine

NOTE: Make sure Sharp Edge △ of tines faces FORWARD to enter soil first

Sharp △ Blunt Edge

LEFT HAND TINE RIGHT HAND TINE
 (As viewed with blunt edge facing you.)

BOLO TINE ASSEMBLIES

(Figure 7)

REF. NO.	PART NO.	DESCRIPTION	QTY.	RE-PLACES
1	1900871010	TINE HOLDER — welded steel. For left or right side of tiller	2
2	9669	BOLT — hex hd., 1/2"-20 x 4-3/4" long	2
3	9914	LOCKWASHER — 1/2", holder mounting.	2
4	9952	WASHER — flat. Outer dia. 1.500", inner dia. .516", thickness .182".	2
5	9301	KEY — tine shaft. 3/16" square x 1" long	2
6	1270-1A	BOLO TINE — single, Left Hand. Used on left and right side tine assemblies. Tine is stamped either "EL" or "AL". Includes two each Part #9711 bolts, #9913 lockwashers and #9802 hex nuts	8
7	1270-2A	BOLO TINE — single, Right Hand. Used on left and right side tine assemblies. Tine is stamped either "ER" or "AR". Includes same hardware as described above for left hand tine	8
8	9711	BOLT — hex hd., 3/8"-16 x 1", tine mounting	16
9	9913	LOCKWASHER — 3/8", tine mounting.	16
10	9802	NUT — hex, 3/8"-16, tine mounting.	16
...	1901118	TINE REPLACEMENT KIT — unassembled. Includes eight each of Part #1270-1A and #1270-2A tines and sixteen each of #9711 bolts, #9913 lockwashers and #9802 hex nuts. Includes easy-to-follow instructions for installing tines. DOES NOT INCLUDE tine holders, holder mounting hardware, or tine shaft keys	1
...	10355	WELDED STEEL TINE HOLDER REPLACEMENT KIT — Includes one each of Part #2415 welded steel tine holder, #9669 bolt, #9914 lockwasher and #9952 washer. Order two kits if replacing both holders. DOES NOT INCLUDE tines, tine mounting hardware, or tine shaft key	1

CUSTOM TILLING TINES

Special hard-faced, high chrome carbon alloy tines that are thicker than standard Bolo Tines. These tines better resist the abrasive action of rocky, gritty, or sandy soil as compared to standard Bolo Tines, and are especially suited for custom tilling or market gardening.

...	10802	CUSTOM TILLING TINE KIT — Includes eight each of Part #2475-1 and #2475-2 tines and sixteen each of #9711 bolts and #9807 locknuts	1
...	2475-1	BOLO TINE, CUSTOM TILLING — single, left hand	8
...	2475-2	BOLO TINE, CUSTOM TILLING — single, right hand	8
...	9807	LOCKNUT — Hex, 3/8", used in place of Ref. No.'s 9 and 10 when using Custom Tilling Tines.	16

FORWARD INTERLOCK SYSTEM (Figure 8)

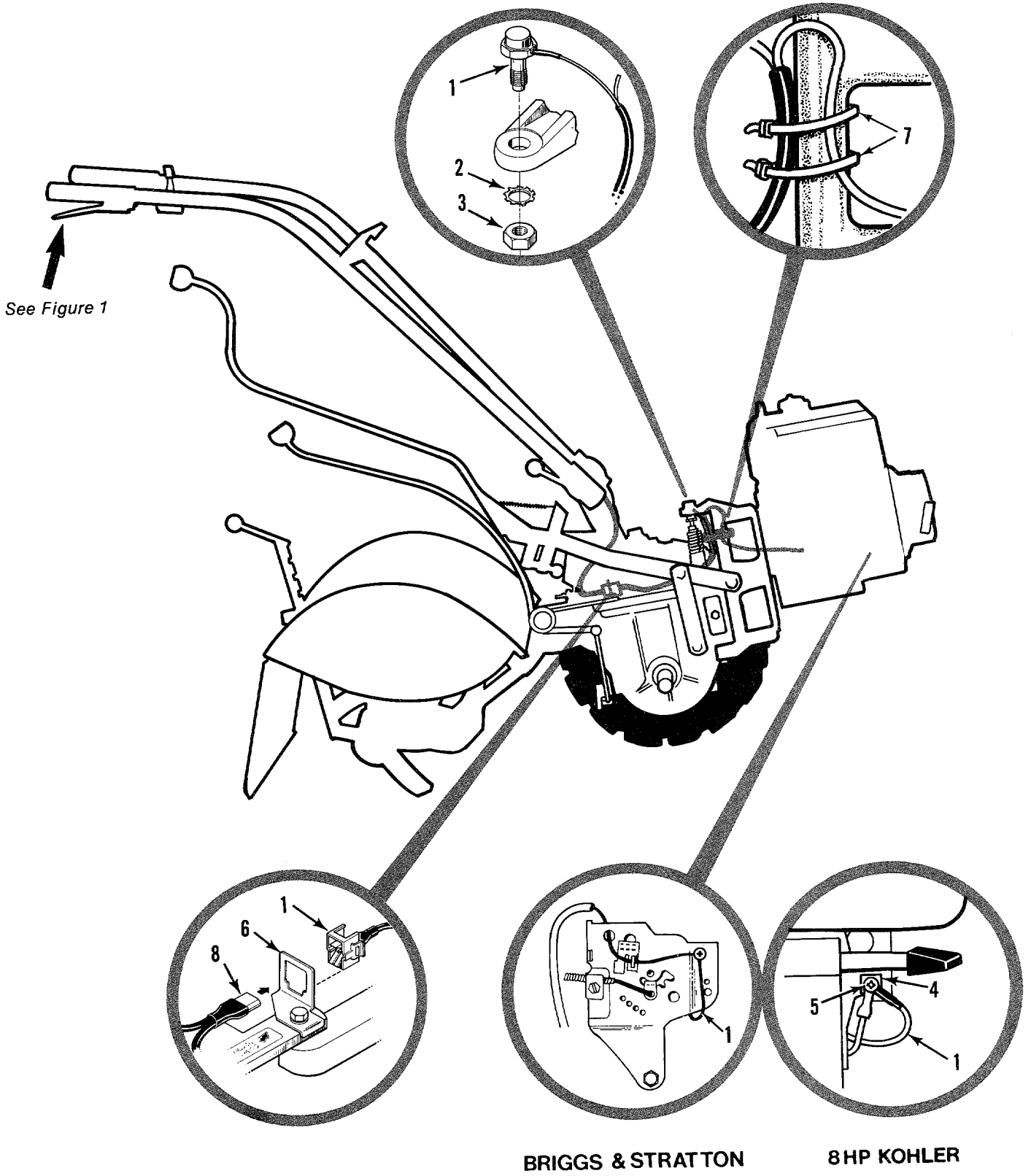

FORWARD INTERLOCK SYSTEM

(Figure 8)

REF. NO.	PART NO.	DESCRIPTION	QTY.	RE- PLACES
1	2552	ENGINE WIRE HARNESS ASSEMBLY — Forward Interlock System. Includes one red and one black wire, plug connector, neutral switch and PVC tubing. Parts not available separately	1
2	9971	LOCKWASHER — external tooth, 7/16"	1
3	9851	NUT — hex., 7/16"-20	1
4	ET69-12	GROMMET — for Kohler engine. NOTE: This part can also be obtained at a Tecumseh Engine Authorized Service Center by ordering Part No. 69-12	1
5	ET42-447	SCREW — #8 Phillips Head. For Kohler engine. NOTE: This part can also be obtained at a Tecumseh Engine Authorized Service Center by ordering Part No. 42-326	1
6	9205	CLIP — for plug connector	1
7	9202	TIE — plastic	1
8	2551	HANDLEBAR WIRE HARNESS ASSEMBLY. (Also see Page 2, Ref. No. 20)	1

ELECTRIC START SYSTEM — 7HP & 8HP TILLERS

(Figure 9)

REF. NO.	PART NO.	DESCRIPTION	QTY.	RE-PLACES
1	96515	CABLE — battery, positive and negative terminals	2
2	97020	RUBBER BOOT — terminal insulating	3
3	9552	SCREW — self threading, 1/4"-20 x 1/2", one for grounding negative cable and two for mounting solenoid to bracket	3
4	9780	BOLT — hex. hd., 1/4"-20 x 5/8"	2	9703
5	1554	WIRE — recharge (red), for Briggs & Stratton engine. Includes terminal and eyelet	1
6	2616	BATTERY HOLD-DOWN CLAMP — with attached Key Switch Plate (includes #1900944 decal)	1
7	1900944	DECAL — key switch instructions	1
8	1908112	KEY SWITCH — includes two #96520 keys, one lockwasher and one mounting nut (hardware not available separately from Garden Way)	1
9	96520	KEY — ignition, one pair	1
10	9566	BOLT — carriage, 1/4"-20 x 1-1/4", hold-down clamp to bracket	2
11	9910	LOCKWASHER — spring lock, 1/4"	2
12	9800	NUT — hex., 1/4"-20	4
13	9092B	BATTERY — 12 volt, 30 amperes, side-vented. Comes with Part #9009 vent tube ..	1
14	96514	SOLENOID — starter. Includes nuts and washers for cables and wires	1	1959
15	9912	LOCKWASHER — spring lock, 5/16", solenoid left and right posts	2
16	9826	NUT — hex., 5/16"-24, solenoid left and right posts	2
17	9921	LOCKWASHER — external tooth, #10, solenoid center post	1
18	9809	NUT — hex., 10-32, center post on solenoid	1
19	96510	CABLE — solenoid to starter motor	1
20	2571	BATTERY BRACKET	1
21	90047	BOLT — flanged hex. hd., 3/8"-16 x 1-1/2", bracket to transmission cover	2
22	—	This REF. NO. not used
23	9265	TIE — twist, red plastic, wire retaining	1
24	9009	VENT TUBE — 5/16" dia.	1
25	1475	SHIELD — vent tube, 1/2" dia.	1
26	9224	CLAMP — vent tube shield	1
27	9202	TIE — plastic	2
28	1908118	WIRE HARNESS — for Briggs & Stratton engine. Includes key switch receptacle with two red wires (with eyelets), one green wire, plastic harness tube. Order red recharging wire (Ref. No. 5) separately, if needed	1
29	1908117	WIRE HARNESS — for Kohler engine. Includes two receptacles; three red wires (solenoid activate, battery recharge, and starter switch); two green (ground) (shutoff) wire; plastic harness tube	1
30	9844	NUT — hex, lock, 1/4"-20	2
31	20421	WIRE — ground	1

DOZER/SNOW BLADE ATTACHMENT

(Figure 10)

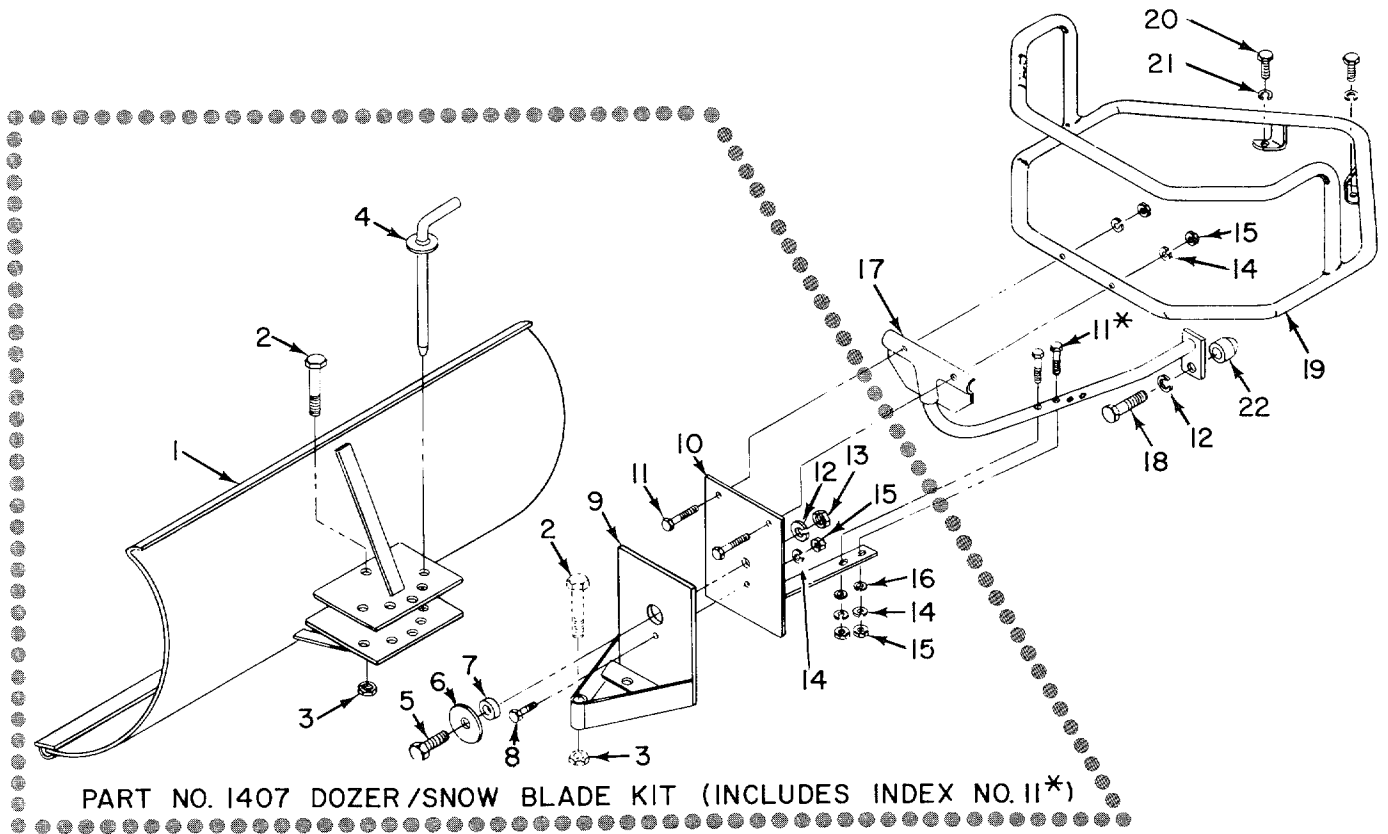

PART NO. 1407 DOZER/SNOW BLADE KIT (INCLUDES INDEX NO. 11*)

REF. NO.	PART NO.	DESCRIPTION	QTY.	RE-PLACES
...	1873	DOZER/SNOW BLADE — complete attachment. Includes Ref. No's. 1 through 22, listed below	1
1	1160	BLADE — dozer/snow blade	1
2	9717	BOLT — hex. head, 1/2"-13 x 3"	1
3	9804	LOCKNUT — hex., 1/2"-13	1
4	1158	PIN — index, blade angle adjustment	1
5	9767	BOLT — hex. head, 1/2"-13 x 1-1/2"	1
6	9905	WASHER — plain, 1/2"	1
7	1416	BUSHING	1
8	9705	BOLT — hex. head, 5/16"-18 x 1-1/4"	1
9	1162	BRACKET — swivel ("A" frame)	1
10	1164	BRACKET — dozer/bumper mounting	1
11	9759	BOLT — hex. head, 5/16"-18 x 1-3/4"	4
12	9914	LOCKWASHER — spring lock, 1/2"	2
13	9803	NUT — hex., 1/2"-13	1
14	9912	LOCKWASHER — spring lock, 5/16"	5
15	9801	NUT — hex., 5/16" x 18	5
16	9902	WASHER — plain, 5/16" S.A.E.	2
17	2659	BRACE — bumper bottom (requires spacer, Part #1561—see Ref. #22, below)	1
18	9716	BOLT — hex. head, 1/2"-13 x 2"	1
19	2658	BUMPER — wraparound	1
20	9710	BOLT — hex. head, 3/8"-16 x 1"	2
21	9913	LOCKWASHER — spring lock, 3/8"	2
22	1561	SPACER — for bottom brace	1
...	1407	DOZER/SNOW BLADE KIT — shown within dotted area in Figure 10. For those who have already purchased a bumper (see Part #1932 on Page 21) and want to add a dozer/snow blade. Kit includes Ref. No's. 1 through 16, shown above	1

BUMPER ATTACHMENT

(Figure 11)

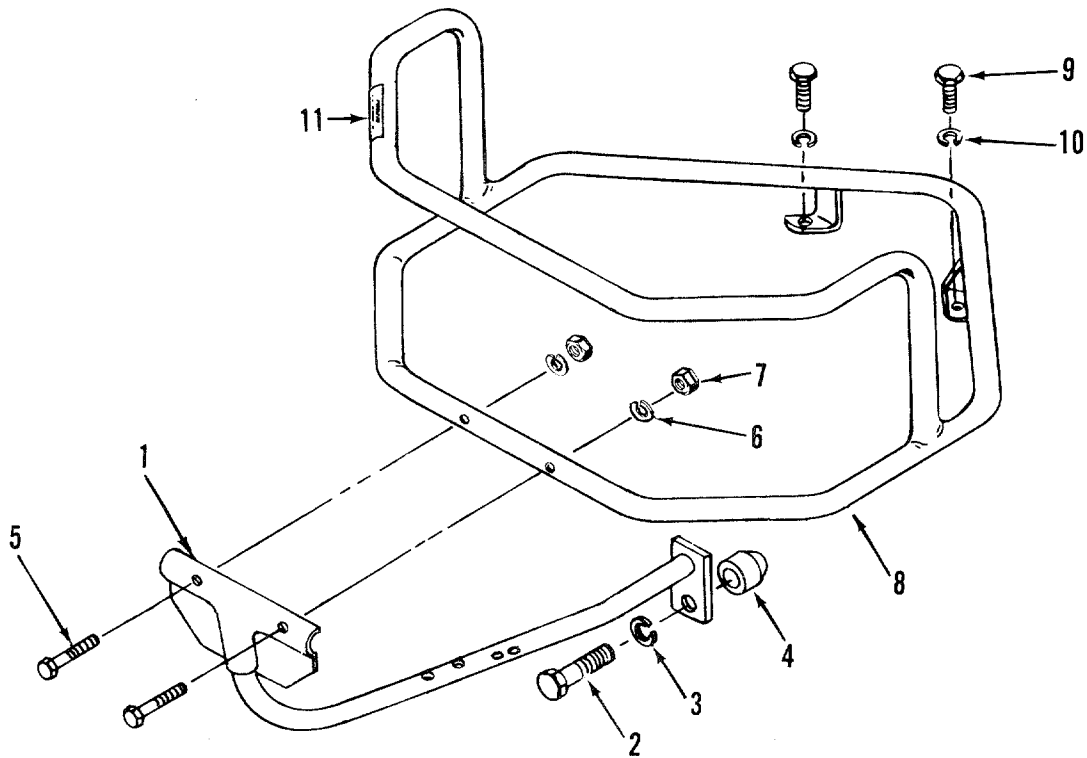

REF. NO.	PART NO.	DESCRIPTION	QTY.	RE-PLACES
...	1932	BUMPER ATTACHMENT — complete. Includes Ref. No's. 1 through 11, listed below	1
1	2659	BRACE — bumper bottom	1
2	9716	BOLT — hex. head, 1/2"-13 x 2"	1
3	9914	LOCKWASHER — spring lock, 1/2"	1
4	1561	SPACER — for bottom brace	1
5	9758	BOLT — hex. head, 5/16"-18 x 1-1/2"	2
6	9912	LOCKWASHER — spring lock, 5/16"	2
7	9801	NUT — hex., 5/16"-18	2
8	2658	BUMPER — wraparound	1
9	9710	BOLT — hex. head, 3/8"-16 x 1"	2
10	9913	LOCKWASHER — spring lock, 3/8"	2
11	1448	DECAL — for bumper	1

KICKSTAND ATTACHMENT

(Figure 12)

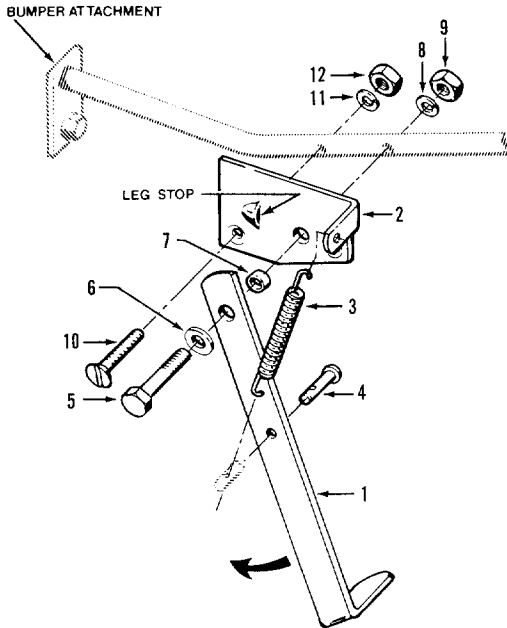

TINE ATTACHMENT CRADLE

(Figure 13)

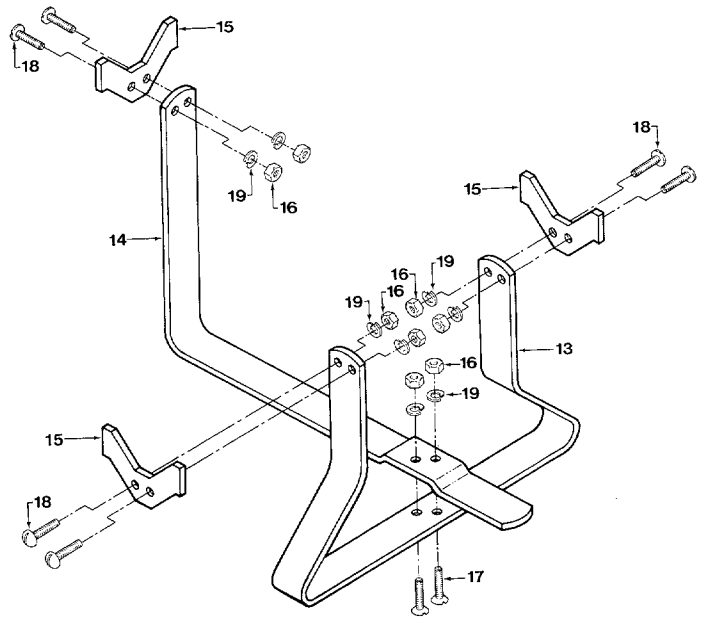

REF. NO.	PART NO.	DESCRIPTION	QTY.	RE-PLACES
KICKSTAND ATTACHMENT				
...	1931	KICKSTAND ATTACHMENT — complete. Includes Ref. No.'s 1 through 12, listed below. Kickstand attaches to lower brace of Bumper Attachment (Part #1932)	1
1	2195	LEG — kickstand	1
2	2196	PLATE — kickstand mounting	1
3	1492	SPRING — kickstand	1
4	9336	PIN — clevis	1
5	9741	BOLT — hex. hd., 5/16" - 18 x 2", Grade 5	1
6	9902	WASHER — flat, 5/16", S.A.E.	1
7	9473	BUSHING — .438" long (.313" O.D., .275" I.D.)	1
8	9912	LOCKWASHER — spring lock, 5/16"	1
9	9801	NUT — hex., 5/16" - 18	1
10	9567	SCREW — flat hd., 1/4" - 20 x 1-1/2"	1
11	9910	LOCKWASHER — spring lock, 1/4"	1
12	9800	NUT — hex., 1/4" - 20	1
TINE ATTACHMENT CRADLE				
...	2007	TINE ATTACHMENT CRADLE — complete. Includes Ref. No.'s 13 through 19, listed below. For storing Tine Attachment when removed from Power Unit. Also assists in removal and replacement of Tine Attachment	1
13	2299	REAR CRADLE SUPPORT	1
14	2301	FRONT CRADLE SUPPORT	1
15	2297	TINE CRADLE PLATE	3
16	9800	NUT — hex., 1/4" - 20	8
17	9580	SCREW — hex hd., 1/4" - 20 x 3/4"	2
18	9701	SCREW — round-head, 1/4" - 20 x 3/4"	6
19	9910	LOCKWASHER — spring lock, 1/4"	8

HILLER/FURROWER ATTACHMENT

(Figure 14)

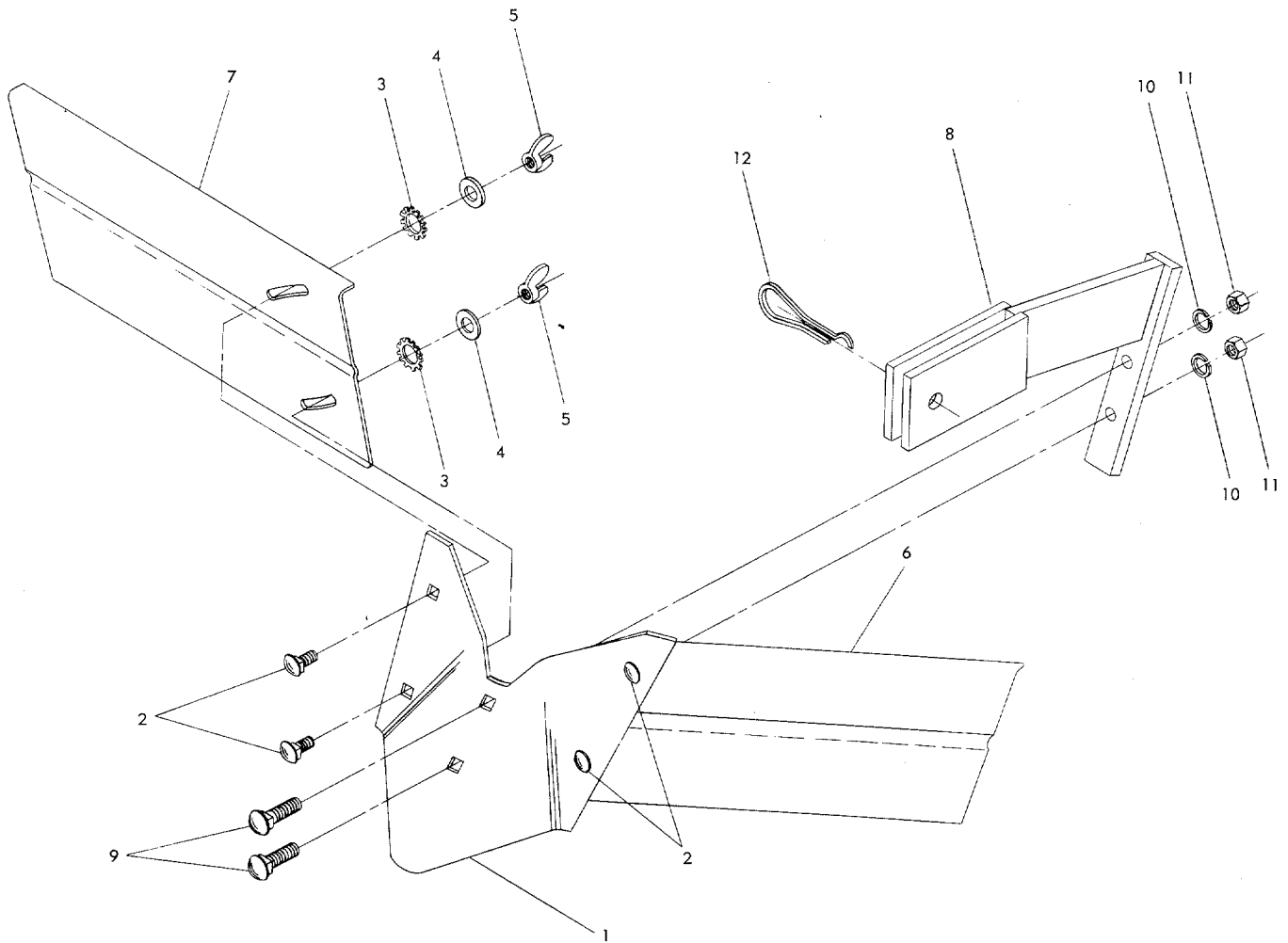

REF. NO.	PART NO.	DESCRIPTION	QTY.	RE-PLACES
...	2638	HILLER/FURROWER — complete attachment (owner must bolt blade to mounting bracket, and wings to blade). Includes Ref. No's 1 through 12, listed below. Instructions included	1
1	2735	FURROWER — blade only	1
2	9765	CARRIAGE BOLT — 5/16"-18 x 3/4"	4
3	9919	STAR WASHER — external tooth, 5/16"	4
4	9902	WASHER — plain, 5/16" S.A.E.	4
5	9824	WING NUT — 5/16"-18	4
6	2736-01	HILLER WING — left	1
7	2736-02	HILLER WING — right	1
8	2636	BRACKET — blade mounting	1
9	9725	CARRIAGE BOLT — blade mounting, 3/8"-16 x 1-1/2"	2
10	9913	LOCKWASHER — spring lock, 3/8", plated	2
11	9802	NUT — hex., 3/8"-16, plated	2
12	9318	PIN — clinch	1

TOW HITCH ATTACHMENT

(Figure 15)

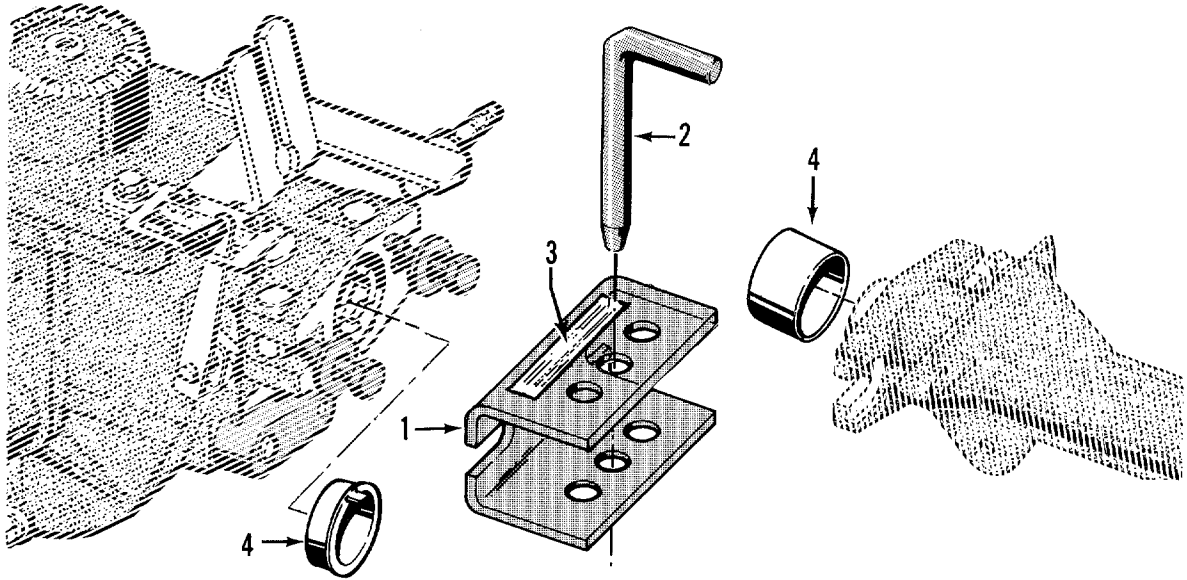

REF. NO.	PART NO.	DESCRIPTION	QTY.	RE-PLACES
...	2004	TOW HITCH ATTACHMENT — complete. Includes Ref. No's 1 through 4, listed below.	1
1	2287	HITCH — mounting plate. Includes decal (Ref. No. 3)	1
2	9363	PIN — hitch	1
3	2288	DECAL — warning instructions	1
4	2006	DUST CAPS — two protective covers, one for transmission PTO access hole and one for dog clutch coupling on tiller attachment	1

WHEEL WEIGHTS

(Figure 16)

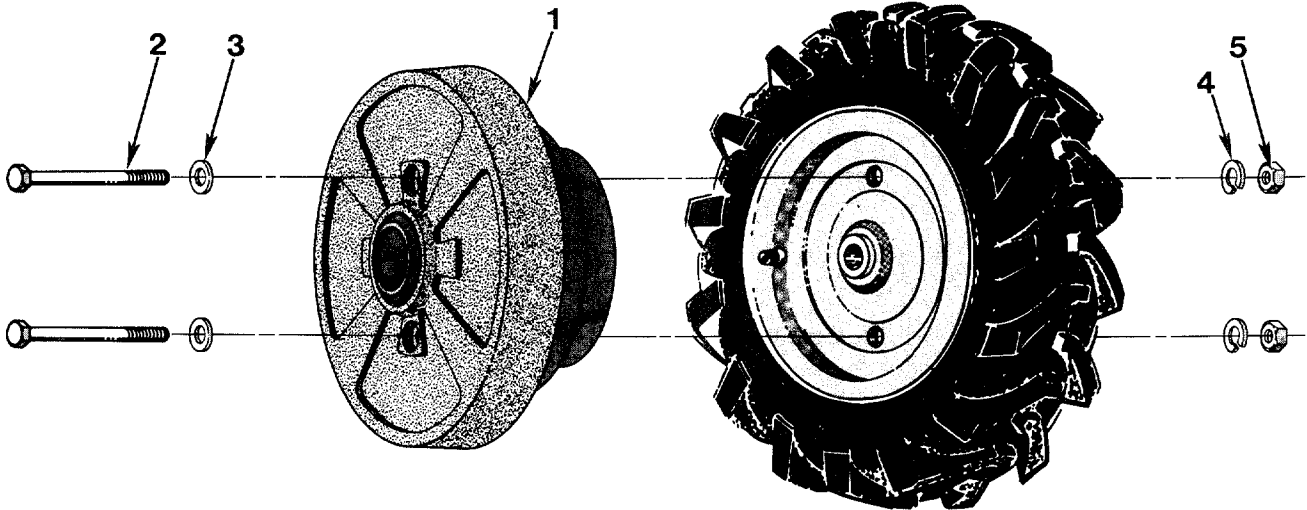

REF. NO.	PART NO.	DESCRIPTION	QTY.	RE-PLACES
1	2382	SHELL — wheel weight	2
2	9661	BOLT — hex hd, 3/8"-16 x 6"	4
3	9904	WASHER — flat, 3/8"	4
4	9913	LOCKWASHER — spring, 3/8"	4
5	9802	NUT — hex, 3/8"-16	4
...	10185	WHEEL WEIGHT KIT — complete. Includes Ref. Nos. 1 through 5, listed above. Instructions included with kit	1

TIRE CHAINS

(Figure 17)

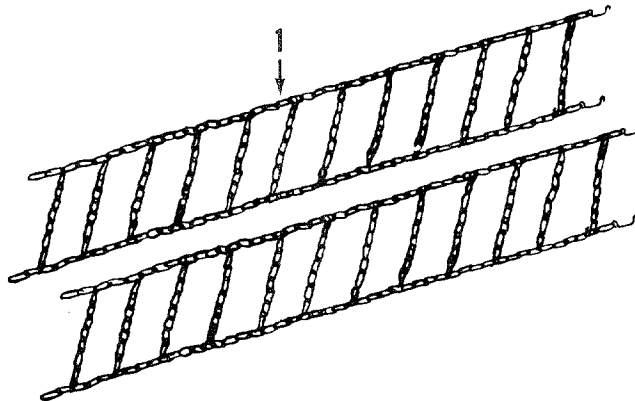

REF. NO.	PART NO.	DESCRIPTION	QTY.	RE-PLACES
1	9146	CHAINS — tire, heavy-duty steel. For standard tread or Bar Tread Tires. Two chains in set	1

ROW MARKER ATTACHMENT

(Figure 18)

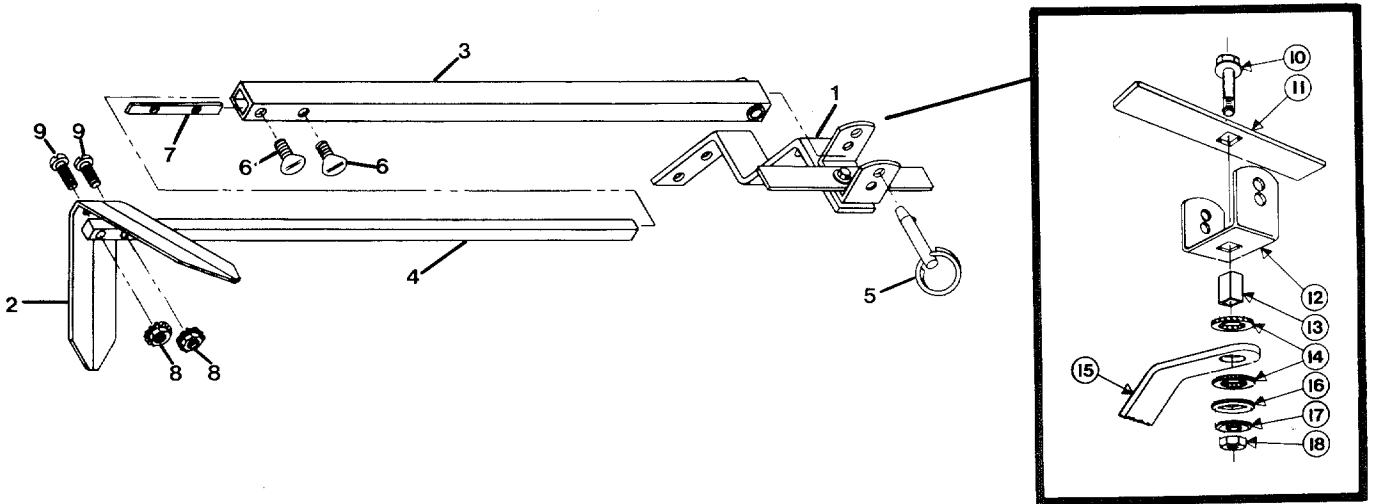

Main Support/Yoke Assembly
Part #1569

REF. NO.	PART NO.	DESCRIPTION	QTY.	RE-PLACES
----------	----------	-------------	------	-----------

ROW MARKER ATTACHMENT — Part #1832 (Complete — Attaches to Part #1317 Furrower Attachment)

1	1569	MAIN SUPPORT & YOKE ASSEMBLY — complete. Includes Ref. No's. 10 through 18 listed below	1
2	1594	MARKER BLADE — blade only	1
3	1597	MARKER ARM — main arm	1
4	1570	MARKER ARM — extension arm with stop pin	1
5	9347	HITCH PIN — included in #1837 Hardware Package	1
6	9786*	THUMBSCREW — 1/4"-20 x 1/2", included in #1837 Hardware Package	2
7	1596	NUT BAR — included in #1837 Hardware Package	1
8	9828*	NUT — hex., 10-24 with attached star washers (see #1837 Hdw. Pkg.)	2
9	9721*	SCREW — round hd., 10-24 x 1", included in Hardware Pkg.	2
...	1837	HARDWARE PKG. — includes: one #9347 Hitch Pin, two #9786 Thumbscrews, one #1596 Nut Bar, two #9828 Hex. Nuts, two #9721 Screws	1
...	1850	ROW MARKER & HILLER/FURROWER ATTACHMENT COMBINATION — complete. Includes: #2638 Hiller/Furrower and #1832 Row Marker	1

ROW MARKER MAIN SUPPORT & YOKE ASSEMBLY — Part #1569

10	9784	BOLT — flanged, self-locking, 3/8"-16 x 1-1/2"	1
11	1593	STOP BAR	1
12	1592	YOKE	1
13	1591	TUBE KEY — square	1
14	1590	WASHER — friction	1
15	1588	MAIN SUPPORT	1
16	1589	WASHER — square hole	1
17	9925	WASHER — disc spring	1
18	9802	NUT — hex., 3/8"-16	1

*Hardware is not available separately. These common hardware items can be easily found at local hardware stores.

NUMERICAL INDEX

HOW TO USE THIS INDEX

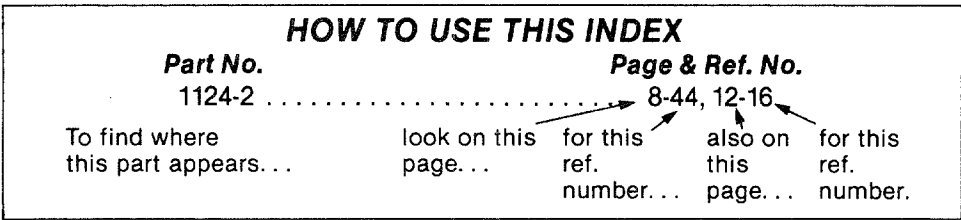

Part No.	Page & Ref. No.	Part No.	Page & Ref. No.	Part No.	Page & Ref. No.
1026	12-4	1881	2-4	2719	6-14
1033	4-9	1919	4-23	2735	23-1
1034	4-30	1920	4-19	2736-01	23-6
1035	8-21	1931	22	2736-02	23-7
1060A	8-51	1932	21	9009	18-24
1086	8-64	2004	24	9092B	18-13
1112	8-70	2006	24-4	9119	2-2, 6-7
1113-1	3-16, 4-17, 6-2	2007	22	9120	2-3, 4-18, 6-6
1117A	6-5	2100	4-20	9122	8-84
1123	8-17	2107	8-38	9125	2-12
1124-2	8-44, 12-16	2120-1	12-10	9145	4-46
1126	8-55	2120-3	8-34	9146	25-1
1129-1, 2	12-3	2123	8-27	9147	4-31
1132-1, 2, 3	8-53	2126	8-82	9199	2-26
1138-1, 2	4-26, 8-32, 12-13, 12-22	2127	12-12	9202	2-18, 16-7, 18-27
1158	20-4	2136	12-24	9205	8-85, 16-6
1160	20-1	2146	3-14, 4-16	9219	2-19
1162	20-9	2163	3-2	9224	18-26
1164	20-10	2195	22-1	9245	4-24
1166-1, 2, 3, 4, 5	8-63	2196	22-2	9250	2-21
1222	8-56	2206	12-23	9265	18-23
1223	8-67	2232	3-7	9266	18-36
1224-1, 2, 3, 4	8-45, 12-17	2260	8-78	9300	8-59
1231	4-8	2263	8-3	9301	8-35, 12-11, 14-5
1232	8-68	2287	24-1	9303	4-27
1233	8-60	2288	24-3	9307	8-71
1237	8-69	2297	22-15	9308	6-16
1269	23-1	2299	22-13	9309	8-50
1270-1A	14-6	2301	22-14	9317	4-7
1270-2A	14-7	2382	25-1	9318	23-12
1299-1	23-6	2447	3-4	9322	4-43
1299-2	23-7	2451	12-2	9336	22-4
1407	20	2461	8-29	9338	4-11
1416	20-7	2475-1	15	9347	26-5
1440	8-77	2475-2	15	9357	8-66
1441	8-76	2522	4-40	9359	8-79
1442	8-74	2527	6-15	9362	4-1, 8-11
1448	21-11	2543	2-23	9363	24-2
1475	18-25	2546	2-25	9384	6-18
1483	4-25	2551	16-8, 2-20	9385	2-22
1492	22-3	2552	16-1	9387	2-28
1554	18-5	2565	4-34	9404	8-54
1561	20-22, 21-4	2566	8-16A	9444	2-16
1569	26-1	2571	18-20	9463	8-2
1570	26-4	2574	3-1	9466	3-3
1588	26-15	2596	4-6	9473	22-7
1589	26-16	2610	6-15	9500	8-33, 12-9
1590	26-14	2616	18-6	9502	8-57
1591	26-13	2628	4-5	9511	8-62
1592	26-12	2629	6-13	9514	2-27
1593	26-11	2636	23-8	9516	8-28
1594	26-2	2638	23	9517	8-49, 12-21
1596	26-7	2654	12-6	9534	6-17
1597	26-3	2656	8-58	9545	8-24
1714	8-46, 12-18	2658	20-19, 21-8	9547	2-14
1832	26	2659	20-17, 21-1	9548	2-1
1837	26	2704	2-11	9552	6-9, 18-3
1850	26	2709-01	5-45	9560	8-80
1873	20	2709-02	5-45A	9566	18-10
1878	8-65	2712	8-75	9567	22-10
		2715	2-13	9572	4-32

Part No.	Page & Ref. No.
9579	8-40
9580	22-17
9604	8-52
9616	12-8
9617	8-48, 12-20
9621	8-61
9622	8-73
9650	2-16A
9655	8-36
9661	25-2
9669	14-2
9672	8-31
9701	8-40, 22-18
9705	20-8
9710	3-11, 20-20, 21-9
9711	14-8
9712	6-1
9715	4-22
9716	20-18, 21-2
9717	20-2
9721	26-9
9725	23-9
9726	8-83
9733	2-24A
9734	6-19
9741	22-5
9743	8-26
9758	21-5
9759	20-11
9765	23-2
9767	20-5
9780	18-4
9782	8-1
9784	26-10
9786	26-6
9800	18-12, 22-12, 22-16
9801	3-6, 4-29, 8-19, 20-15, 21-7, 22-9
9802	3-15, 6-4, 14-10, 23-11, 26-18, 25-5
9803	2-5, 20-13
9804	20-3
9807	15
9808	4-12

Part No.	Page & Ref. No.
9809	18-18
9811	6-20
9824	23-4
9826	18-16
9828	26-8
9831	8-23
9838	4-2, 8-12
9844	2-15, 18-30
9851	16-3
9902	4-10, 8-9, 20-16, 22-6, 23-4
9904	3-13, 4-15, 25-3
9905	20-6
9910	18-11, 22-11, 22-19
9911	8-30
9912	4-32, 18-15, 20-14, 21-6, 22-8
9913	3-12, 4-14, 6-3, 14-9, 20-21, 21-10, 23-10, 25-4
9914	14-3, 20-12, 21-3
9919	3-5, 23-3
9921	18-17
9925	26-17
9928	8-81
9929	6-12
9932	4-4, 8-14
9934	4-3, 8-13
9944	8-37
9952	14-4
9966	4-41
9971	16-2
10185	25
10355	15
10802	15
11522	12-5
11601	8-47
11602	12-19
20421	18-31
20553	4-42
50027	8-39
55053	4-38
85030	8-43
90008	4-28, 8-18

Part No.	Page & Ref. No.
90038	7-21
90039	2-24
90044	7-10, 9-7
90046	3-18, 4-13
90047	9-5, 19-21
94017	12-8A
96510	19-19
96514	18-14
96515	19-1
96520	18-9
97020	19-2
97067	12-7
1900758	8-4
1900759	8-86
1900763	2-17
1900766	4-21
1900767	4-39
1900944	19-7
1901084	5-35
1901085	5-35
1901086	5-37
1901087	5-37
1901118	15
1901439	8-20
1901440	8-22
1908112	18-8
1908117	18-29
1908118	18-28
1908211	12-1
1908212	12-14
1900468010	3-8
1900469010	3-9
1900854010	2-6
1900855010	2-9
1900856010	2-7
1900857010	2-8
1900858010	2-10
1900860010	3-10
1900867010	6-8
1900869010	8-16
1900870010	8-10
1900871010	14-1
1900878010	8-25
1900879010	8-42
1900880010	8-72
1900881010	12-15

NOTES



TROY-BILT MANUFACTURING CO., 102nd Street & 9th Avenue, Troy, New York 12180
For Technical Service, call Toll-Free: 1-800-833-6990 — For Parts, call Toll-Free: 1-800-648-6776
GARDEN WAY BRANCH CANADA, 1515 Matheson Blvd. E., Unit B11, Mississauga, Ontario L4W 2P5
Call Toll-Free: 1-800-225-3585