



## MODELS

---

42020 – Recoil Start  
42021 – Electric Start

© 1997 GARDEN WAY INCORPORATED

# Owner's Manual

---

## 17", 3 H.P. Single Stage Snowthrower

- Safety
- Operation
- Maintenance

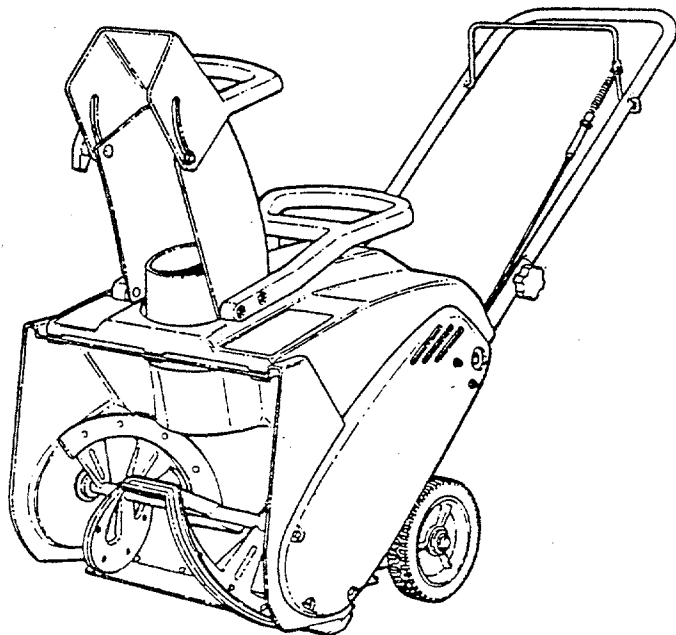

INSTRUCTION No. 1904698 (I.R. 6/97)

Ref. No. 4-8281

# IMPORTANT SAFETY INSTRUCTIONS

**WARNING:** This powerful machine is capable of amputating hands and feet and can throw objects that can cause injury and damage! Failure to comply with the following instructions may result in serious injury to the operator or other persons. The owner of the snow thrower must understand these instructions and, furthermore, must allow only persons who understand these instructions to operate snow thrower. Each person operating the snow thrower must be of sound mind and body and must not be under the influence of any substance which might impair vision, dexterity, or judgment. If you have any questions pertaining to your snow thrower which your dealer cannot answer to your satisfaction, call or write the Technical Service Department at Garden Way Incorporated, 1 Garden Way, Troy New York, 12179. Phone: (800) 520-5520.

## PROTECTION FOR CHILDREN

1. DO NOT allow children in the area when snow thrower is being operated.
2. DO NOT allow pre-teenage children to operate snow thrower.
3. DO NOT allow irresponsible teenagers to operate the machine - allow teenagers only if exhibiting mature judgment and then only after being thoroughly instructed and under the close supervision of an experienced operator.
4. Keep the area clear of all persons, particularly small children and pets
5. Know how to STOP the snow thrower and disengage the controls quickly.

## PREPARATION

1. Read this manual, get to know where all controls are located and practice how to use them before starting for the first time, and at the beginning of each season. Pay attention to Warning and Instructional Decals on engine and snow thrower.
2. Wear adequate winter clothing including boots which will give you maximum footing on slippery surfaces. Exercise CAUTION to avoid slipping or falling.
3. Before the first snow fall, check the area to be cleared and remove all objects such as doormats, sticks, toys, wires, rocks, etc., which could be hurled or jam the snow thrower.
4. Survey the area to be cleared beforehand and plan where snow is to be blown. Be prepared to release auger/impeller clutch or to change discharge chute direction quickly to discharge away from windows, cars, buildings and doorways to avoid property damage or personal injury from hurled objects.
5. Handle fuel with care. Store only in an approved fuel container. Move the machine outdoors where fumes can be safely dissipated before filling fuel tank. Never add fuel to a running engine or hot engine. Replace fuel cap securely and wipe up spilled fuel.

## OPERATIONAL PRECAUTIONS

1. Before starting, make visual check to make sure auger/impeller housing is clear and all guards and shields are in place and tight.
2. Warn everyone in advance to stay clear of area but keep especially watchful for children and pets darting into area while operating.

## OPERATIONAL PRECAUTIONS

3. Start engine only where exhaust fumes will be safely dissipated, allow a brief warm-up period, practice operation of controls outside before putting the machine to work.
4. Should the auger/impeller become clogged, release the auger/impeller clutch control and, as an additional precaution, STOP the engine before attempting to unclog the auger/impeller or discharge chute.
5. After striking a foreign object, STOP the engine (motor), remove the wire from spark plug, thoroughly inspect the snow thrower for any damage, and repair the damage before restarting and operating the snow thrower.
6. STOP the engine if the machine starts to vibrate excessively as this normally indicates mechanical problems. Disconnect the spark plug wire to prevent unintentional starting before servicing or repairing the machine.
7. DO NOT clear snow across the face of slopes. Exercise extreme CAUTION when changing direction on slopes. DO NOT attempt to clear steep slopes.
8. STOP the engine and remove the key whenever you leave the unit unattended to eliminate the possibility of children or untrained adults from attempting to operate the machine.
9. Release clutch control and make sure auger/impeller has STOPPED before rotating discharge chute, adjusting deflector, or placing hands near auger/impeller.
10. DO NOT use snow thrower on surfaces above ground level, such as, a roof of a building.
11. Exercise extreme CAUTION when operating on or crossing gravel drives, walks, or roads. Stay alert for hidden hazards or traffic.
12. DO NOT overload the machine capacity by attempting to clear snow at too fast a rate.
13. Never operate the machine at high transport speeds on slippery surfaces. Look behind and use care when backing.
14. Disengage power to the auger/impeller when snow thrower is transported or not in use.
15. Use only attachments and accessories approved by the manufacturer of the snow thrower (such as wheels weights, counterweights, cabs and the like).
16. Never operate the snow thrower without good visibility or light. Always be sure of your footing, and keep a firm hold on the handles. Walk; never run.

# TABLE OF CONTENTS

SECTION 1 - IMPORTANT SAFETY INSTRUCTIONS .....	2
TABLE OF CONTENTS.....	3
SECTION 2 - OPERATING INSTRUCTIONS .....	4-8
Pre-start Checklist .....	4-5
Starting & Stopping Engine (Recoil Start Models).....	6-7
Starting & Stopping Engine (Electric Start Models) .....	7-8
Starting & Stopping Auger .....	7-8
SECTION 3 - MAINTENANCE INSTRUCTIONS .....	9
Changing Engine Oil .....	9
Checking Auger Drive Belt .....	9
Checking Auger Flite Shoes.....	9
Checking Clutch Control Cable.....	9
SECTION 4 - ADJUSTMENTS AND REPAIR.....	10-12
Auger Drive Belt Adjustment.....	10-11
Auger Drive Belt Replacement .....	11-12
Auger Flite Shoe Replacement.....	12
TROUBLESHOOTING .....	13
SERVICE SCHEDULE .....	13
Maintenance/Replacement Parts.....	13
WARRANTY.....	14

# Section 2 - OPERATING INSTRUCTIONS

## 2.1 PRE-START CHECK LIST

Make the following checks and perform the service required before each start-up.

2.1.1. Check guards, chutes, deflectors and covers to make sure all are in place and securely tightened.

2.1.2. Check auger control to insure it works freely. See Figure 2.1.

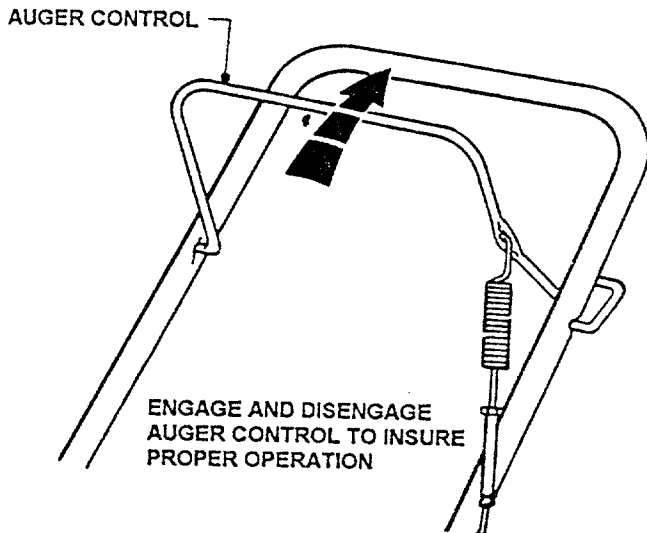

FIGURE 2.1

2.1.3. Check chute operation. Rotate chute to insure smooth rotation throughout its range.

⚠

### CAUTION

⚠

Use approved fuel container. **DO NOT** smoke near open fuel container. **DO NOT** fill fuel tank indoors or when engine is running. Allow engine to cool for at least ten minutes before refilling. Wipe off any spilled fuel before starting engine. **DO NOT** run engine indoors.

2.1.4. Mix fresh, good quality unleaded gasoline and 2-cycle engine oil or equivalent. Mix fuel and oil to a 32:1 ratio. See Figure 2.2.

2.1.5. Add premix fuel to tank after pushing the machine outside where fumes can safely dissipate. Make sure cap is tightened after refueling. Refer to Engine Owners Manual for specifications.

2.1.6. Check auger housing, must be free of all obstructions. Clean engine of any accumulation of spilled fuel, dirt, etc.

## STANDARD FLUID MEASUREMENT (32:1 Ratio)

GASOLINE (Gallons)	2 CYCLE OIL (Ounces)
0.25	1.00
0.50	2.00
0.75	3.00
1.00	4.00
1.25	5.00
1.50	6.00
2.00	8.00

## METRIC FLUID MEASUREMENT (32:1 Ratio)

GASOLINE (Liters)	2 CYCLE OIL (Cubic Centimeters)
0.50	15.63
1.00	31.26
1.50	46.88
2.00	62.50
2.50	78.15
3.00	93.75
4.00	125.00

FIGURE 2.2



(Continued on Next Page)

# Section 2 - OPERATING INSTRUCTIONS

## 2.1 PRE-START CHECK LIST

(Continued from Previous Page)

Make the following checks and perform the service required before each start-up.

	CAUTION	
<p>Never use an electrical extension cord that is damaged. A damaged electrical extension cord could cause a shock or fire. Thoroughly inspect electrical extension cord before using machine. If cord is damaged, do not use and do not operate machine. Replace damaged cord immediately. Contact your TROY BILT service dealer for assistance. To reduce the risk of electric shock, use only with an extension cord intended for outdoor use having a cord type: SW-A, SOW-A, STW-A, STOW-A, SJW-A, SJTW-A or SJTOW-A.</p>		

2.1.7. Check and make sure extension cord is in good condition. Extension cord should not have any broken insulation or exposed wires. Use an extension cord that is heavy enough to carry the correct amount of current to the machine. See Figure 2.3 for correct size to use depending on cord length and nameplate ampere rating. If in doubt, use the next heavier gauge cord.

MINIMUM GAUGE FOR CORD SETS					
120 Volt		Total Length of Cord in Feet			
Rating - Amps		25 ft.	50 ft.	100 ft.	150 ft.
More Than	Not More Than	A.W.G.			
0	6	18	16	16	14
6	10	18	16	14	12
10	12	16	16	14	12
12	16	14	12	Not Recommended	

FIGURE 2.3

2.1.8. Check the AC electrical outlet that will be used and make sure it is a polarized outlet. The machine has a polarized plug (one blade of plug is wider than the other) that will accept a polarized extension cord. The extension cord will fit into a polarized outlet (receptacle) only one way. If plug does not fit fully into your outlet, reverse the plug. If it still does not fit, contact a qualified electrician to install a proper polarized outlet. DO NOT modify or change this polarized plug in any way.

# Section 2 - OPERATING INSTRUCTIONS

## 2.2 STARTING, STOPPING & OPERATION (RECOIL START MODELS)

(Go to Page 7 for Electric Start Models)

### 2.2.1. ENGINE & AUGER

1. Move choke control to the choke "ON" position. See Figure 2.4.

**NOTE:** Stop the auger by releasing the auger control. Stop the engine by turning the key switch to the "OFF" position.

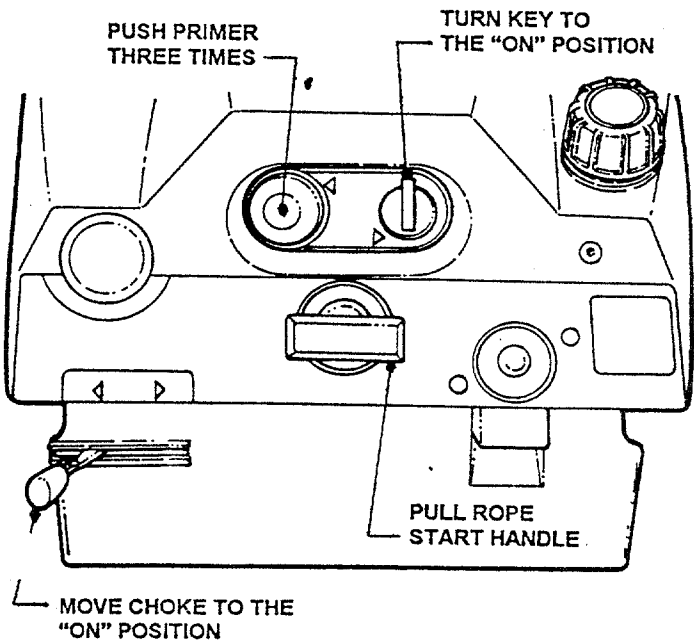

FIGURE 2.4

2. Turn ignition key to the "ON" position.
3. Push primer button three times to start a cold engine. **NOTE:** Do not use primer button to start warm engine.
4. Pull rope start handle to crank engine.
5. After engine starts, move the choke control to the no choke "OFF" position. Allow a brief warm-up until engine runs smooth.

**CAUTION**

Objects can be thrown by the snow thrower while it is in operation. Thrown objects could cause serious injury to the operator or bystanders. Always wear safety goggles or other suitable eye protection. Keep people and pets away from area.

### 2.2.2. ENGAGING AUGER

1. Pull auger control against handle to engage auger. See Figure 2.5.

**CAUTION**

Release auger clutch control and make sure auger/impeller has STOPPED before rotating discharge chute, adjusting deflector, or placing hands near auger/impeller.

### 2.2.3. DISCHARGE CHUTE and DEFLECTOR ADJUSTMENT

1. Release auger control and allow auger to come to a complete stop before performing any adjustments.
2. Loosen deflector knob and position deflector to desired angle. Retighten knob.
3. Rotate discharge chute in desired direction. See Figure 2.6.

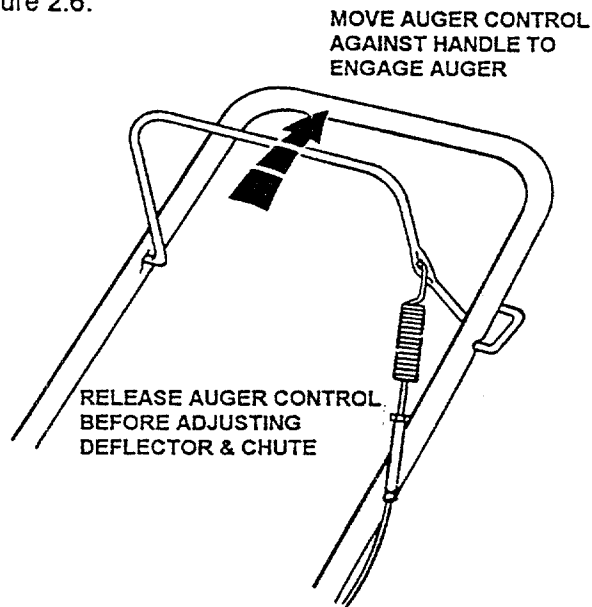

FIGURE 2.5

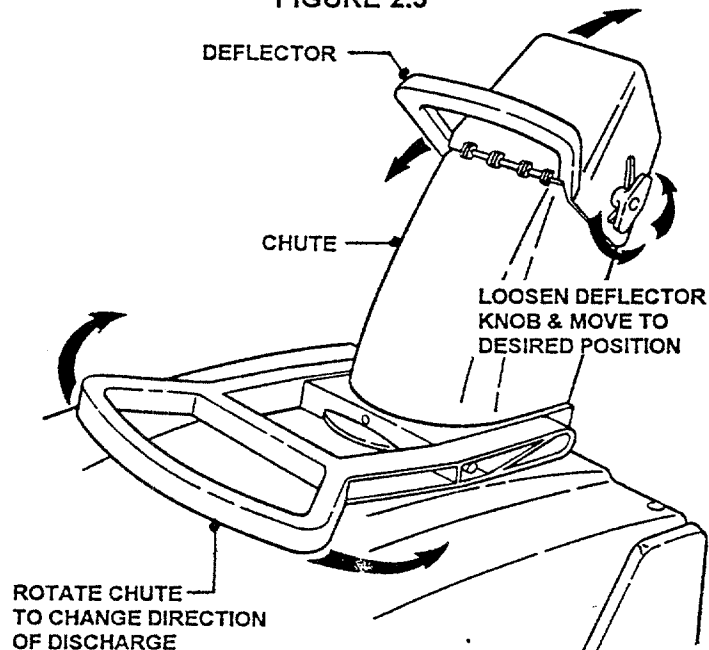

FIGURE 2.6

## Section 2 - OPERATING INSTRUCTIONS

### 2.2.4. STOPPING

Stop the auger by releasing the auger control. Stop the engine by turning the key switch to the "OFF" position. Always remove key from key switch before leaving machine unattended. See Figure 2.7.

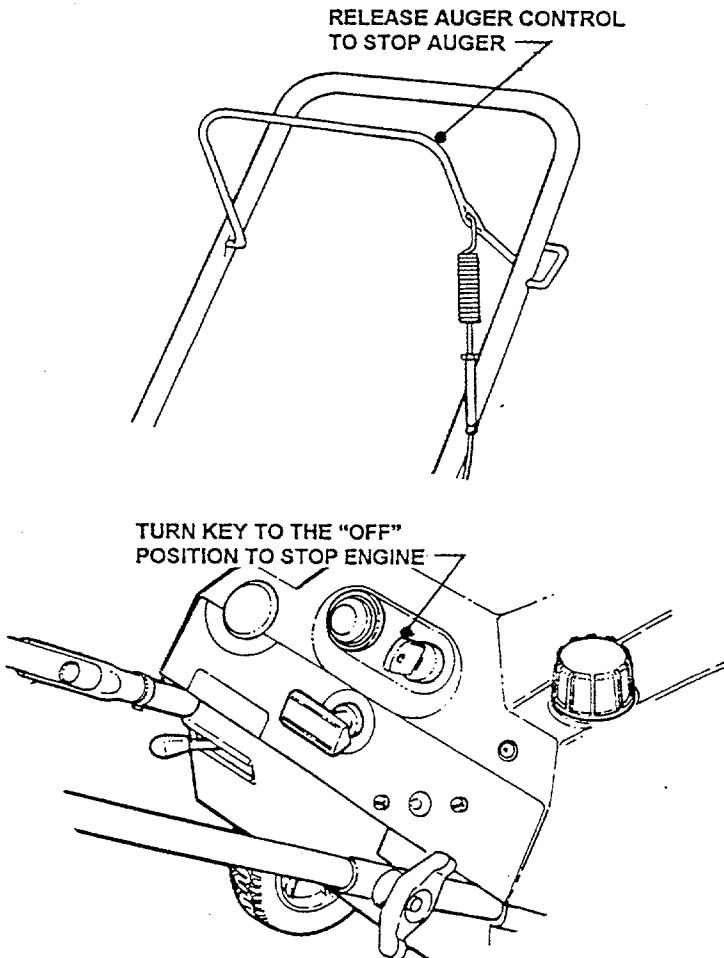

FIGURE 2.7

### 2.2 STARTING, STOPPING & OPERATION (ELECTRIC START MODELS)

(Go to Page 6 for Recoil Start Models)

#### 2.2.5. ENGINE & AUGER

**CAUTION**

Never use an electrical extension cord that is damaged. A damaged electrical extension cord could cause a shock or fire. Thoroughly inspect electrical extension cord before using machine. If cord is damaged, do not use and do not operate machine. Replace damaged cord immediately. Contact your TROY BILT service dealer for assistance. To reduce the risk of electric shock, use only with an extension cord intended for outdoor use having a cord type: SW-A, SOW-A, STW-A, STOW-A, SJW-A, SJTW-A or SJTOW-A.

1. Connect the power cord to the starter switch box on machine's control panel then plug the other end into 120 volt AC receptacle.
2. Turn ignition key to the "ON" position.
3. Move choke control to the choke "ON" position. See Figure 2.8.
4. Push primer button three times to start a cold engine. **NOTE:** Do not use primer button to start warm engine.
5. Push the electric starter button. **DO NOT** hold button for more than 20 seconds to avoid damaging the starting motor. See Figure 2.8.
6. After engine starts, move the choke control to the no choke "OFF" position. Allow a brief warm-up until engine runs smooth.
7. Disconnect power cord from machine. Disconnect power cord from AC receptacle and remove cord from area where machine will be in operation.

**NOTE:** Stop the auger by releasing the auger control. Stop the engine by turning the key switch to the "OFF" position.

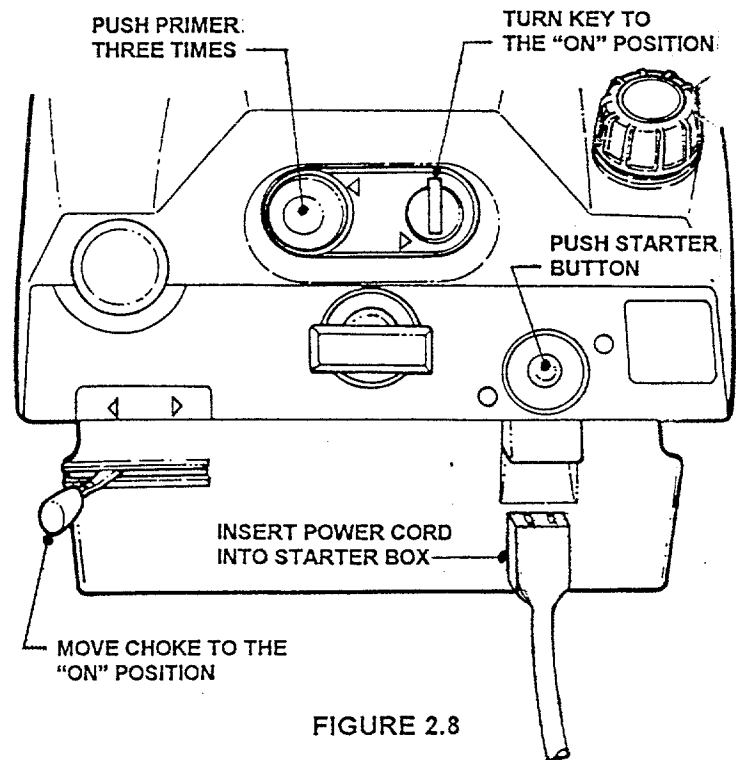





FIGURE 2.8

## Section 2 - OPERATING INSTRUCTIONS

	<b>CAUTION</b>	
<p>Objects can be thrown by the snow thrower while it is in operation. Thrown objects could cause serious injury to the operator or bystanders. Always wear safety goggles or other suitable eye protection. Keep people and pets away from area.</p>		

### 2.2.6. ENGAGING AUGER

1. Pull auger control against handle to engage auger. Refer to Figure 2.5.

	<b>CAUTION</b>	
<p>Release auger clutch control and make sure auger/impeller has STOPPED before rotating discharge chute, adjusting deflector, or placing hands near auger/impeller.</p>		

### 2.2.7. DISCHARGE CHUTE and DEFLECTOR ADJUSTMENT

1. Release auger control and allow auger to come to a complete stop before performing any adjustments.
2. Loosen deflector knob and position deflector to desired angle. Retighten knob.
3. Rotate discharge chute in desired direction. Refer to Figure 2.6.

### 2.2.8. STOPPING

Stop the auger by releasing the auger control. Stop the engine by turning the key switch to the "OFF" position. Always remove key from key switch before leaving machine unattended. Refer to Figure 2.7.



## Section 3 - MAINTENANCE

### 3.1 INTRODUCTION

To retain the quality of the snow thrower, use genuine TROY BILT replacement parts only. Contact a local TROY BILT dealer for parts and service assistance. For the correct part or information for a particular snow thrower, always mention model and serial number.

### 3.2 SERVICE - AFTER FIRST 5 HOURS

#### 3.2.1 CHECK AUGER DRIVE BELT

1. Visually check engine drive belt for cracking, fraying, severed or belt strands exposed. Replace belt before operating snow thrower. See Figure 3.1

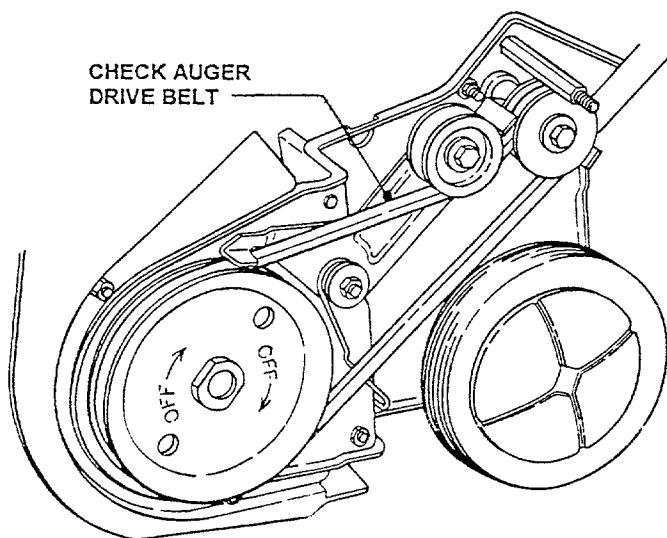

FIGURE 3.1

#### 3.2.2 CHECK AUGER FLITE SHOE

1. Visually check flite shoes for cracking, fraying, severed or belt strands exposed. Replace flite shoes before operating snow thrower. See Figure 3.2.

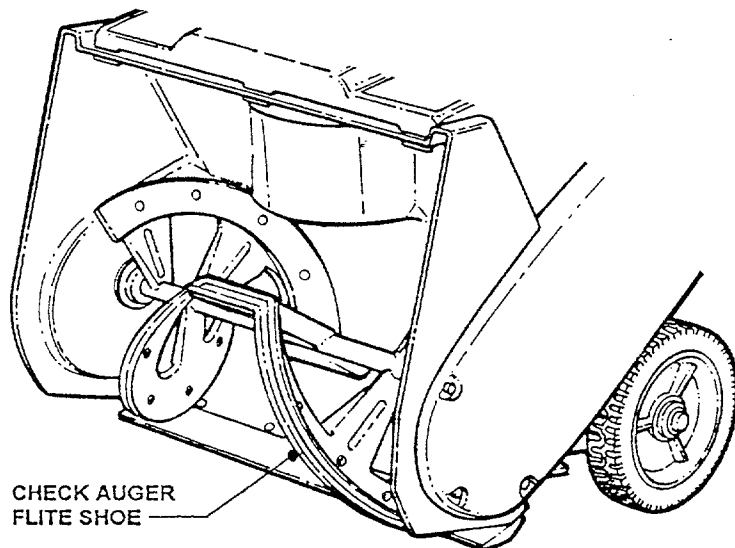

FIGURE 3.2

#### 3.2.2 CHECK AUGER CLUTCH CONTROL CABLE

1. Visually check cable for fraying, kinking or severed cable strands. Replace cable and adjust tension before operating snow thrower. See Figure 3.3.

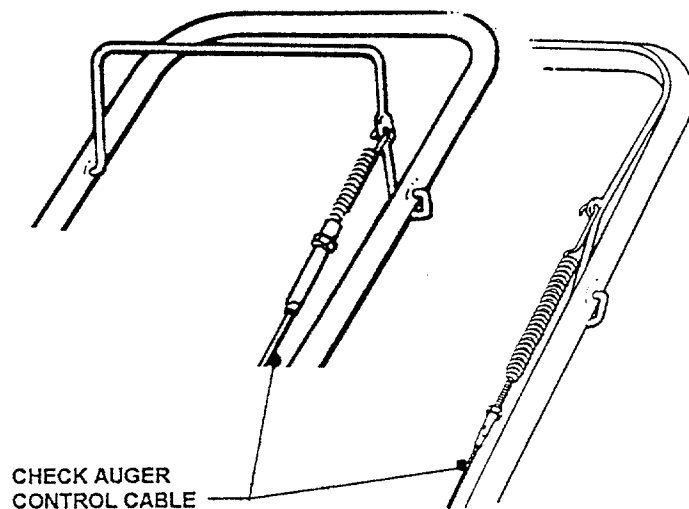

FIGURE 3.3

### 3.3 ANNUALLY (END OF EACH SEASON)

Perform all maintenance as described in the maintenance schedule.

#### 3.3.1. Engine

Refer to engine owner's manual for service instructions.

#### 3.3.2. Spark Plug

Refer to engine owner's manual for service instructions.

### 3.4 STORAGE PROCEDURE

Refer to the Engine Owner's Manual for directions regarding engine storage preparations. Prepare the snow thrower for "end of season" storage as follows:

1. Drain fuel from fuel tank and let engine run until all fuel is out of the carburetor.
2. Disconnect and remove the spark plug wire away from spark plug before any other preparations are made!
3. Tape all openings closed to prevent spraying water into exhaust or air intakes during washing.
4. Tilt snow thrower up on its wheels and thoroughly clean the underside of the auger.
5. Lubricate all exposed metal with a light coating of oil to prevent corrosion.
6. Store the machine in a shed or other dry area protected from weather.

# Section 4 - REPAIR & ADJUSTMENTS

**CAUTION**

Before attempting any adjustments, maintenance, service, or repairs, stop engine and auger, always remove key from ignition switch, remove spark plug wire and secure wire away from spark plug.

**IMPORTANT:** DO NOT rotate cable beyond the point to where all of slack out of cable. Cable has to have a certain amount of slack for the auger brake to stop auger when auger clutch control is released. If all of the adjustment is utilized at the upper handle go to Section 4.1.2. for alternate adjustment.

## 4.1 AUGER BELT ADJUSTMENT/REPLACEMENT

When operating machine release the auger clutch control, auger should come to a complete stop in 5 seconds. If auger does not come to a complete stop in the required time, check and adjust belt tension. Inspect belt frequently for signs of excessive wear. Observe drive belt for slippage due to wear when operating machine.

### 4.1.1. AUGER BELT ADJUSTMENT (UPPER CABLE ADJUSTMENT)

If slippage does occur adjust as follows.

1. Measure auger clutch control cable extension from a relaxed position to full extended position. See Figure 4.1.
2. Proper extension should be between 1/2" minimum to 3/4" maximum extension. NOTE: Measure from the top of spring (The top is in relation to where spring hooks into auger clutch control).

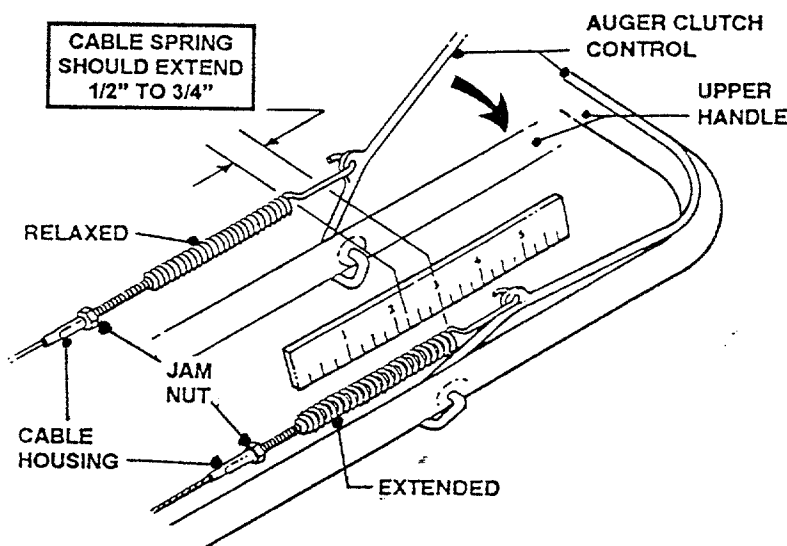

FIGURE 4.1

### 4.1.2. AUGER BELT ADJUSTMENT (IDLER PULLEY ADJUSTMENT)

If upper cable adjustment performed in Section 4.1.1. and correct cable extension can not be accomplished, adjustment can be made at the idler pulley. All adjustment made in Section 4.1.1. will have to be reversed from the upper end of cable.

1. Loosen jam nut at the upper end of cable. Hold threaded end of cable and then turn metal housing of cable counter clockwise until threaded portion of cable is extracted from metal housing. Reinstall 1/2" of the threaded portion of cable back into metal housing. Retighten jam nut.
2. Remove belt cover. See Figure 4.2

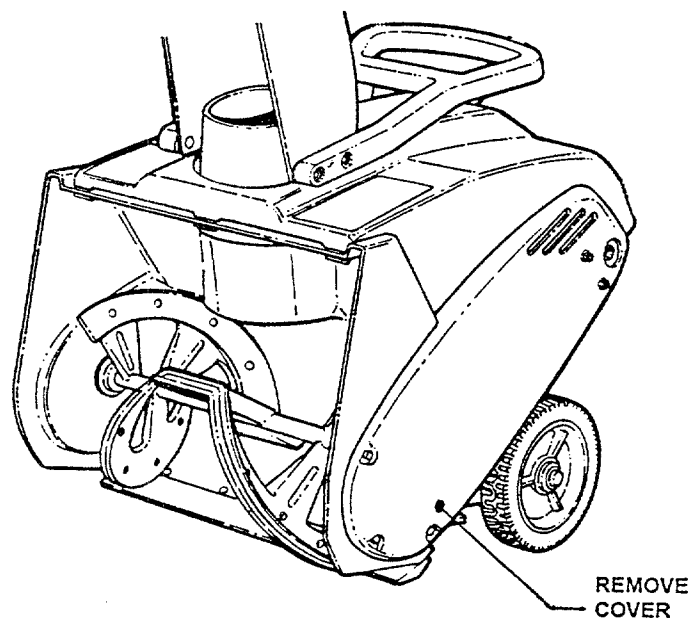

FIGURE 4.2

(Continued on the Next Page)

3. Loosen jam nut at the upper end of cable. Hold threaded end of cable and then turn cable clockwise until correct extension is achieved. Retighten jam nut.

## Section 4 - REPAIR & ADJUSTMENTS



### CAUTION



Before attempting any adjustments, maintenance, service, or repairs, stop engine and auger, always remove key from ignition switch, remove spark plug wire and secure wire away from spark plug.

#### 4.1.2. AUGER BELT ADJUSTMENT (IDLER PULLEY ADJUSTMENT) (Continued From Previous Page)

3. Loosen nut and bolt that secures the idler pulley to idler arm. Move idler pulley down for more tension or up for less tension on belt. See Figure 4.3. Retighten bolt and nut securely.
4. Recheck cable for proper extension.
5. Reinstall belt cover.

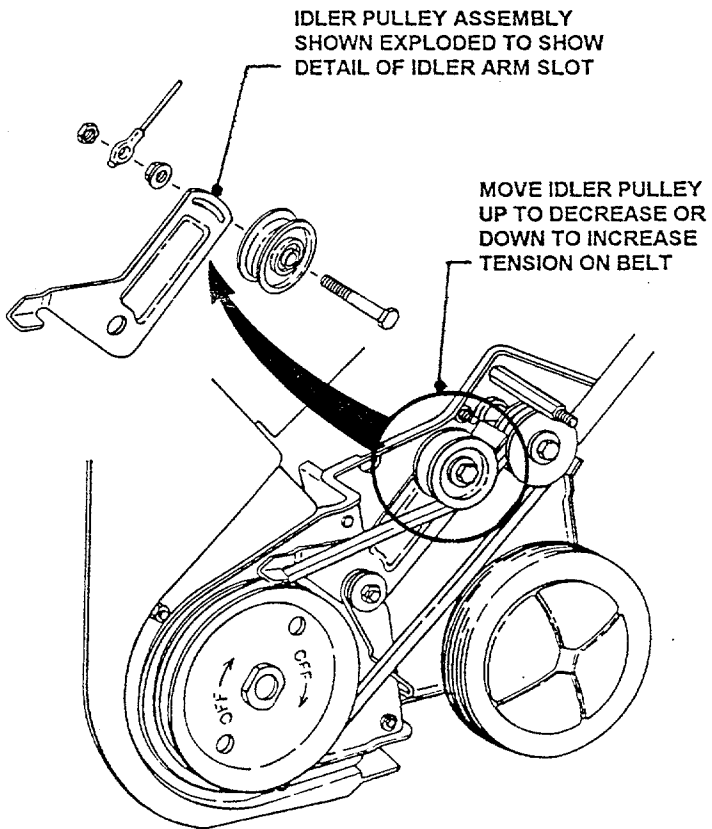

FIGURE 4.3

#### 4.1.3. AUGER BELT REPLACEMENT

Inspect belt frequently for signs of excessive wear. Visually check engine drive belt for cracking, fraying, severed or belt strands exposed.

1. Remove belt cover. Refer to Figure 4.2.
2. Remove belt guide. See Figure 4.4.
3. Push the spring tensioned idler pulley down and remove belt.
4. Push the spring tensioned idler pulley down and install new belt. See Figure 4.5.

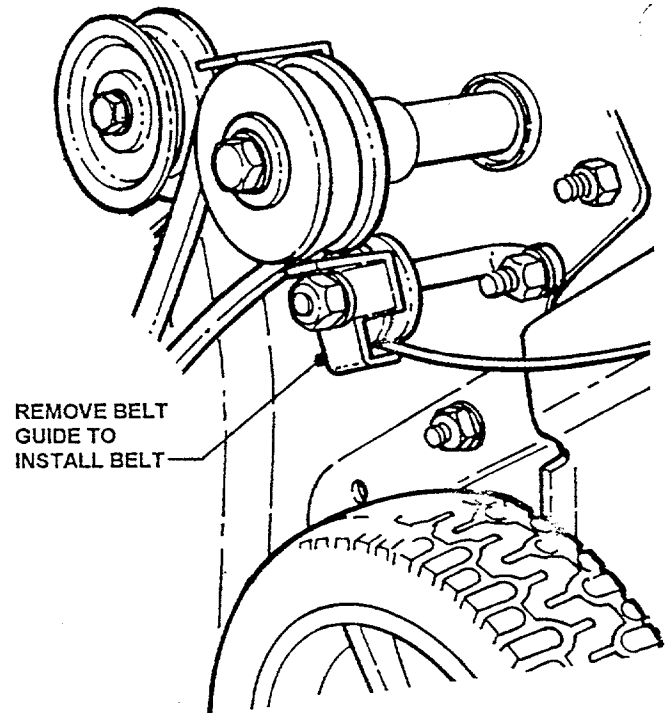

FIGURE 4.4

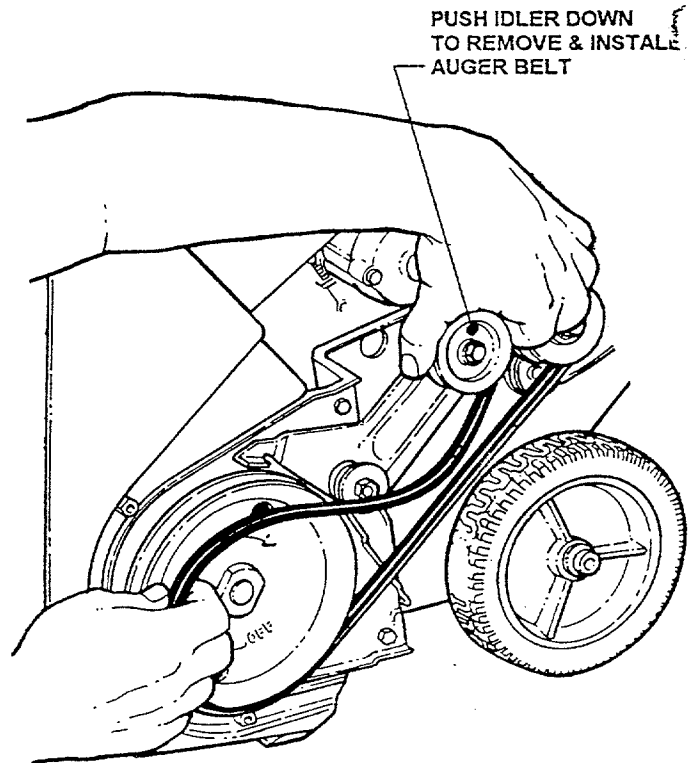

FIGURE 4.5

# Section 4 - REPAIR & ADJUSTMENTS

**CAUTION**

Before attempting any adjustments, maintenance, service, or repairs, stop engine and auger, always remove key from ignition switch, remove spark plug wire and secure wire away from spark plug.

### 4.1.3. AUGER BELT REPLACEMENT (Continued From Previous Page)

5. Reinstall belt guide. **IMPORTANT:** Make sure when reinstalling belt guide that it does not touch drive pulley. Belt guide should have an equal amount of clearance on both belt guide fingers. See Figure 4.6.
6. See Sections 4.1.1. & 4.1.2. Auger Belt Adjustment for new belt adjustment. Adjust belt as described in these sections.
7. Reinstall belt cover and tighten screws securely. **DO NOT** overtighten.

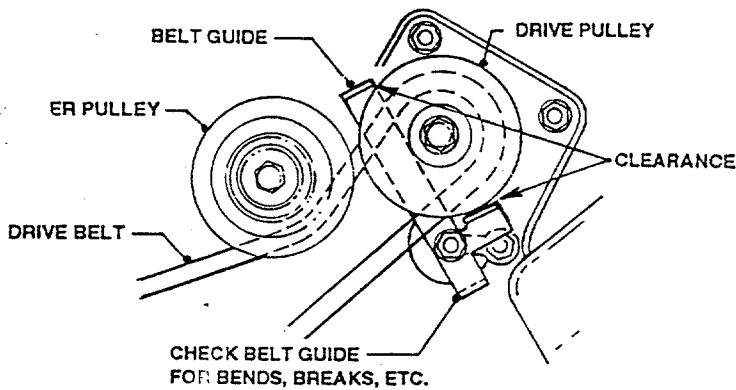

FIGURE 4.6

### 4.1.4. AUGER FLITE SHOE REPLACEMENT

Inspect flite shoes frequently for signs of excessive wear. Visually check flite shoes for cracking, fraying, severed or belt strands exposed. #1904695 Flite Shoe Kit will be required to replace existing flite shoes.

1. Tilt machine backward to gain access to auger. Secure machine in the tilted position to prevent tipping over.
2. Remove all self-tapping screws that secure the flite shoes to auger. Save screws for future use.
3. Install new flite shoes to auger using self-tapping screws removed previously. Tighten screws securely. **DO NOT** overtighten. See Figure 4.7.

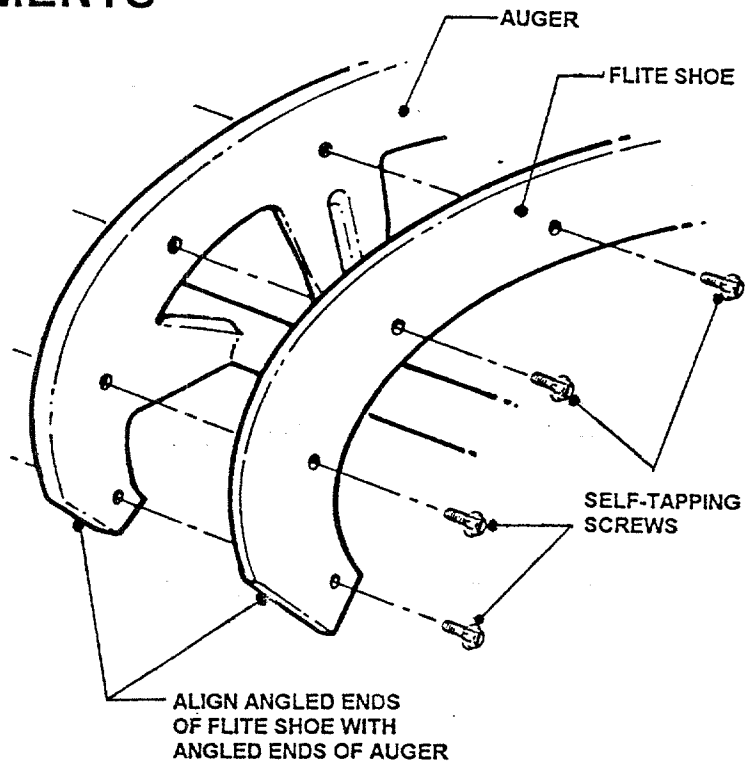

FIGURE 4.7

# TROUBLESHOOTING

PROBLEM	PROBABLE CAUSE	CORRECTIVE ACTION
Engine Will Not Start Using Recoil Starter	1. Fuel tank empty.	1. Fill fuel tank with fresh fuel/oil mix.
	2. Engine needs choking & priming.	2. Move choke control to "CHOKE" position. Push primer bulb three times.
	3. Spark plug wire disconnected.	3. Place spark plug wire onto spark plug.
Engine Will Not Start Using Electric Starter	1. Power extension cord not plugged into machine or 110 Volt outlet.	1. Plug power extension cord into machine & into 110 Volt outlet.
	2. Power extension cord damaged.	2. Discard damaged power extension cord
	3. Starter switch damaged or faulty.	3. Replace starter switch.
Engine Stalls or Stops After Running	1. Fuel and 2-Cycle oil mixture ratio incorrect.	1. Mix fuel and 2-Cycle oil to 32:1 ratio.
	2. Choke control in the "CHOKE" position.	2. Move choke control to "OFF" position.
	3. Fuel tank empty.	3. Fill with fuel to proper level.
	4. Air intake clogged with snow or debris.	4. Unclog air intake.
	5. Spark plug defective or gap set improperly.	5. Service spark plug.
	6. Water, debris or stale fuel in fuel system.	6. Drain and clean fuel system.
Engine Loses Power	1. Fuel and 2-Cycle oil mixture ratio incorrect.	1. Mix fuel and 2-Cycle oil to 32:1 ratio.
	2. Spark plug faulty.	2. Service spark plug.
	3. Water, debris or stale fuel in fuel system.	3. Drain and clean fuel system.
Excessive Vibration	1. Damaged, out of balance or bent auger.	1. Service auger.
	2. Loose engine or auger components.	2. Service and tighten loose components.
	3. Loose or missing flightings.	3. Replace flightings.
	4. Cracked, severed or frayed belt	4. Replace belt.
	5. Bent or loose idler pulley	5. Tighten or replace pulley.
Poor Snow Discharging	1. Clogged discharge chute.	1. Stop engine and unclog discharge chute.
	2. Damaged or bent auger or components.	2. Service auger or components.
	3. Cracked, severed or frayed belt.	3. Replace belt.
	4. Belt tension out of adjustment.	4. Adjust belt tension.
	5. Auger flightings damaged or missing.	5. Replace flightings.

## SERVICE SCHEDULE

ITEM	SERVICE PERFORMED	REF.	EACH USE	5 HRS	25 HRS	50 HRS	100 HRS	EACH SEASON
Spark Plug	Replace	Engine Manual.					X	
Engine Cooling System	Clean Shroud & Fins	Engine Manual					X	
Drive Belts	Check For Wear And Tension	Page 9-12			X	X		X
Auger & Flight Shoe	Check For Wear, Damage & Replacement	Page 9-12	X					

### 4.2. MAINTENANCE/REPLACEMENT PARTS

MAINTENANCE PARTS	
Auger Drive Belt	1904625
Auger Clutch Control Cable	1904575
Auger Flite Shoe Kit for 17" Auger Models	1904695
Parts Manual for 17" 3 H.P. Snow Thrower	1904697



## 2 YEAR LIMITED WARRANTY

For two (2) years from purchase date for the original purchaser's residential, non-commercial use, TROY BILT, through any TROY BILT dealer will replace, free of charge (except for taxes where applicable), any part or parts found upon examination by the factory at Troy, New York, to be defective in material or workmanship or both.

For ninety (90) days from purchase date for the original purchaser's commercial, rental, or other non-residential use, TROY BILT, through any TROY BILT dealer will replace, free of charge, any part or parts found upon examination by the factory at Troy, New York, to be defective in material or workmanship or both.

All transportation costs incurred by the purchaser in submitting material to a TROY BILT dealer for replacement under this warranty must be paid by the purchaser.

This warranty does not apply to engines and their components, hydro transmissions, gear drive transmissions and batteries, as these items are warranted separately. This warranty does not apply to parts that have been damaged by accident, alteration, abuse, improper lubrication, normal wear, or other cause beyond our control.

There is no other express warranty.

### DISCLAIMER OF WARRANTY

Implied warranties, including those of merchantability and fitness for a particular purpose, are limited to two (2) years from purchase date for the original purchaser's residential or other non-commercial use, and ninety (90) days from purchase for the original purchaser's commercial, rental or other non-residential use, and to the extent permitted by law, any and all implied warranties are excluded. This is the exclusive remedy. Remedies for consequential damages, under any and all warranties are excluded.

Some states do not allow limitations on how long an implied warranty lasts, or do not allow the exclusion or limitation of incidental or consequential damages, so the above limitation or exclusion may not apply to you.

This warranty gives you specific legal rights, and you may also have other rights which vary from state to state.

**WARNING: THE USE OF REPLACEMENT PARTS OTHER THAN GENUINE TROY BILT PARTS MAY IMPAIR THE SAFETY OF TROY BILT PRODUCTS AND WILL VOID ANY LIABILITY AND WARRANTY BY TROY BILT ASSOCIATED WITH THE USE OF SUCH PARTS.**

**IMPORTANT:** Please fill out the attached TROY BILT Product Registration Card immediately and mail to:  
TROY BILT, 1 Garden Way, Troy, New York 12179.

Owner's Manual for



---

# SINGLE STAGE SNOW THROWER

## MODELS

42020 - Recoil Start

42021 - Electric Start

 **WARNING:** The engine exhaust from this product contains chemicals known to the State of California to cause cancer, birth defects or other reproductive harm.