



Owner/Operator Manual

Snowthrower

- Safety
- Assembly
- Controls
- Operation
- Maintenance

Models

- 42010 - 8 HP, 24" Auger
- 42030 - 8 HP, 24" Auger
- 42012 - 10 HP, 26" Auger
- 42031 - 10 HP, 26" Auger

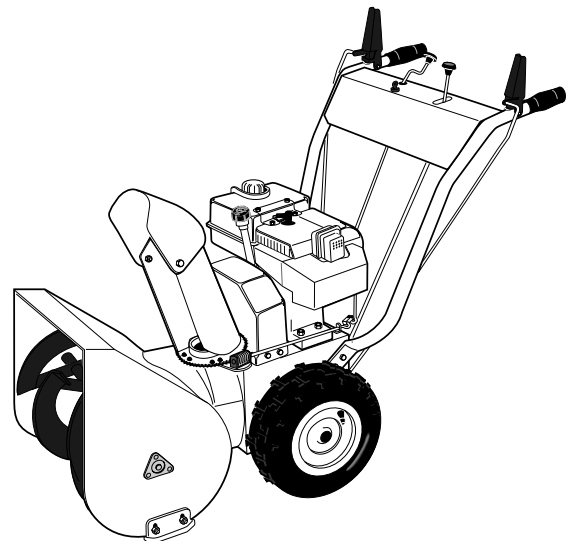

Dear Owner:

Thank you for purchasing this product. The unit was carefully designed and manufactured to provide excellent performance if properly operated and maintained.

Read this manual. This is a safety, operation and general maintenance manual which does not attempt to cover major repairs. This manual is considered a permanent part of the unit and it must stay with the unit if it is resold. A replacement manual can be obtained from the factory. All information in this manual is based on the latest product information available at the time of printing. Review this manual frequently to familiarize yourself with the unit, its features and safe operation.

Our products have met the rigid safety standards of the Outdoor Power Equipment Institute and an independent testing laboratory.



The warranty statement is included in the literature package. Read it carefully. Also, please complete and return the postpaid owner registration card included with this manual. The purpose of the card is to register each unit and owner at the factory to provide information and safety literature.

If you have any problems or questions concerning the unit, contact your local authorized dealer or the factory (our telephone numbers and mailing address are listed on page 3 and on the back of this manual).

We want to ensure your complete satisfaction at all times.



WARNING:

The engine exhaust from this product contains chemicals known to the State of California to cause cancer, birth defects or other reproductive harm.

Safety Alert Symbol



This is a safety alert symbol. It is used in this manual and on the unit to alert you to potential hazards. When you see this symbol, read and obey the message that follows it. Failure to obey safety messages could result in personal injury or property damage.

Owner Registration Card

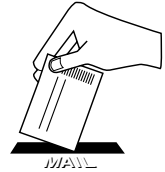

Please fill out and mail the enclosed Owner Registration Card. The purpose of this card is to register each unit and owner at the factory to provide information and safety literature.

Warranty Service

The warranty statement is included in your unit's literature package.

Model/Serial Numbers

The model/serial numbers are located on the back of the unit. For quick reference, record these numbers in the spaces below.

Date of Purchase:

Model/Serial Numbers:

Left and Right Sides

Left and right sides of the unit are determined from the operator position, facing the direction of forward travel.

Customer Service and Technical Service

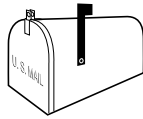

If you have questions or problems with the unit, contact your authorized dealer or call or write the factory. (When calling or writing the factory, provide the model/serial numbers of the unit.)



Replacement Parts

Factory specified replacement parts are available from either your authorized dealer or directly from the factory. For parts ordering information, refer to the parts catalog.

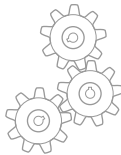

Engine Service and Repair

For engine service or repair, contact your nearest authorized engine dealer. To locate your nearest engine dealer, look in the Yellow Pages under "Engines—Gasoline." The engine on the unit is warranted by the engine manufacturer. Any unauthorized work performed on the engine during the warranty period may void the warranty. For complete details on the engine warranty, refer to the engine owner manual.

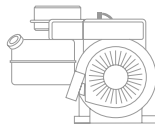

To Contact the Factory:

Garden Way Incorporated
1 Garden Way
Troy, New York 12180

Customer Service: 1-800-437-8686
Technical Service: 1-800-520-5520
Parts Service: 1-800-648-6776
FAX: (518) 391-7332

Outside the U.S.A. and Canada:

Customer Service: (518) 391-7007
Technical Service: (518) 391-7008
Parts Service: (518) 391-7006
FAX: (518) 391-7332

Table of Contents

SECTION 1: SAFETY	4
Safety Decals	7
SECTION 2: ASSEMBLY	8
Inspect Unit/Tools Required/Unpacking/Hardware Bag Contents	8
Install Handlebars.....	9
Install Discharge Chute/Attach Chute Control Rod	10
Attach Auger Drive Control Rod	11
Install Wheel/Gear Shift Control Rods	12
Install Wiring Harness/Adding Oil to the Engine/Check Gear Case Oil	13
Check Tire Pressure/Install (optional) Drift Slicers	13
SECTION 3: CONTROLS	14
Wheel/Auger/Gear Shift Control Levers	14
Discharge Chute Controls/Ignition Keyswitch/Fuel Shut-Off Valve	14
Engine Throttle/Primer	15
Engine Starter/Choke	15
Skid Shoes/Scraper Blade/Handlebar Warmer	15
SECTION 4: OPERATION	16
Pre-Operation Checklist	16
Starting the Engine	18
Stopping the Engine	18
Auger Drive Engagement/Disengagement	19
Wheel Drive Engagement/Disengagement	19
Shifting Gears.....	19
Transporting the Unit/Snowthrowing Patterns	20
SECTION 5: MAINTENANCE	21
Engine	21
Lubrication	22
Wheel Drive	23
Shear Bolts	23
Auger Drive	24
Slip Differential	25
Gear Shift Rod	25
Drive Disk Clearance.....	25
Brake Arm Adjustment	26
Skid Shoes/Scraper Blade	26
Off-Season Storage	26
Troubleshooting Chart	27
Maintenance Schedule.....	29
Specifications	30
Wiring Diagram	31

Section 1 Safety

SPARK ARRESTER WARNING TO RESIDENTS OF CALIFORNIA AND SEVERAL OTHER STATES

Under California law, and under the laws of several other states, you are not permitted to operate an internal combustion engine using hydrocarbon fuels on any forest, brush, hay, grain, or grass covered land; or land covered by any flammable agricultural crop without an engine spark arrester in continuous effective working order.

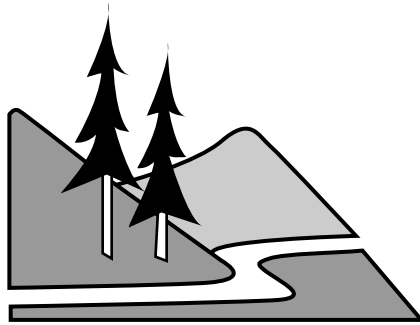

The engine on the unit is an internal combustion engine which burns gasoline, a hydrocarbon fuel, and must be equipped with a spark arrester muffler in continuous effective working order. The spark arrester must be attached to the engine exhaust system in such a manner that flames or heat from the system will not ignite flammable material. Failure of the owner/operator of the unit to comply with this regulation is a misdemeanor under California law (and other states) and may also be a violation of other state and/or federal regulations, laws, ordinances or codes. Contact your local fire marshal or forest service for specific information about which regulations apply in your area.

Training



1. Read this owner/operator manual and the separate engine owner manual carefully before operating the unit. Be completely familiar with the controls and the proper use of the unit. A replacement manual is available by contacting the factory.
2. Never allow children or untrained adults to use the unit.
3. Keep the area of operation clear of all people, particularly small children and pets. Keep bystanders at least 25 feet away from the area of operation.
4. Familiarize yourself with all of the safety and operating decals on the unit and on any attachments or accessories.
5. Do not run the engine in an enclosed area. Engine exhaust contains carbon monoxide gas, a deadly poison that is odorless, colorless, and tasteless. Do not operate the unit near buildings, windows, or air conditioners.
6. Keep hands or any other part of the body or clothing away from the inside of the auger housing, discharge opening, or moving parts.
7. Before inspecting, servicing or adjusting any part of the unit, shut the engine off, wait for all moving parts to stop, and disconnect the spark plug wire from the spark plug. Secure the wire away from the spark plug.
8. Do not operate the unit if you are under the influence of alcohol, medication, or when tired or ill.

Preparation

1. Wear approved safety glasses or eye shields and hearing protection when operating the unit. The operation of any powered machine can result in foreign objects being thrown by high-speed rotating parts.
2. Do not wear loose-fitting clothing, such as scarves, which could be caught by moving parts. Tie up or restrain long hair.

3. Before starting the engine, check the tightness of all screws, nuts, bolts, and other fasteners. Replace or clean any damaged or unreadable safety and operating labels.
 4. Wear adequate winter outer garments when operating the unit. Wear footwear that will improve footing on slippery surfaces. Exercise caution to avoid slipping or falling, especially when operating in reverse.
 5. Use extra care when handling gasoline and other fuels. Gasoline and its vapors are highly flammable and explosive. To help prevent a fire or explosion:
 - a. Store gasoline only in an approved gasoline storage container, safely out of the reach of children.
 - b. Never remove the fuel fill cap on the fuel tank, or add fuel while the engine is running or hot.
 - c. Keep matches, smoking materials, open flames, and sparks away from the fuel tank and gasoline storage container.
 - d. Fill the fuel tank outdoors and with extreme care. Never fill the fuel tank indoors.
 - e. Replace the fuel fill cap on the fuel tank, the cap on the gasoline storage container, and clean up fuel spills before starting the engine.
 - f. Leave 1/2-inch (2.5 cm) of air space at the top of the fuel tank to allow for fuel expansion.
 - g. Do not store the unit or the gasoline storage container where there is a danger of an open flame or spark, or where ignition sources are present such as hot water and space heaters, furnaces, clothes dryers, stoves, electric motors, etc.
 6. For units equipped with the electric-start kit:
 - a. Only use a 3-pronged, UL rated and approved, outdoor use electrical cord.
 - b. Only plug into a properly grounded, 3-pronged outlet. Do not use any adapters on the cord.
 - c. Inspect the electrical cord for damage before use. If it is damaged, do not use it.
 - d. Stand on dry ground when handling the electrical cord. Do not handle the electrical cord with wet hands or wet gloves. Do not use the electric starter if it is raining.
 - e. Connect the cord to the electric starter first, and then plug the cord into a properly grounded outlet (this lessens the chances of sparks from occurring near the engine).
 - f. Do not abuse the electrical cord. Do not pull the unit by the cord. Do not pull the cord to disconnect it from the outlet. Keep the cord away from sharp edges, oil, and excessive heat.
 7. Adjust the skid shoes and scraper blade so the auger housing clears gravel or crushed rock surfaces.
 5. Check the operation of the controls before using the unit. Do not operate the unit unless all controls are operating properly.
 6. Never carry passengers on the unit. They could fall off and be seriously injured, or they could interfere with safe operation.
- 
7. Keep hands, other body parts, and clothing away from any moving or rotating parts. Keep clear of the intake and discharge openings at all times.
 8. Before starting the engine, inspect the area where the unit is to be used and remove all sleds, boards, doormats, metal, bottles, cans, or other debris.
 9. Keep children out of the area of operation and under the watchful eye of an adult not operating the unit. Never assume that children will remain where you last saw them.
 10. If the unit makes an unusual noise or vibration, immediately shut the engine off, wait for all moving parts to stop, disconnect the spark plug wire from the spark plug and perform the following steps:
 - a. Inspect for damage.
 - b. Replace or repair any damaged parts.
 - c. Check for and tighten any loose parts.

Operation

1. The operator of the unit is responsible for the safety of all persons in the operating zone of the unit.
2. Before starting the unit, disconnect the spark plug wire and check the auger and discharge chute to make sure they are free of ice. Check the engine oil level. Reconnect the spark plug wire before starting the engine.
3. Disengage all clutches and shift into neutral before starting the engine.
4. Let the unit adjust to outdoor temperature before use.

Section 1: Safety

11. Before inspecting the unit or making any adjustments, or if the unit jams or becomes clogged, shut the engine off immediately and allow all moving parts to come to a stop. Disconnect the spark plug wire from the spark plug and secure the wire away from the spark plug. Use only a wooden stick (at least 3 feet long) to clear away any blockage.
12. Keep all guards, covers, shields and safety devices in place and in good working condition. Do not attempt to defeat the purpose of any safety device.
13. Exercise extreme caution on slopes.
14. Do not attempt to clear steep slopes.
15. Do not clear snow across the face of slopes. Exercise extreme caution when changing direction on slopes.
16. Always observe the terrain. Watch for and avoid obstacles. Stay away from holes, ditches, soft or steep embankments and other potentially dangerous terrain. Deep snow can hide obstacles and drop-offs.
17. Do not use the unit near drop-offs, ditches, or embankments. If a wheel goes over an edge, or if an edge caves in, the unit could overturn.
18. Do not operate the unit at high transport speeds on slippery surfaces. Wet surfaces reduce traction and stability.
19. Look behind and use care when operating the unit in reverse. If you have to pull the unit backward, disengage the auger and wheel drives. Always check behind you for hazards.
20. Be extremely careful when using the unit near blind corners, shrubs, trees, and other objects that may obscure vision.
21. Be extremely careful when operating near or crossing gravel drives, walks or roads. Stay alert for hidden hazards or traffic.
22. Remove any hearing protection and watch for traffic when operating near, or when crossing roadways.
23. Do not leave the unit unattended with the engine running. Stop the engine, let all moving parts come to a stop, and disconnect the spark plug wire from the spark plug before leaving the unit.
24. Use only attachments and accessories that are approved for use with the unit. Contact the factory customer service department, at the address and phone number on page 3, if you are not sure about the use of any attachment or accessory.
25. Operate the unit only in daylight or in good artificial light.
26. Do not tamper with the engine governor settings. The governor controls the maximum safe engine operating speed and protects the engine and moving parts from damage. Contact your local engine dealer for service if a problem exists.
27. Shut off the engine, disconnect the spark plug wire and secure the wire away from the spark plug, before transporting the unit in a vehicle.
28. Do not touch the muffler or other engine parts which may be hot from operation. Wait for parts to cool completely before inspecting, cleaning, or repairing the unit.
29. Never operate the unit near buildings, glass enclosures, automobiles, window wells, drop-offs, etc., without first properly adjusting the discharge angle and direction. Keep children and pets away.
30. Never direct discharge at persons, animals, vehicles or buildings. Never allow anyone in front of the unit when the engine is running.
31. Disengage the auger drive when the unit is being transported or is not in use.
32. Disengage the auger and wheel drives if you are approached by any child, inattentive person or pet.
33. Run the unit for a few minutes after use to prevent freeze-up. Remove any snow from the unit (snow can melt, re-freeze, and jam the unit).

Maintenance and Storage

1. When the unit is stopped for servicing, inspection, storage, or to change an attachment or an accessory, disconnect the spark plug wire from the spark plug and secure the wire away from the plug. Let the engine cool before making inspections, adjustments, or performing any maintenance.
2. Maintain the unit and all attachments and accessories in safe working condition.
3. Never perform any maintenance while the engine is running, or when the spark plug wire is connected to the spark plug.
4. Do not store the unit or fuel container inside an enclosure where there is an open flame or spark, or where ignition sources are present, such as: hot water and space heaters, furnaces, clothes dryers, stoves, electric motors, etc.

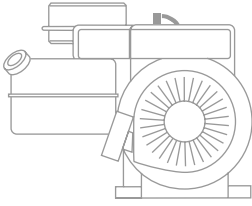

Safety Decals

For your personal safety and the safety of others, a number of safety message decals have been affixed to your unit. Keep them clean and legible at all times. Contact your local service dealer or the factory for replacements if any decals are damaged or missing.

Refer to the separate parts catalog for decal locations, part numbers, and ordering instructions.

5. Allow the engine to cool before storing in any enclosure.
6. Store gasoline in a cool, well-ventilated area, safely away from any spark- or flame-producing equipment.
7. Store gasoline only in an approved gasoline storage container, safely out of the reach of children.
8. Use only original equipment replacement parts. Parts manufactured by others could present a safety hazard even though they may fit on the unit.
9. Store the unit where children will not have access to it. Always disconnect the spark plug wire from the spark plug to prevent accidental starting. Remove the ignition key from the ignition keyswitch.
10. Check the tightness of the auger shear bolts and other fasteners at frequent intervals. Torque shear bolts to 11 ft. lbs. (15 Nm).
11. Maintain or replace safety and instruction decals as needed if they are damaged or illegible. Refer to the parts catalog for decal location and ordering information.
12. Refer to the engine owner manual for complete engine information.

Section 2 Assembly

IMPORTANT: Follow the assembly steps carefully. Contact the factory or your local authorized dealer if you have any questions or problems.

A. Inspect Unit

Inspect the unit and shipping crate for damage immediately after delivery. Contact the carrier (trucking company) if you find or suspect damage. Inform them of the damage and request instructions for filing a claim. To protect your rights, put your claim in writing and mail a copy to the carrier within 15 days after the unit has been delivered. Contact the factory as indicated on page 3 of this manual if you need assistance.

B. Tools/Materials Required for Assembly

- (1) Crowbar or large screwdriver (to disassemble wood crate)
- (1) Scissors or knife (to cut plastic ties)
- (1) *5/16" wrench
- (1) *3/8" wrench
- (2) *7/16" wrenches
- (2) *1/2" wrenches
- (1) *9/16" wrench
- (1) Phillips head screwdriver (medium)
- (1) Needle-nosed pliers (medium)
- (1) Automotive-type tire pressure gauge
- (1) Funnel
- (1) Clean, high-quality motor oil. Refer to the separate engine owner's manual for the exact oil specifications and amount needed for your engine.

* Adjustable wrenches may be used.

IMPORTANT: Motor oil must be added to the engine crankcase before the engine is started. Follow the instructions in this "Assembly" section.

C. Unpacking Instructions

The shipping crate should contain:

- Snowthrower/engine/auger assembly
 - Handlebar assembly
 - Discharge chute assembly
1. Remove top and sides of wood crate.
 2. Remove discharge chute assembly (with attached hardware bag) from inside cardboard sleeve. Remove cardboard sleeve.
 3. Remove the hex nut (A, Fig. 2-1) and the shipping strap from the left side skid shoe. Reinstall the hex nut, tightening it securely.
 4. Remove the screw (B, Fig. 2-1) and the shipping strap from the rear cover on the right side of the unit. Reinstall the screw, tightening it securely.
 5. The unit is heavy. **Use caution and obtain the help of at least one assistant.** Carefully remove the unit from the crate by rolling the unit off the platform. Park the unit on a clean, level surface.

D. Hardware Bag Contents

The hardware bag should contain the items listed below and shown in Fig. 2-2:

Ref.	Description	Qty.
A	Cable tie	3
B	Hex hd. flange screw, 3/8-16 x 3/4	4
C	Hex hd. screw, 1/4-20 x 3/4.....	2
D	Locknut, 1/4-20	2
E	Phillips hd. screw, #10-24 x 3/8 ...	2
F	Locknut, #10-24	2
G	Cotter pin	1
H	*Shear bolt, 5/16-18 x 1-3/4	2
I	*Locknut, 5/16-18	2
J	Ignition key.....	2
--	Grease Tube (not illustrated). For maintenance use if required.....	1

*These items are extra auger shear bolts and locknuts (if the auger catches a hard obstruction, the shear bolts are designed to break to prevent damage to the auger and other parts). See the "Maintenance" section for replacement steps.

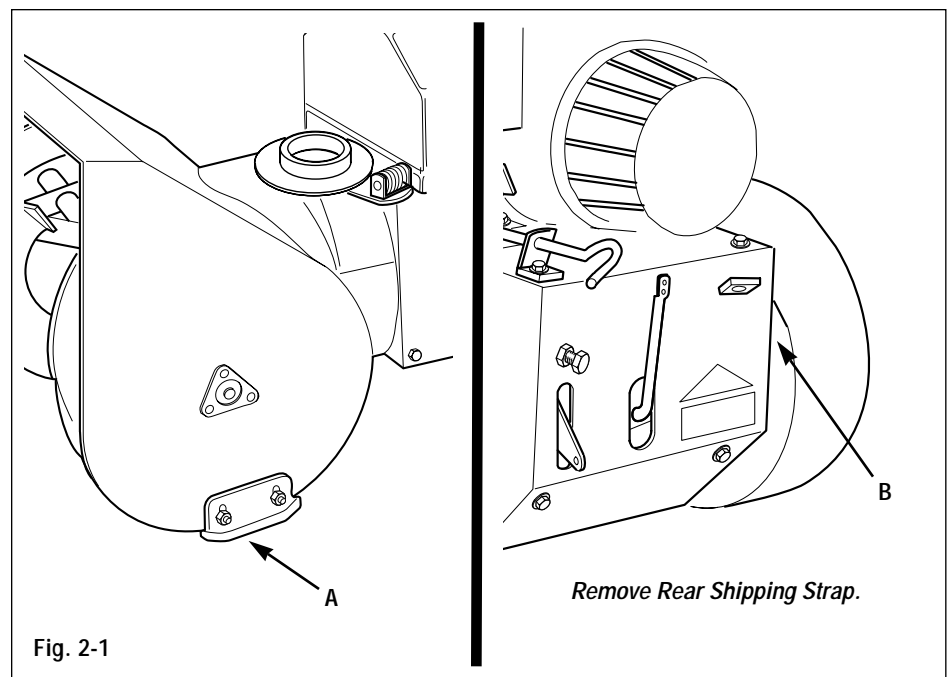
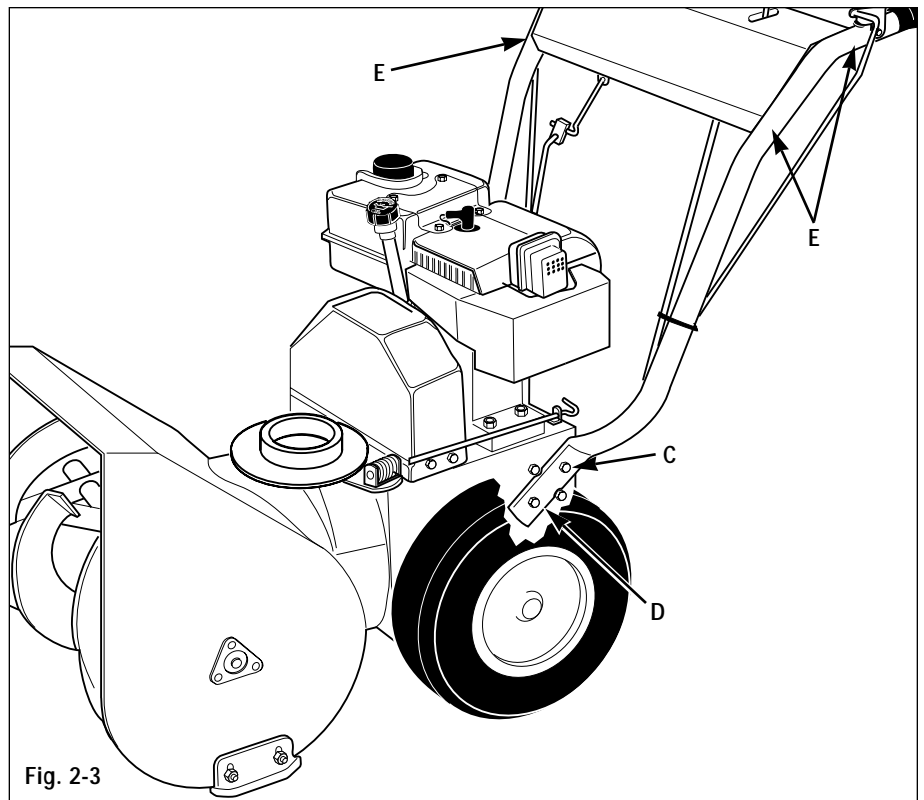
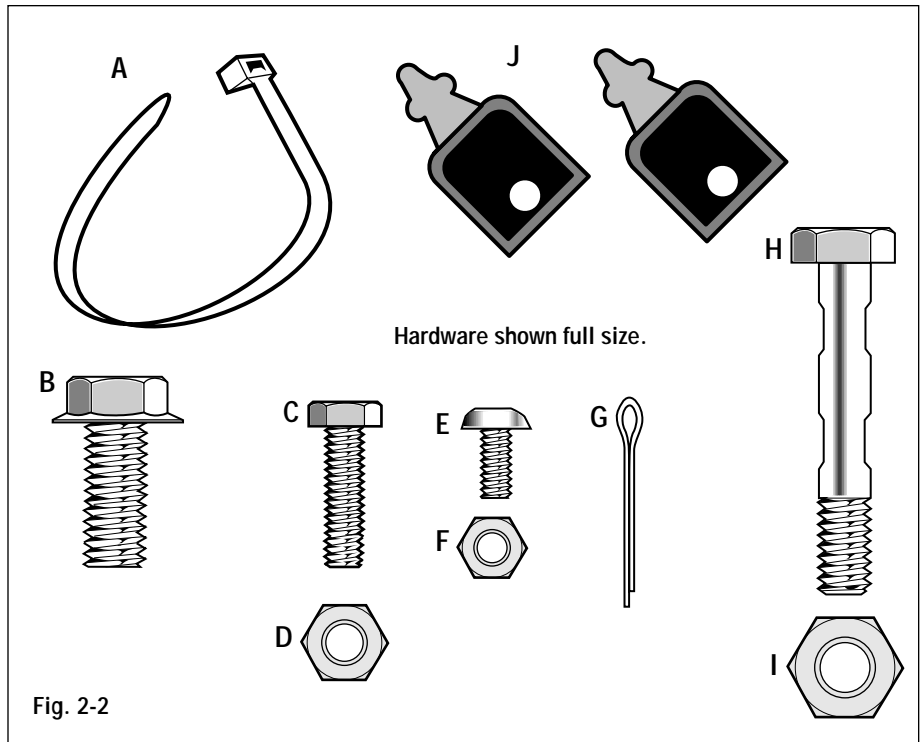

Fig. 2-1

IMPORTANT: Left and right sides of the unit are determined from the operator position, facing the direction of forward travel.

E. Install Handlebars

1. Cut the plastic cable ties securing the handlebar ends to the chassis and remove the handlebars. Remove the protective wrapping on the handlebars.
2. Attach the handlebars to the sides of the chassis as follows (use the four 3/8-16 x 3/4" hex flange screws supplied in hardware bag):
 - a. Install two screws in the upper mounting holes (C, Fig. 2-3) on each side. Leave screws loose enough to allow handlebar to pivot.
 - b. Install two screws (D) in the lower mounting holes.
 - c. Using light pressure, press down on the left side handlebar and tighten the two screws. Repeat on the right side handlebar.
3. There are four pre-installed screws (E, Fig. 2-3) on the inside of the handlebars that secure the control panel to the handlebars. Check each screw and tighten securely.



Section 2: Assembly

F. Install Discharge Chute

1. Remove the cardboard packing shield from the discharge chute mount opening.
2. Loosen (do not remove) the left and right side sets of plastic shims (G, Fig. 2-4, inset A) and plastic hold-down clips (H, Fig. 2-4, inset A) on the toothed flange (J) of the discharge chute assembly. Remove and save the remaining (front) hold-down clip, shim and mounting hardware.
3. From either side of the unit, slide the discharge chute onto the chute mounting flange (K), making sure that the plastic shims (G) are above the flange and the plastic hold-down clips (H) are below the flange. Tighten the shim mounting hardware securely (if necessary, rotate the discharge chute to the right in order to tighten the left side shim and hold-down clip).
4. Hook the front hold-down clip (H) under the mounting flange (K) and place the front plastic shim (G) on top of the hold-down clip, between the top of the flange and the toothed chute flange. Using two 5/16" wrenches, secure with the screws, washers and locknuts.
5. Remove the plastic cable tie that secures the worm gear assembly (L, Fig. 2-4 inset B) to the mounting bracket.
6. Remove the washer and locknut from the screw (M, Fig. 2-4 inset B) in the worm gear assembly (L). Position the worm gear assembly on the mounting bracket as follows:
 - a. Engage the worm gear threads 1/2-way with the teeth on the flange of the discharge chute base (rotate chute as needed).
 - b. The length of the worm gear should be centered with the teeth on the flange of the discharge chute base.
 - c. Reinstall the washer and locknut on the screw (M) and tighten securely.

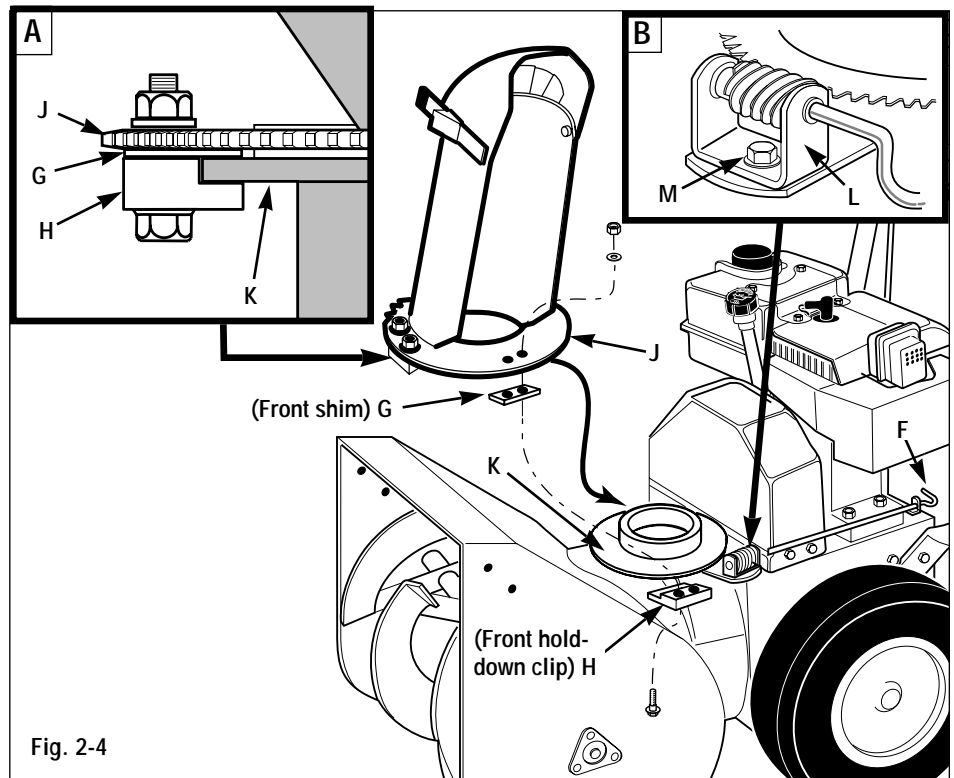

Fig. 2-4

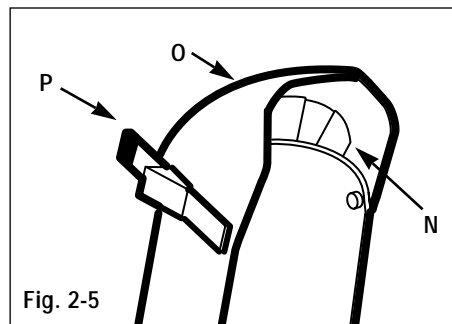

Fig. 2-5

- d. Turn chute control rod (F, Fig. 2-4) by hand to be sure the worm gear and discharge chute rotate freely, but with enough resistance to prevent free rotation of the discharge chute during snow removal operation. Readjust position of worm gear assembly as necessary.
7. Insert the flexible fingers on the plastic snow deflector (N, Fig. 2-5) inside the chute deflector cap (O). Close the deflector cap by pulling the lever (P) outward and moving the deflector cap down. Release the lever to secure the deflector cap in one of the discharge angle selector holes.

G. Attach Chute Control Rod

1. Remove the plastic cable tie that secures the auger drive control rod (AA, Fig. 2-6) to the right handlebar. Next, remove the plastic cable tie that secures the chute crank rod (short rod with plastic swivel blocks) to the auger drive control rod.
2. Pull the chute crank rod (Z, Fig. 2-6) up through the top of the control panel.
3. Attach the chute control rod sections (S and U, Fig. 2-6) as follows:
 - a. Insert the angled end of the chute control rod, (U, Fig. 2-6 inset) into the hole in the swivel block (V) that is attached to the end of the chute crank rod (S).
 - b. Insert a cotter pin (W) through the hole in the chute control rod (U) and spread the ends of the cotter pin.
4. Position the chute control support (Y, Fig. 2-7) against the underside of the handlebar console as shown. Secure the support with the two #10-24 x 3/8" Phillips pan head screws and #10-24 locknuts supplied.

Section 2: Assembly

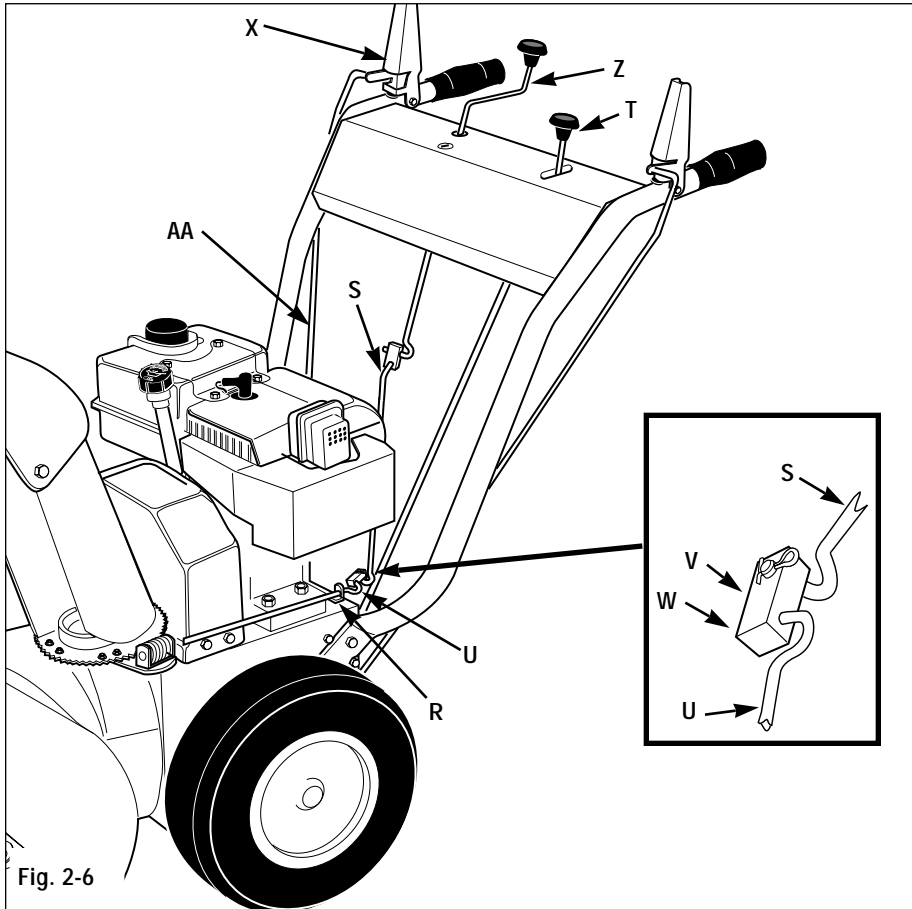

Fig. 2-6

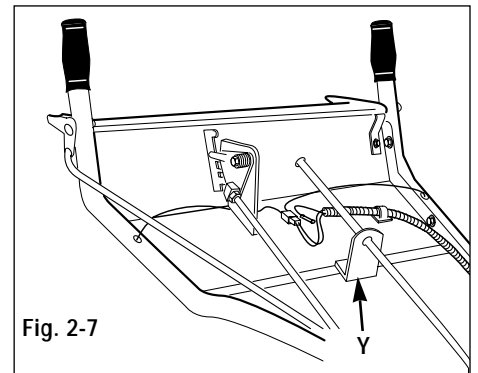

Fig. 2-7

5. Rotate the chute control crank (Z, Fig. 2-6). The deflector chute should turn freely. Adjust the worm gear assembly bracket (L, Fig. 2-4) as necessary to prevent binding.

H. Attach Auger Drive Control Rod

1. Remove the plastic cable tie that secures the auger drive control arm (AD, Fig. 2-8) to the transmission shift arm (AB).
2. The auger drive control rod (AA, Fig. 2-8) has been pre-adjusted at the factory. To avoid misadjustment, do not rotate the jam nut (AT, Fig. 2-8) while completing the following steps.
3. Hold the jam nut (AT) in place with a 7/16" wrench and use another 7/16" wrench to thread the adjusting thimble (AS) downward a total of 12 turns.
4. Raise auger drive control handle (X, Fig. 2-6) all the way up. Then hook the spring (AC, Fig. 2-8) at the lower end of the auger drive control rod (AA) into the hole in the auger drive control arm (AD).
5. Thread the adjusting thimble (AS, Fig. 2-8) upward until it contacts the jam nut (AT). Using two wrenches, tighten the jam nut against the adjusting thimble. When the engine is started, as described in the "Operation" section, you will be given a functional check to make sure the auger drive control rod is properly adjusted.

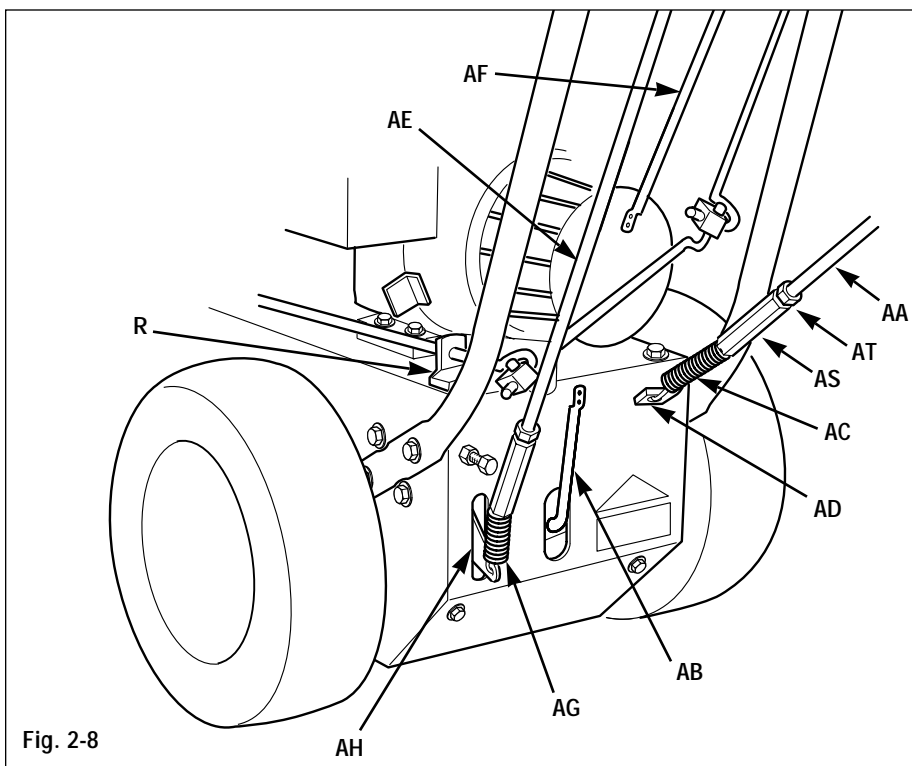
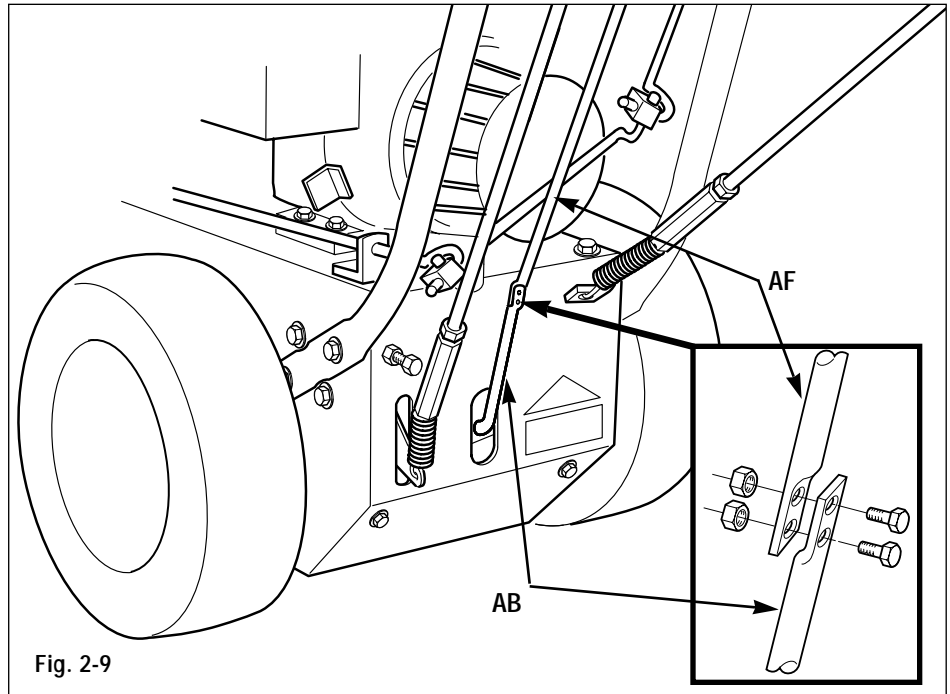

Fig. 2-8

Section 2: Assembly

I. Attach Wheel Drive Control Rod

1. Remove the plastic cable tie that secures the wheel drive control rod (AE, Fig. 2-8) and the gear shift control rod (AF) to the left handlebar.
2. Hook the spring (AG, Fig. 2-8) at the lower end of the wheel drive control rod (AE) into the hole in the wheel drive control arm (AH). If necessary, raise the wheel drive control arm (AH) while attaching the spring.
3. The wheel drive control rod has been pre-adjusted at the factory. When the engine is started, as described in the "Operation" section, you will be given a functional check to make sure the wheel drive control rod is properly adjusted.



J. Install Gear Shift Control Rod

1. Place the gear shift select lever (T, Fig. 2-6) in the No. 5 position.
2. Gently push the transmission shift arm (AB, Fig. 2-9) fully downward.
3. Align the holes in the transmission shift arm (AB) and the lower end of the gear shift control rod (AF). If the holes do not align, follow the "Gear Shift Rod Adjustment" procedure in the "Maintenance" section of this manual.
4. Attach the gear shift control rod (AF) to the transmission shift arm (AB) with the two 1/4-20 x 3/4 hex head screws and 1/4-20 locknuts supplied (see Fig. 2-9).

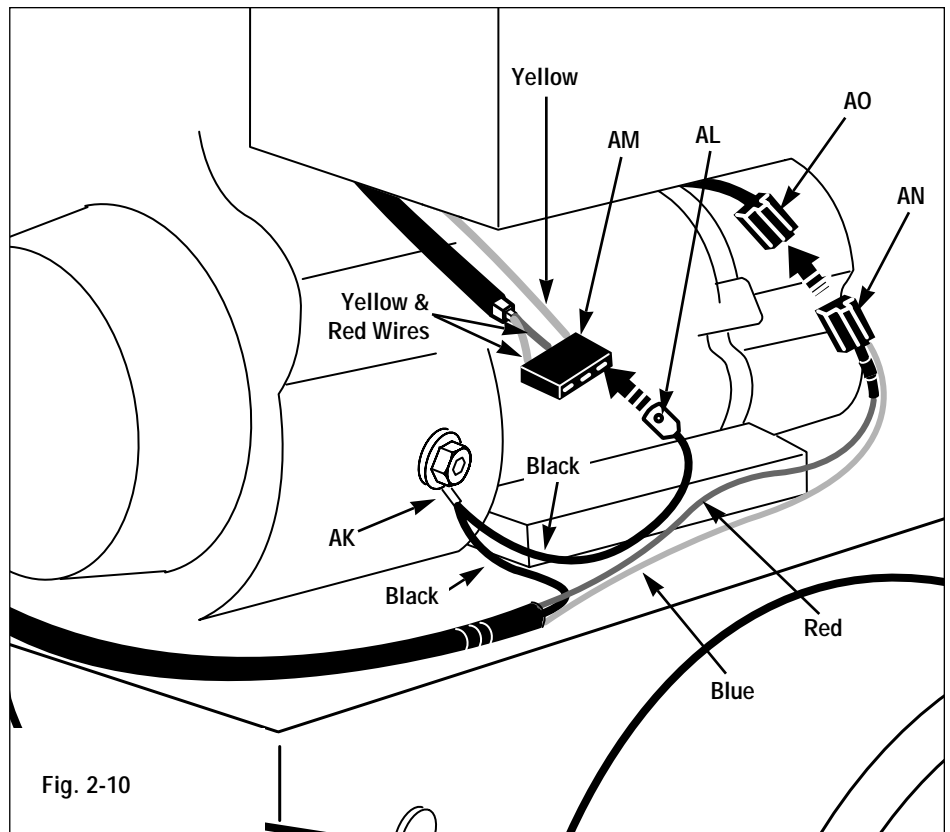

K. Wiring Harness Installation

1. Remove the plastic cable tie that secures the wiring harness to the right handlebar.
2. Route the wiring harness to the inside of the right handlebar and over to the right side of the engine.
3. Attach the ring terminal (AK, Fig. 2-10) on the two black wires to the screw on the engine shroud as shown. The lockwasher should be next to the screw head and the ring terminal in between the lockwasher and the engine shroud.
4. Connect the spade terminal (AL, Fig. 2-10) on the black wire to the yellow wire receptacle inside the connector receptacle (AM). Note that there are *two* yellow wires extending out of the back of the receptacle (AM). *Do not install the spade terminal (AL) into the receptacle for the yellow wire that is attached with a small plastic connector to the red wire.*
5. Plug the wiring harness connector (AN) into the engine connecting plug (AO). Note that it can only be plugged in one way.
6. Using two of the plastic cable ties provided, loosely (to avoid stretching wires) attach the upper section of the wiring harness to the right handlebar. Use the third cable tie to loosely tie the black, blue and red wires together at the side of the engine. Be sure that the wires are positioned safely away from the wheel.

L. Add Engine Oil to Crankcase

WARNING

DO NOT START ENGINE UNTIL ENGINE CRANKCASE HAS BEEN FILLED WITH OIL. FAILURE TO FOLLOW THIS INSTRUCTION WILL RESULT IN SERIOUS ENGINE DAMAGE.

1. Be sure that the engine is level before checking or adding oil.
2. To add engine oil, unscrew dipstick (AP, Fig. 2-11). Fill oil at the dipstick opening with fresh oil. See the engine owner manual for correct oil specifications and quantity required. Do not use SAE 10W40.
3. Oil level on dipstick should always be above "ADD" and below "FULL". Wait a few minutes after filling crankcase, allowing oil to settle. Insert dipstick and tighten securely. Recheck level and adjust as necessary.

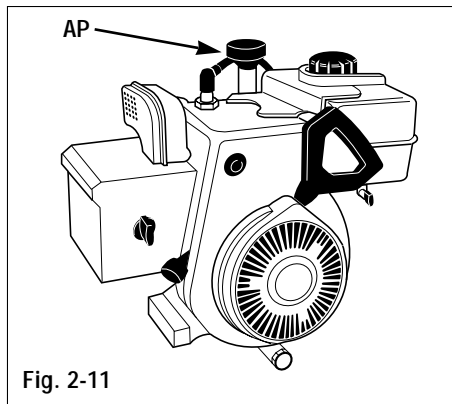

Fig. 2-11

M. Check Auger Gear Case Oil Level

The auger gear case was filled at the factory with the correct amount of SAE 90 gear oil. This level should be checked before using the unit. Refer to "Lubrication" in the Maintenance section of this manual for complete information.

N. Check Tire Pressure

Check the air pressure in both tires using an automotive-type tire pressure gauge. Inflate tires evenly to 8-12 psi (55-82 kPa).

O. Install Drift Slicers (optional attachment)

The optional drift slicers (AR, Fig. 2-12) are designed for use in deep snow conditions. To install the drift slicers:

1. Position the drift slicers (AR, Fig. 2-12) to the **outside** of the auger housing.
2. Attach the drift slicers with the four 5/16-18 x 3/4 screws and locknuts (AS) provided with the drift slicers.

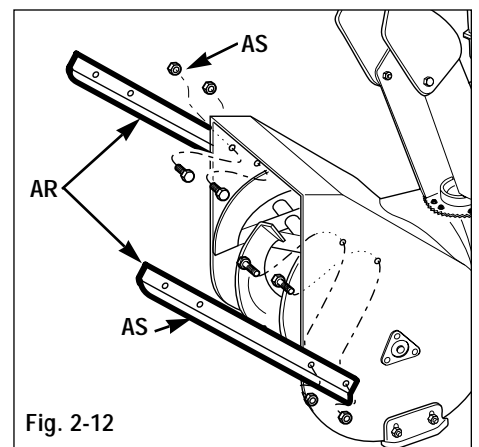

Fig. 2-12

Section 3 Controls

This section defines the various controls on the unit. Refer to the following section, "Operation," for an explanation of the proper use of these controls.

A, Fig. 3-1—Wheel drive control lever

Controls the engagement of the wheel drive. When this lever is down against the handlebar and the engine is running, the wheels will rotate. Refer to the "Maintenance" section of this manual for the proper adjustment information.

B, Fig. 3-1—Auger drive control lever

Controls the engagement of the auger drive. When this lever is down against the handlebar and the engine is running, the auger will rotate. Refer to the "Maintenance" section of this manual for the proper adjustment information.

C, Fig. 3-1—Gear shift control lever

Controls the selection of travel speeds: five forward and two reverse positions. Refer to the "Maintenance" section of this manual for the proper adjustment information.

D, Fig. 3-1—Discharge chute control rod

Controls the direction the discharge chute is facing. Rotate this crank clockwise to turn the discharge to the right; rotate counter-clockwise to turn the discharge chute to the left. Approximately ten turns of this crank will move the discharge chute all the way from one side to the other.

E & F, Fig. 3-2—Discharge chute deflector cap and lever

Controls the vertical angle of the snow discharge. To adjust the discharge angle: move the discharge cap by pulling lever (F, Fig. 3-2) outward and moving the discharge deflector cap up or down. The discharge chute deflector cap should usually be adjusted to a low angle, especially in windy conditions.

G, Fig. 3-1—Ignition keyswitch

The keyswitch has two positions: "Ⓜ" RUN and STOP. Rotating the key to the "Ⓜ" RUN position allows the engine to be started. Rotating the key to the STOP position stops the engine. Always remove the ignition key when the unit is not in use. Store the key in a safe place out of the reach of children.

Fig. 3-3—Fuel shut-off valve

Located beneath the fuel tank, the fuel shut-off valve (Fig. 3-3) controls fuel flow from the fuel tank to the carburetor. Refer to the engine owner manual for complete information.

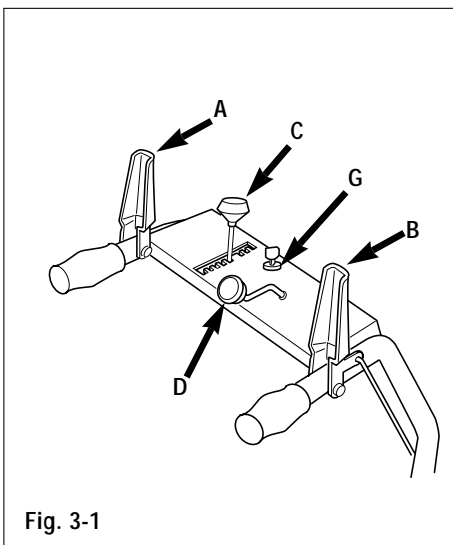

Fig. 3-1

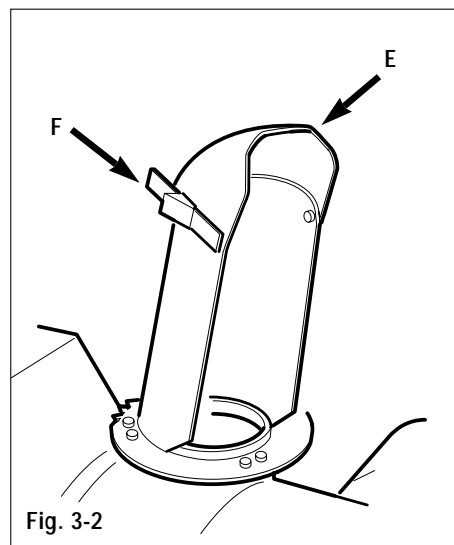

Fig. 3-2

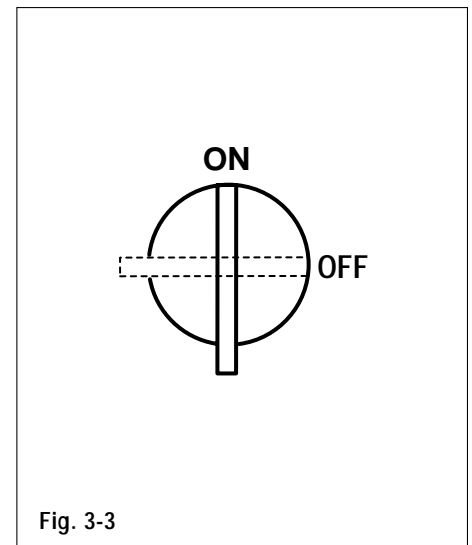

Fig. 3-3

H, Fig. 3-4—Throttle

Located on back left corner of the engine, the throttle controls the speed of the engine. For proper operation information, refer to the following section, "Operation."

NOTE: *The engine lubrication and cooling systems operate best at full throttle. Operating the engine at less than full throttle for extended periods can adversely affect the performance of this system.*

J, Fig. 3-4—Primer button

Located at the back upper left corner of the engine. Pressing the primer button pumps small amounts of gasoline into the engine to improve cold weather starting. Refer to the following section, "Operation," for proper operation information.

K, Fig. 3-4—Recoil starter

Located on the back of the engine, the engine recoil starter is used to pull-start the engine. Refer to the following section, "Operation" for proper operation information.

L, Fig. 3-4—Choke knob

Controls the amount of gasoline in the air/gasoline mixture that is fed into the engine. This is known as "choking" the engine. It is often necessary to "choke" a cold engine when starting. Refer to the following section, "Operation," for proper operation information.

M, Fig. 3-5—Skid shoes

Controls the distance between the auger housing/scrapper blade and the ground. This distance should be adjusted to clear any uneven or gravel surfaces. Refer to the "Maintenance" section for proper adjustment information.

N, Fig. 3-5—Scraper blade

Located at lower front bottom edge of the auger housing, the scraper blade is designed to contact the ground and to clear snow down to the pavement. Refer to the "Maintenance" section for proper adjustment information.

Handlebar Warmer Feature

The unit is equipped with handlebar warmers that are automatically activated when the engine is running. Allow a few minutes (perhaps longer in extremely cold temperatures) for the handlebars to warm to the touch.

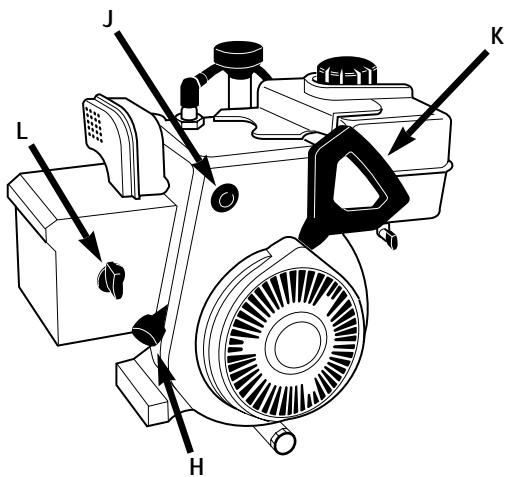

Fig. 3-4

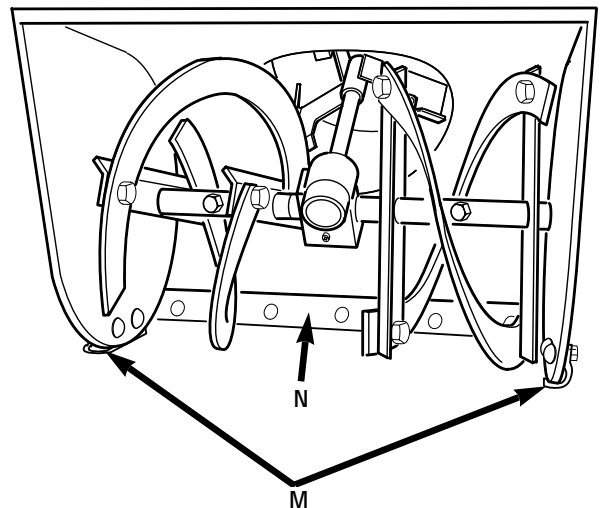

Fig. 3-5

Section 4 Operation

Pre-operation checklist

1. Review Section 1, "Safety" and Section 3, "Controls" in this manual.
2. Check the unit for any loose or missing hardware. Tighten or replace as needed.
3. Check inside the auger housing and the discharge chute and remove any debris.
4. Check the engine oil level:
 - a. Move the unit onto a level surface.
 - b. Remove the engine oil dipstick (O, Fig. 4-1).
 - c. Wipe the oil from the dipstick with a clean cloth.
 - d. Screw the dipstick back into the engine.
 - e. Remove the engine oil dipstick (O, Fig. 4-1) again.
 - f. The oil level should be between the "FULL" and the "ADD" marks on the dipstick. Refer to the engine owner manual for proper engine oil specifications.

WARNING

DO NOT START ENGINE UNTIL ENGINE CRANKCASE HAS BEEN FILLED WITH OIL. FAILURE TO FOLLOW THIS INSTRUCTION WILL RESULT IN SERIOUS ENGINE DAMAGE.

5. Remove the gasoline tank fill cap (A) and check the level of gasoline in the gasoline tank.

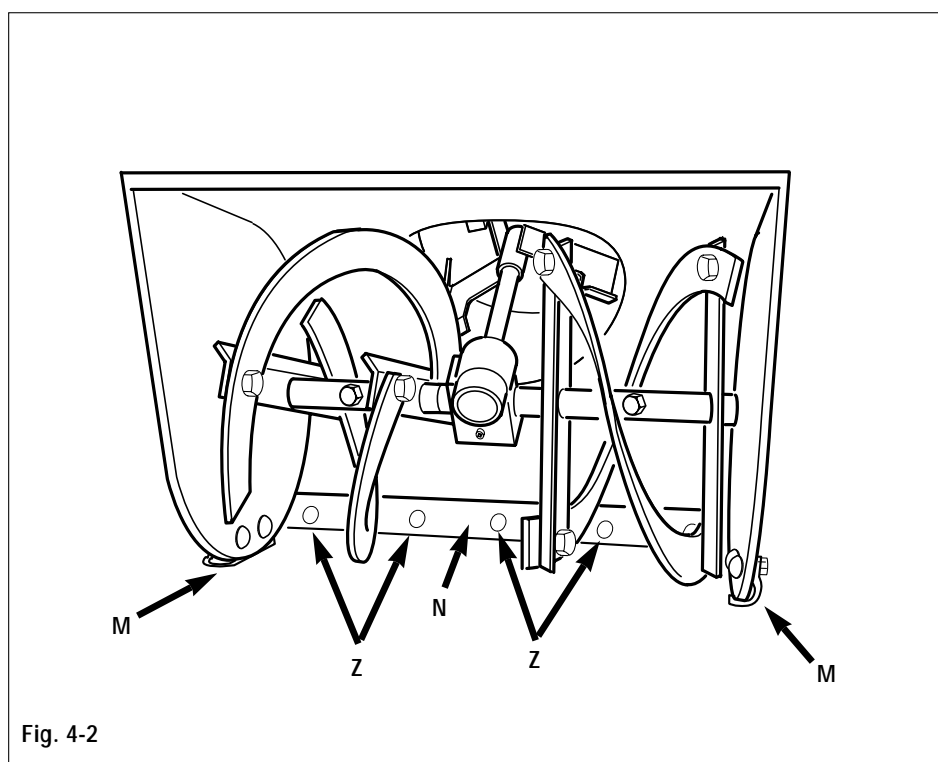
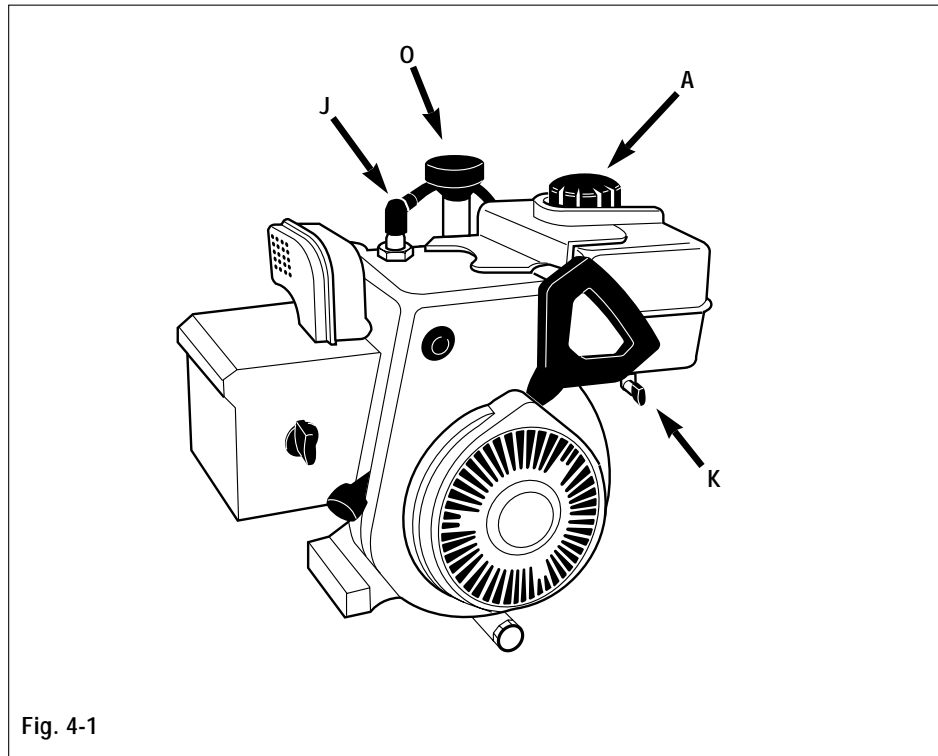

⚠ WARNING

GASOLINE IS HIGHLY FLAMMABLE AND ITS VAPORS ARE EXPLOSIVE. NEVER REMOVE THE GASOLINE TANK FILL CAP OR ADD FUEL WHEN INDOORS OR WHEN ENGINE IS RUNNING OR HOT. WIPE UP SPILLED GASOLINE IMMEDIATELY. KEEP SMOKING MATERIALS, SPARKS OR FLAMES FAR FROM FUEL TANK AND CONTAINERS.

Fill the fuel tank with fresh, clean unleaded gasoline with a minimum octane rating of 87. Leave 1/2" of space for fuel expansion. **DO NOT MIX OIL WITH GASOLINE!** Tighten the gasoline fill cap securely. Refer to the engine owner manual for additional gasoline information.

DO NOT MIX OIL WITH GASOLINE!

- The unit should be adjusted so the auger housing and the scraper blade (N, Fig. 4-2) are 1/8" above the surface to be cleared. If the unit is used to clear gravel or uneven surfaces, this adjustment should be increased so gravel or other foreign objects are not scooped up into the auger.

To adjust the auger housing/scraper blade height:

- Move the unit onto a level surface.
- Loosen the bolts securing the skid shoes (M, Fig. 4-2).
- Adjust the skid shoes (M) until they are in the correct position to support the auger housing and the scraper blade (adjust both skid shoes the same to prevent uneven snow removal).
- Tighten the bolts to lock the skid shoes (M) into the proper position.

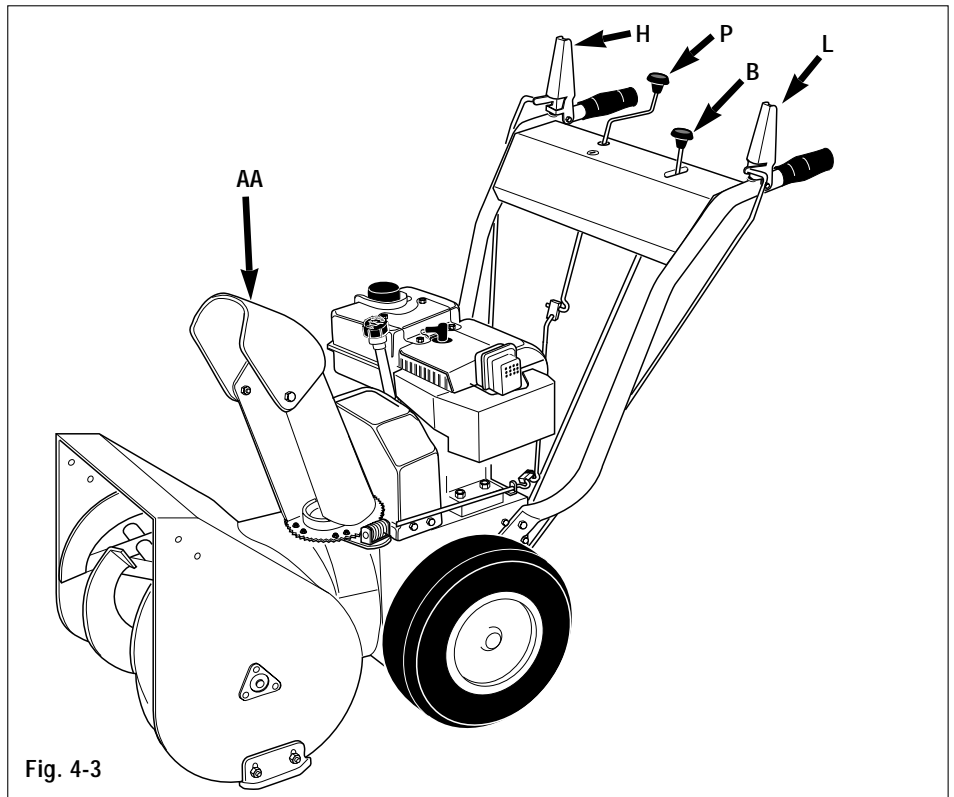



Fig. 4-3

- The scraper blade (N, Fig. 4-2) can also be adjusted. Adjust the scraper blade (N) at the carriage bolts (Z, Fig. 4-2). Adjust the bottom edge of the scraper blade so it is parallel to the bottom edge of the auger.
- Adjust the discharge chute deflector cap (AA, Fig. 4-3) with lever to the desired angle of discharge. Usually keep the angle of the discharge deflector cap low, especially in windy conditions.
- Rotate the discharge chute control rod (crank) (P, Fig. 4-3) and check for binding.
- Check the auger drive and wheel drive control levers (H and L, Fig. 4-3) for freedom of movement.
- Check the tire pressure. Inflate both tires evenly to 8 to 12 PSI (55 to 82 Kpa).
- Spray silicone spray on the inside of the deflector chute, the chute discharge deflector cap, the auger housing, and on the augers. This will help prevent snow from sticking (do not spray silicon spray on rubber or plastic: damage can result).
- Re-connect the spark plug wire (J, Fig. 4-1) to the spark plug if needed.
- Rotate the fuel shut-off valve (K, Fig. 4-1) to the "ON" position, if so equipped.

Section 4: Operation

Starting the engine

1. Review the "Pre-operation checklist" earlier in this section. Move the unit outside to a well-ventilated, level area.
2. Move the gearshift lever (B, Fig. 4-4) into the desired gear position.
3. Turn the ignition key (C, Fig. 4-4) to the RUN "Ⓜ" position.
4. Turn choke knob "N" (D, Fig. 4-5) clockwise to FULL CHOKE (warm engines require little or no choking). Push the primer button (E, Fig. 4-5) two or three times (cover hole in center of bulb when pushing). If the temperature is below 15° F (-9° C), push the button 4 or 5 times.
5. Move the throttle lever (F) to FAST .

To start engine with the recoil starter:

6. Before using the recoil starter (G, Fig. 4-5), make sure there are no obstacles behind you.
7. Pull recoil starter handle rapidly to overcome engine compression, prevent kick-back and start engine. Maintain control of rope so it slowly returns into the starter mechanism. Repeat pulling actions until engine starts.
8. Turn the choke knob "N" (D, Fig. 4-5) counterclockwise out of the full-choke position. Turn the choke off as the engine warms up.

WARNING

DO NOT USE THE 110V ELECTRIC STARTER DURING RAINY WEATHER. DO NOT STAND IN WATER OR ON DAMP SURFACES WHEN CONNECTING CORD.

For the optional electric starter:

6. Plug the electrical cord into the electric start switch box on the engine.
7. Plug the other end of the electrical cord into a properly grounded 3-pronged 110V outlet.

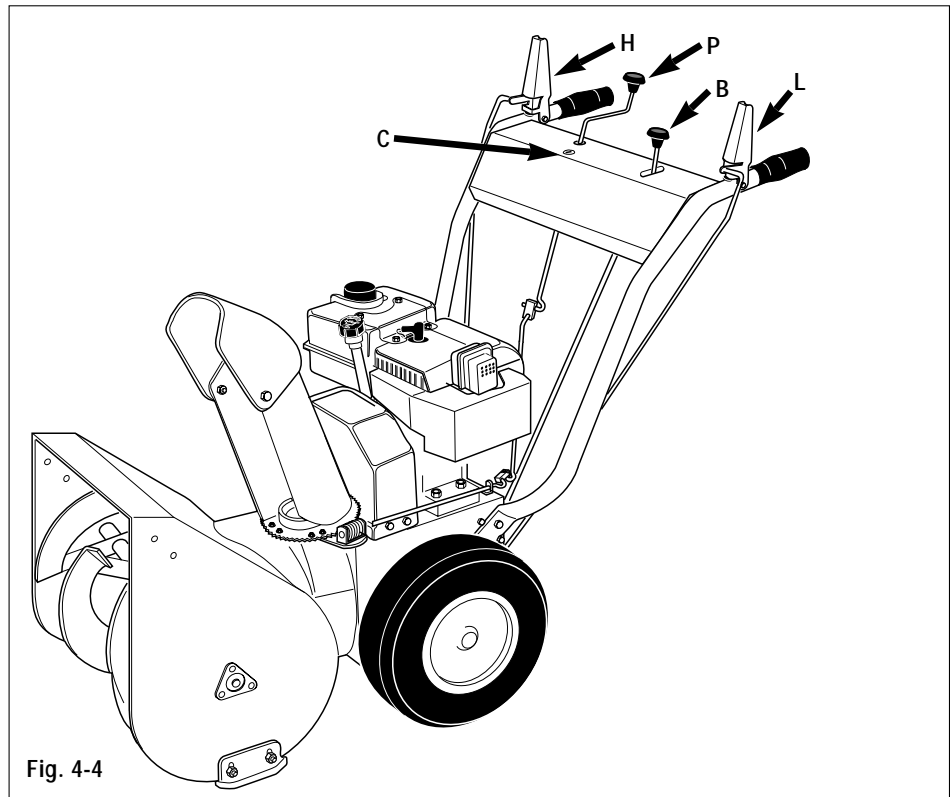

8. Push the starter button on the switch box. When the engine starts, release the button.

NOTE: The starter is thermally protected. When overheated from continuous use, the starter will stop functioning. Allow the starter to cool for several minutes before attempting to restart engine.

9. Move the choke knob "N" (D, Fig. 4-5) out of the full-choke position. Turn the choke off as the engine warms up.



Stopping

Emergency conditions:

1. Release both control levers (H and L, Fig. 4-4).
2. Rotate the ignition key (C, Fig. 4-4) to the "STOP" position.

Normal conditions:

1. Release both control levers (H and L, Fig. 4-4). Wait for the unit to come to a complete stop.

2. Move the throttle lever (F, Fig. 4-5) into the "  " position. Allow the engine to idle for several minutes to melt any snow on the engine.
3. Rotate the ignition key (C, Fig. 4-4) into the "STOP" position. Remove the key.
4. Disconnect the spark plug wire (J, Fig. 4-5) from the spark plug.
5. To prevent the unit from freezing-up:
 - a. Remove standing water from the floor of the auger housing.
 - b. Move the throttle lever (F, Fig. 4-5) into the "  " position.
 - c. Move the choke knob "N" (D, Fig. 4-5) into the full choke position.
 - d. Rotate the fuel shut-off valve (K, Fig. 4-5) to the "OFF" position.

Auger drive engagement

⚠ WARNING

STOP THE ENGINE AND REMOVE THE SPARK PLUG WIRE FROM THE SPARK PLUG BEFORE REMOVING ANY DEBRIS FROM THE AUGER HOUSING.

1. Remove any debris from inside the auger housing.
2. Adjust the discharge chute deflector cap (RR, Fig. 4-6) angle with adjustment lever (SS, Fig. 4-6). The discharge chute deflector cap should usually be adjusted to a low angle, so it is not pointing at any persons, animals, buildings or vehicle, especially in windy conditions.

NOTE: If the auger does not start or stop rotating as described in Steps 3 and 4 below, an adjustment is required. Refer to "Auger Drive Belt Adjustment" in the Maintenance section.

3. Engage the auger drive by squeezing the auger drive control lever (H, Fig. 4-4) down against the handlebar. The auger should immediately begin to rotate.
4. Disengage the auger drive by releasing the auger drive control lever (H). The auger should stop within five (5) seconds.

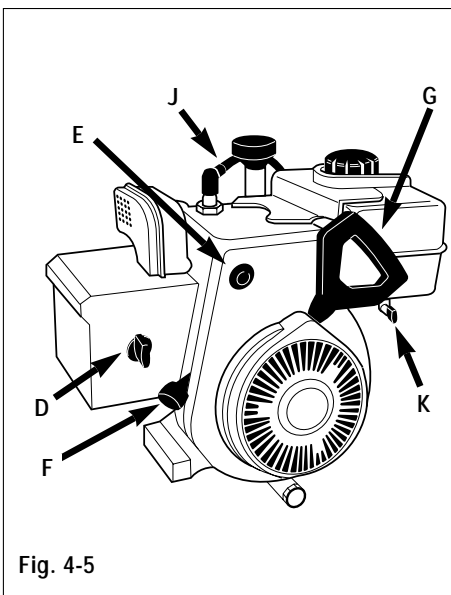

Fig. 4-5

Wheel drive engagement

1. Clear all obstructions from in front of the unit.
2. Stand behind the unit in the operating position.
3. Move the gearshift lever (B, Fig. 4-4) into the "1", or first gear, position.

NOTE: If the wheels do not start or stop rotating as described in Steps 4 and 5 below, an adjustment is required. Refer to "Wheel Drive Disc Adjustment" in the Maintenance section of this manual.

4. Engage the wheel drive by squeezing the wheel drive control lever (L, Fig. 4-4) against the handlebar. The unit should immediately move forward.
5. Disengage the wheel drive by releasing the wheel drive control lever. The wheels should stop.

NOTE: To move the unit without throwing snow, engage only the wheel drive lever.

Auger drive/Wheel drive interlock feature

The auger drive/wheel drive interlock feature allows the auger and the wheels to be operated with just one hand, thus freeing the other hand to operate the chute control crank rod. To engage both functions, squeeze both the auger and the wheel drive levers all the way down. Holding just the wheel drive lever will keep both levers down in the drive position. To disengage, release the wheel drive lever.

NOTE: If the auger drive control lever does not disengage when you release the wheel drive lever, an adjustment is required. Refer to "Auger Drive Belt Adjustment" in the Maintenance section.

Shifting gears

⚠ CAUTION

TRANSMISSION DAMAGE COULD OCCUR IF THE GEARSHIFT LEVER IS MOVED WHEN THE UNIT IS IN MOTION. CAREFULLY FOLLOW THE SHIFTING INSTRUCTIONS BELOW.

1. Release both the auger and wheel drive control levers (H and L, Fig. 4-4). Wait for the unit to come to a complete stop.
2. Move the gearshift lever (B, Fig. 4-4) into the desired position.
3. Re-engage the control levers (H and L).

NOTE: There should be full forward travel in gear position "5" and full reverse travel in gear position Reverse "2". If not, refer to "Gear Shift Rod Adjustment" in the Maintenance section.

Reverse

⚠ WARNING

USE EXTREME CAUTION WHEN OPERATING THE UNIT IN REVERSE. CLEAR ALL OBSTACLES AWAY FROM THE UNIT BEFORE OPERATING IN REVERSE. BE PREPARED FOR THE UNIT TO MOVE TOWARD YOU WHEN THE GEARSHIFT LEVER IS IN THE REVERSE POSITION.

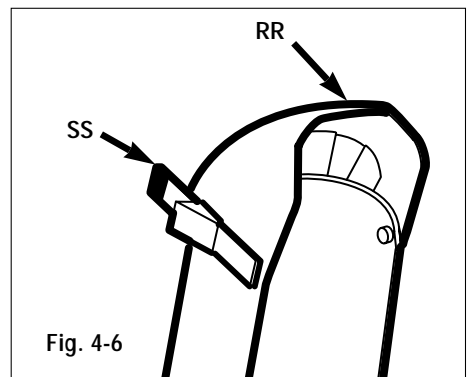

Fig. 4-6

Section 4: Operation

Transporting the unit

Release the auger drive control lever to disengage the auger drive whenever the unit is being transported to the work site.

The unit is extremely heavy. Have at least one other person help you when loading or unloading the unit into a truck or trailer. Use ramps when loading or unloading the unit onto a trailer or truck. Securely tie the unit to prevent shifting while in transit.

Snowthrowing tips

- Remove snow as soon as possible after a snowfall.
- Run the engine at full throttle (the " " position).
- Spray silicone spray onto the inside of: the auger housing, the discharge chute, the deflector cap, and also on the augers to help prevent snow from sticking. (Do not spray silicone on rubber or plastic: damage will result).
- Direct discharge downwind.
- If a smooth area is being cleared: adjust the skid shoes so the scraper blade is approximately 1/8" (3mm) from the ground.
- If a rough or gravel area is being cleared: adjust the skid shoes so the scraper blade clears the rough or gravel surface.
- Use low travel speeds for safety and to prevent overloading the unit.

WARNING

THOROUGHLY INSPECT THE AREA WHERE THE UNIT WILL BE USED BEFORE THE FIRST SNOWFALL. REMOVE ALL DOORMATS, SLEDS, BOARDS, WIRES AND OTHER DEBRIS TO PREVENT INJURY FROM THROWN OBJECTS.

⚠ DANGER

DO NOT USE YOUR HANDS OR FEET TO DISLodge SNOW FROM INSIDE THE AUGER HOUSING OR THE DISCHARGE CHUTE. ANY CONTACT WITH THE MOVING PARTS WILL CAUSE SERIOUS INJURY.

STOP THE ENGINE AND REMOVE THE SPARK PLUG WIRE FROM THE SPARK PLUG AND USE A LONG (AT LEAST 3' [100 CM] LONG) WOODEN STICK TO UNCLOG THESE AREAS.

Snowthrowing Patterns

Use pattern in Fig. 4-7 when snow can only be thrown to one side. Begin throwing snow closest to the side opposite where it can be thrown and direct the discharge away from that side. When turning the unit around after each pass, rotate the discharge chute as you proceed so snow continues to be thrown in the proper direction.

Use pattern in Fig. 4-8 to throw snow to both sides. When turning the unit, rotate the discharge chute as necessary to throw snow in the proper direction.

As you turn, rotate the discharge chute so that the snow is always thrown in this direction.

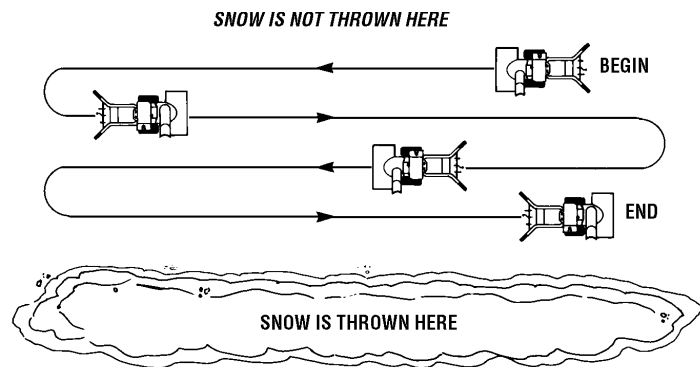

Fig. 4-7

The discharge chute stays the same direction except when turning. Snow is thrown to each side.

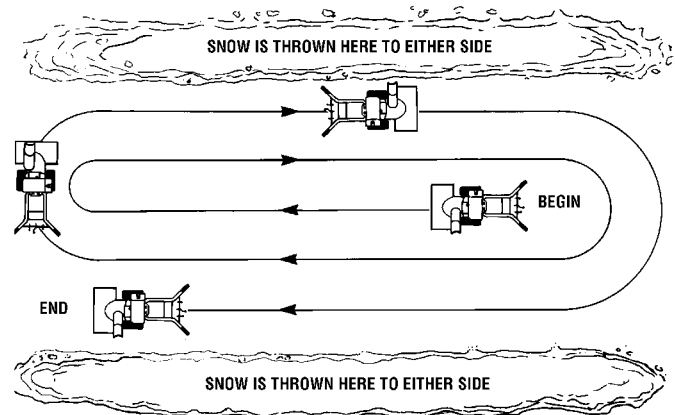

Fig. 4-8

Maintenance

Engine oil

Check the engine oil level each time before starting the unit and after each 5 hours of operation.

⚠ WARNING

BEFORE PERFORMING ANY MAINTENANCE OR ADJUSTMENTS TO THE UNIT SHUT OFF THE ENGINE AND ALLOW IT TO COOL. REMOVE THE IGNITION KEY. DISCONNECT THE SPARK PLUG WIRE FROM THE SPARK PLUG. PREVENT THE WIRE FROM CONTACTING THE PLUG.

To check the engine oil level:

1. Move the unit onto a level surface.
 2. Remove the oil dipstick (A, Fig. 5-1).
 3. Wipe the oil from the dipstick with a clean cloth.
 4. Screw the dipstick back into the engine.
 5. Remove the oil dipstick (A, Fig. 5-1) again.
 6. The oil level should be between the "FULL" and the "ADD" marks on the dipstick. Refer to the engine owner manual for proper oil specifications.
- To change the engine oil:
1. Start the engine and allow it to warm up to normal operating temperature.
 2. Stop the engine and wait for all moving parts to stop. Disconnect the spark plug wire from the spark plug.
 3. Move the unit onto a level surface.
 4. Remove the engine oil dipstick (A, Fig. 5-1) to allow venting for the engine crankcase.
 5. Place a container with a minimum capacity of two quarts below the oil drain opening.
 6. Fold a piece of cardboard or aluminum foil into a shallow "V", and position it so the oil will drain through it into the container.
 7. Remove the oil drain plug (B, Fig. 5-1) and allow the oil to drain into the container.
 8. When all oil has completely drained from the crankcase securely replace the oil drain plug (B).
 9. Refer to the engine owner manual for correct oil specifications. Fill the engine through the oil dipstick opening with the correct type and amount of oil as indicated in the engine owner manual.
 10. Securely replace the oil dipstick (A).

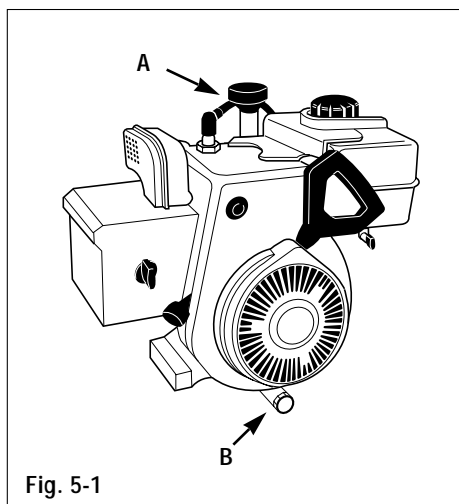

Fig. 5-1

NEVER DISPOSE OF WASTE OIL ON THE GROUND, DOWN A DRAIN OR INTO A LAKE, POND OR STREAM. CONTACT LOCAL ENVIRONMENTAL AUTHORITIES FOR PROPER OIL DISPOSAL INSTRUCTIONS.

Ignition system

The engine has an electronic ignition system which does not use points or a condenser. The spark plug is the only item requiring maintenance in this system.

Spark Plug

Annually or every 100 hours of operation, remove and inspect the spark plug. Replace the spark plug if the electrode is pitted or burned or if the porcelain is cracked. Refer to the engine owner manual for correct spark plug specifications (Fig. 5-2).

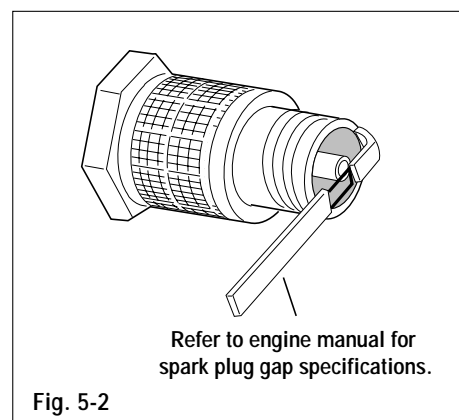

Fig. 5-2

Note: Use of an incorrect plug can damage the engine.

Carburetor

The carburetor has been adjusted at the factory and should not require additional adjustment. If a black exhaust is noticed, inspect the air cleaner first. An over-rich mixture is usually caused by a clogged air cleaner element, not an improperly adjusted carburetor. Refer to the engine owner manual or contact your dealer for additional carburetor information.

Section 5: Maintenance

Lubrication

At the beginning and end of each season or after every 25 hours of operation, lubricate the unit as recommended below:

1. Lightly oil both the deflector chute cap pivot points (D, Fig. 5-3).
2. Lightly oil the discharge chute control rod pivot points where the control rod enters the control panel bearing (E, Fig. 5-4), the support tab (F, Fig. 5-4), and the support on the left rear of unit housing (G, Fig. 5-6).
3. Remove the left wheel (H, Fig. 5-3). Clean the wheel shaft and apply multi-purpose grease to the wheel shaft. Reinstall the left rear wheel.
4. Apply oil to the bearings on sides of the auger shaft (J, Fig. 5-3).
5. Clean dirt and old grease from the flange at the bottom of the discharge chute (K, Fig. 5-3). Apply multi-purpose grease to the worm gear (C), toothed portion of flange and the flange.
6. Lightly lubricate the handlebar control levers at pivot points (M, Fig. 5-4) with oil or a non-silicone spray. Do not get oil or lubricating spray on levers.
7. Lightly oil the pivot points on the gear shift control lever (N, Fig. 5-4).
8. Remove the two shear bolts (C, Fig. 5-7) from the auger shaft, then lubricate the four auger grease fittings (O, Fig. 5-7) using a grease gun. Rotate auger three or four times. Reinstall shear bolts, torque to 11 ft-lbs (15Nm).
9. Check the auger gear case oil level :
 - a. Place the unit on a smooth, level surface. Unscrew the plug (P, Fig. 5-7) from the front of gear case.
 - b. Inspect plug hole. Oil should just begin to seep out of the hole. Add SAE 90 gear oil if necessary until oil just begins to flow out of hole. Let the excess oil drain out of the gear case.
 - c. Reinstall the plug (P).

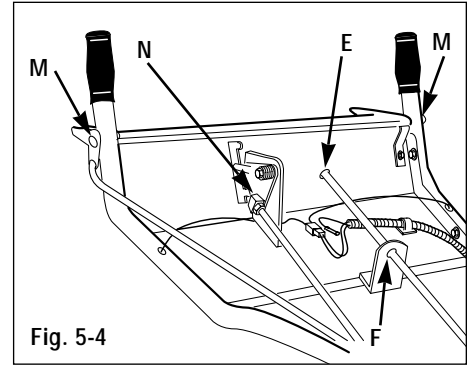

Fig. 5-4

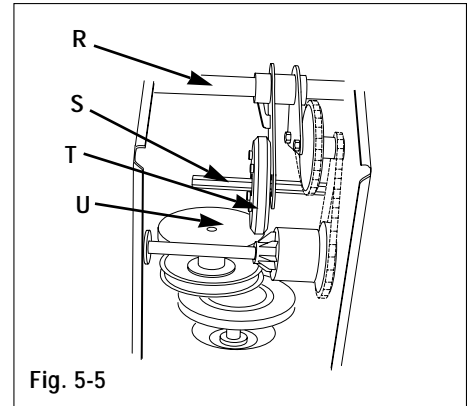

Fig. 5-5

10. Remove bolts (Q, Fig. 5-6) securing bottom cover to unit. Remove bottom cover. Put gear shift lever in highest speed setting and apply a coating of multi-purpose grease to the shafts (R and S, Fig. 5-5). Prevent grease from contacting rubber drive wheel (T) or drive disk (U). If grease should contact these parts, wipe clean to avoid slippage and assure proper operation. Move shift lever between high speed and reverse settings to spread grease along shafts. Replace bottom cover.

Wheel Drive Disc Adjustment

Due to wear, the wheel drive control disc may begin to slip when wheel drive lever is engaged. To adjust wheel drive disc:

1. Pull the wheel drive control arm (V, Fig. 5-6) down completely.
2. Measure and note the distance between the coiled ends of the spring (W, Fig. 5-6).
3. Squeeze wheel drive control lever (X, Fig. 5-3) against handlebar. Measure

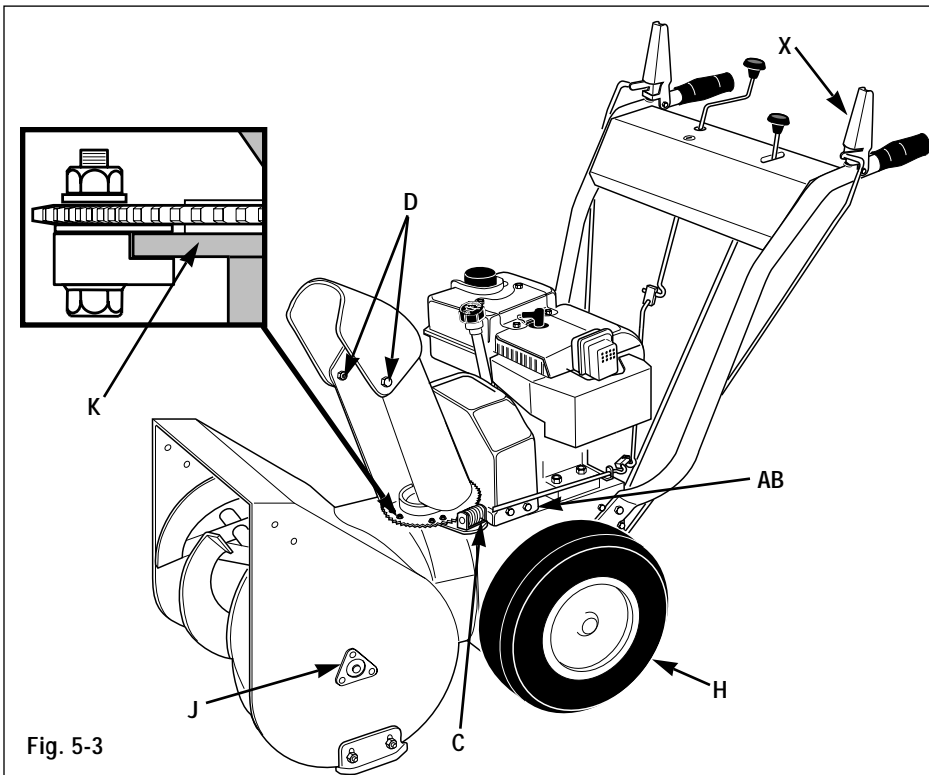

Fig. 5-3

length of spring (W, Fig. 5-6) again. The spring length should now measure 5/8" – 3/4" (15–19mm) longer than the measurement taken in step 2. If it does not, loosen jam nut (Y, Fig. 5-6) and turn adjuster (Z, Fig. 5-6) to increase or decrease the spring length. (1-1/4 turns of the adjuster equals 1/16" [1.5mm] of spring extension.) Hold the adjuster and tighten the jam nut (Y) when the correct spring length is obtained. Re-check measurements and adjust if needed.

If after completing this adjustment the wheels do not drive adequately, refer to "Drive Disc Clearance Adjustment" on page 25. Then repeat this adjustment.

Wheel Drive Belt Replacement

To remove the wheel drive belt:

1. Remove the bolts (AB, Fig. 5-3) and the belt cover from the unit.
2. Remove the two bolts securing belt guide (AC, Fig. 5-8) to the engine. Remove the belt guide.
3. Loosen jam nut (BA) and remove bolt (BB).
4. Release tension on the idler (AF). Remove the auger drive belt (AD, Fig. 5-8) from the auger drive pulley (AE).
5. Remove wheel drive belt (AG) from lower drive pulley (AH). Squeeze the wheel drive control lever against the handlebar (X, Fig. 5-3) to increase the gap between lower pulleys as needed.
6. Remove the belt from unit.

To install the wheel drive belt:

1. Position the belt into lower drive pulley closest to the engine.
2. Place the belt into the groove closest to the engine. Reinstall the auger drive belt in its pulley.
3. Position the belt guide (AC) back on the engine and secure with bolts removed earlier.
4. Reinstall bolt (BB), leaving 1/16" (1.5mm) clearance between underside of bolt head and front edge of pulley (AE). Tighten jam nut (BA) against engine crankcase.

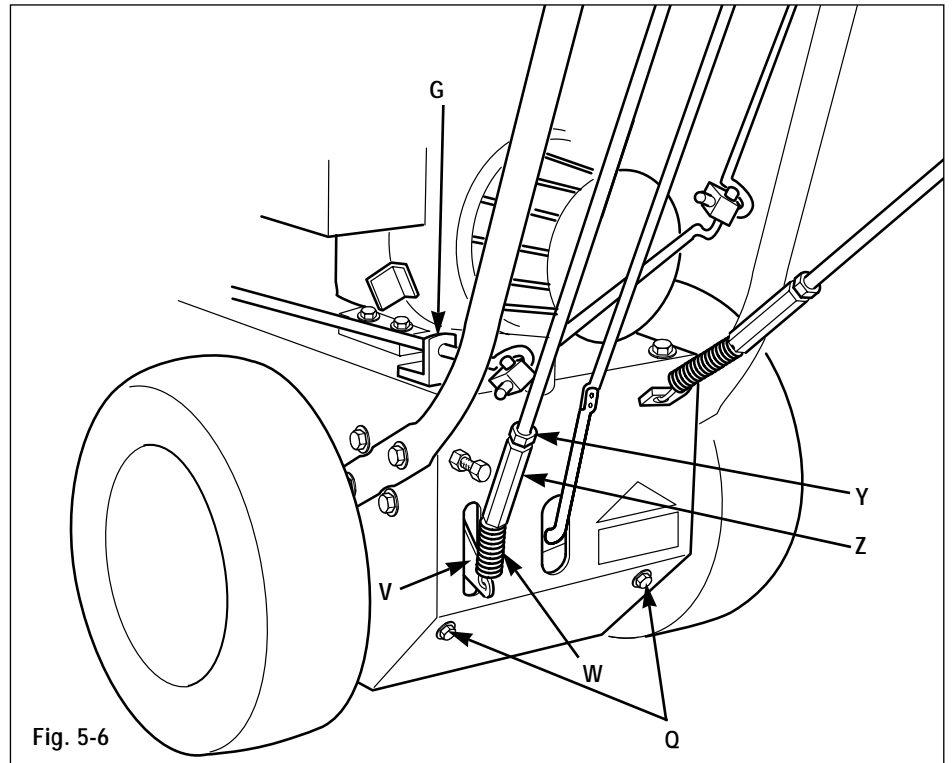

Fig. 5-6

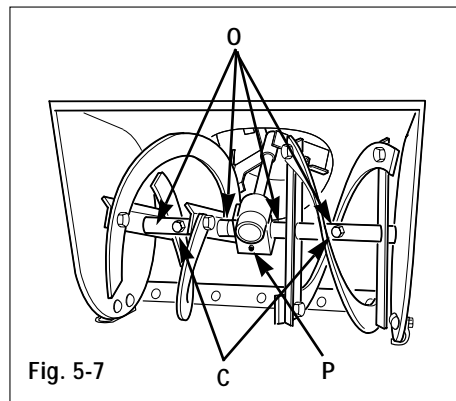

Fig. 5-7

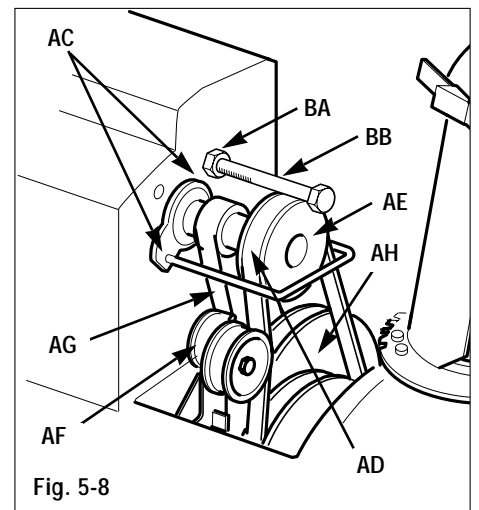

Fig. 5-8

5. Perform the wheel drive disc adjustment (above).
6. Reinstall the belt cover and bolts.

Shear Bolts

Special shear bolts (C, Fig. 5-7) secure the augers to auger shaft and are designed to break (shear) if the auger jams. This prevents damage to other, more vital parts. Inspect the shear bolts before each use and replace them if they are worn or broken.

Torque shear bolts to 11 ft-lbs (15 Nm).

CAUTION

USING ANYTHING BUT ORIGINAL EQUIPMENT SHEAR BOLTS COULD RESULT IN DAMAGE TO THE UNIT. USE AUGER SHAFT SHEAR BOLTS PART NUMBER 1735625, WHEN REPLACING SHEAR BOLTS.

Section 5: Maintenance

Auger Drive Belt Adjustment

Due to wear, the auger drive belt may begin to slip when the auger drive lever is engaged. To adjust the auger drive belt:

1. Perform the brake arm adjustment as described later in this section.
2. If assembling a new unit, raise the wheel drive control lever (AP, Fig. 5-9) and the auger drive control lever (AL).

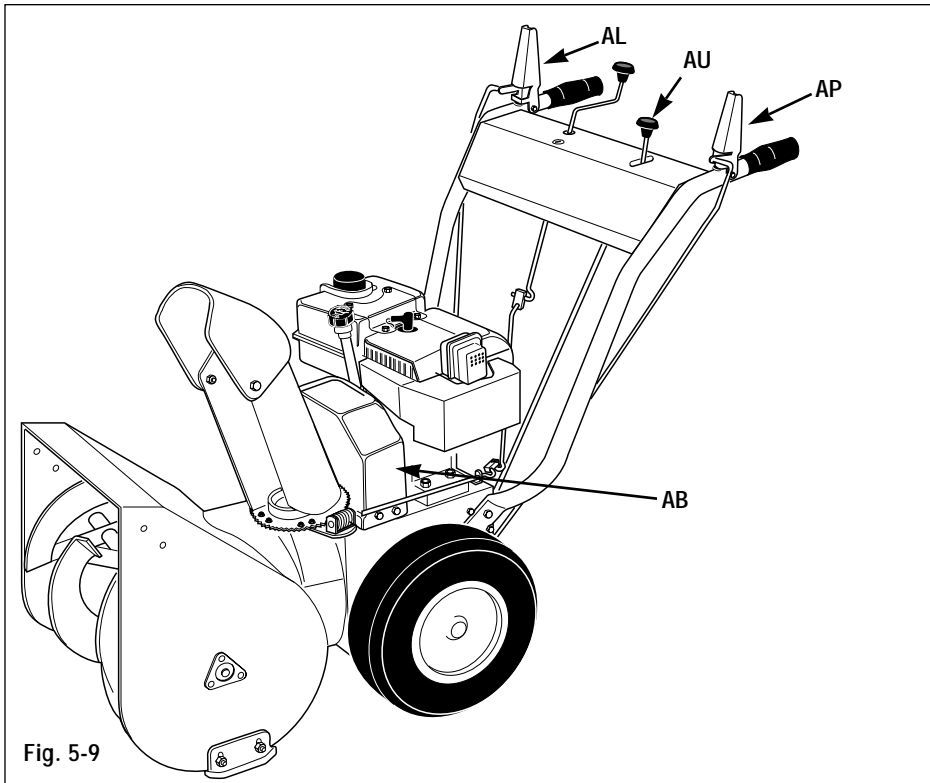

Fig. 5-9

3. Pull the auger drive control arm (AJ, Fig. 5-10) down completely.

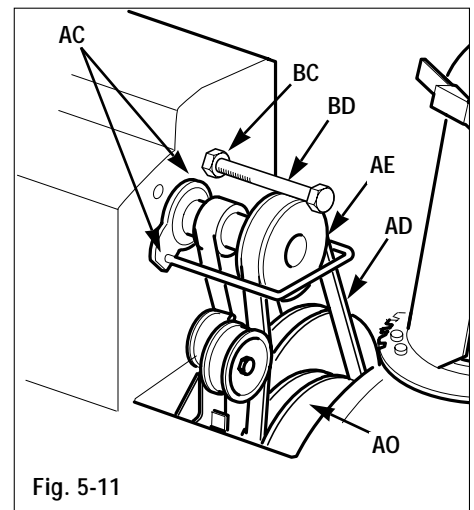

Fig. 5-11

4. Measure and note the length of the spring (AK, Fig. 5-10).
5. Squeeze the auger drive control lever (AL, Fig. 5-9) against the handlebar. Measure the length of the spring (AK, Fig. 5-10) again. The spring length should now measure $9/16'' - 11/16''$ (14–17mm) longer than the measurement taken in step 4. If it does not, loosen the jam nut (AM) and turn the adjuster (AN) to increase or decrease the length of the spring. Hold the adjuster and tighten the jam nut (AM) when the correct spring length is obtained. Re-check the measurements and adjust if needed.

NOTE: 1-1/4 turns of the adjuster equals 1/16" (1.5mm) of spring extension.

Auger Drive Belt Replacement

To remove the auger drive belt:

1. Remove the bolts, flat washers, and lockwashers securing the belt cover (AB, Fig. 5-9) to the unit. Remove the belt cover.
2. Remove the two bolts securing the belt guide (AC, Fig. 5-11) to the engine. Remove the belt guide.
3. Loosen jam nut (BC) and remove bolt (BD).
4. Remove the auger drive belt (AD) from the auger drive pulley (AE).

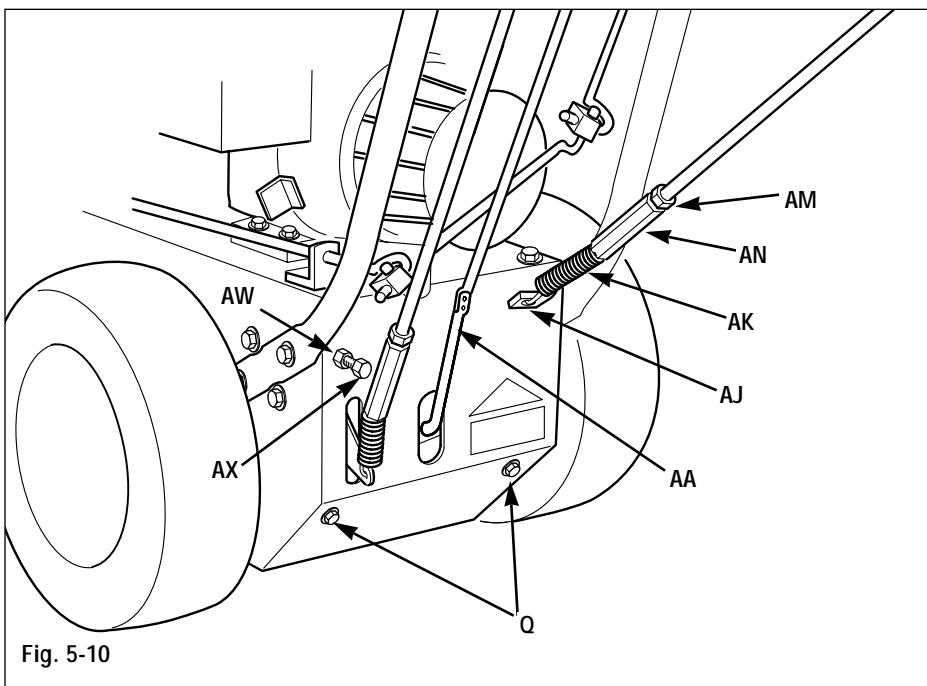

Fig. 5-10

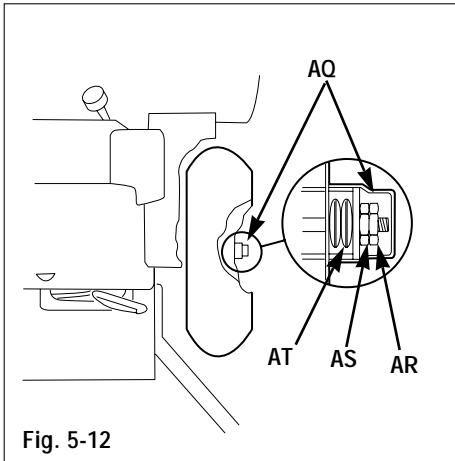

Fig. 5-12

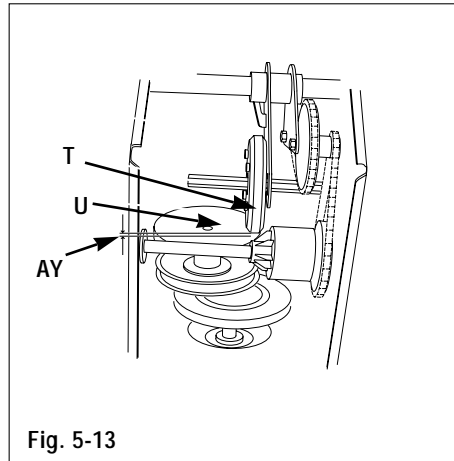

Fig. 5-13

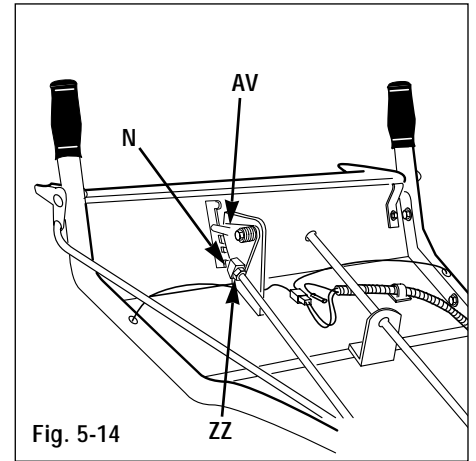

Fig. 5-14

5. Remove the auger drive belt from the lower drive pulley (AO).
6. Remove the belt from unit.

To install the auger drive belt:

1. Position the auger drive belt (AD) down through gap. Position the belt into the lower drive pulley (AO).
2. Position the auger drive belt (AD) into pulley (AE). Reinstall the belt guide (AC) and secure.
3. Reinstall bolt (BD), leaving 1/16" (1.5mm) clearance between underside of bolt head and front edge of pulley (AE). Tighten jam nut (BC) against engine crankcase.
4. Perform the auger drive belt adjustment as necessary.
5. Reinstall the belt cover and bolts.

Slip Differential Adjustment

1. On right side of unit, remove hub cap (AQ, Fig. 5-12) at end of wheel axle shaft. Remove outer (AR) and inner jam nuts (AS) and both pairs (four single disk springs) of disk springs (AT). Inspect springs and replace them if they are worn.
2. Reinstall disc springs (AT) and inner jam nut (AS). Tighten jam nut (AS) by hand until it contacts the disc spring, then tighten (AS) 1 to 1-1/4 turns more. DO NOT force nut more than 1-1/4 turns or differential will not work.

3. Secure the inner nut (AS) in place, while tightening the outer nut (AR).
4. Reinstall cover (AQ).

Gear Shift Rod Adjustment

1. Move the gear shift lever (AU, Fig. 5-9) to position No. 5. Remove the hairpin cotter and the flat washer from the pivot block (N, Fig. 5-14). Disconnect the pivot block (N) from the gear shift lever plate (AV, Fig. 5-14).
2. Pull the gear shift control rod (AA, Fig. 5-10) down completely.
3. While holding the gear shift control rod down (AA), loosen the jam nut (ZZ, Fig. 5-14) and thread the pivot block (N) up or down as needed so it fits into the hole in the gear shift lever plate (AV).
4. Reinstall the pivot block into the gear shift control lever hole and secure with the washer and hairpin cotter. Secure the jam nut (ZZ) against the pivot block (N).
5. Move the gear shift control lever (AU, Fig. 5-9) through the full range of travel. Check for binding. Refer to the drive disk clearance adjustment below, if needed.

Drive Disc Clearance Adjustment

If the gear shift rod lever does not move freely through all the gear positions, adjust clearance (AY, Fig. 5-13) as follows:

1. Loosen the jam nut (AW, Fig. 5-10). Rotate the adjusting screw (AX) until the rubber drive wheel (T, Fig. 5-13) contacts the metal drive disk (U).
2. Turn the rubber drive wheel (T) and the metal drive disk (U) to find the point of minimum clearance (AY). (This is where both the drive wheel [T] and metal disk [U] are touching.)
3. Adjust the disks at the point of minimum clearance. Loosen adjusting screw (AX) 1/2 turn. Secure the adjusting screw (AX) in place, while tightening the jam nut (AW).
4. Check the clearance (AY, Fig. 5-13) by moving gear shift lever (AU, Fig. 5-9) through all positions. Repeat step 3 as necessary.

Section 5: Maintenance

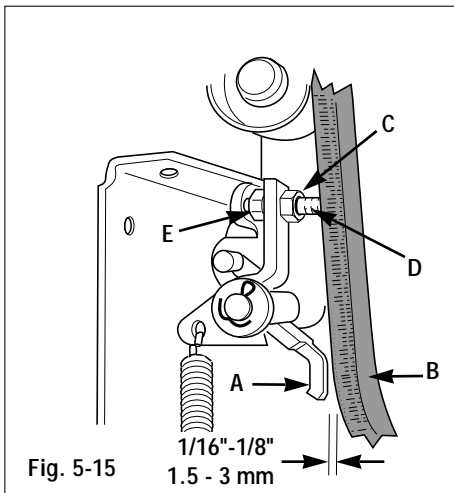

Fig. 5-15

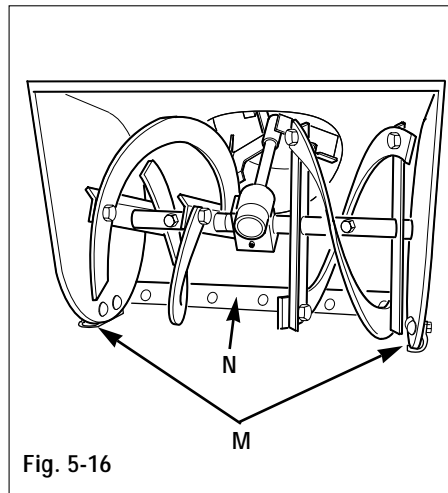

Fig. 5-16

Brake Arm Adjustment

The brake arm adjustment is set at the factory to 1/16 - 1/8" for proper belt/brake clearance. Due to wear this may need adjustment. To perform this adjustment:

1. Remove the bolts, flat washer, lock washer and belt cover (AB, Fig. 5-9).
2. Squeeze the auger drive control lever (AL, Fig. 5-9) against handlebar.
3. Using a flashlight, look down through the pulleys and belts (Fig. 5-11).

Check the gap between the brake arm (A, Fig. 5-15) and the belt (B). The gap should measure between 1/16" and 1/8" (1.5–3 mm).

4. To adjust the gap: Loosen nut (C). Hold the bolt (D) in place and rotate nut (E) until the proper clearance is obtained. Secure nut (C).
5. Reinstall the bolts and belt cover.

Skid shoes/Scraper blade

1. The unit should be adjusted so the auger housing and the scraper blade (N, Fig. 5-16) are 1/8" above the surface to be cleared. If the unit is used to clear gravel or uneven surfaces, this adjustment should be increased so gravel or other foreign objects are not scooped into the auger.

To adjust the auger housing/scraper blade height:

- a. Move the unit onto a level surface.
 - b. Loosen the hardware securing the skid shoes (M, Fig. 5-16).
 - c. Adjust the skid shoes (M) until they are in the correct position to support the auger housing and the scraper blade (adjust both skid shoes the same to prevent uneven snow removal).
 - d. Tighten the hardware to lock the skid shoes (M) into the proper position.
2. The scraper blade (N, Fig. 5-16) can also be adjusted. Adjust the scraper blade (N) at the carriage bolts. Adjust the bottom edge of the scraper blade so it is parallel with the bottom edge of the auger.

Off-season storage

When storing the unit for more than 90 days, follow these procedures to help keep the unit in good condition for future use:

- Clean dirt, grime and grease from the unit and engine.
- Perform routine lubrication as instructed earlier in this section.
- Add a fuel stabilizer to the fuel tank, according to the instructions provided with the stabilizer. Avoid leaving non-stabilized fuel in the fuel tank for longer than 30 days because gum and other deposits can form which could foul the carburetor and fuel line.
- If the unit is equipped with a fuel shut-off valve, rotate the valve to the "OFF" position.
- Change the engine oil.
- Remove the spark plug and squirt 1/2 ounce of engine oil into the spark plug hole. Hold a rag over the hole (be careful to prevent the rag from entering the hole). Slowly pull the recoil starter several times to coat the cylinder wall with oil. Re-install the spark plug, but leave the spark plug wire disconnected from the spark plug.
- Thoroughly inspect the unit for any loose, damaged, or missing parts. Repair or replace the parts as necessary.
- Check all nuts, bolts and other fasteners for tightness and tighten as necessary.
- Touch-up scratches and chipped paint to prevent corrosion.
- Store the unit on a level surface, out of the reach of children.

Section 5: Maintenance

Troubleshooting

TROUBLE	POSSIBLE PROBLEM	SOLUTION
Engine won't start	Ignition key in STOP position Choke knob in incorrect position Engine throttle lever in incorrect starting position Engine not primed enough (when cold) Engine primed too much (when cold) Spark plug wire disconnected Fouled or faulty spark plug Gasoline tank empty Fuel shutoff valve is closed Carb / fuel line "varnished" from old gas	Turn key to RUN "Ⓔ" position Move choke knob to FULL CHOKE position Move throttle lever to correct starting position Push primer button several more times Rotate choke knob to OFF position, move throttle lever to idle position, attempt to start engine, then proceed with normal starting procedure. DO NOT re-prime! Connect spark plug wire to spark plug Remove, clean, inspect, re-gap or replace spark plug Fill gasoline tank Open fuel shutoff valve Contact dealer
Engine difficult to start	Incorrect choke knob setting Engine throttle lever in incorrect position Fuel shutoff valve closed Engine not primed enough Stale gasoline in tank Fouled or faulty spark plug	Rotate choke knob to correct setting Rotate throttle lever to correct starting position Open fuel shutoff valve Push primer button several more times Drain gasoline from tank, refill tank with fresh gasoline Remove, clean, inspect, re-gap or replace spark plug
Engine idles rough	Faulty or fouled spark plug Incorrect choke setting	Remove, clean, inspect, re-gap or replace spark plug After the engine starts, gradually rotate the choke knob to the NO CHOKE position
Engine overheats	Dirty air screen Low engine oil level Dirty cooling fins Loose spark plug	Remove all debris from air screen Check oil, add as necessary Clean cooling fins Disconnect spark plug wire, re-tighten plug
Auger drive lever does not actuate auger	Tension too low on spring at lower end of auger drive control rod Broken auger shear bolts Loose or broken spring	Increase tension on spring Replace auger shear bolts Replace spring <i>(continued)</i>

Section 5: Maintenance

Troubleshooting (continued)

TROUBLE	POSSIBLE PROBLEM	SOLUTION
Auger drive control lever does not engage auger drive	Broken square key on engine drive pulley Broken woodruff key on input shaft	Replace key Replace key
Auger spins with drive lever disengaged	Tension too high on spring at lower end of auger drive control rod	Decrease spring tension
Wheel drive control lever does not turn wheels	Tension too low on spring at lower end of wheel drive control rod Broken wheel drive chain(s) Drive disk out of adjustment Broken or excessively worn wheel drive belt Broken square key on engine pulley	Increase spring tension Replace chain(s) Re-adjust drive disc Replace wheel drive belt Replace key
Wheels turn with wheel drive control lever disengaged	Tension too high on spring at lower end of wheel drive control rod Drive disk out of adjustment	Decrease spring tension Adjust drive disc
Snowthrower does not throw snow well	Discharge chute, impeller or auger clogged with snow, slush or ice Snow sticks to auger or chute Incorrect gear setting Loose auger drive belt	Stop engine, disconnect spark plug wire, use a long stick to unclog chute, auger and/or impeller Spray auger and chute with silicone lubricant When snowthrowing, generally use faster speeds – use slower speeds with heavier snow Adjust auger drive belt
Snowthrower does not clear snow	Skid shoes set too high Scraper blade adjusted incorrectly	Adjust skid shoes equally until scraper blade is evenly adjusted 1/8" (3 mm) above surface being cleared Adjust scraper blade until blade is evenly adjusted 1/8" (3 mm) above surface being cleared
Snowthrower makes sloping cut in snow	Skid shoes not set at equal height Scraper blade adjusted incorrectly	Adjust skid shoes to equal height Adjust scraper blade ends equally
Electric start motor won't crank engine	Electrical cord unplugged from outlet Blown fuse or thrown circuit breaker Faulty electrical cord or plug Overheated starter	Plug electrical cord into outlet Replace fuse or re-set circuit breaker Replace electrical cord Allow starter motor to cool before trying to start engine again

Section 5: Maintenance

Maintenance Chart

Interval	Item	Service
Before each use	Engine oil	Check level and condition
	All fasteners	Check for tightness
	Auger drive lever	Check operation
	Wheel drive lever	Check operation
After each use	Handlebar control levers and linkages	Lubricate
	Snowthrower	Remove all snow, slush and ice
Every 25 hours of operation or annually	Engine oil	Change
	Tires	Check pressure and condition
	Auger gear box	Check oil level
	Belts	Check for wear
	Cooling air screen	Check condition and clean
	Spark plug	Check, clean, re-gap or replace
Every 50 hours of operation or annually	Drive chains	Apply oil to drive chains, remove excess
Annually	Belts	Check for wear, damage and adjustment
	Brake	Adjust
	Auger	Grease (through grease fittings)
	Rusted areas	Sand, repaint

This table describes service guidelines only and does not provide complete service information. For complete service information, contact your local authorized dealer.

Optional Kits and Accessories

Kit	Description	Model/Part Number
Electric Starter Kit - 110V	Allows for electric starting of the unit using house current.	6857
Electric Starter Kit - 12V D.C.	Allows for electric starting of the unit using battery.	16008
Tire Chain Kit	Includes tire chains for added traction.	1756278
Drift Slicer Kit	Includes drift slicers and mounting hardware.	10771
Cab Kit	Includes three-sided protective cab, framework and hardware.	42500
Light Kit	Includes light, mounting hardware and wire lead.	16009
Blizzard Pack	Includes Light Kit, Cab Kit, and Electric Starter Kit - 110V.	42501
Service Kit	Includes two V-belts, spark plug, four shear bolts and top lock nuts, fuel stabilizer, 1 qt. motor oil and spray lubricant	1771731

The items listed above are available for your snowthrower. The information is the most current available at the time this literature was printed. To order the kits listed above, contact your dealer or call or write to the addresses listed on page 3 of this manual.

Specifications

Specifications

Below is a list of specifications for your snowthrower. The information is the most current at the time this manual was printed.

Snowthrower Models 42010, 42012, 42030, & 42031	
<p>Snowthrower Height.....To top of handlebar levers: 41.5" (105.3 cm) w/o handlebars, deflector cap down: 33" (83.75 cm) Length.....With handlebars: 70" (177.6 cm) Without handlebars: 41.0" (104 cm) Weight (approximate) 42010, 42030295 lbs. (134 Kg) 42012, 42031315 lbs. (143 Kg)</p> <p>Tires Type.....2-ply Size4.80/4.00 x 8 Air Pressure.....8 to 12 psi (55-82 kPa)</p> <p>Clearing Width42010,42030: 24" (61 cm) 42012, 42031: 26" (65.6 cm)</p> <p>Engine 42010, 420308 H.P. (5.97 kW) Tecumseh HMSK80 42012, 4203110 H.P. (7.46 kW) Tecumseh HMSK100 Type....."Snow King", winterized, 4-cycle, air-cooled Displacement 42010, 4203042.18 cid (0.691 L) 42012, 4203149.98 cid (0.769 L) Bore x Stroke 42010, 420303.125 x 2.5312 in. (79.9 x 64.31 mm) 42012, 420313.3125 x 2.5312 in. (84.14 x 64.31 mm)</p>	<p>CarburetorFloat type, primer and choke- winterized GovernorMechanical High Speed3450 RPM Idle Speed1700 RPM Speed Setting.....3450 RPM Lubrication.....Splash system Oil FillExtended oil fill and dipstick on top of cylinder Oil Drain.....Rear</p> <p>Engine Oil TypeRefer to engine owner's manual for manufacturer's recommendations Capacity.....26 U.S. ozs. (0.77 L)</p> <p>IgnitionElectronic</p> <p>Spark Plug Type/Gap.....Refer to engine owner's manual</p> <p>Fuel TypeUnleaded Regular Tank1 U.S. gallon (3.79 L), fuel shut-off valve FilterFine mesh, molded into tank</p> <p>Gear Case Type.....Impeller shaft with worm gear Gear OilSAE 90-weight gear oil</p> <p>Wheel Drive7 speeds (5 Forward, 2 Reverse)</p>

Wiring Diagram

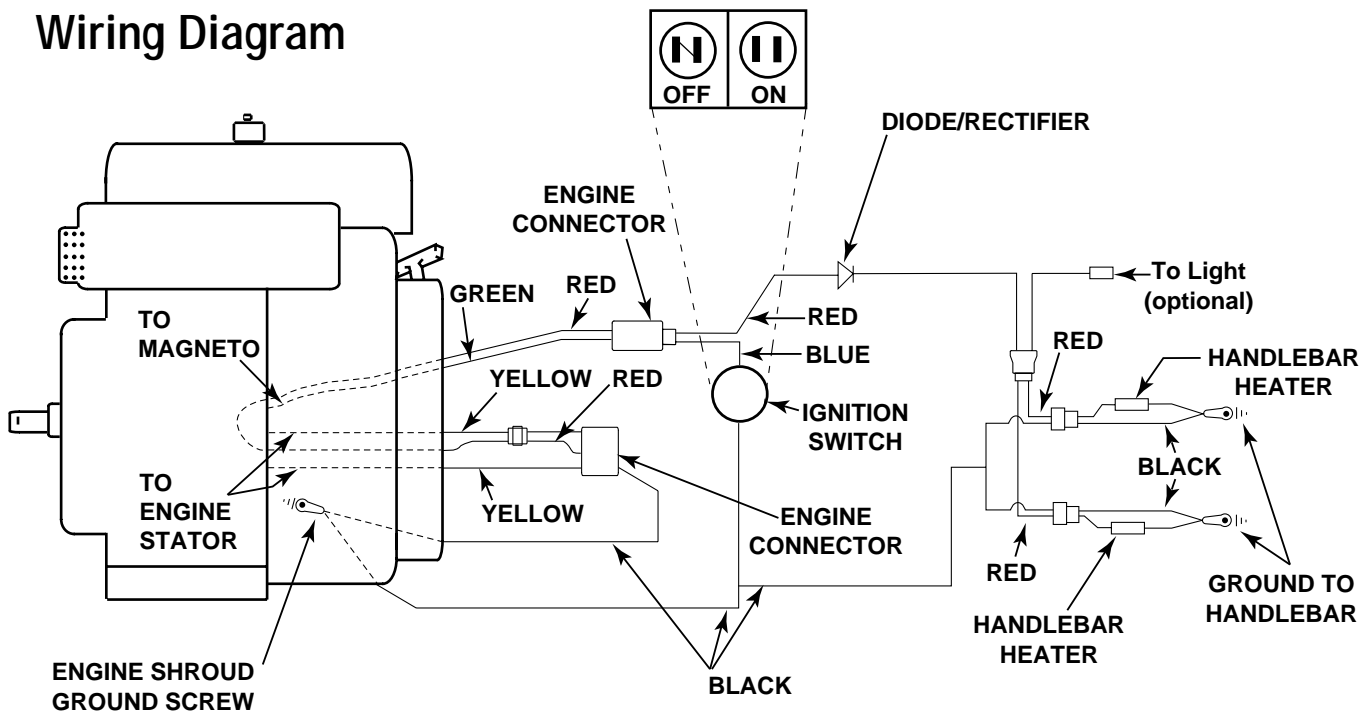

For customer assistance, contact your nearest authorized dealer or:

GARDEN WAY INCORPORATED • 1 Garden Way • Troy, New York U.S.A. 12180

Customer Service: 1-800-437-8686 • Technical Service: 1-800-520-5520 • Parts Service: 1-800-648-6776 • FAX: (518) 391-7332

Outside the U.S.A. and Canada:

Customer Service: (518) 391-7007 • For Technical Service: (518) 391-7008 • Parts Service: (518) 391-7006 or FAX: (518) 391-7332