

SUBMITTAL SHEET



AIRCONDITIONING PRODUCTS

SYSTEM INDOOR/OUTDOOR

42XS32A XS4232/C4232A

CEILING RECESSED (4 WAY) AIR CONDITIONER

SS42XS32A-2

GENERAL DATA (AT 230V)

POWER V/PH/HZ	230/208/1/60
Circuit Ampacity, Min. (A)	30
Fuse size, Max. (A)	50

COMPRESSOR	Scroll-Hermetic
No. used	1
R.L. Amps - L.R. Amps (A)	18.1 -131
Crankcase Heater	-

OUTDOOR FAN - TYPE	Propeller
Dia. (in.) - No. used	18-3/32 - 2
Type Drive - No. speeds	Direct - 2 (AUTO)
No. Poles - RPM (High)	6 - 879
No. Motors - Watts	2 - 110
CFM (High)	3,450
F.L. Amps. (A)	1.8

OUTDOOR COIL - TYPE	Aluminum Fin & Copper Pipe
Fin Type - Pipe Type	Slit Plate - Inner Riffled
Rows - F.P.I.	2 - 12.7
Face Area (sq.ft.)	11.63
Tube Size (in.)	3/8

INDOOR FAN - TYPE	Turbo
Dia. & Length (in.) - No. used	19-9/32 -1
No. speeds	3 & Auto
No. Poles -RPM (High)	6 - 560
No. Motors - Watts	1- 60
CFM (HI/MED/LOW)	980/830/650
F.L. Amps (A)	0.9

INDOOR COIL - TYPE	Aluminum Fin & Copper Pipe
Fin Type - Pipe type	Slit Plate - riffled
Rows - F.P.I.	2 - 14.9
Face Area (sq. ft.)	5.17
Tube Size (in.)	5/16
Drain Connection Size (in.)	3/4

REFRIGERANT	R22
Lbs. - R22 (O.D. Unit)	9.7
Control	Capillary Tube
Connection	Flare
Line Length, Max (ft.)	165
Lift difference, Max (ft.)	100
Line Size - in. O.D. Discharge	3/8
Line Size - in. O.D. Suction	3/4

DIMENSIONS (in.)	H	x	W	x	D
Indoor Unit -Uncrated	14-3/32	x	45-9/32	x	33-27/32
-Crated	12-7/16	x	43- 27/32	x	32-25/32(Indoor unit)
	4-3/32	x	49-1/2	x	39-11/32(Indoor Grille)
Outdoor unit -Uncrated	48-5/8	x	37	x	13-3/8
-Crated	52 -7/32	x	40	x	16-3/8

WEIGHT	INDOOR	OUTDOOR
Net (lbs.)	75	198
Shipping (lbs.)	71/29(Grille)	223

Shipping Volume (cu.ft.)	10.4/4.6(Grille)	19.8
--------------------------	------------------	------

PERFORMANCE DATA @ ARI STANDARD CONDITIONS (230/208V)

COOLING	
Total Capacity (BTU/H)	42,000/40,500
Sensible Capacity(BTU/H)	22,360/21,470
Latent Capacity (BTU/H)	19,640/19,030
SEER	10.2/10.3
Dehumidification (Pints/H)	14.6/14.8
Amps (A)	20.8/21.1
Power Inputs (W)	4,230/4,120
Outdoor Sound Rating (bels)	7.9

FEATURE

Controls	Microprocessor
Remote Controller	LCD Wireless type
Temperature Control	IC Thermostat
Timer	ON/OFF, 24 hours
Night Setback	Built-In
Air Louver (Horizontal)	-
(Vertical)	Automatic
Power Failure Automatic Restart	Built-In
Self Diagnosis	N/A

OPTION

Refrigerant Line Set	AP3210BH (30 ft)	AP3215BH (50 ft)
Low Ambient Control	N/A	
Fresh Air Intake	CMB-GS140T-	
Air duct Extension	Available	
Condensate Drain Pump	Built-In	
Non-Removable Remo-con Bracket	RCS5PS4B	
Wired Remote Control	RCS-102WD/RCS-302WD	

OPERATING RANGE

Cooling	Indoor Air Intake Temp:	Outdoor Air Intake Temp:
Maximum	95 F DB/71 F WB	115 F DB
Minimum	67 F DB/57 F WB	67 F DB

CERTIFICATION



42XS32A

SUBMITTAL SHEET



AIRCONDITIONING PRODUCTS

SYSTEM INDOOR/OUTDOOR
42XLS32A XS4232/CL4232A
 CEILING RECESSED (4-WAY) LOW AMBIENT AIR CONDITIONER

SS42XLS32A-2

GENERAL DATA (AT 230V)

POWER V/PH/Hz	230/208/1/60
Circuit Ampacity, Min. (A)	30
Fuse size, Max. (A)	50

COMPRESSOR	Scroll-Hermetic
No. used	1
R.L. Amps - L.R. Amps (A)	18.1 -131
Crankcase Heater	30W

OUTDOOR FAN - TYPE	Propeller
Dia. (in.) - No. used	8-3/32 - 2
Type Drive - No. speeds	Direct - 3 (AUTO)
No. Poles - RPM (High)	6 - 879
No. Motors - Watts	2 - 110
CFM (High)	3,450
F.L. Amps. (A)	1.8

OUTDOOR COIL - TYPE	Aluminum Fin & Copper Pipe
Fin Type - Pipe Type	Slit Plate - Inner Riffled
Rows - F.P.I.	2 - 12.7
Face Area (sq.ft.)	11.63
Tube Size (in.)	3/8

INDOOR FAN - TYPE	Turbo
Dia. & Length (in.) - No. used	19-9/32 -1
No. speeds	3 & Auto
No. Poles -RPM (High)	6 - 560
No. Motors - Watts	1 - 60
CFM (HI/MED/LOW)	980/830/650
F.L. Amps (A)	0.9

INDOOR COIL - TYPE	Aluminum Fin & Copper Pipe
Fin Type - Pipe type	Slit Plate - riffled
Rows - F.P.I.	2 - 14.9
Face Area (sq. ft.)	5.17
Tube Size (in.)	5/16
Drain Connection Size (in.)	3/4

REFRIGERANT	R22
Lbs. - R22 (O.D. Unit)	9.7
Control	Capillary Tube
Connection	Flare
Line Length, Max (ft.)	165
Lift difference, Max (ft.)	100
Line Size - in. O.D. Discharge	3/8
Line Size - in. O.D. Suction	3/4

DIMENSIONS (in.)	H	x	W	x	D
Indoor Unit -Uncrated	14-3/32	x	45-9/32	x	33-27/32
-Crated	12-7/16	x	43- 27/32	x	32-25/32(Indoor unit)
	4-3/32	x	49-1/2	x	39-11/32(Indoor Grille)
Outdoor unit -Uncrated	48-5/8	x	37	x	13-3/8
-Crated	52 -7/32	x	40	x	16-3/8

WEIGHT	INDOOR	OUTDOOR
Net (lbs.)	75	198
Shipping (lbs.)	71/29 (Grille)	223
Shipping Volume (cu.ft.)	10.4/4.6(Grille)	19.8

PERFORMANCE DATA @ ARI STANDARD CONDITIONS (230/208V)

COOLING		
Total Capacity (BTU/H)		42,000/40,500
Sensible Capacity (BTU/H)		22,360/21,470
Latent Capacity (BTU/H)		19,640/19,030
SEER		10.2/10.3
Dehumidification (Pints/H)		14.6/14.8
Amps (A)		20.8/21.1
Power Inputs (W)		4,230/4,120
Outdoor Sound Rating (bels)		7.9

FEATURE

Controls	Microprocessor
Remote Controller	LCD Wireless type
Temperature Control	IC Thermostat
Timer	ON/OFF, 24 hours
Night Setback	Built-In
Air Louver (Horizontal)	-
(Vertical)	Automatic
Power Failure Automatic Restart	Built-In
Self Diagnosis	N/A

OPTION

Refrigerant Line Set	AP3210BH (30 ft) AP3215BH (50 ft)
Low Ambient Control	N/A
Fresh Air Intake	CMB-GS140T-
Air duct Extension	Available
Condensate Drain Pump	Built-In
Non-Removable Remo-con Bracket	RCS5PS4B
Wired Remote Control	RCS-102WD/RCS-302WD

OPERATING RANGE

Cooling	Indoor Air	Outdoor Air
	<u>Intake Temp.</u>	<u>Intake Temp.</u>
Maximum	95 F DB/71 F WB	115 F DB
Minimum	67 F DB/57 F WB	0 F DB

CERTIFICATION



42XLS32A

Dimensional Data

Indoor Unit: XS4232

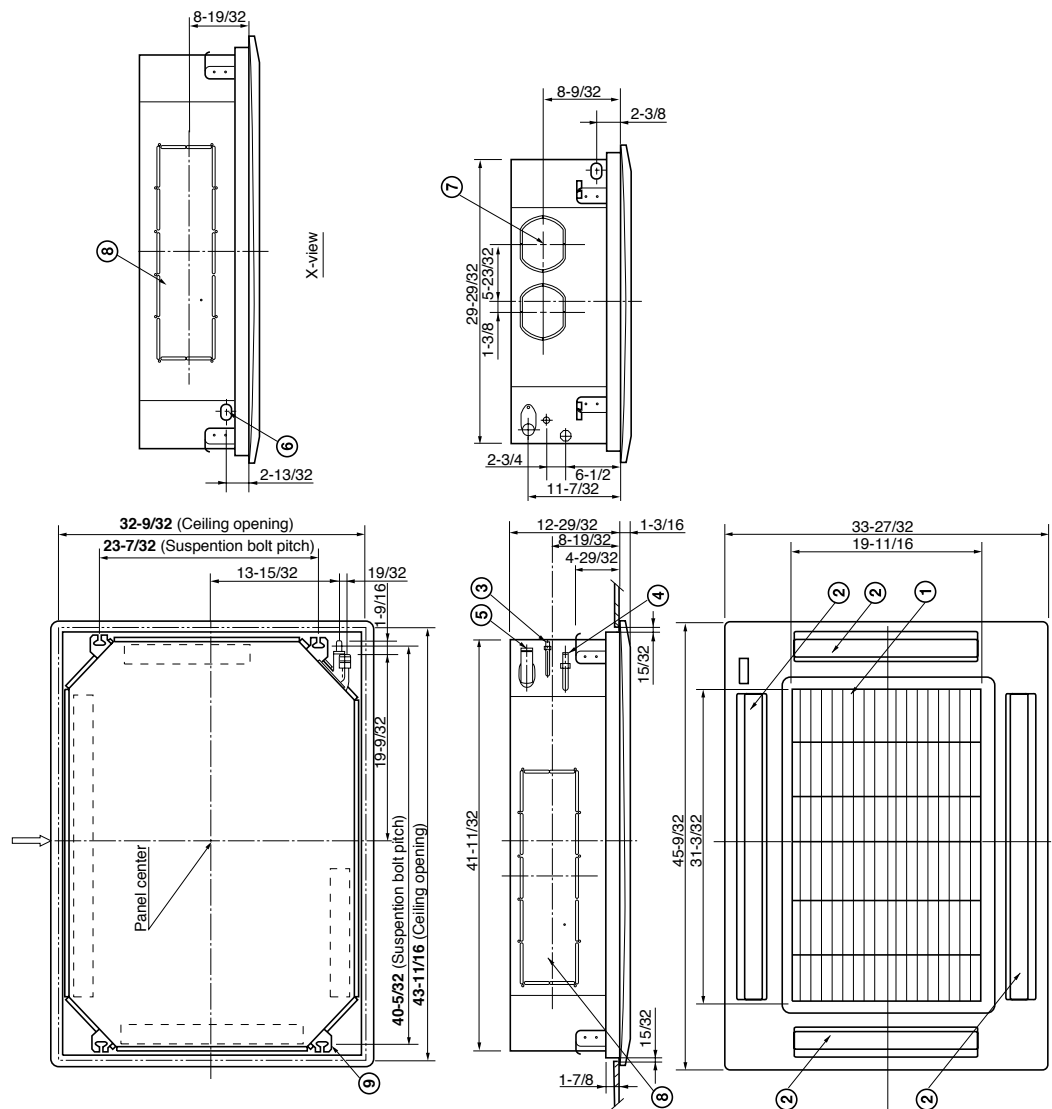

Outdoor Unit: C4232/CL4232

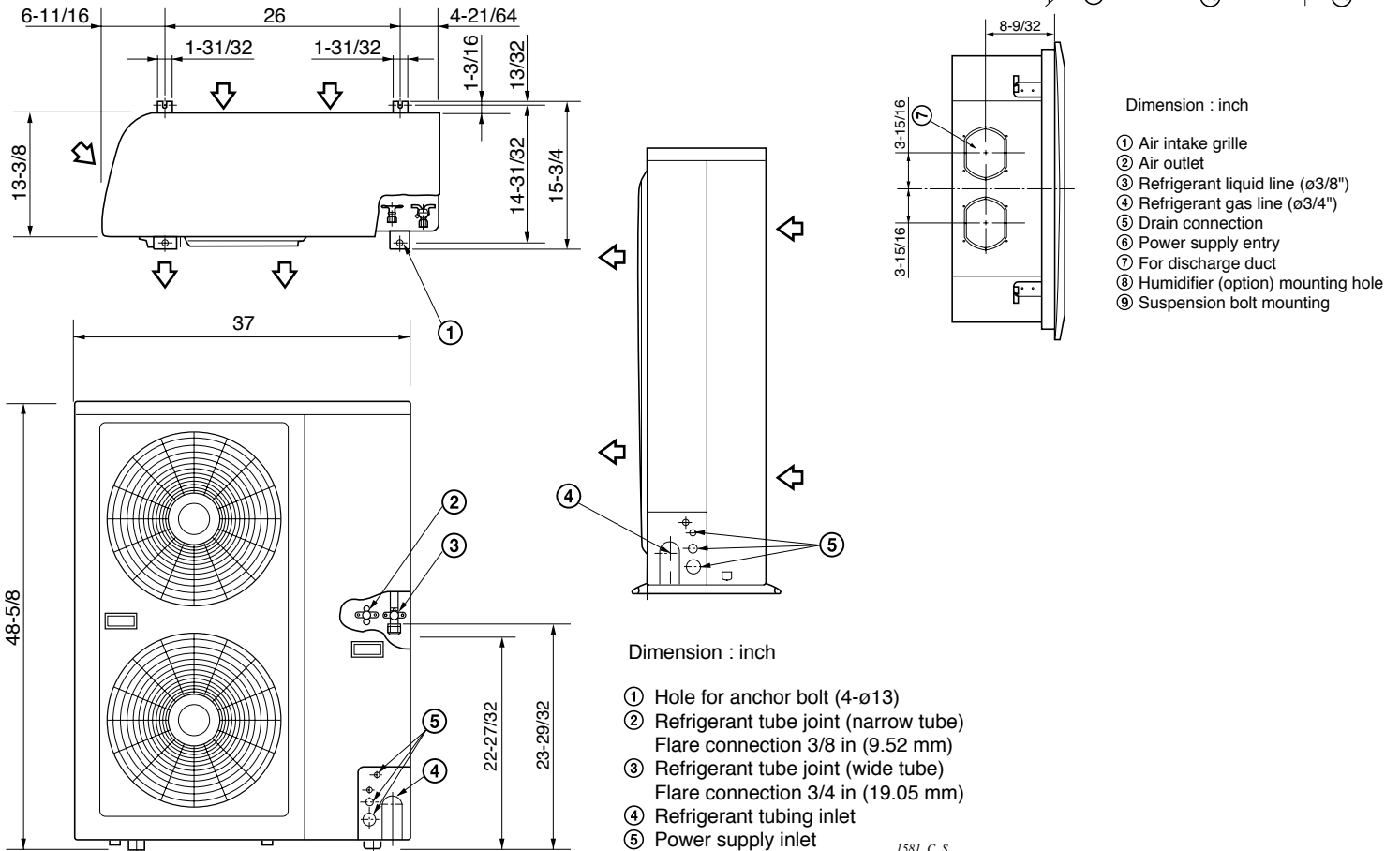

WARRANTY

SANYO products are warranted against defects in materials and workmanship for the period below;

	LABOR	PARTS
Compressor	30 Days	5 Years
Other Components	N/A	1 Year

Full specific warranty rights, conditions, exclusions and obligations are specified in the warranty packed with each products.

Because of a policy of continuous product improvements, SANYO reserves the right to change specifications and design without notice.

SANYO FISHER COMPANY
A Division of SANYO North America Corporation
21605 Plummer St. Chatsworth, CA 91311
Phone : (818) 998-7322
Fax : (818) 701-4160
Website: <http://www.sanyohvac.com>