

Tonka®

AGES 2+
90146/90145 Asst.

"We've got
work to do!"

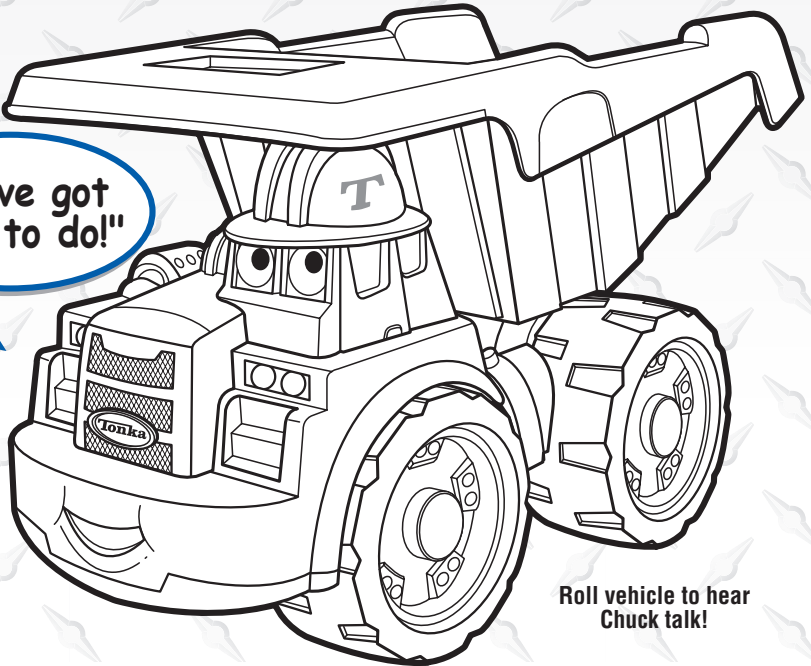

Roll vehicle to hear
Chuck talk!

CHUCK MY TALKING DUMP TRUCK™

Batteries included. Replace with 2 x 1.5V "AA" or R6 size batteries. Alkaline batteries recommended. Phillips/cross head screwdriver (not included) needed to replace batteries.



CHUCK & FRIENDS are talking trucks with the buddy built right in! They always have something to say and kids will love to make them talk! **CHUCK MY TALKING DUMP TRUCK** and all his friends are revved up and ready for adventure!

TO REPLACE BATTERIES

Using a Phillips/crosshead screwdriver (not included), loosen screw in battery compartment cover. Remove cover. Remove and discard batteries. Insert 2 x 1.5V "AA" or R6 size batteries. Alkaline batteries recommended. Replace door and tighten screw with screwdriver. See diagrams for polarity.

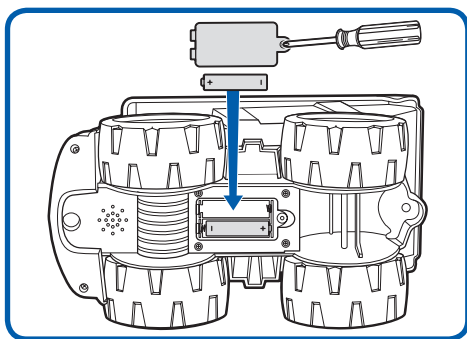

CAUTION: TO AVOID BATTERY LEAKAGE

1. Be sure to insert the batteries correctly and always follow the toy and battery manufacturers' instructions;
2. Do not mix old and new batteries or alkaline, standard (carbon-zinc) or rechargeable (nickel-cadmium) batteries;
3. Always remove weak or dead batteries from the product.

IMPORTANT: BATTERY INFORMATION

Please retain this information for future reference.
Batteries should be replaced by an adult.



CAUTION:

1. Always follow the instructions carefully. Use only batteries specified and be sure to insert them correctly by matching the + and - polarity markings.
2. Do not mix old batteries and new batteries, or standard (carbon-zinc) with alkaline batteries.
3. Remove exhausted or dead batteries from the product.
4. Remove batteries if product is not to be played with for a long time.
5. Do not short-circuit the supply terminals.
6. Should this product cause, or be affected by, local electrical interference, move it away from other electrical equipment. Reset (switching off and back on again or removing and re-inserting batteries) if necessary.
7. RECHARGEABLE BATTERIES: Do not mix these with any other types of battery. Always remove from the product before recharging. Recharge batteries under adult supervision. DO NOT RECHARGE OTHER TYPES OF BATTERIES.

FCC Statement:

This equipment has been tested and found to comply with the limits for a Class B digital device, pursuant to part 15 of the FCC Rules. These limits are designed to provide reasonable protection against harmful interference in a residential installation. This equipment generates, uses and can radiate radio frequency energy, and, if not installed and used in accordance with the instructions, may cause harmful interference to radio communications. However, there is no guarantee that interference will not occur in a particular installation. If this equipment does cause harmful interference to radio or television reception, which can be determined by turning the equipment off and on, the user is encouraged to try to correct the interference by one or more of the following measures:

- Reorient or relocate the receiving antenna.
- Increase the separation between the equipment and receiver.
- Consult the dealer or an experienced radio/TV technician for help.

Visit



Tonka.com



Product and colors may vary.
© 2006 Hasbro. All Rights Reserved.
TM & © denote U.S. Trademarks.

P/N 655710000