

6 Quart Slow Cooker

USE AND CARE GUIDE
MODEL TSC6W



IMPORTANT SAFEGUARDS

When using electrical appliances, basic safety precautions should always be followed, including the following:

- ◆ Read all instructions.
- ◆ Do not touch hot surfaces. Use handles or knobs.
- ◆ To protect against electrical shock, do not immerse cord, plugs or appliance in water or other liquid.
- ◆ Close supervision is necessary when any appliance is used by or near children.
- ◆ Unplug from outlet when not in use and before cleaning. Allow to cool before putting on or taking off parts.
- ◆ Do not operate any appliance with a damaged cord or plug or after the appliance malfunctions, or has been damaged in any manner. Contact Consumer Service for examination, repair or adjustment.
- ◆ The use of accessory attachments not recommended by the appliance manufacturer may cause injuries.
- ◆ Do not use outdoors.
- ◆ Do not let cord hang over edge of table or counter, or touch hot surfaces.
- ◆ Do not place on or near a hot gas or electric burner, or in a heated oven.
- ◆ Extreme caution must be used when moving an appliance containing hot oil or other hot liquids.
- ◆ To disconnect, turn Control Knob to “off”, then remove plug from wall outlet.
- ◆ Do not use appliance for other than intended use.
- ◆ Avoid sudden temperature changes, such as adding refrigerated foods into a heated pot.

SAVE THESE INSTRUCTIONS

For Household Use Only



ADDITIONAL IMPORTANT SAFEGUARDS

CAUTION HOT SURFACES: This appliance generates heat and escaping steam during use. Proper precautions must be taken to prevent the risk of burns, fires, or other injury to persons or damage to property.

- ◆ A person who has not read and understood all operating and safety instructions is not qualified to operate this appliance. All users of this appliance must read and understand this Use and Care Guide before operating or cleaning this appliance.
- ◆ If the Cooking Base falls or accidentally becomes immersed in water, unplug it from the wall outlet immediately. **Do not reach into the water!**
- ◆ When using this appliance, provide adequate air space above and on all sides for air circulation. Do not operate this appliance while it is touching or near curtains, wall coverings, clothing, dishtowels or other flammable materials.
- ◆ Do not leave this appliance unattended during use.
- ◆ If this appliance begins to malfunction during use, immediately unplug the cord. Do not use or attempt to repair a malfunctioning appliance!
- ◆ The cord to this appliance should only be plugged into a 120V AC electrical wall outlet.
- ◆ Do not use this appliance in an unstable position.
- ◆ Never use the Stoneware Liner on a gas or electric cooktop or on an open flame.
- ◆ Lift off Glass Lid carefully to avoid scalding, and allow water to drip into Stoneware Liner.
- ◆ **CAUTION: To prevent damage or shock hazard, do not cook in Cooking Base. Cook only in Stoneware Liner provided.**

Polarized Plug

This appliance has a polarized plug, (one blade is wider than the other). To reduce the risk of electric shock, this plug is intended to fit into a polarized outlet only one way. If the plug does not fit fully in the outlet, reverse the plug. If it still does not fit, contact a qualified electrician. Do not attempt to modify the plug in any way.

Short Cord Instructions

A short power-supply cord is provided to reduce the risk resulting from becoming entangled in or tripping over a longer cord.

Do not use an extension cord with this product.

Electric Power

If the electrical circuit is overloaded with other appliances, your appliance may not operate properly. It should be operated on a separate electrical circuit from other appliances.



Getting to know your **Toastmaster** Slow Cooker

Your product may vary slightly from illustration.

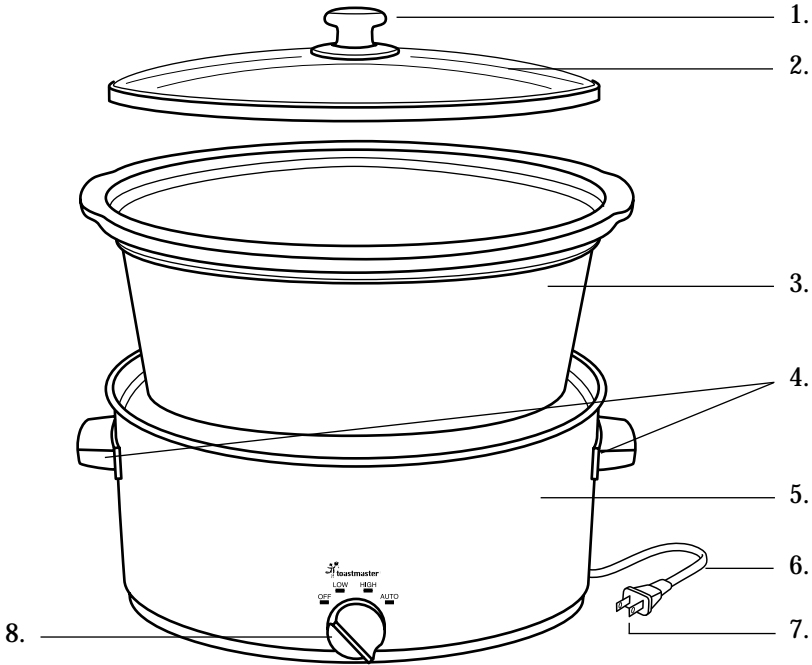

- | | |
|--------------------------------|----------------------|
| 1. Knob (P/N 21400) | 5. Cooking Base |
| 2. Glass Lid (P/N 22020) | 6. Power Supply Cord |
| 3. Stoneware Liner (P/N 21672) | 7. Polarized Plug |
| 4. Handles | 8. Control Knob |

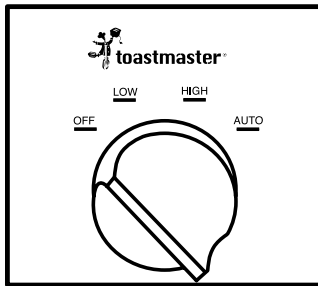

Before First Use

1. Carefully unpack your Slow Cooker and clean, see **CLEANING YOUR SLOW COOKER**.
2. It is necessary to operate the Slow Cooker one time before placing food in the Stoneware Liner. Pour 2 cups of water into the Stoneware Liner and place it inside the Cooking Base. Cover with Glass Lid.
3. Plug into a 120 V, 60 Hz outlet.
4. Turn Control Knob to High position and allow to heat for approximately 20 minutes. You will notice a slight odor; this is normal and should quickly disappear.
5. Turn Control Knob to Off position and allow to cool for 15 minutes.
6. Carefully remove the Stoneware Liner from the cooking Base and discard water from the Stoneware Liner.
7. Rinse Stoneware Liner, dry thoroughly and place back inside the Cooking Base.

Introduction To Slow Cooking

Slow cooking occurs at temperatures just around 200°F. The Slow Cooker can operate at Low all day or night if required. When cooking on a High setting, it is very much like a covered pot on the stove top. Foods will cook on High in about half the time required for Low cooking. Additional liquid may be required as foods do boil on High. To turn the Slow Cooker Off, turn the Control Knob to the OFF position. Always unplug from electrical outlet when not in use.

NOTE: Lid must not be removed while cooking on LOW setting.

How To Use The Auto Feature

The Auto Feature allows you to prepare meals in less time than it would take on Low, but not as quickly as on High. When set on Auto, the Slow Cooker begins cooking on High. Once the High temperature is reached, it then automatically switches to the Low setting. When using the Auto temperature setting, you are able to initially heat the food faster, shortening the cooking time required for Low by approximately 25%.



Using Your Slow Cooker

1. Prepare recipe according to instructions. Place food in Stoneware Liner and cover with the Glass Lid. Do not fill the Stoneware Liner to the brim with food. Always cook with the Glass Lid on and the Stoneware Liner in position. Remember that frequent lifting of the lid during cooking delays cooking time. When cooking a meat and vegetable combination, place the vegetables in the bottom of the Stoneware Liner first. Then add the meat and other ingredients. If the liner is hot, **DO NOT** add cold food and vice versa. The Stoneware Liner cannot stand the shock of sudden temperature changes.
2. Plug into a 120 V, 60 Hz outlet.
3. Turn Control Knob to the desired cooking setting, High, Low or Auto.

CAUTION: COOKING BASE WILL GET VERY WARM DURING COOKING. THIS IS WHERE THE HEATING ELEMENT IS LOCATED. IF NECESSARY TO HANDLE, USE POT HOLDERS OR OVEN MITTS.

4. Cook according to recipe instructions.
5. When cooking time is complete, turn Control Knob to Off position and unplug from outlet.
6. Using oven mitts, carefully remove the Glass Lid by grasping the Knob and lifting the lid slightly away from you. This will allow the steam to escape before removing the lid.
7. Allow a few seconds for all steam to escape. Then, using oven mitts, remove the Stoneware Liner from the Cooking Base.
8. Even when switched OFF, and unplugged, the Slow Cooker remains hot for some time after using; set aside and allow unit to cool before cleaning or storing.

NOTE: If you are moving the Slow Cooker, grasp the unit by the Base Unit Handles; use pot holders or oven mitts.

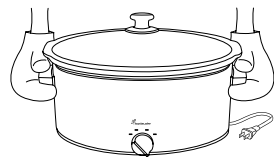

9. Allow to cool completely before cleaning, see **CLEANING YOUR SLOW COOKER**.

Hints For Slow Cooking

- ◆ Meats will not brown during the cooking process. If you desire browning the meat first, heat a small amount of oil in a skillet on the stove and brown meats prior to putting into Stoneware Liner.
- ◆ Whole herbs and spices flavor better in slow cooking than crushed or ground.
- ◆ When cooking in the Slow Cooker, remember that liquids do not boil away like they do in conventional cooking. Reduce the amount of liquid in any recipe that is not designed for a Slow Cooker. The exceptions to this rule are rice and soups. Remember, liquids can always be added at a later time if necessary. If a recipe results in too much liquid at the end of the cooking time, remove the Glass Cover and turn the Control Knob to High. After about 30-45 minutes the amount of liquid should be reduced.
- ◆ Most recipes that call for uncooked meat and vegetables require about 6-8 hours on Low temperature.
- ◆ High fat meats can result in dishes with less flavor. Pre-cooking or browning will help reduce the amount of fat and help to preserve the color. The higher the fat content, the less liquid needed. If cooking meat with a high fat content, use thick onion slices under it so that the meat will not set in and absorb the fat. If necessary, use a slice of bread, a spoon, or a straining spoon to skim off excess fat from top of foods before serving.
- ◆ Foods cut into uniform pieces will cook faster and more evenly than foods left whole such as roast or poultry.

Converting Standard Recipes To Slow Cooking

- ◆ Vegetables such as carrots, potatoes, turnips, and beets require longer cooking times than most meats. Place them on the bottom of the Stoneware Liner and cover them with liquid.
- ◆ If adding fresh milk or yogurt, it should be done during the last 2 hours. Evaporated milk may be added at the start of cooking. If possible, substitute condensed soups for fresh milk or yogurt.
- ◆ Rice and pasta are not recommended for long cooking periods. Cook them separately and then add to the Slow Cooker during the last 30 minutes, or follow Slow Cooker recipe directions.



Caring For Your Slow Cooker

- ◆ Avoid sudden, extreme temperature changes. For example, do not place a hot Glass Lid or Stoneware Liner into cold water or onto a wet surface.
- ◆ Do not use the Ceramic Liner to store food in the refrigerator, and then reheat in the Cooking Base.
- ◆ Avoid hitting the Stoneware Liner and Glass Lid against the faucet or other hard surfaces.
- ◆ Do not use Stoneware Liner or Glass Lid if chipped, cracked, or severely scratched.

User Maintenance Instructions

This appliance requires little maintenance. It contains no user serviceable parts. Do not try to repair it yourself. Any servicing requiring disassembly other than cleaning must be performed by a qualified appliance repair technician.

Cleaning Your Slow Cooker

CAUTION: NEVER IMMERSE COOKING BASE OR CORD IN WATER OR OTHER LIQUID.

1. Always unplug and allow to cool completely before cleaning.
2. Wash Stoneware Liner and Glass Lid in warm, soapy water. If food sticks to the Stoneware Liner, fill with warm, soapy water and allow to soak before cleaning with a plastic scouring pad.
3. Rinse and dry thoroughly.
4. Wipe interior and exterior of the Cooking Base with a soft, slightly damp cloth or sponge. Never use abrasive cleansers or scouring pads to clean the Cooking Base, as they may damage the surfaces.
5. Allow to dry thoroughly before storing. Never wrap the cord tightly around the appliance; keep it loosely coiled.

Recipes

PARTY PIZZA DIP

- 1½ pounds sausage
- 1½ pounds lean ground beef
- 2 medium onions, chopped
- 9 cloves garlic, minced
- 2 pounds shredded mozzarella cheese
- 4 15-ounce cans pizza sauce with cheese

Sauté sausage, ground beef, onion and garlic; drain. Combine all ingredients in Slow Cooker. Cover and heat on High for 2-3 hours, stirring every 30 minutes after the first hour.

NOTE: Do not cook longer on high without stirring because the cheese may begin to stick to bottom.

GREEN CHILI SALSA

- 2¼ pounds lean ground beef
- 2¼ pounds pork sausage
- 1 48-ounce jar chunky salsa sauce
- 3 10-ounce cans condensed cream of chicken soup
- 4 4-ounce cans diced green chilies

Brown ground beef and pork sausage; drain. Combine ingredients in Slow Cooker. Cover and cook on Low for 7-8 hours, stir halfway through cooking time. Serve as a dip.

NEW ENGLAND CLAM CHOWDER

- ½ pound bacon, cut in small pieces
- 2 medium onions, chopped
- 4 medium potatoes, peeled and diced
- 1 teaspoon salt
- 4 cups water
- 4 teaspoons dried basil
- 4 7-ounce cans minced clams with juice
- 4 cups evaporated milk or Half and Half

Sauté bacon and onion; drain. Combine bacon and onions with potatoes, salt and water in Slow Cooker. Sprinkle basil on top. Cover and cook on Low for 9-10 hours. Turn to High and add clams and evaporated milk. Cover and cook on High for 40-50 minutes or until hot.



CHILI

- 1½ pounds lean ground beef
- 1 large onion, chopped
- 2 15-ounce cans Hunt's Ready Tomato Sauce®-special chunky style
- 2 15-ounce cans tomatoes, garlic style
- 2 15-ounce cans chili beans
- 2 teaspoons chili powder
- ¼ cup dill pickle juice

Sauté ground beef and onion; drain. Combine with other ingredients in Slow Cooker. Cover and cook on Low for 5-6 hours or until hot.

HAM AND BEANS

- 1 pound dried Great Northern Beans
- 1 meaty ham bone
- 1 medium onion, chopped
- 1 cup sliced celery
- 1 cup sliced carrots
- 1 tablespoon dried parsley
- 1 bay leaf
- 6 cups water

- ½ teaspoon salt
- ⅛ teaspoon pepper

Soak beans in 6 cups of water overnight; drain. Combine ham, beans, onion, celery, carrots, parsley, bay leaf and water in Slow Cooker. Cover and cook on Low for 11-12 hours or until beans are tender. Remove bay leaf. Remove bone and cut meat into bite size pieces, returning meat to Slow Cooker and add salt and pepper.

BEEF POT ROAST

- 1 5-pound rump, shoulder or chuck roast
- 1½ teaspoons salt
- ¼ teaspoon pepper
- 6 medium potatoes, peeled and quartered
- 8 carrots, cut into 2-inch pieces
- 2 medium onions, halved
- 1 cup water or beef broth

Sprinkle roast with salt and pepper. Place half of vegetables in bottom of Slow Cooker, top with roast, then add remaining vegetables and liquid. Cover and cook on Auto for 11-12 hours or until tender.

PORK WITH PEACH CHUTNEY

- 1 5-6-pound pork loin roast, boneless
- 2 29-ounce cans spiced or plain peaches, drained
- ½ cup raisins
- ½ cup brown sugar
- ½ cup vinegar
- 2 small onions, chopped
- 2 tablespoons prepared mustard
- 1 teaspoon salt

Combine ingredients except roast in blender or food processor to make chutney. Process until coarsely chopped. Place roast in Slow Cooker and pour chutney over roast. Cover and cook on Auto for 9-10 hours or until meat is tender.



SHREDDED PORK BARBECUE

- 1 5-6 pound pork loin roast, boneless
 - 2 15-ounce cans diced tomatoes, drained
 - 1 cup vinegar
 - 2 medium onions, halved and sliced
 - ¼ cup Worcestershire® sauce
 - 6 tablespoons brown sugar
 - 1 teaspoon crushed red pepper flakes
 - 2 teaspoons salt
 - 1 teaspoon pepper
- 2 16-ounce bottles barbecue sauce

Combine ingredients in Slow Cooker. Cover and cook on High for 7-8 hours or until meat is tender. Remove meat and discard bone. Dice or shred meat and serve with barbecue sauce.

SPAGHETTI SAUCE WITH MEAT BALLS

Meatballs

- 2 pounds Italian sausage
- 1 medium onion, chopped
- 2 cloves garlic, minced
- 2 eggs
- 1 teaspoon salt
- ½ teaspoon pepper
- 1 cup bread crumbs
- 4 ounces Parmesan cheese, grated

Sauce

- ½ pound mushrooms, sliced
- 2 medium onions, chopped
- 4 cloves garlic, minced
- 4 15-ounce cans tomatoes, Italian-style
- 4 15-ounce cans tomato sauce
- ½ cup basil leaves
- 1½ teaspoon dried oregano
- 1 teaspoon dried thyme
- ¼ cup sugar
- ½ teaspoon crushed red pepper
- 2 bay leaves

Combine sausage, onion, garlic and egg and form into 1½ inch balls. Place into Slow Cooker. Combine remaining ingredients and pour over meat balls. Cover and cook on Auto for 7-8 hours or until meat is done. Remove bay leaves and serve with pasta.

GARLIC CHICKEN WITH TOMATOES AND POTATOES

- 8 chicken breast halves, boneless-skinless
- 16 small new potatoes, quartered
- 2 15-ounce cans diced tomatoes, Italian-style
- 2 tablespoons fresh minced garlic
- 2 teaspoons salt
- ½ teaspoon pepper
- 2 teaspoons ground mustard

1 cup white wine

¼ cup cornstarch dissolved in 2 tablespoons cold water

Place potatoes in Slow Cooker. Mix together tomatoes, garlic, salt, pepper, dry mustard and wine. Pour over potatoes and add the chicken. Cover and cook on Low for 7-9 hours. Remove potatoes and chicken, leaving the broth. Stir the dissolved cornstarch into the broth. Cover and cook on High for 20-30 minutes, or until thickened. Add chicken and potatoes. Cover and cook on High for an additional 15 minutes or until hot.

STUFFED CHICKEN BREAST WITH CURRY

- ½ pound sausage
- ½ teaspoon ginger
- 1 egg
- 2 tablespoons soy sauce
- ½ cup chopped onion
- ¼ cup chopped parsley
- 2 teaspoons curry powder
- 6 chicken breast halves, boneless-skinless
- ½ teaspoon salt
- ¼ teaspoon pepper
- 1 10-ounce can condensed cream of chicken soup

Mix together sausage, ginger, egg, soy sauce, onion, parsley, and curry and set aside. Slit breast on one side to make a pocket. Season chicken breast with salt and pepper. Stuff each chicken breast with ⅓ of the stuffing mixture, securing with toothpicks and place in Slow Cooker. Pour chicken soup over top of chicken. Cover and cook on Low for 7-9 hours or until done.



THREE VEGETABLE CHEESE BAKE

- 1 16-ounce package frozen broccoli florets
- 1 16-ounce package frozen cauliflower
- 1 16-ounce package frozen Brussels sprouts
- 2 10-ounce cans condensed cream of mushroom soup
- 1½ pounds Velveeta® cheese, cut into 16 pieces

Thaw frozen foods. Place ingredients in Slow Cooker in order listed. Cover and cook on low for 5-6 hours, stirring every 30 minutes after the first hour, or until vegetables are tender.

OLD SETTLER'S BAKED BEANS

- 1 pound lean ground beef
- 1 pound chopped bacon
- 1 large onion, chopped
- $\frac{2}{3}$ cup brown sugar
- $\frac{2}{3}$ cup white sugar
- $\frac{1}{2}$ cup ketchup
- $\frac{1}{2}$ cup barbecue sauce
- 1 teaspoon salt
- 2 tablespoons prepared mustard
- 2 16-ounce cans kidney beans, drained
- 2 16-ounce cans pork 'n beans, drained
- 2 16-ounce cans butter beans, drained

Sauté ground beef, bacon and onion; drain. Place in Slow Cooker. Add sugars, ketchup, barbecue sauce, salt and mustard. Slightly drain beans and stir into other ingredients. Cover and cook on Low for 5-6 hours or until thick and hot.

BAKED APPLES

- 10 large baking apples, Rome or York
- $\frac{3}{4}$ teaspoon nutmeg
- $1\frac{1}{2}$ teaspoons cinnamon
- $\frac{1}{4}$ cup lemon juice
- $\frac{1}{4}$ cup butter, melted
- 6 tablespoons brown sugar

Peel, core, and cut apples in halves. Mix brown sugar, nutmeg and cinnamon together; set aside. Place a layer of apples into the Slow Cooker. Drizzle with lemon juice and butter. Sprinkle with sugar and spice mixture; repeat layers. Cover and cook on Auto for 4-5 hours or until tender.



LIMITED ONE YEAR WARRANTY

Warranty: This Toastmaster® product is warranted to be free from defects in materials or workmanship for a period of (1) year from the original purchase date. This product warranty covers only the original consumer purchaser of the product.

Warranty Coverage: This warranty is void if the product has been damaged by accident in shipment, unreasonable use, misuse, neglect, improper service, commercial use, repairs by unauthorized personnel, normal wear and tear, improper assembly, installation or maintenance abuse or other causes not arising out of defects in materials or workmanship. This warranty is effective only if the product is purchased and operated in the USA, and does not extend to any units which have been used in violation of written instructions furnished with the product or to units which have been altered or modified or to damage to products or parts thereof which have had the serial number removed, altered, defaced or rendered illegible.

Implied Warranties: ANY IMPLIED WARRANTIES WHICH THE PURCHASER MAY HAVE ARE LIMITED IN DURATION TO ONE (1) YEAR FROM THE DATE OF PURCHASE. Some states do not allow limitations on how long an implied warranty lasts, so the above limitation may not apply to you.

Warranty Performance: During the above one-year warranty period, a product with a defect will be either repaired or replaced with a reconditioned comparable model (at our option) when the product is returned to the Repair Center, or the purchase price refunded. The repaired or replacement product will be in warranty for the balance of the one-year warranty period and an additional one-month period. No charge will be made for such repair or replacement.

Service and Repair: Should the appliance malfunction, you should first call toll-free 1 (800) 947-3744 between the hours of 9:00 am and 5:00 pm Central Standard Time and ask for CONSUMER SERVICE stating that you are a consumer with a problem. Please refer to model number TSC6W when you call.

In-Warranty Service (USA): For an appliance covered under the warranty period, no charge is made for service or postage. Call for return authorization (1 800 947-3744).

Out-of Warranty Service: A flat rate charge by model is made for out-of-warranty service. Include \$ 10.00 (U.S.) for return shipping and handling. We will notify you by mail of the amount of the charge for service and require you to pay in advance for the repair or replacement.

For Products Purchased in the USA, but Used in Canada: You may return the product insured, packaged with sufficient protection, and postage and insurance prepaid to the USA address listed below. Please note that all customs duty / brokerage fees, if any, must be paid by you and we will require you to pay the cost of customs duty / brokerage fees to us in advance of our performing any service.

Risk During Shipment: We cannot assume responsibility for loss or damage during incoming shipment. For your protection, carefully package the product for shipment and insure it with the carrier. Be sure to enclose the following items with your appliance: any accessories related to your problem, your full return address and daytime phone number, a note describing the problem you experienced, a copy of your sales receipt or other proof of purchase to determine warranty status. C.O.D. shipments cannot be accepted.

To return the appliance, ship to:

Attn: Repair Center
Toastmaster Inc.
708 South Missouri Street
Macon, MO 63552

To contact us, please write to or call:

Toastmaster Inc.
P.O. Box 6916
Columbia, MO 65205-6916
1 (800) 947-3744
Email: consumer_relations@toastmaster.com
www.toastmaster.com

Limitation of Remedies: No representative or person is authorized to assume for us any other liability in connection with the sale of our products. There shall be no claims for defects or failure of performance or product failure under any theory of tort, contract or commercial law including, but not limited to negligence, gross negligence, strict liability, breach of warranty and breach of contract. Repair, replacement or refund shall be the sole remedy of the purchaser under this warranty, and in no event shall we be liable for any incidental or consequential damages, losses or expenses. Some states do not allow the exclusion or limitation of incidental or consequential damages, so the above limitation or exclusion may not apply to you.

Legal Rights: This warranty gives you specific legal rights, and you may also have other rights which vary from state to state.

Keep Dated Sales Receipts for Warranty Service.

Keep this booklet. Record the following for reference:

Date purchased _____

Model number _____

Date code (stamped on bottom) _____

EVERYBODY EATS. It's a fact of life.

But sometimes preparing
meals can become a chore.

That's why TOASTMASTER has been invited
into millions of kitchens just like yours
so we can HELP YOU MASTER your
mixing, baking, grilling, toasting,
brewing, heating and serving
tasks WITH EASE AND STYLE.

The TOASTMASTER name stands for a
CELEBRATION of INNOVATION designed
to serve your life and keep you
COOKIN' IN STYLE.





toastmaster®

- *Removable crock*
- *See-through glass lid*
- *Three temperature settings*
- *Power indicator light*



Questions

Call toll free 1-800-947-3744

Monday – Friday, 8:00 a.m. - 5:30 p.m. CST

www.toastmaster.com