



**Models:
E17UAC
E17UAC-INS
E6UAC
E6UAC-INS**

TOASTMASTER

Revised: 31 Dec 2010

**Model E17UAC
Warming Cabinet**

General Information 1

Unpacking 1

Maintenance 1

Operating 2

Parts List for Power Drawer 3

Parts List for Cabinet 4

Drawer Assembly 5

Electrical Schematic 6

Service Specifications 7

Warranty 8

GENERAL INFORMATION

The E17UAC or E6UAC will hold food hot at a constant temperature, and supply humidity for proofing when the application applies.

This cabinet is not a cooking appliance.

UNPACKING -

Examine the interior of the unit to make sure all packing materials are removed before the unit is plugged into an electrical outlet. Examine the interior and exterior to determine whether any damage was incurred during delivery. If so, notify the carrier immediately to file a damage claim. All Wilder equipment is carefully tested and inspected prior to shipment. When accepted for delivery by carrier, the responsibility for safe arrival at the destination is assumed by the carrier.

CAUTION:

Should any damage be found, do not attempt to operate the unit. Call your dealer immediately to arrange for service.

MAINTENANCE -

The equipment has been designed to require minimum maintenance and has been constructed to meet National Sanitation Foundation and U.S. Public Health Service Standards.

Non-toxic chemical cleaners or mild detergents are recommended for cleaning of fixtures. Do not use steel wool of any kind. Steel wool particles will work into the grains of the metal causing corrosion. Also, these particles can cause a health hazard. Should scouring be required, use a non-abrasive type of cleaner. Do not use caustic solutions on your equipment. Hosing or steaming should not be necessary to keep these fixtures clean and sanitary. Do not allow water or steam to come into contact with electrical components.

CAUTION:

Be sure to disconnect power source before cleaning and servicing the unit. Liability for improper or careless use is the responsibility of the equipment owner or persons servicing the unit, including the authorized service agent.

OPERATING INSTRUCTIONS

1. Push ON/OFF rocker switch to “ON” position.
2. Push HEAT/PROOF switch to HEAT for heating.
3. Turn HEAT thermostat knob fully clockwise for pre-heat.
4. Allow 45 minutes for pre-heating, then turn thermostat to desired setting.
5. For proofing, push HEAT/PROOF switch to PROOF.
6. Adjust the heat and humidity thermostat knobs to control desired temperature and humidity. Allow 45 minutes for pre-heating.

NOTE: The internal air circulation blower will operate continuously when the power switch is turned “on”.

HEAT THERMOSTAT -

The controlling range is 80°F to 175°F. The dial has numbers 1 through 9 that do not relate to specific calibrated temperatures. Temperature settings must be obtained through familiarization with the unit. The dial has an “off” position to turn heater unit off.

HUMIDITY THERMOSTAT -

To control humidity range from 30% to 100% humidity, settings must be obtained through familiarization with the unit. The dial also has an “off” position to turn heater unit off.

To maintain low heat range between 85°F and 100°F, switch to proof mode and adjust heat knob to desired heat range. Allow 45 minutes to pre-heat in proof cycle.

PARTS LIST FOR E17UAC

<u>ITEM</u>	<u>DESCRIPTION</u>	<u>PART NUMBER</u>
1	Heat/Proof Switch	2E-50-1357
2	Thermostat (Heat)	2T-66-1158
3	Thermostat (Proof)	2T-66-1158
4	Blower and Motor Assy	2U-WP-6FANS30P
5	Pilot Light	2J-50-0029-A
6	Main Power Switch	2E-50-1355
7	Snap Disc	2T-66-1150
8	Pan Slide	25-0010-C
9	800W Heater Element, Export Models (50Hz only)	2N-60-0200
10	1100W Heater Element	2N-60-0201
11	600W Heater Element	2N-6WH0001P
12	600W Water Pan Heater Element	2N-6FME755P
13	Proof and Heat Control Knob	2R-50-0726
14	Corner Bumpers	2R-4FMBC01P
15	5" Caster E17UAC	305SSPW
16	3" Caster E6UAC	2P-50-1388
17	Lexan Door Assy E17UAC (mfg before 10/2008)	R2-WASSY043
	WASSY043 Door Gasket	2I-70-0359A
17	Lexan Door Assy E17UAC (mfg after 10/2008)	R2-WASSY058
	WASSY058 Door Gasket	2I-70-0363A
17	Lexan Door E17UAC-INS	R2-WASSY058
17	Lexan Door E6UAC	R2-WASSY046
17	Lexan Door E6UAC-INS	WASSY048
18	S/S Hinge	2F-50-1209-A
17	Cord 5-15P	2E-50-1275
17	Cord 5-20P	2E-50-0375
--	Assy, Water pan No-Elements	R2-WASSY082
--	Handle & Magnet Latch (on door)	2R-50-1319
--	Catch Bracket (on cabinet)	R2-06-0160

Electrical Schematic E17UAC Heater Proofer

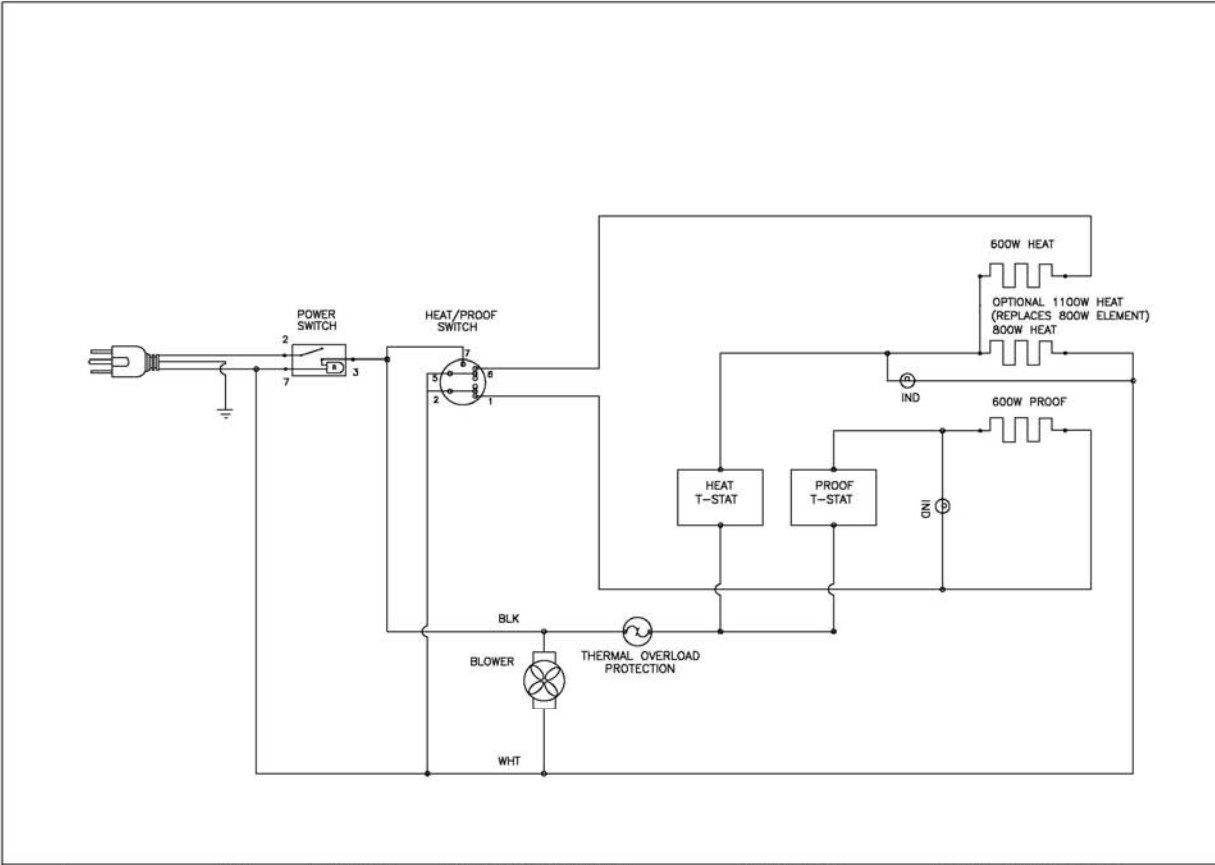

NWJ	NU-VU Food Service Systems 5600 13th STREET MENOMINEE, MICHIGAN 49858	REV.	DESCRIPTION	CHANGED BY	DRAWN BY: CTC	VOLTAGE: 120	MODEL #: E6UAC, E17UAC
		A			CHECKED:	PHASE: SINGLE	CUSTOMER
			DATE	DATE: 12-13-06	WATTAGE:		
			09-18-06	BOM FILE #	CONTROLS: MECHANICAL	DWG. NO. 019-0311	

SERVICE SPECIFICATIONS – E17UAC

The Heater Proofer is an aluminum transport cabinet with heaters to function as a hot food holding cabinet, and/or as a proofing cabinet.

The heater, or heat drawer, is slid into place on the floor of the cabinet. An electrical socket on the back of the drawer is provided to accept the supplied power cord, which is plugged into the drawer through an access hole in the back of the cabinet.

The main power switch on the front of the drawer, when switched “ON”, will turn on the light in the switch and turn on the air circulating fan in the drawer. The circulating fan will operate continuously while the unit is “ON”.

The thermostat control knobs are mounted to the left and right of the heat/proof switch. The left thermostat knob controls the heat in the cabinet from 1 (low heat: approximately 80°F) to 9 (high heat: approximately 175°F). The right thermostat knob controls the humidity from 1 (approximately 20% relative humidity) to 9 (in excess of 100% relative humidity). Average setting will be approx. 6 (approximately 85% relative humidity).

TROUBLE SHOOTING -

Caution: Before disassembling unit, electrical power must be disconnected by unplugging the unit. Failure to unplug the unit prior to servicing may result in electrical shock.

Each unit is shipped with an instruction manual to be used as a reference guide for all service areas. The manual shows a picture of the drawer, showing the location of electrical components and a description of each. If the unit does not operate correctly, or malfunctions for any reason, the following checklist should provide a solution.

- 1) Check to make sure cord set is firmly plugged into the wall outlet.
- 2) Check circuit breaker of wall outlet and reset if necessary.
- 3) Remove heat drawer from cabinet. Remove bottom cover of drawer. Visually inspect for:
 - a) Loose or disconnected wires
 - b) Black marks or burning on any components
 - c) Loose heating elements.
- 4) If any burn marks or discoloration of wires is note on any components along with all wires attached to damaged components must be replaced.
- 5) If heater element is loose, or if it has broken loose from mounting tabs, the wires will short out on the Metal, causing permanent damage. Both the element and main power switch (with wires on switch) must be replaced.



EQUIPMENT WARRANTY

NU-VU Food Service Systems and Toastmaster Manufacturing warrant to the initial purchaser that all NU-VU and Toastmaster products shall be free from defects in material or factory workmanship, under ordinary use for the purpose for which it is designed, for a period of one (1) year from the date of shipment from the manufacturing facility. At our option, any equipment will be repaired or a replacement part furnished FOB our factory.

Return of component parts will not be accepted for credit without prior authorization by our service department, and then contingent upon our inspection. This Warranty will not apply if, after examination, it is determined that the equipment or any part thereof is found to be defective through purchaser's lack of responsibility for maintenance or storage, shipping damage, accidental damage by moving or otherwise, improper voltage, misapplication or alteration by other than ourselves, or use of unauthorized parts. This Warranty does not apply to glass, light bulbs, or gaskets.

This Warranty does not apply if payment has not been received for the equipment at the time a claim is made or if the NU-VU or Toastmaster serial number has been removed.

WARRANTY EXCLUSIONS AND LIMITATIONS

This Warranty applies only within the United States and Canada. ANY IMPLIED WARRANTY OF MERCHANTABILITY OR FITNESS FOR A PARTICULAR PURPOSE IS HEREBY SPECIFICALLY DISCLAIMED BY NU-VU/Toastmaster. There are no warranties, expressed or implied, which extend beyond the description on the face thereof.

This warranty does not cover, and NU-VU/Toastmaster shall not under any circumstances be liable for, any incidental, consequential or other damages (such as injury to persons or property, loss of time, inconvenience, loss of use, loss of business or profits, or other matters not specifically covered) arising in connection with the use of, inability to use, or failure of these products.

Star International Holding Inc. Company
10 Sunnen Dr
St. Louis, MO 63143
Phone: 800-264-7827
Fax: 314-781-2714