

# TOASTESS®

## PARTY GRILL AND RACLETTE



Instruction Booklet  
Model: TPG-457

## IMPORTANT SAFEGUARDS

When using electrical appliances, basic safety precautions should always be followed including the following:

1. Read all instructions.
2. Do not touch hot surfaces. Use handles or knobs.
3. To protect against electrical hazards, do not immerse cord, plugs, or the appliance in water or other liquid.
4. Close supervision is necessary when any appliance is used by or near children.
5. Unplug from outlet when not in use and before cleaning. Allow to cool before putting on or taking off parts, and before cleaning the appliance.
6. Do not operate any appliance with a damaged cord or plug or after the appliance malfunctions, or has been damaged in any manner. Return appliance to Toastess for examination, repair or adjustment. See Warranty.
7. The use of accessories or attachments not recommended by Toastess may cause hazards.
8. Do not use outdoors.
9. Do not let cord hang over edge of table or counter, or touch hot surfaces.
10. Do not place on or near a hot gas or electric burner, or in a heated oven.
11. Extreme caution must be used when moving an appliance containing hot liquids.
12. Always attach plug to appliance first, then plug cord into the wall outlet. To disconnect, turn any control to 'OFF', then remove plug from wall outlet.
13. Do not use appliance for other than intended use.
14. Do not leave unit unattended while in use.

**SAVE THESE INSTRUCTIONS**  
HOUSEHOLD USE ONLY

## POLARIZED PLUG

This appliance has a polarized plug (one blade is wider than the other). To reduce the risk of electric shock, this plug will fit in a polarized outlet only one way. If the plug does not fit fully in the outlet, reverse the plug. If it still does not fit, contact a qualified electrician. Do not modify the plug in any way.

## INTRODUCTION

The Party Grill & Raclette is a enjoyable and healthy way of cooking meats, fish and vegetables... in minutes! Well-known in Europe, the art of cooking raclette encourages you and your guests to create simple yet delicious meals together. Delight in fresh foods hot off the grill while enjoying the fun, party atmosphere that this Party Grill & Raclette creates. Explore the wonderful versatility of this product as you and your guests prepare grilled meats, raclette... even appetizers such as cheese on potatoes, toast, or grilled tomatoes can be a meal that is as unique as the person preparing it. It's easy to use and a snap to clean. Try the recipes included as an introduction to this exciting method of cooking... and have fun!

## DESCRIPTION OF PARTS

1. Reversible Plate
2. Grill Supports
3. Raclette Pans
4. Lower Plate/Base
5. Temperature Control Dial
6. Indicator Light
7. Power cord
8. Handles
9. Spatulas

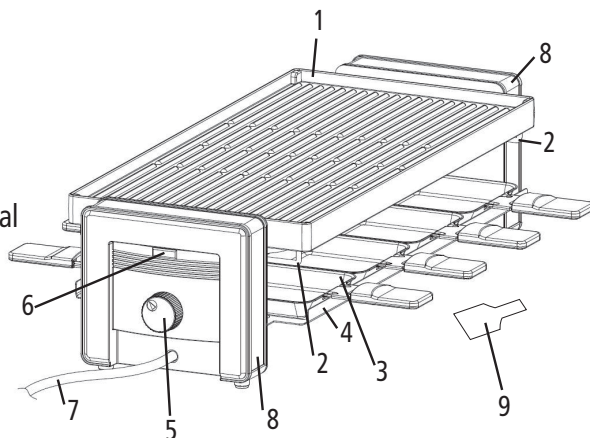

## BEFORE FIRST USE

1. Remove all packaging.
2. Wash the Grill Plate, Raclette Pans and Spatulas in warm soapy water. Rinse and dry.
3. Wipe the Lower Plate/Base of the unit with a damp cloth. Dry.  
**NOTE: DO NOT WIPE ELEMENT. DO NOT IMMERSE UNIT IN WATER OR ANY OTHER LIQUID.**
4. Place the Lower Plate/Base on a flat level heat resistant surface close to a 120 volt A.C. wall outlet. **IMPORTANT:** The Grill must be at least 6" (15cm) away from walls, curtains, etc. and in a well ventilated area.
5. Season the non-stick Grill Plate and Raclette Pans (inside only) by wiping them with a paper towel moistened in 1 tbsp. (15 ml) of good quality vegetable oil. Let the oil remain on the surface.
6. Place the Grill Plate on top of the Grill Plate Supports. Place the Raclette Pans under the element on the Lower Plate.
7. Turn the Temperature Control Switch to the MAX position and heat for approximately 10 minutes. This will burn off any manufacturing oils still on the Grill. **NOTE:** The Grill may smoke during this process. This is normal and will not last more than a few minutes.
8. Turn off the Grill by turning the Temperature Control Dial to '•' and unplugging the Power Cord from the wall outlet or follow the directions in the HOW TO USE section.

## HOW TO USE

1. Place the Base on a flat level surface. Turn the Temperature Control Dial to '•' position. **NOTE:** Ensure that the area being used is well ventilated. Be careful of splattering fat or juice when grilling foods.
2. Position the Reversible Grill Plate over the Element on the Grill Supports. Use the smooth side for warming, preparing fondue or breakfast foods, etc. Use the ridged side for grilling meats, fish or vegetables.
3. Place Raclette Pans under the element so they rest on the Lower Plate.
4. Plug the Power Cord into a 120 volt AC wall outlet.

5. Turn the Temperature Control Dial to the MAX position and preheat for about 10 minutes. When cooking turn the Temperature Control Dial between '•' and MAX positions. These settings reflect temperatures ranging from low to high respectively. The temperature may be adjusted during cooking for optimal cooking results.
6. The Raclette Pans can be moved on and off the Lower Plate as food is cooked and served. **NOTE:** Be sure to place the hot raclette pans on a heat-resistant surface when removed from the Grill.
7. Use smooth-edge utensils, preferably wooden or plastic. The spatulas, included with the Grill, are specially designed to remove food from pans easily and without sticking. **NOTE:** Do not cut food on the Reversible Plate or in the Raclette Pans as this may damage the coating.
8. When cooking is complete, turn the Temperature Control Dial to the '•' position and remove plug from wall outlet.
9. Do not move the unit until it is completely cool. Remove the Raclette Pans before moving to prevent them from falling from the Lower Plate.

## HELPFUL HINTS

- Before preheating the Grill Plate, use a paper towel moistened in 1 tbsp. (15 ml) of good quality vegetable oil and spread on cooking surface of Grill Plate and inside Raclette Pans.
- Always preheat the Grill at the MAX temperature setting for 10 minutes.
- DO NOT use metal utensils to place food on or remove food from the Grill Plate. This may scratch the non-stick Grill Plate.
- Use the Spatulas included with the appliance to remove food from the Raclette Pans.
- Never cut food directly on the Grill Plate or in the Raclette Pans.
- When using the Raclette Pans on top of the Grill Plate, place gently so they do not scratch the Grill Plate.

## GENERAL USE GUIDE

### Smooth-Faced Plate

USE	FOOD	GUIDELINES
Warming Tray	<ul style="list-style-type: none"> <li>Any type of food or leftovers such as pasta, soups, casseroles, etc.</li> </ul>	<ul style="list-style-type: none"> <li>Place food in a heat-resistant plate or pot and warm to desired temperature</li> </ul>
Fondue	<ul style="list-style-type: none"> <li>Cheese, chocolate and Chinese fondue.</li> </ul> <p><b>WARNING: Do not use with hot oil fondue.</b></p>	<ul style="list-style-type: none"> <li>Can accommodate 2 aluminum or enameled steel pots. (Approximately 7" / 175mm)</li> <li>Preheat pot on stove top or fondue burner before placing on Plate.</li> <li>Place a piece of aluminum foil under the fondue pot to avoid damaging the non-stick coating.</li> </ul>
Griddle	<ul style="list-style-type: none"> <li>Pancakes, eggs, etc.,</li> <li>Frying or browning meats, poultry, fish, etc.</li> </ul>	<ul style="list-style-type: none"> <li>Pour batter or eggs directly onto plate and cook to desired taste</li> <li>Brown meats with a small amount of vegetable oil.</li> </ul>

### Ridged Plate

USE	FOOD	GUIDELINES
Grilling	<ul style="list-style-type: none"> <li>Meats, fish, poultry, seafood and vegetables.</li> </ul>	<ul style="list-style-type: none"> <li>Spread a little vegetable oil on the Grill Plate. Preheat. Place food on Grill Plate.</li> <li>Grill food according to taste. Turn food from time to time.</li> <li>Grilling time depends on type of food, initial temperature and thickness.</li> </ul>

## Raclette Pans

USE	FOOD	GUIDELINES
Broiling	<ul style="list-style-type: none"> <li>• Raclette cheese, raw eggs, breads, hors d'oeuvres.</li> <li>• Thinly sliced meats or fish.</li> </ul>	<ul style="list-style-type: none"> <li>• Place food in Raclette Pans.</li> <li>• Position Pans on Lower Plate and broil to taste, verifying every now and then.</li> <li>• Melted cheese can be spread on grilled food or bread.</li> </ul>
Desserts	<ul style="list-style-type: none"> <li>• Fruits (flambé bananas, fruit gratins, etc.)</li> <li>• Thinly sliced cake sprinkled with liqueur.</li> </ul>	<ul style="list-style-type: none"> <li>• Place food in Raclette Pans.</li> <li>• Cut fruit into slices.</li> <li>• Sprinkle fruit or cake with sugar and position Pans on Lower Plate.</li> </ul>

## CARE AND CLEANING

1. Turn the Temperature Control Dial to the '●' position. Remove the plug from the wall outlet and allow the appliance to cool completely before cleaning.
2. Remove the Reversible Plate, Raclette Pans and Spatulas from the appliance. The Reversible Plate and Raclette Pans are dishwasher safe and can be placed in the dishwasher or can be washed in hot soapy water along with the Spatulas. Rinse and Dry.
3. Wipe the Lower Plate/Base with a soft damp cloth. Dry.  
**IMPORTANT NOTES:**
  - **DO NOT WIPE THE ELEMENT**
  - **DO NOT USE STEEL WOOL OR ABRASIVE CLEANERS ON ANY PART OF THE APPLIANCE.**
  - **DO NOT IMMERSE THE LOWER PLATE/BASE OR THE PLUG IN WATER OR ANY OTHER LIQUID**
4. To protect the appliance's non-stick coating, wipe the Reversible Plate and enameled Raclette Pans with a paper towel moistened with one tablespoon of cooking oil. It is recommended to repeat this step after every use.

## RECIPES

There is an enormous choice of suitable meats, ranging from small sausages to brochettes, chicken and fish, which can all be cooked on the Grill Plate. Smaller pieces of food can also be cooked in the Raclette Pans. Please use the following recipes as a guide.

## Raclette-Style Cheese

Use this simple recipe for making raclette cheese. Melt the blend of cheeses in the Raclette Pans and spread on crusty bread or grilled vegetables.

- 1-1/2 cups (375 ml) shredded processed\* Gruyere cheese
- 1 cup (250 ml) shredded Gouda Cheese
- 1 tbsp (15 ml) snipped fresh basil or oregano
- 2 tsp. (10 ml) Dijon-style mustard
- 1 tsp. (5 ml) white wine
- Worcestershire sauce, to taste
- Tabasco sauce, to taste
- Blanched cauliflower and/or broccoli flowerets
- Halved tiny new potatoes
- Pita bread wedges

In a small mixing bowl combine cheeses; let stand to soften. Add basil or oregano, mustard, wine and Worcestershire and Tabasco sauces. Beat with an electric mixer on low speed until well combined; (mixture will be crumbly). Form into a ball about 4" (10 cm) round by 1 inch (2.5 cm) high. Wrap in clear plastic wrap. Chill several hours or overnight.

Preheat the Grill. Unwrap cheese round and cut into wedges. Place the wedges in Raclette Pans. Place Pans on Lower Plate and melt cheese until softened and heated through. Check often to make sure the cheese doesn't over-melt (the cheese shouldn't lose its shape or start to run).

Grill vegetables and potatoes on the Grill Plate while cheese is melting. Serve cheese with warm vegetables and pita bread.

\*It is important to use processed cheese. Processed cheese melts smoothly, giving an acceptable texture.

## Veal Medallions with Camembert

- 4 veal medallions (1/2"/12mm thick)
- 4 slices Camembert cheese
- Salt and pepper, to taste

Preheat the Grill. Season medallions with salt and pepper. Place medallions on the Grill Plate and cook until desired doneness. Place cooked medallions in Raclette Pans. Place a slice of cheese on each of the medallions and place Raclette Pans on the Lower Plate until cheese is melted. Serve.



### King-Sized Prawns with Dill

6 – 8 raw, shelled prawns

Marinade:

juice of 1 lemon  
 4-5 tbsp. (60-75 ml) oil  
 1 tsp (5 ml) sea salt  
 1 tsp. (5 ml) chopped dill  
 white pepper, to taste

In a medium size bowl mix all of the marinade ingredients. Marinate prawns in this mixture for 1 – 2 hours.

Preheat Grill. Place prawns directly on Grill Plate turning them over occasionally until done.

### Provençale Tomato Halves

medium sized tomatoes  
 chopped parsley  
 crushed garlic  
 fine bread crumbs  
 olive oil

Preheat Grill. Halve tomatoes. Place each half in a Raclette Pan and add a very small amount of water. Place pans onto top of Grill Plate and steam for about 20 minutes, turning once or twice. Mix chopped parsley, crushed garlic, fine breadcrumbs and olive oil into a thick paste. Spread on top of the tomatoes and place Raclette Pans on the Lower Plate for approximately 5 minutes.

### Pears Savoy-Style

Pears, thinly sliced  
 butter  
 sugar  
 cream

Preheat Grill. Peel, halve and core pears then thinly slice. Melt butter in Raclette Pans on the Lower Plate. Arrange pears in a fan shape and sprinkle with sugar. Place Raclette Pans on top of Grill Plate and cook for a few minutes until pears turn soft. Pour some cream over them and place Raclette Pans on the Lower Plate. Cook gently until the sauce is slightly caramelized.

## Fondue Scampi

1 clove	garlic, cut in half
13 oz. (364 g)	Gruyère cheese
7 oz. (196g)	Emmentaler cheese
1 tsp. (5 ml)	cornstarch
1-1/2 cups (375 ml)	Rosé wine
1 tsp. (5ml)	lemon juice
1 shot	Kirsch
1 tsp. (5 ml)	dried dill
10 oz. (280 g)	frozen (cooked and shelled) shrimp
	Crusty French or Italian bread, cut into bit sized pieces

Thaw shrimp.

Set the temperature control to MAX and preheat the grill.

While the grill is preheating, rub the inside of a fondue pot with garlic. Put coarsely grated cheeses, cornstarch, Rosè and lemon juice into the fondue pot. Stir and heat on stove top – do not boil. Stir until smooth then add Kirsch and dill. Stir until smooth.

Lower Grill Temperature Control to a medium setting and place fondue pot on the smooth-faced side of the Reversible Plate to keep the fondue warm. Dip bread pieces and shrimp into fondue.

## French Toast

4	eggs
1/2 tsp. (3 ml)	salt
3 tbsp. (45 ml)	sugar
1-1/3 cups (335 ml)	milk
8 slices	day old bread
1 tbsp. (15 ml)	unsalted butter – divided

Preheat Grill for 10 minutes with the smooth grill plate facing up. Turn the Temperature Control to a medium setting.

While the grill is preheating, combine eggs, salt, sugar and milk in a shallow baking dish. Blend thoroughly.

Put a small amount of butter on the grill plate and spread with a plastic or wooden spatula.

Soak bread in egg mixture, turning once to coat both sides. Place on the grill plate and cook until golden brown, turning once so both sides are cooked. Serve immediately or place in an oven to keep warm. **NOTE:** Do not soak bread until ready to cook or the bread will break apart.

A short supply cord is provided to reduce the hazards of becoming entangled in or tripping over a long cord. Extension cords may be used if care is exercised in their use. If an extension cord is used, the marked electrical rating of the detachable power-supply cord or extension cord should be at least as great as the electrical rating of the appliance. If the appliance is of the grounded type, the extension cord should be of a grounded 3-wire cord. The extension cord should be arranged so that it will not drape over the counter top or table top, where it can be pulled on by children or tripped over.

## LIMITED WARRANTY

Toastess International warrants that this appliance shall be free from defects in material and workmanship for a period of one year from the date of purchase. During this 'in-warranty' period, defective products will be repaired or replaced at the discretion of the retailer and/or Toastess International. This warranty covers normal domestic usage and does not cover damage which occurs in shipment or failure which results from alteration, accident, misuse, abuse, glass breakage, neglect, commercial use or improper maintenance.

A defective product should be returned to the original place of purchase within the retailer's stipulated return/exchange period\*. If you are unable to have a defective product replaced under warranty by the retailer, please check our website at "www.toastess.com" for the service centre nearest you or you may contact us for assistance by mail, e-mail, fax or telephone as listed below.

To ensure prompt 'in-warranty' service, securely package and return the product to us prepaid. Be sure to include the original proof of purchase and a description of the defect along with your address and zip/postal code.

For repairs not covered by the warranty, please contact us for assistance.

# TOASTESS®

## TOASTESS INTERNATIONAL

Customer Service Department

81A Brunswick

Dollard-des-Ormeaux

Québec, Canada H9B 2J5

E-mail: [info@toastess.com](mailto:info@toastess.com)

Fax: 514-685-8300

Tel: 514-685-2820

\* Return/exchange policies at each retailer vary and may differ from the Toastess International 1 year limited warranty period.