

Tanaka



Parts Catalog



Chain Saw

Model: ECS-330

All Units Before Ser. # L269580

FIG.1 ENGINE

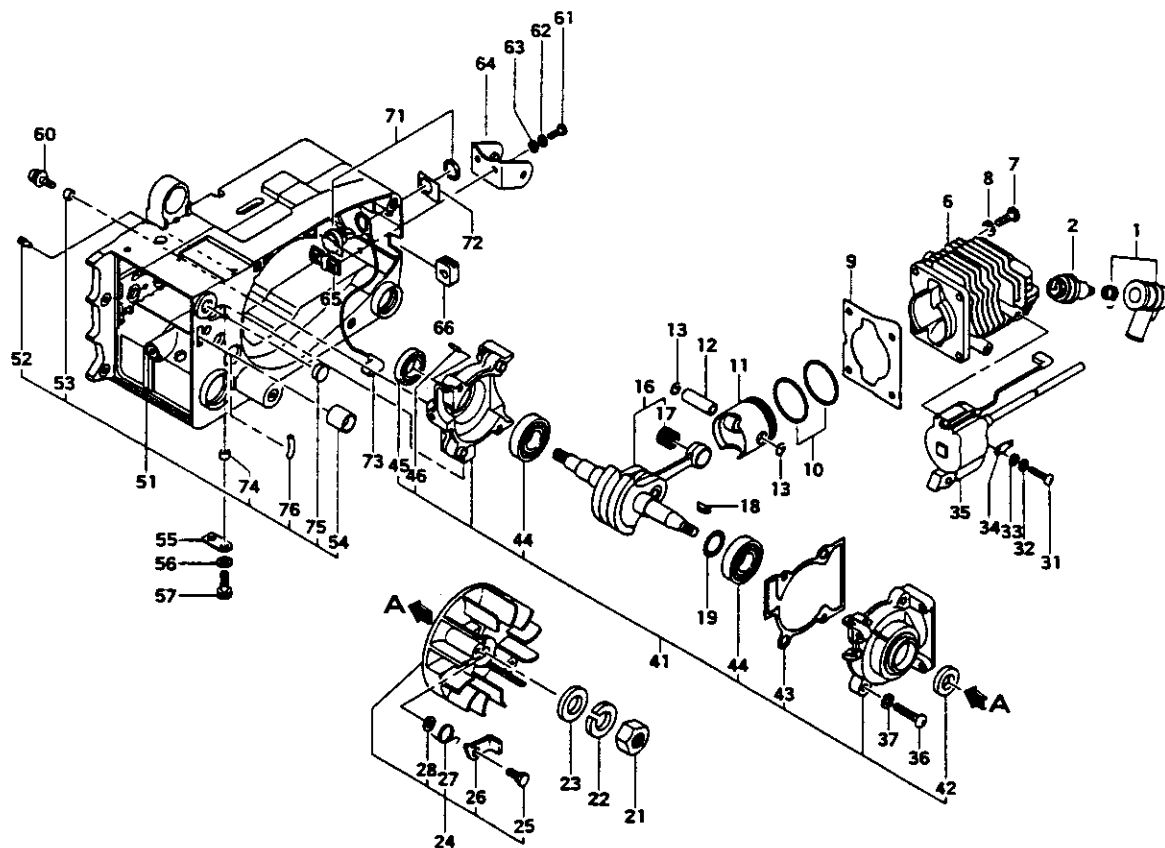

REF. NBR	PART NBR	PART NAME	Q'TY	SERIAL NBR	REMARKS
1-001	157-11666-900	SPARK PLUG CAP ASS'Y	1		
1-002	018-01805-200	SPARK PLUG CJ8	1		
1-006	002-01730-200	CYLINDER	1		
1-007	990-11050-181	SCREW 5X16	4		
1-008	992-10050-012	S. WASHER 5	4		
1-009	017-01730-200	CYLINDER GASKET	1		
1-010	041-01730-200	PISTON RING	2		
1-011	031-01730-200	PISTON	1		
1-012	037-01400-200	PISTON PIN	1		
1-013	039-00000-201	PISTON PIN CIRCLIP	2		
1-016	046-01700-801	CRANK SHAFT COMP.	1		
1-017	999-82091-325	NEEDLE BEARING F-910	1		
1-018	068-10100-200	WOOD-RUFF KEY 3X13X4.5	1		
1-019	071-02007-200	CRANK SHAFT SHIM 0.05	V		
1-019	071-02007-210	CRANK SHAFT SHIM 0.10	V		
1-019	071-02007-220	CRANK SHAFT SHIM 0.15	V		
1-019	071-02007-230	CRANK SHAFT SHIM 0.20	V		
1-021	066-00000-200	FLYWHEEL NUT 12	1		
1-022	992-10070-012	S. WASHER 7	1		
1-023	992-01070-011	WASHER 7	1		
1-024	155-20507-900	MAGNETO ROTOR ASS'Y	1		
1-025	793-10200-202	STEP BOLT	2		
1-026	788-01700-200	STARTER PAWL	2		
1-027	790-01700-200	STARTER PAWL SPRING	2		
1-028	182-01700-200	SPECIAL WASHER	2		
1-031	990-11040-181	SCREW 4X18	2		
1-032	992-10040-012	S. WASHER 4	2		
1-033	992-00040-011	SMALL WASHER 4	2		
1-034	205-01700-200	TAB	1		
1-035	167-20507-800	IGNITION COIL COMP.	1		

-To be cont'd-

FIG. 1 ENGINE

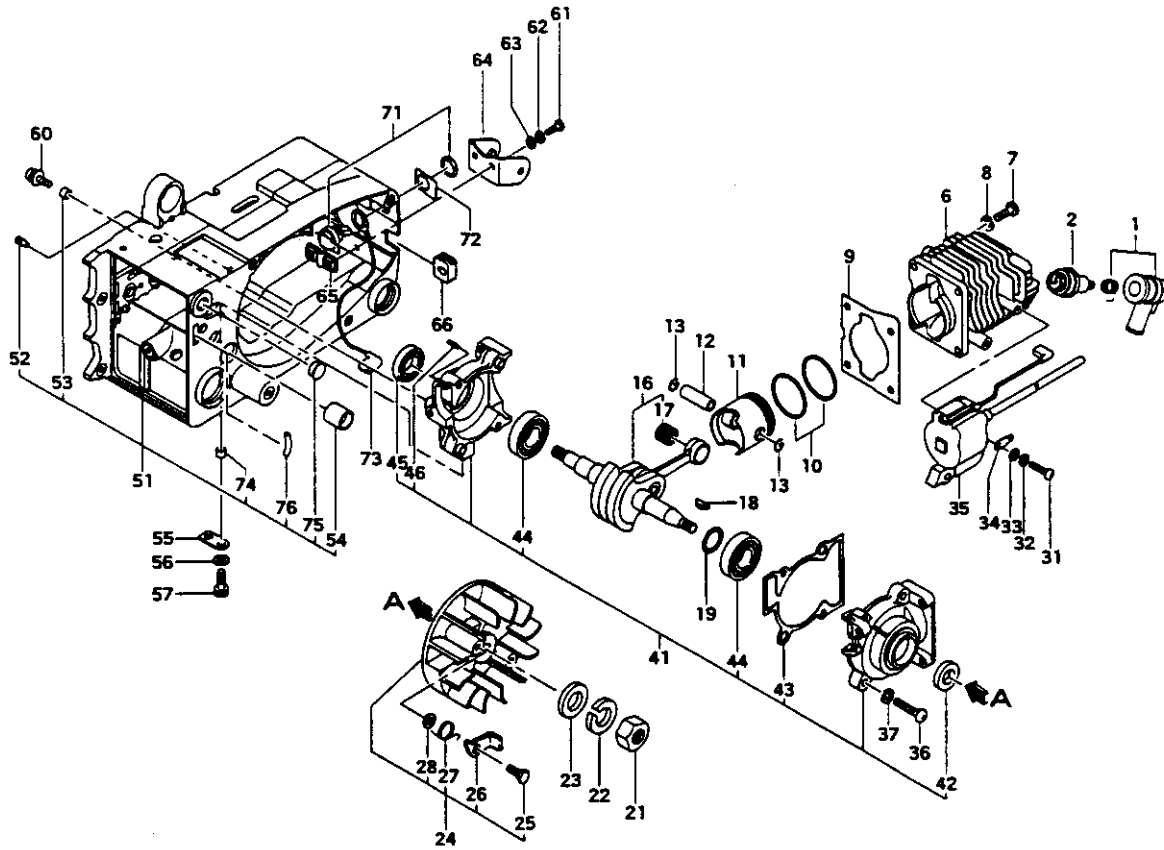

REF. NBR	PART NBR	PART NAME	QTY	SERIAL NBR	REMARKS
1-036	990-11050-251	SCREW 5X25	4		
1-037	992-10050-012	S.WASHER 5	4		
1-041	072-01730-900	CRANK CASE ASS'Y	1		
1-042	999-86122-200	OIL SEAL 12227	1		
1-043	090-01730-200	CRANK CASE GASKET	1		
1-044	999-61620-200	BALL BEARING #6202	2		
1-045	999-66152-500	OIL SEAL 15257	1		
1-046	999-05250-980	NEEDLE ROLLER 2.5X9.8	1		
1-051	560-32758-910	ENGINE CASE ASS'Y	1		
1-052	562-04080-200	AIR VENT VALVE B	1		
1-053	031-32710-210	COLLAR	2		
1-054	629-11800-900	TANK INNER CAP ASS'Y	1		
1-055	874-32710-210	HOLDER PLATE B	1		
1-056	992-10060-012	S.WASHER 8	2		
1-057	990-51060-203	HEX. HOLE BOLT 6X20	2		
1-060	994-15050-185	SCREW 5X18/PS	2		
1-061	990-11040-121	SCREW 4X12	2		
1-062	992-10040-012	S.WASHER 4	2		
1-063	992-00040-011	SMALL WASHER 4	2		
1-064	243-32750-201	DAMPER REAR STAY	1		
1-065	873-32750-800	HOLDER PLATE A COMP.	1		
1-068	203-10000-200	PRIMARY CORD GROMMET	1		
1-071	182-01570-900	STOP SWITCH ASS'Y	1		
1-072	183-01300-200	SWITCH NAME PLATE	1		
1-073	274-01710-800	EARTH CORD COMP.	1		
1-074	031-32750-200	COLLAR	2		
1-075	052-32718-200	GROMMET A	1		
1-076	700-12004-026	GROMMET	1		

FIG.2 AIR CLEANER & MUFFLER

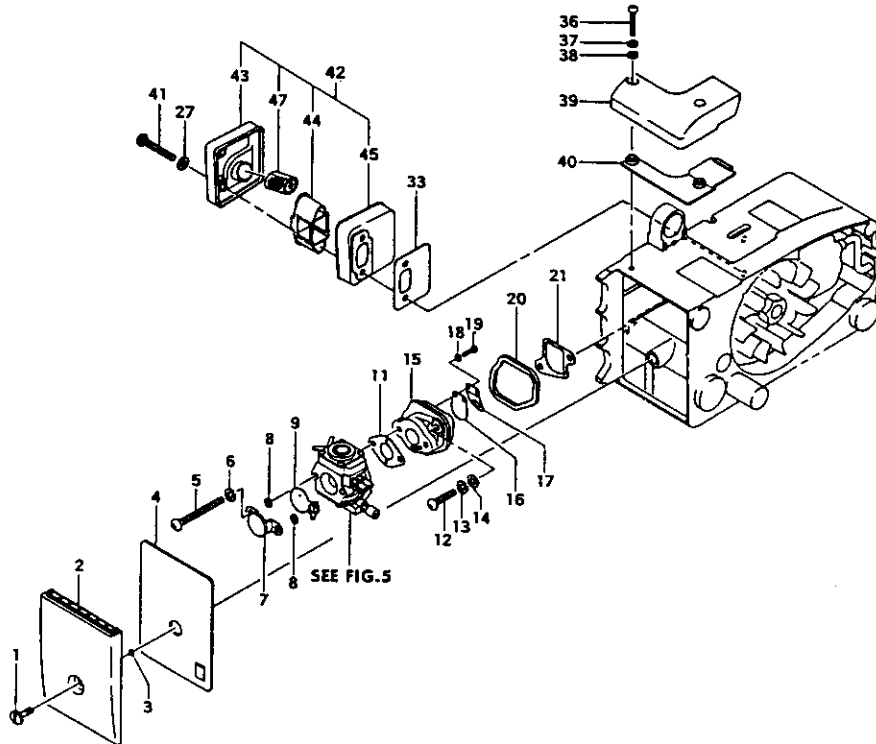

REF. NBR	PART NBR	PART NAME	QTY	SERIAL NBR	REMARKS
2-001	170-32710-200	AIR CLEANER BOLT	1		
2-002	051-32710-200	CLEANER COVER A	1		
2-003	999-67003-000	O-RING P-3	1	-K263120	
2-003	999-67003-003	O-RING P-3	1	K263121-	
2-004	420-01700-800	CLEANER ELEMENT COMP.	1		
2-005	990-11050-401	SCREW 5X40	2		
2-006	992-10050-012	S. WASHER 5	2		
2-007	478-01700-200	BLOW OVER CHECK BOARD	1		
2-008	708-32350-200	CHOKE VALVE SHIM	2		
2-009	700-32710-200	CHOKE VALVE	1		
2-011	402-11850-200	CARBURETOR GASKET	1		
2-012	990-11050-257	SCREW 5X25, STAINLESS	2		
2-013	992-10050-012	S. WASHER 5	2		
2-014	992-00050-011	SMALL WASHER 5	2		
2-015	404-01730-800	CARBURETOR INSULATOR COMP.	1		
2-016	394-01700-200	REED VALVE	1		
2-017	395-01730-200	REED VALVE HOLDER	1		
2-018	992-10030-012	S. WASHER 3	2	D L177107-	
2-019	990-11030-121	SCREW 3X12	2	-L177106	
2-019	990-15030-121	SCREW 3X12	2	H L177107-	
2-020	409-01700-200	CARBURETOR INSULATOR RUBBER	1		
2-021	403-01700-200	INLET MANIFOLD GASKET	1		
2-027	992-01050-011	WASHER 5	2		
2-033	737-01700-200	MUFFLER GASKET	1		
2-036	993-41040-251	HI-LO SCREW 4X25	2		
2-037	992-10040-012	S. WASHER 4	2		
2-038	992-00040-011	SMALL WASHER 4	2		
2-039	152-32710-200	CLEANER COVER B	1		
2-040	153-32710-200	CLEANER COVER C	1		
2-041	990-11050-351	SCREW 5X35	2		
2-042	705-01712-900	MUFFLER ASS'Y	1		
2-043	717-01712-800	MUFFLER BODY B COMP.	1		
2-044	724-01700-200	MUFFLER FITTING METAL	1		
2-045	716-01700-800	MUFFLER BODY A COMP.	1		
2-047	732-01710-200	SPARK ARRESTOR	1		

FIG.3 OIL FILTER & PUMP FILTER

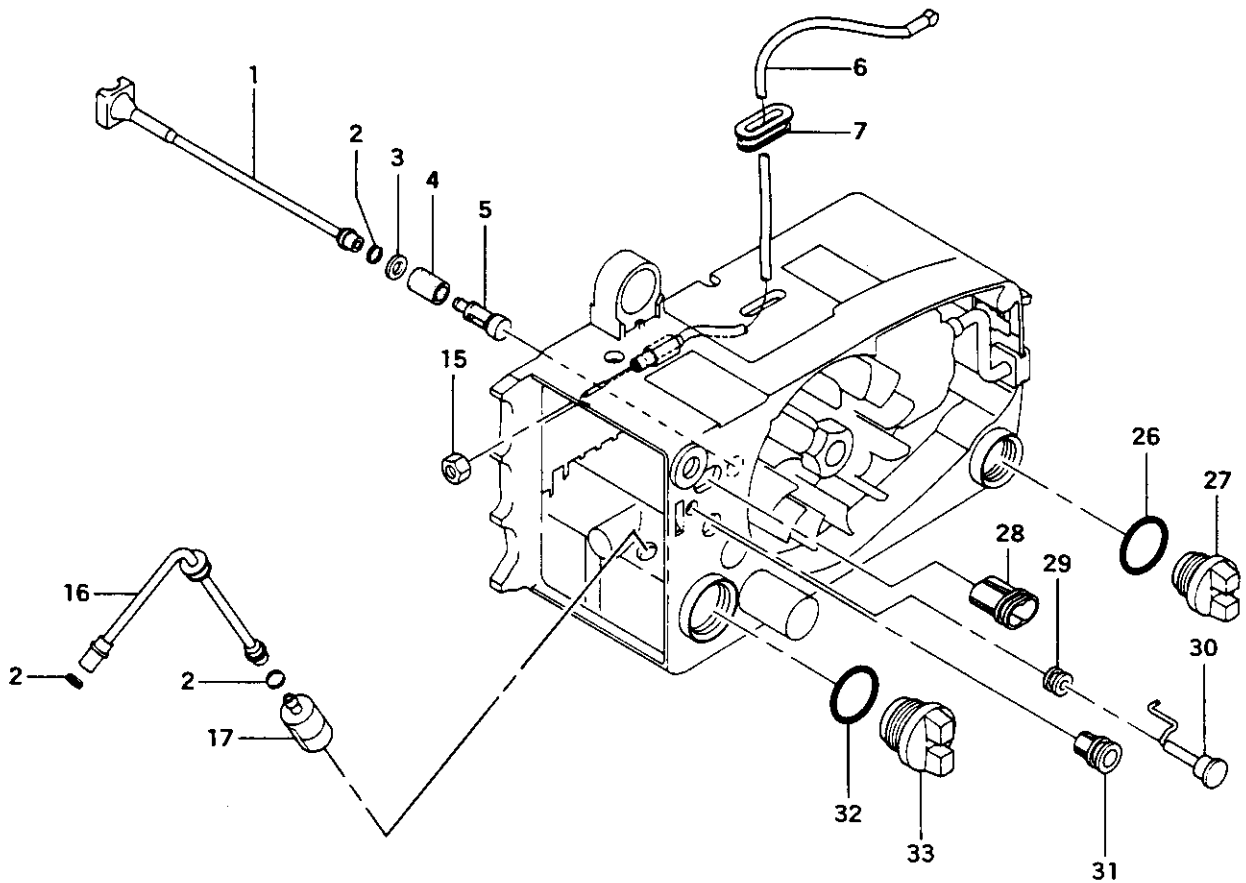

REF. NBR	PART NBR	PART NAME	QTY	SERIAL NBR	REMARKS
3-001	505-32710-200	OIL PIPE B	1		
3-002	680-04019-210	CLIP 7	3		
3-003	992-01050-011	WASHER 5	1		
3-004	487-32712-201	OIL FILTER	1		
3-005	486-32710-200	OIL FILTER BODY	1		
3-006	885-01710-800	THROTTLE WIRE COMP.	1		
3-007	964-01710-200	WIRE GROMMET	1		
3-015	991-01080-013	NUT 6	1		
3-016	678-01700-200	RUBBER PIPE	1		
3-017	675-11800-900	PUMP FILTER BODY ASS'Y	1		
3-026	999-67018-000	O-RING P-18	1		
3-027	520-32710-201	OIL TANK CAP	1		
3-028	190-32710-200	ADJUSTER CAP	1		
3-029	707-32710-200	GROMMET	1		
3-030	704-32710-800	CHOKE BUTTON COMP.	1		
3-031	191-32710-200	GROMMET	1		
3-032	999-67020-000	O-RING P-20	1		
3-033	628-32710-201	FUEL TANK CAP	1		

FIG.4 RECOIL STARTER

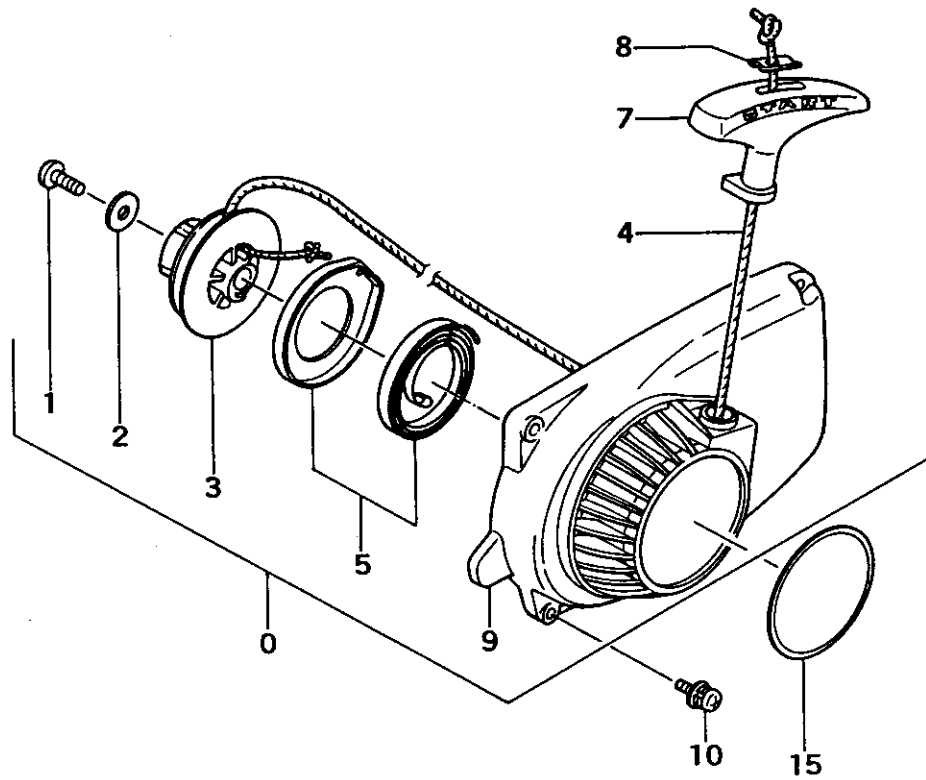

REF. NBR	PART NBR	PART NAME	QTY	SERIAL NBR	REMARKS
4-000	758-01700-901	RECOIL STARTER ASS'Y	1		
4-001	990-15050-121	BINDING HEAD SCREW 5X12	1		
4-002	786-01700-200	RECOIL STARTER WASHER	1		
4-003	774-01700-200	STARTER ROPE REEL	1		
4-004	783-01700-201	STARTER ROPE	1		
4-005	778-01700-901	RECOIL SPRING CASE ASS'Y	1		
4-007	785-04083-200	STARTER HANDLE	1		
4-008	795-04083-200	ROPE STOPPER	1		
4-009	112-01700-801	FAN CASE COMP.	1		
4-010	994-15040-182	SCREW 4X18/PS	4		
4-015	950-32710-200	PROFORCE MARK A	1		

FIG.5 CARBURETOR

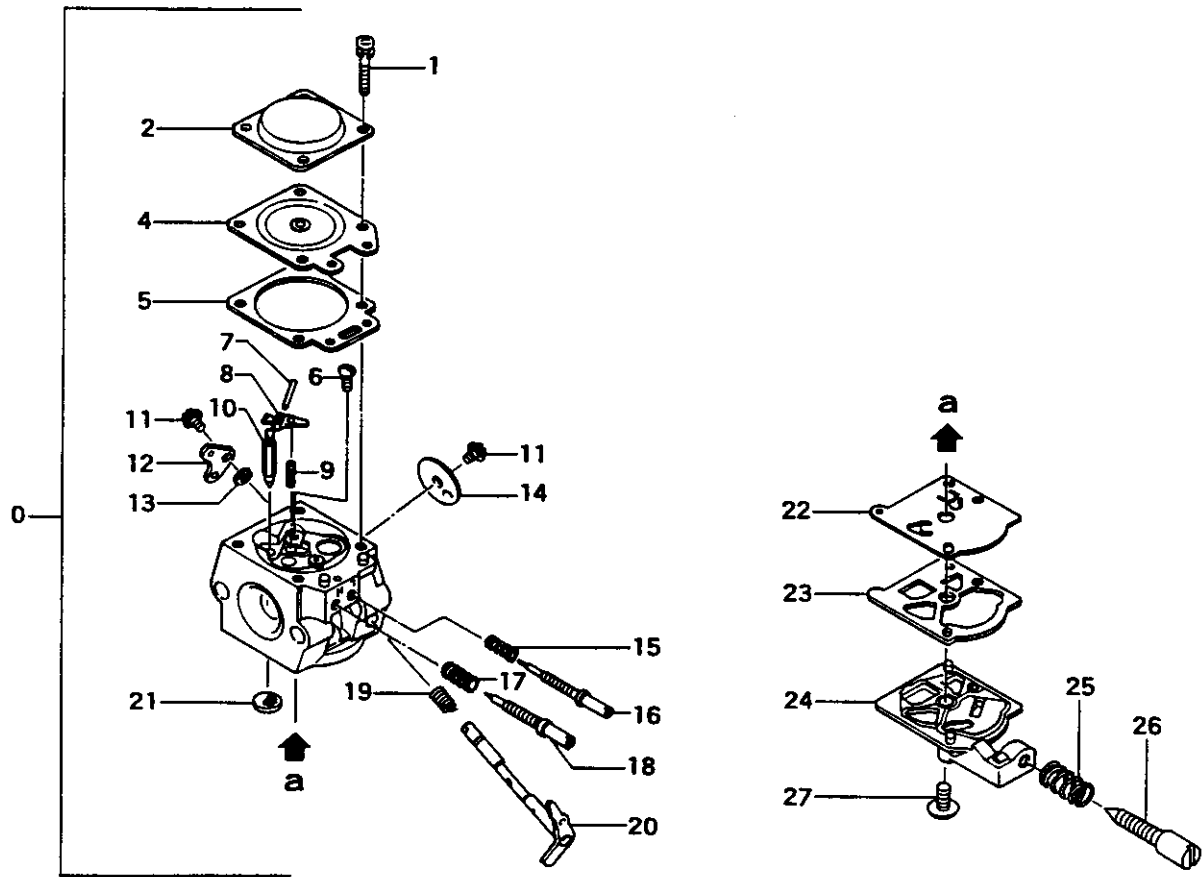

REF. NBR	PART NBR	PART NAME	QTY	SERIAL NBR	REMARKS
5-000	455-25045-900	CARBURETOR ASS'Y	1		
5-001	548-25012-200	SET SCREW	4		
5-002	476-25004-200	DIAPHRAGM COVER	1		
5-004	474-25001-800	METERING DIAPHRAGM COMP.	1		
5-005	475-25001-200	DIAPHRAGM GASKET	1		
5-008	546-25001-200	HINGE PIN SET SCREW	1		
5-007	605-25001-200	HINGE PIN	1		
5-008	473-25001-200	VALVE HINGE	1		
5-009	477-25007-200	VALVE SPRING	1		
5-010	603-25001-200	NEEDLE VALVE	1		
5-011	467-25003-200	SHUTTER SCREW	2		
5-012	491-25027-200	THROTTLE LEVER	1		
5-013	489-25007-200	STOP RING	1		
5-014	488-25001-200	THROTTLE VALVE	1		
5-015	623-25032-200	HIGH/LOW ADJUST SPRING	1		
5-016	461-25027-200	LOW ADJUST SCREW	1		
5-017	485-25040-200	HIGH ADJUST SPRING	1		
5-018	460-25027-200	HIGH ADJUST SCREW	1		
5-019	486-25040-200	THROTTLE SPRING	1		
5-020	464-25016-800	THROTTLE SHAFT COMP.	1		
5-021	578-25007-200	INLET SCREEN	1		
5-022	576-25006-200	PUMP DIAPHRAGM	1		
5-023	577-25007-200	PUMP GASKET	1		
5-024	575-25028-200	PUMP BODY	1		
5-025	463-25006-200	IDLE ADJUST SPRING	1		
5-026	462-25016-200	IDLE ADJUST SCREW	1		
5-027	514-25001-200	SET SCREW	1		

FIG.6 OIL PUMP & SIDE CASE

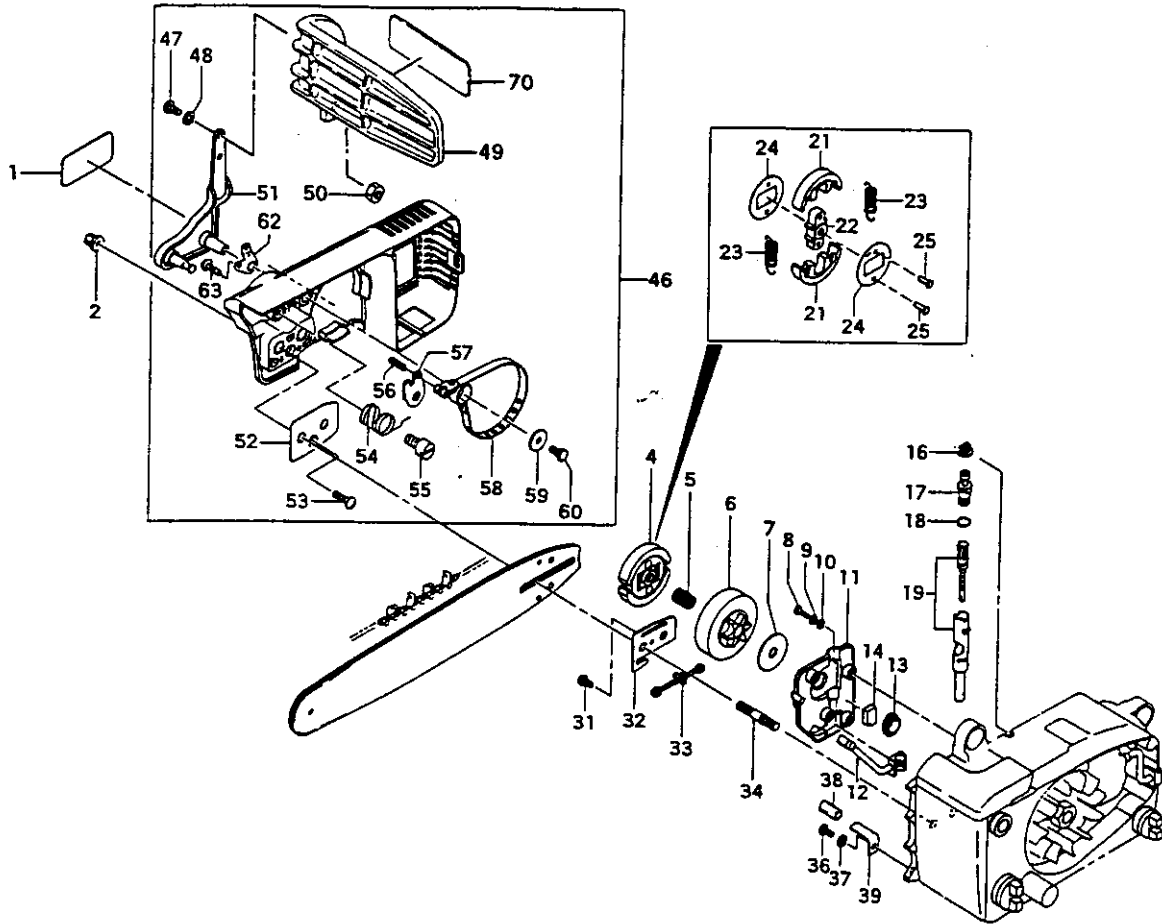

REF. NBR	PART NBR	PART NAME	QTY	SERIAL NBR	REMARKS
6-001	906-32777-200	NAME PLATE	1		
6-002	121-32530-200	CHAIN BAR CLAMP NUT	2		
6-004	287-01700-800	CLUTCH COMP.	1		
6-005	999-62101-301	NEEDLE BEARING 101310	1		
6-006	310-32710-200	CLUTCH HOUSING 3/8"	1		
6-007	358-04050-201	CLUTCH WASHER	1		
6-008	990-11040-121	SCREW 4X12	4		
6-009	992-10040-012	S. WASHER 4	4		
6-010	992-00040-011	SMALL WASHER 4	4	D	-L269580
6-011	097-32710-800	OIL PUMP COVER COMP.	1		
6-012	515-32710-200	OIL PIPE A	1		
6-013	084-32710-201	SCREW GEAR	1		
6-014	567-01700-200	AIR VENT SPONGE	1		
6-016	488-32710-210	OIL ADJUST GROMMET	1		
6-017	501-32710-210	OIL PUMP ADJUSTER	1		
6-018	999-67007-000	O-RING P-7	1		
6-018	999-67006-000	O-RING P-6	1	P	-K108372 K108373-
6-019	088-3277A-91	OIL PUMP CASE SET	1		
6-021	345-01700-200	CLUTCH SHOE	2		
6-022	346-01700-200	CLUTCH BOSS	1		
6-023	342-01700-200	CLUTCH SPRING	2		
6-024	348-01700-200	CLUTCH PLATE A	2		
6-025	992-74004-143	RIVET 4X14	2		
6-031	993-41040-101	SCREW 4X10	1		
6-032	466-32710-200	PLATE	1		
6-033	116-32710-900	TENSION ADJUSTMENT BOLT ASS'Y	1		
6-034	101-32530-200	CHAIN BAR STUD BOLT	2		
6-036	990-11050-121	SCREW 5X12	1		

-To be cont'd-

FIG.6 OIL PUMP & SIDE CASE

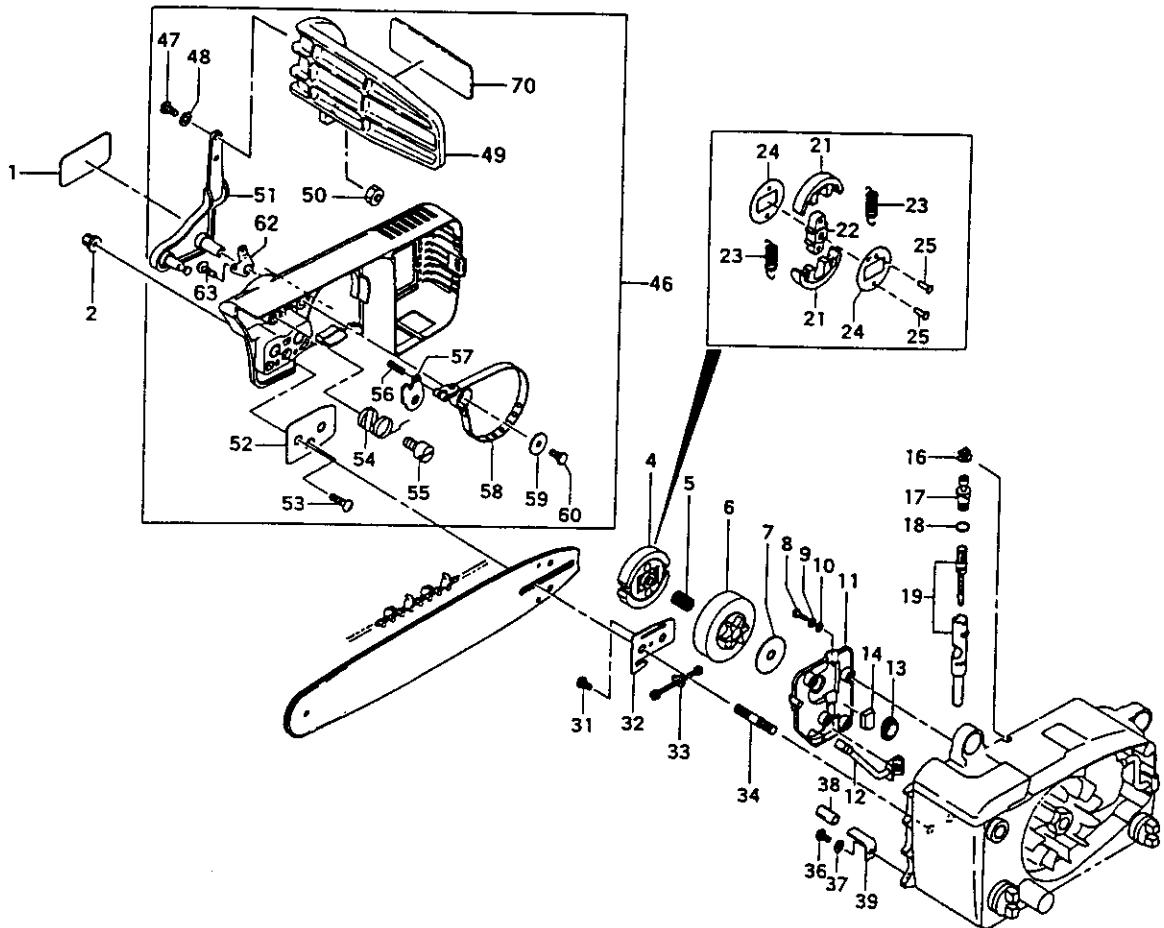

REF. NBR	PART NBR	PART NAME	QTY	SERIAL NBR	REMARKS
6-037	992-10050-012	S.WASHER 5	1		
6-038	700-07105-020	VINYL PIPE	1		
6-039	125-32710-200	CHAIN CATCHER	1		
6-046	040-32750-900	SIDE CASE ASS'Y	1	-K108372	
6-046	040-32750-91	SIDE CASE ASS'Y	1	P K108373-	
6-047	990-11050-181	SCREW 5X18	2		
6-048	992-10050-012	S.WASHER 5	2		
6-049	380-32750-200	BRAKE HANDLE	1		
6-050	991-01050-011	HEX. NUT 5	2		
6-051	361-32750-801	BRAKE LEVER COMP.	1	-K108372	
6-051	361-32750-810	BRAKE LEVER COMP.	1	P K108373-	
6-052	462-32750-200	GUIDE PLATE B	1		
6-053	993-41040-101	SCREW 4X10	1		
6-054	374-32367-210	BRAKE SPRING	1		
6-055	382-32750-200	STEP BOLT A	1		
6-056	993-24040-120	SPRING PIN 4X12	1		
6-057	373-32367-201	BRAKE ARM	1	-K108372	
6-057	373-32771-200	BRAKE ARM	1	N K108373-	
6-058	378-32750-800	BRAKE BELT COMP.	1		
6-059	308-32057-200	BRAKE SHAFT WASHER	1		
6-060	383-32367-210	STEP BOLT B	1		
6-061	040-32750-800	SIDE CASE COMP.	1	-K108372	
6-061	040-32750-810	SIDE CASE COMP.	1	P K108373-	
6-062	359-32771-200	CENTER SPRING	1	N K108373-	
6-063	993-41040-101	SCREW 4X10	1	N K172028-	
6-070	907-32777-200	CAUTION MARK	1	-J200806	
6-070	907-32777-210	CAUTION MARK	1	N J200807-	

FIG.7 HANDLE

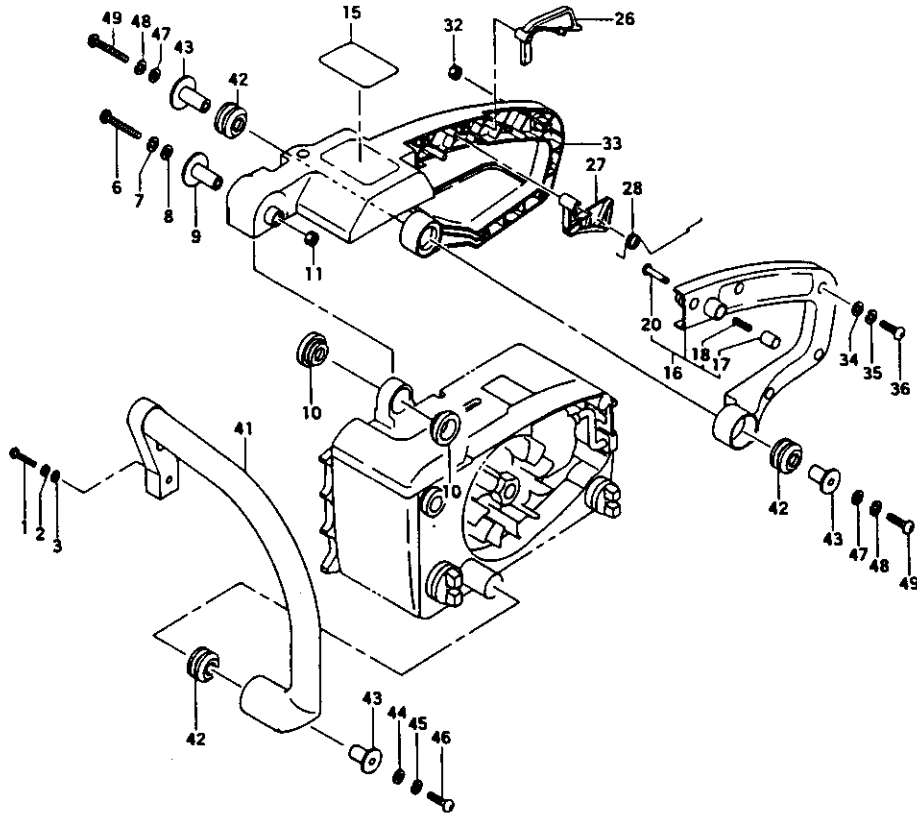

REF. NBR	PART NBR	PART NAME	QTY	SERIAL NBR	REMARKS
7-001	990-11050-251	SCREW 5X25	1		
7-002	992-10050-012	S. WASHER 5	1		
7-003	992-01050-011	WASHER 5	1		
7-006	990-11050-401	SCREW 5X40	1		
7-007	992-10050-012	S. WASHER 5	1		
7-008	992-00050-011	SMALL WASHER 5	1		
7-009	275-32710-201	DAMPER COLLAR A	1		
7-010	219-32750-200	DAMPER A	2		
7-011	991-74050-010	U-NUT 5	1		
7-015	929-32777-200	SYMBOL MARK	1		
7-016	011-32750-801	REAR HANDLE B COMP.	1		
7-017	725-32600-202	PUSH PIN CAP	1		
7-018	066-32300-201	STOPPER SPRING	1		
7-020	064-33225-200	PUSH PIN	1		
7-026	257-32750-201	SAFETY LEVER	1		
7-027	060-32750-202	THROTTLE LEVER	1		
7-028	061-32750-201	THROTTLE LEVER SPRING	1		
7-032	991-01040-011	HEX. NUT 4	5		
7-033	010-32750-802	REAR HANDLE A COMP.	1		
7-034	992-00040-011	SMALL WASHER 4	5		
7-035	992-10040-012	S. WASHER 4	5		
7-036	990-11040-221	SCREW 4X22	5		
7-041	209-32750-800	FRONT HANDLE COMP.	1		
7-042	266-32750-200	DAMPER B	3		
7-043	276-32710-201	DAMPER COLLAR B	3		
7-044	992-00050-011	SMALL WASHER 5	1		
7-045	992-10050-012	S. WASHER 5	1		
7-046	990-11050-301	SCREW 5X30	1		
7-047	992-00050-011	SMALL WASHER 5	2		
7-048	992-10050-012	S. WASHER 5	2		
7-049	990-11050-281	SCREW 5X28	2		

FIG.8 TOOLS & OPTIONAL PARTS

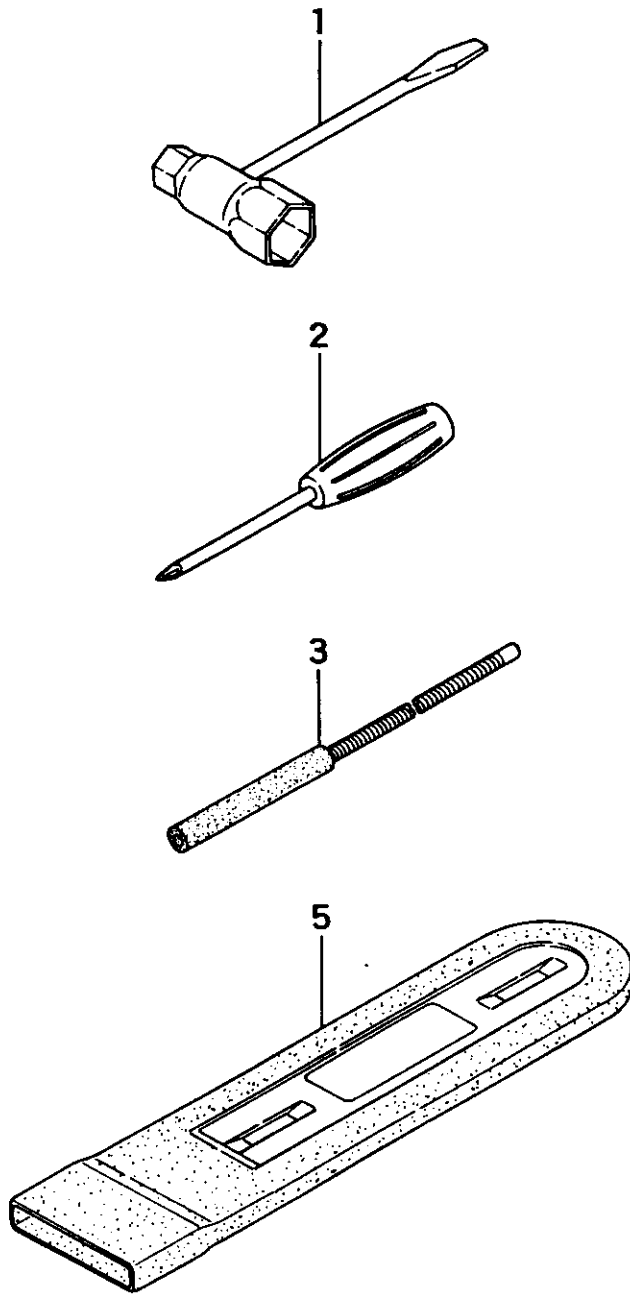

REF. NBR	PART NBR	PART NAME	QTY	SERIAL NBR	REMARKS
8-001	013-29323-501	COMBI. BOX SPANNER 10X19	1		
8-002	862-20000-200	PLUS DRIVER 4	1		
8-003	936-20000-900	FILE ASS'Y 5/32"	1		
8-005	943-32710-201	CHAIN COVER 12"	1		