



DH200RPL Intelligent Air Duct Smoke Detector with Extended Air Speed Range

3825 Ohio Avenue, St. Charles, Illinois 60174
800/736-7672, FAX: 630-377-6495
www.systemsensor.com

Before installing detectors, please thoroughly read the NEMA *Guide for Proper Use of Smoke Detectors in Duct Applications*, which provides detailed information on detector spacing, placement, zoning, wiring, and special applications. Copies of this manual are available from NEMA (National Electrical Manufacturers Association, 2101 L Street NW, Washington, DC 20037). NFPA Standards 72 and 90A should also be referenced for detailed information.

NOTICE: This manual shall be left with the owner/user of this equipment.

IMPORTANT: This detector must be tested and maintained regularly following NFPA 72 requirements. The detector should be cleaned at least once a year.

General Description

An HVAC system supplies conditioned air to virtually every area of a building. Smoke introduced into this air duct system is distributed to the entire building. Smoke detectors designed for use in air duct systems are used to sense the presence of smoke in the duct.

The DH200RPL air duct smoke detector is photoelectric detector. This smoke detection method combines with an efficient housing design that samples air passing through a duct and allows detection of a developing hazardous condition. When sufficient smoke is sensed, an alarm signal is initiated at the fire control panel monitoring the detector, and appropriate action can be taken to shut off fans, blowers and change over air handling systems, etc. This can prevent the distribution or it can isolate toxic smoke and fire gases throughout the areas served by the duct system.

Two LEDs on each detector may illuminate, if programmed by the system control panel, to provide a local alarm indication. There is also a remote alarm output for use with auxiliary devices. The DH200RPL has remote test capability with the RTS451/RTS451KEY Remote Test Station.

The DH200RPL incorporates a cover tamper feature. When the cover is removed for more than 20 minutes, the unit loses communication at the panel, a trouble is indicated at the panel and the alarm relay switches states thereby shutting down fans, dampers and blowers. In the case when the sensor is removed or when there is no power to the unit, only a trouble is indicated at the panel (alarm relay does not work any longer).

Contents of the Duct Smoke Detector Housing Kit

The DH200RPL Duct Smoke Detector consists of the following items (See Figure 1.):

Figure 1. Exploded View Of Duct Smoke Detector Components:

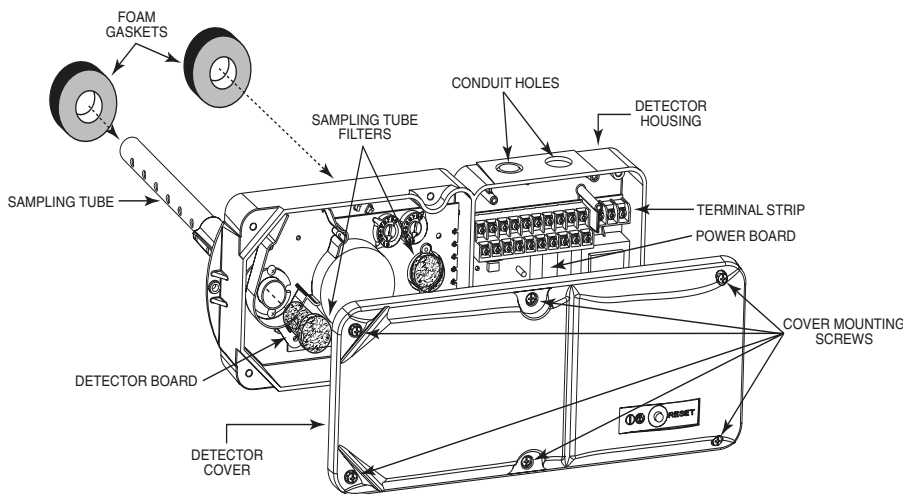

Contents Of The Duct Smoke Detector

1. Complete duct smoke detector assembly with sensor
2. Two #10 x 1/4" sheet metal mounting screws
3. Two sampling tube filters
4. One test magnet
5. Drilling template
6. Two foam gaskets
7. Four #6-self tapping mounting screws for the sampling tube and optional exhaust tube extension
8. One sampling tube end cap
9. One plastic sampling tube
10. One #8 self-tapping screw for plastic sampling tube

NOTE: A detector sensor board **DOES NOT** need to be ordered separately.

NOTE: For ducts over 1 1/2 feet (0.46m), longer sampling tubes must be ordered to complete the installation. They must be the correct length for the width of the duct where they will be installed. See Table 1 on page 3 to determine the sampling tube required for different duct widths.



Limitations of Duct Detectors

The National Fire Protection Association has established that DUCT DETECTORS MUST NOT BE USED AS A SUBSTITUTE FOR OPEN AREA DETECTOR PROTECTION as a means of providing life safety. Nor are they a substitute for early warning in a building's regular fire detection system.

It is strongly recommended that the user read NFPA Standards 90A, 72, and 101.



This device will not operate without electrical power. Fire situations may cause an interruption of power. The system safeguards should be discussed with your local fire protection specialist.



This device will not sense smoke unless the ventilation system is operating.



In order to function properly, this detector must be installed according to the instructions. Do not exceed the electrical or ambient specifications or the detector will not function properly. This detector must be protected from the elements.

Installation Sequence

Step 1.	Verify duct air flow direction and velocity	2
Step 2.	Drill the mounting holes.....	2
Step 2.1	Install the sampling tube for ducts less than 1½ feet (0.46m) wide.....	2
Step 3.	Secure the detector housing to the duct.....	2
Step 4.	Install the sampling tube for ducts greater than 1½ feet (0.46m) wide	2
Step 4.1	Installation for ducts greater than 1½ feet (0.46m) but less than 8 feet (2.4m) wide	3
Step 4.2	Installation for ducts more than 8 feet (2.4m) wide.....	4
Step 5.	Install the filters.....	4
Step 6.	Field wiring	4
Step 7.	Perform detector check.....	5
Step 8.	Install the cover	5
Step 9.	Detector Maintenance and Test Procedures.....	5

[1] Verify Duct Air Flow Direction And Velocity

The DH200RPL duct smoke detector is designed to be used in air handling systems having air velocities of 100 to 4000 feet per minute (0.5 to 20.32m/s). Be sure to check engineering specifications to ensure that the air velocity in the duct falls within these parameters. If necessary, use a velocity meter to check the air velocity in the duct. See Air Flow Test, section 9.1.

[2] Drill The Mounting Holes

Remove the paper backing from the mounting template supplied. Affix the template to the duct at the desired mounting location. Make sure the template lies flat and smooth on the duct. Center punch holes A and B. Drill the holes as indicated on the template.

[2.1] Sampling Tube Installation for Ducts Less Than 1½ Feet (0.46m) Wide (see Figure 2)

1. Remove the front cover.
2. Slide the plastic sampling tube into the housing bushing.
3. Align the holes in the bushing with the holes in the sampling tube. Make sure there are 6 exposed holes on the plastic sampling tube. Secure with the #8 self-tapping screw into the bottom of the permanent tube (shown in Fig. 2).

NOTE: For ducts greater than 1½ feet (0.46m) in width, refer to sections [4], [4.1] and [4.2].

[3] Secure The Detector Housing To The Duct

Slide the foam gaskets over the tube bushings as shown in Figure 3. Use the two 1 ¼" long sheet metal screws to screw the detector housing to the duct.

CAUTION: Do not overtighten the screws.

[4] Sampling Tube Installation for Ducts Greater Than 1½ Feet (0.46m) Wide

The sampling tube is identified by a series of air inlet holes on the tube. A plastic tube is included for ducts up to 1½ feet (0.46m) wide. All other lengths must be purchased separately. Order the correct length, as specified in Table 1, for width of the duct where it will be installed. It is recommended that the sampling tube length extend at least 2/3 across the duct width for optimal performance. The exhaust tube is molded onto the base of the duct housing, and the A2440-00 Exhaust Tube Extension is available as an accessory in those cases where the molded exhaust port does not extend at least 2 inches (50mm) into the duct.

The sampling tube is always installed with the air inlet holes facing into the air flow. To assist proper installation, the tube's mounting flange is marked with an arrow. Make sure the sampling tube is mounted so that the arrow points into the air flow (see Figure 4). Figure 5 shows the various combinations of tube mounting configurations with respect to air flow. Mounting the detector housing in a vertical orientation is acceptable, provided that a metal sampling tube is installed and the air flows directly into the sampling tube holes as indicated in Figure 4.

Figure 2. Plastic sampling tube connected to duct smoke detector:

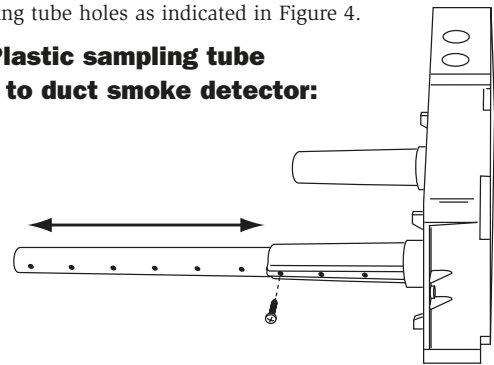

[4.1] Installation For Ducts Greater Than 1½ Feet (0.46m) But Less Than 8 Feet (2.4m) Wide

1. If the tube is longer than the width of the air duct, drill a 3/4" (19mm) hole in the duct opposite the hole already cut for the sampling tube. Make sure the hole is 1" to 2" (25 to 50mm) below the inlet hole on the opposite side of the duct to allow moisture drainage away from the detector. If the tube is shorter than the width of the air duct, install the end cap into the sampling tube as shown in Figure 4. Sampling tubes over 3 ft. (0.91m) long must be supported at the end opposite the duct smoke detector.

- Slide the tube into the housing bushing that meets the air flow first. Position the tube so that the arrow points into the air flow, as shown in Figure 4.
- Secure the tube flange to the housing bushing with two #6 self-tapping screws.
- For tubes longer than the width of the air duct, the tube should extend out of the opposite side of the duct. If there are more than 2 holes in the section of the tube extending out of the duct, select a different length using Table 1. Otherwise, trim the end of the tube protruding through the duct so that 1" to 2" (25 to 50mm) of the tube extend outside the duct. Plug this end with the end cap and tape closed any holes in the protruding section of the tube. Be sure to seal the duct where the tube protrudes.

NOTE: The sampling tube end cap is critical to the proper operation of the duct smoke detectors. The end cap is needed to create the proper air flow to the sensor of the duct smoke detector.

Figure 3. Installation of foam gaskets over sampling tube bushings:

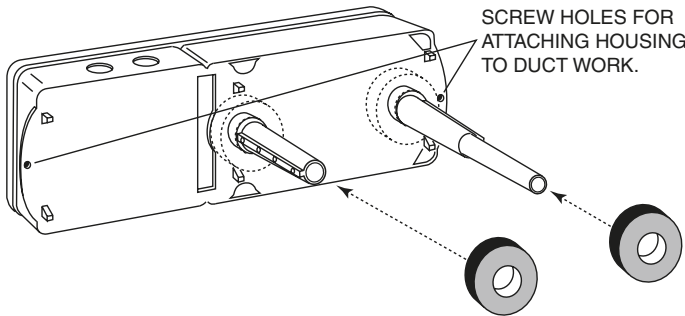

Table 1. Sampling tubes recommended for different duct widths:

Outside Duct Width	Sampling Tube Recommended*
1 to 2 ft. (0.3 to 0.6 m)	ST-1.5
2 to 4 ft. (0.6 to 1.2 m)	ST-3
4 to 8 ft. (1.2 to 2.4 m)	ST-5
8 to 12 ft. (2.4 to 3.7 m)	ST-10

*Must extend a minimum of $\frac{2}{3}$ the duct width

Figure 4. Air duct detector sampling tube:

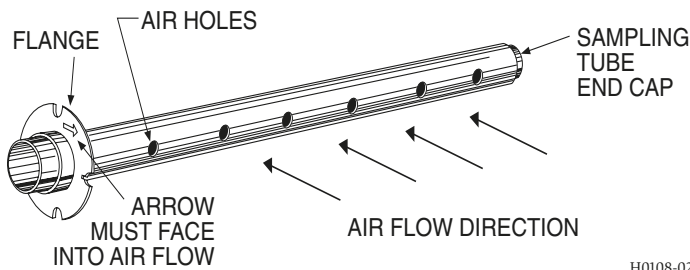
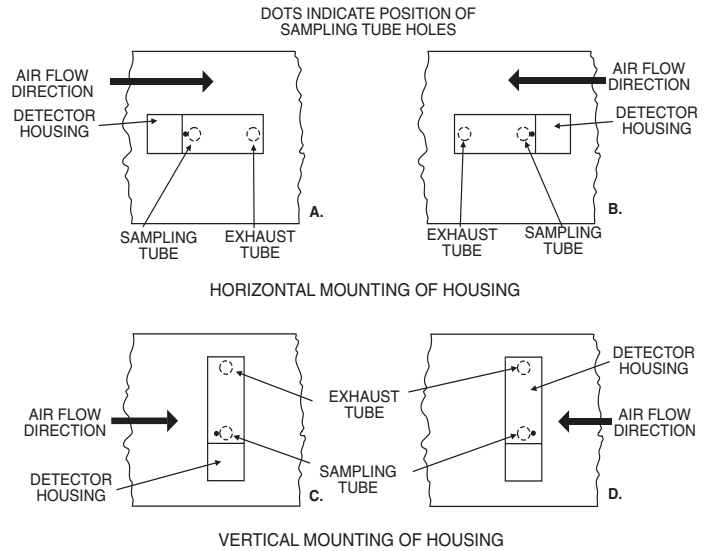

Figure 5. Tube mounting configurations with varying air flow direction:



NOTE: Only metal sampling tubes can be installed in orientations C and D.

[4.2] Installation For Ducts More Than 8 Feet (2.4m) Wide

NOTE: To install sampling tubes in ducts more than 8 feet (2.4m) wide, work must be performed inside the air duct. Sampling of air in ducts wider than 8 feet (2.4m) is accomplished by using the ST-10 sampling tube. If the tube is shorter than the width of the air duct, install the end cap into the sampling tube as shown in Figure 4 and support the end opposite the duct smoke detector.

Install the sampling tube as follows:

- Drill a $\frac{3}{4}$ -inch (19mm) hole in the duct directly opposite the hole already drilled for the sampling tube. Make sure the hole is 1" to 2" (25 to 50mm) below the inlet hole on the opposite side of the duct to allow for moisture drainage.
- Slide the sampling tube with the flange into the housing bushing that meets the air flow first. Position the tube so that the arrow points into the air flow. Secure the tube flange to the housing bushing with two #6 self-tapping screws.
- From inside the duct, couple the other sections of the sampling tube to the section already installed using the $\frac{1}{2}$ -inch conduit fittings supplied. Make sure that the holes on both of the sampling tubes are lined up and facing into the air flow.
- Trim the end of the tube protruding through the duct so that 1" to 2" (25 to 50mm) of the tube extend outside the duct. Plug this end with the end cap and tape closed any holes in the protruding section of the tube. Be sure to seal the duct where the tube protrudes.

NOTE: An alternate method to using the ST-10 is to use two ST-5 sampling tubes. Remove the flange from one of the tubes and install as described above. After the installation, use electrical tape to close off some of the sampling holes so that there are a total of 10 to 12 holes spaced as evenly as possible across the width of the duct.

NOTE: Air currents inside the duct may cause excessive vibration, especially when the longer sampling tubes are used. In these cases a 3 inch (75mm) floor flange (available at most plumbing supply stores) may be used to fasten the sampling tube to the other side of the duct. When using the flange/connector mounting technique, drill a 1-inch to 1¼-inch (25 to 32mm) hole where the flange will be used.

[5] Install The Filters

To install the sampling tube filters, simply push the filters into the sampling and exhaust tube holes, as shown in Figure 6. If a metal sampling tube is used, install the filters into the tube end.



Filters require periodic cleaning or replacement, depending on the amount of dust and dirt accumulated. Visually inspect the filters at least quarterly; inspect them more often if the dust accumulation warrants it. See Section [9.1.2] for more information. Replacement filters can be ordered (filter P/N F36-09-11).

Figure 6. Sampling tube filter installation:

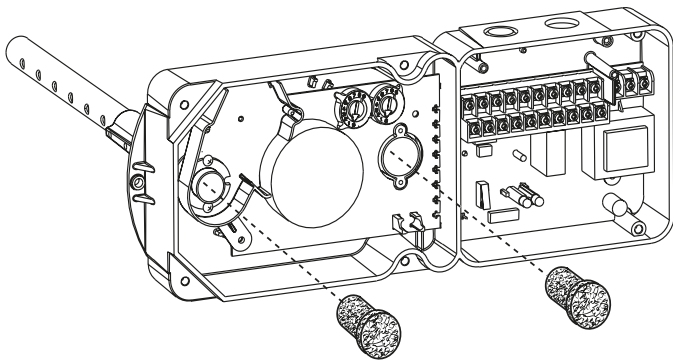

[6] Field Wiring Installation Guidelines

All wiring must be installed in compliance with the National Electrical Code and the local codes having jurisdiction. Proper wire gauges should be used. The conductors used to connect smoke detectors to control panels and accessory devices should be color-coded to prevent wiring mistakes. Improper connections can prevent a system from responding properly in the event of a fire.

For signal wiring, (the wiring between detectors or from detectors to auxiliary devices), it is usually recommended that single conductor wire be no smaller than 18 gauge. The duct smoke detector terminals accommodate wire sizes up to 12 gauge. The last foot (0.3m) of conduit should be flexible conduit (available in electrical supply houses), which facilitates easier installation and puts less strain on the conduit holes in the housing. Solid conduit connections may be used if desired.

Smoke detectors and alarm system control panels have specifications for Signaling-Line Circuit (SLC) wiring. Consult the control panel manufacturer’s specifications for wiring requirements for the particular model control panel being used before wiring the detector loop.

The DH200RPL detector is designed for ease of wiring. The housing provides a terminal strip with clamping plates. Wiring connections are made by stripping about 3⁄8-inch (9mm) of insulation from the end of the wire, sliding the bare end under the plate, and tightening the clamping plate screw.

Two LEDs on each duct smoke detector may light, if programmed by the system LED control panel, to provide a local, visible indication. Remote LED annunciator capability is available as an option. Each duct smoke detector can only be wired to one remote accessory.

Different panel manufacturers offer different feature sets across their different panel models. As a result, certain features of the DH200RPL may be available on some control panels, but not on others. The possible features available in the DH200RPL, if supported by the control panel are:

1. Panel controls the LED operation on sensor. Operational modes are RED blink, RED continuous, and off.
2. The remote output of the RA400Z does not follow the condition of the duct smoke detector LED while in standby. When in alarm, the LED output of the detector and remote will be identical.

Please refer to the operation manual for the UL listed control panel for specific operation of the DH200RPL.

Wiring Instructions

Disconnect power from the communication line before installing the DH200RPL duct smoke detector.

Wire the DH200RPL duct smoke detector per the Control Panel Installation Manual and Figures 9, 10 or 11.

Set the desired address on the sensor board address code wheel switches (see Figure 7).

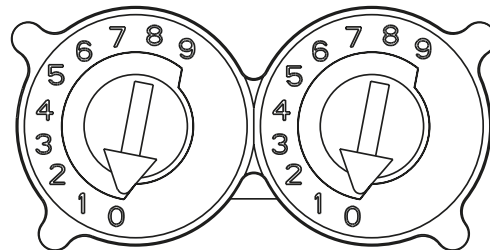

Figure 7. Rotary Address Switches

[7] Perform Detector Check

1. Perform STANDBY AND TROUBLE TEST per Section [9.2.1].
2. Perform MAGNET TEST per Section [9.2.2.1]. The RTS451 test of Section [9.2.2.2] may substitute for this requirement.
3. Perform AIR FLOW TEST per Section [9.1].
4. Perform SMOKE RESPONSE TEST per Section [9.1.1].

[8] Install The Cover

Install the cover using the six screws that are captured in the housing cover. Be certain filters are installed as specified in Section [5]. Make sure that the cover fits into the base groove and that all gaskets are in their proper positions. Tighten the six screws.

[9] Duct Smoke Detector Maintenance and Test Procedures

Test and maintain duct smoke detectors as recommended in NFPA 72. The tests contained in this manual were devised to assist maintenance personnel in verification of proper detector operation.

Before conducting these tests, notify the proper authorities that the smoke detection system will be temporarily out of service. Disable the device or system under test to prevent unwanted alarms.

[9.1] Smoke Entry Tests

[9.1.1] Air Flow

This product is designed to operate over an extended air speed range of 100 to 4000 FPM. To verify sufficient sampling of ducted air, turn the air handler on and use a manometer to measure the differential pressure between the two sampling tubes. The differential pressure should measure at least 0.0015 inches of water and no more than 1.2 inches of water. Because most commercially available manometers cannot accurately measure very low pressure differentials, applications with less than 500 FPM of duct air speed may require one of the following: 1) the use of a current-sourcing pressure transmitter (Dwyer Series 607) per Section 9.1.4 or; 2) the use of aerosol smoke per section 9.1.2.

[9.1.2] Air Flow Test using Aerosol Smoke

This test is intended for low-flow systems (100-500 FPM). If the air speed is greater than 500 FPM, use a conventional manometer to measure differential pressure between the sampling tubes, as described in 9.1.1.

Drill a 1/4" hole 3 feet upstream from the duct smoke detector. With the air handler on, measure the air velocity with an anemometer. Air speed must be at least 100 FPM. Spray aerosol smoke* into the duct through the 1/4" hole for five seconds. Wait two minutes for the duct smoke detector to alarm. If the duct smoke detector alarms, air is flowing through the detector. Remove the duct smoke detector cover and blow out the residual aerosol smoke from the chamber and reset the duct smoke detector. Use duct tape to seal the aerosol smoke entry hole.

*Aerosol smoke can be purchased from Home Safeguard Industries, Malibu, CA. Phone: 310/457-5813.

[9.1.3] Smoke Entry Test

To determine if smoke is capable of entering the sensing chamber, visually identify any obstructions. Plug the exhaust and sampling tube holes to prevent ducted air from carrying smoke away from the detector head, then blow smoke such as cigarette, cotton wick, or punk directly at the head to cause an alarm. REMEMBER TO REMOVE THE PLUGS AFTER THIS TEST, OR THE DETECTOR WILL NOT FUNCTION PROPERLY.

[9.1.4] Air Flow Test using Dwyer Series 607 Differential Pressure Transmitter

Verify the air speed of the duct using an anemometer. Air speed must be at least 100 FPM. Wire the Dwyer transmitter as shown in Figure 8. Connect the leads of the meter to either side of the 1000Ω resistor. Allow unit to warm up for 15 seconds. With both HIGH and LOW pressure ports open to ambient air, measure and record the voltage drop across the 1000Ω resistor (measurement 1), 4.00 volts is typical. Using flexible tubing and rubber stoppers, connect the HIGH side of the transmitter to the sampling tube of the duct smoke detector housing, and the LOW side of the transmitter to the exhaust tube of the duct smoke detector housing. Measure and record the voltage drop across the 1000Ω resistor (measurement 2). Subtract the voltage recorded in measurement 1 from the voltage recorded in measurement 2. If the difference is greater than 0.15 volts, there is enough air flow through the duct smoke detector for proper operation.

Figure 8. Procedure for verifying air flow:

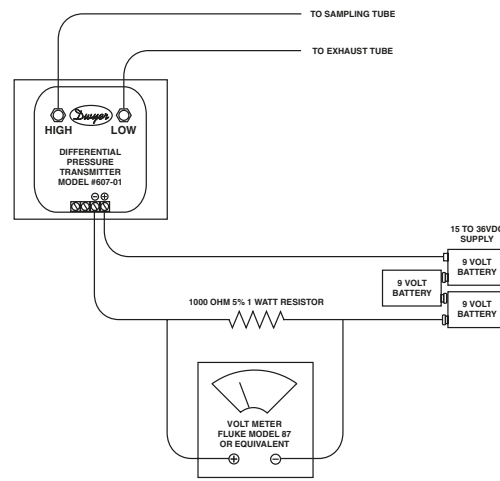

H0163-01

[9.1.5] Filter Replacement

The filters do not substantially affect smoke performance even when up to 90% of the filter is clogged. Quarterly visual inspection usually suffices to determine whether the filters should be replaced because only a high percentage of contamination affects performance. If further testing is required, compare differential pressure readings with and without the filters installed. If the difference exceeds 10% replace the filters. In no case should the pressure differential fall below 0.0015 inches of water.

Figure 9. Wiring Diagram for DH200RPL Duct Smoke Detector using a UL listed control panel:

NOTE: Jumper J1 shunt must be installed for 2-W applications. J1 shunt must be removed for power PCB supervision.

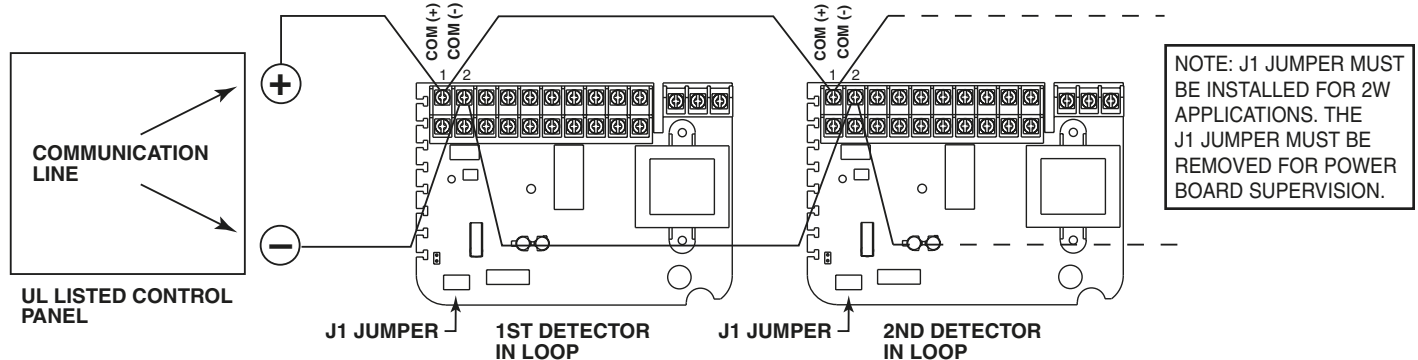

Figure 10. Wiring Diagram for DH200RPL Duct Detector with optional RA400Z:

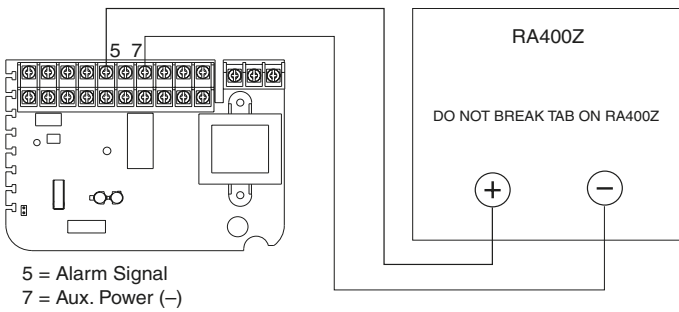

Figure 11. System Wiring Diagram for DH200RPL Duct Smoke Detector with RTS451/RTS451KEY:

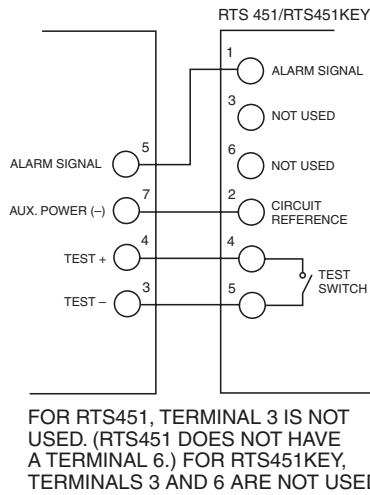
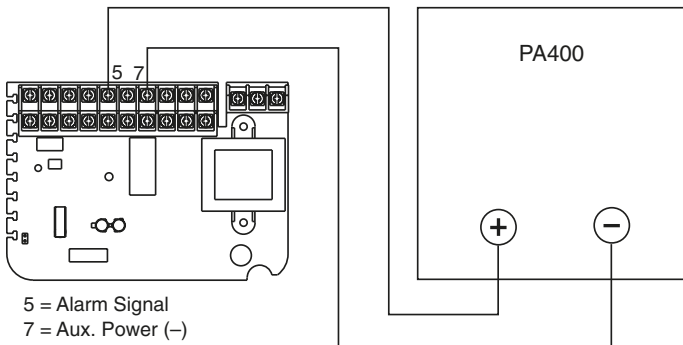

Figure 12. Wiring Diagram for DH200RPL with optional PA400:



[9.2] Standby, Alarm, And Sensitivity Tests

[9.2.1] Standby And Trouble

Standby — If the system control panel is programmed, look for the presence of the flashing LEDs through the transparent housing cover. The LED will flash with each communication.

Trouble — If the detector LEDs do not flash, then the detector lacks power (check wiring, panel programming, or power supply), the detector board is missing (replace), or the unit is defective (return for repair). Additionally, if the cover is removed for more than 20 minutes, the LEDs of the detector will not flash.

Test — The trouble condition can be caused intentionally to verify correct operation of the system. Remove the detector board to cause a trouble condition locally and at the system control panel.

[9.2.2] Alarm Tests

[9.2.2.1] M02-04-00 Magnet Test

1. Place the painted surface of the magnet onto the TEST locator on the bottom of the detector housing (Figure 13).
2. Verify system control panel alarm status and control panel execution of all intended auxiliary functions (i.e. fan shutdown, damper control, etc.)
3. The detector is self-restoring when the magnet is removed. Verify that the system control panel has reset; panel may have to be reset.

Figure 13. Testing detector alarm:

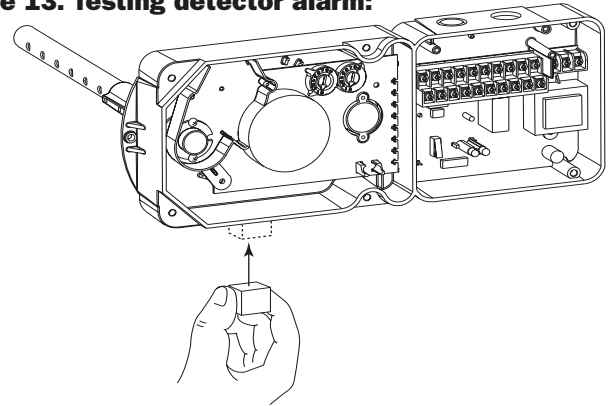
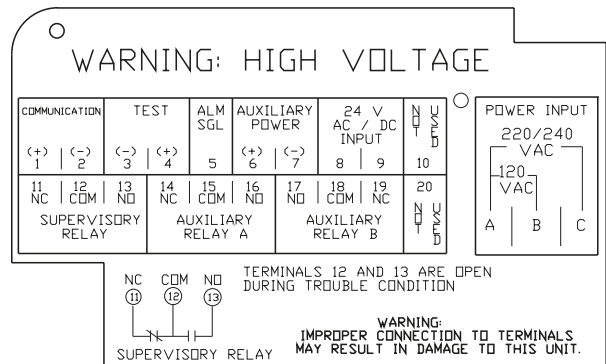

Figure 14. Insulator Card for DH200RPL Duct Smoke Detector:



[9.2.2.2] RTS451/RTS451KEY Remote Station Test

The RTS451/RTS451KEY Remote Test Station facilitates test of the alarm capability of the duct smoke detector. These accessories provide the stimulus to initiate an alarm condition at the detector. The detector is self-restoring when the accessory test stimulus is removed. Verify that the system control panel has reset; panel may need to be reset.

[9.2.3] Sensitivity Tests

Notify the proper authorities that the smoke detector system is undergoing maintenance, and that the system will temporarily be out of service. Disable the device or system undergoing maintenance to prevent unwanted alarms and possible dispatch of the fire department.

[9.3] Maintenance of Duct Smoke Detectors [9.3.1] Air Filters

1. Turn off power to the system.
2. Remove and inspect sampling tube filters.
3. If filters are heavily coated with dirt, replace them with new filters (p/n F36-09-11). If they are not heavily coated, use a vacuum cleaner or compressed air nozzle to remove dust, then reinstall the filters.

[9.3.2] Photo Detector Boards

1. Remove the screen by gently grasping on each side and pulling straight off
2. Lift the photo chamber in the same fashion. Vacuum the screen and cover. Use clean, compressed air to loosen and blow out any remaining debris. Replacement screens (p/n S08-39-01) are available.
3. Vacuum photo chamber, then use clean compressed air to blow area clean.
4. Replace the chamber by pressing it onto the base. Press the screen into place. It should fit tightly on the chamber.

[10] Board Replacement

[10.1] Sensor Board Replacement

1. Remove the two sensor board mounting screws.
2. Pull gently on the board to remove it.
3. To replace the board, align the board mounting features, holes, and the interconnect terminals. Push the board into place.
4. Secure board with the two mounting screws.

[10.2] Power Board Replacement

1. Disconnect wiring from the terminal block.
2. Remove the two power board mounting screws.
3. Pull gently on the board to remove it.
4. To replace the board, align the board mounting features, holes, and the interconnect terminals. Push the board into place.
5. Secure board with the two mounting screws.
6. Re-connect wiring to terminal block.

[11] Model DH200RPL Air Duct Smoke Detector Specifications

Operating Temperature Range 32° to 131°F (0° to 55°C)

Storage Temperature Range -22° to 158°F (-30° to 70°C)

Humidity Range 10% to 93% (non-condensing)

Air Velocity 100 to 4000 ft/min (0.5 to 20.32 m/sec.)

Dimensions 14³/₈" L x 5¹/₂" W x 2³/₄" D (37 cm L x 14 cm W x 7 cm D)

Current Requirements (using no accessories)

Power supply voltage:	20-30 VDC	24 VAC, 50-60 Hz	120 VAC, 50-60Hz	220/240 VAC, 50-60Hz
Max. standby current:	26 mA	65 mA RMS	44 mA RMS	25 mA RMS
Max. alarm current:	87 mA	182 mA RMS	52 mA RMS	30 mA RMS
Alarm response time:	3 to 10 Sec.	3 to 10 Sec.	3 to 10 Sec.	3 to 10 Sec.
Power up time:	2 Sec.	2 Sec.	2 Sec.	2 Sec.

Contact Ratings

Alarm auxiliary contacts* (DPDT)	10 A @ 30 VDC 10 A @ 277 VAC (.75 power factor) 240 VA @ 249 VAC (0.4 power factor) 1/8 HP @ 120 VAC 1/4 HP @ 240 VAC
Supervisory contact (SPST)	2.0 A @ 30 VDC (resistive)

*Minimum switching current for auxiliary contact must be 100 mA DC minimum @ 5 VDC.

Accessory Current Loads at 24 VDC

Device	Standby	Alarm
PA400	0 mA	15 mA Max.
RA400Z	0 mA	12 mA Max.
RTS451/RTS451KEY	0 mA	10 mA Max.

Programming Specifications/Requirements for Intelligent System

Control Panels

There are a limited number of devices that can have their LEDs programmed to illuminate. The actual number of devices is determined by the control panel and its ability to supply LED current. Refer to the Control Panel Installation Manual for details.

Accessories	Part No.	Accessories	Part No.
Remote LED	RA400Z	Replacement Photo Insect Screen	S08-39-01
Magnetic Remote Test	RTS451	Replacement End Cap for Plastic Sampling Tube	P48-61-00
Key-Activated Remote Test	RTS451KEY	Replacement End Cap for Metal Sampling Tubes	P48-21-00
Replacement Filters	F36-09-11	Replacement Photoelectric Sensor Board	A5053
Replacement Test Magnet	M02-04-00	Replacement Power Board (w/relay)	A5060

Please refer to insert for the Limitations of Fire Alarm Systems

Three-Year Limited Warranty

System Sensor warrants its enclosed air duct smoke detector to be free from defects in materials and workmanship under normal use and service for a period of three years from date of manufacture. System Sensor makes no other express warranty for this air duct smoke detector. No agent, representative, dealer, or employee of the Company has the authority to increase or alter the obligations or limitations of this Warranty. The Company's obligation of this Warranty shall be limited to the repair or replacement of any part of the air duct smoke detector which is found to be defective in materials or workmanship under normal use and service during the three year period commencing with the date of manufacture. After phoning System Sensor's toll free number 800-SENSOR2 (736-7672) for a Return Authorization number, send defective units postage prepaid to: System Sensor, Returns Department, RA # _____, 3825 Ohio Avenue, St. Charles, IL 60174. Please include a note describing the malfunction and suspected cause of failure. The Company shall not be obligated to repair or replace units which are found to be defective because of damage, unreasonable use, modifications, or alterations occurring after the date of manufacture.

In no case shall the Company be liable for any consequential or incidental damages for breach of this or any other Warranty, expressed or implied whatsoever, even if the loss or damage is caused by the Company's negligence or fault. Some states do not allow the exclusion or limitation of incidental or consequential damages, so the above limitation or exclusion may not apply to you. This Warranty gives you specific legal rights, and you may also have other rights which vary from state to state. To keep your equipment in excellent working order, ongoing maintenance is required per the manufacturer's recommendations and UL and NFPA standards. At a minimum, the requirements of Chapter 7 of NFPA 72, the National Fire Alarm Code, shall be followed. A preventative maintenance agreement should be arranged through the local manufacturer's representative. Though smoke detectors are designed for long life, they may fail at any time. Any smoke detector, fire alarm equipment, or any component of that system which fails shall be repaired or replaced as soon as possible.

FCC Statement

This device complies with part 15 of the FCC Rules. Operation is subject to the following two conditions: (1) This device may not cause harmful interference, and (2) this device must accept any interference received, including interference that may cause undesired operation.

Note: This equipment has been tested and found to comply with the limits for a Class B digital device, pursuant to Part 15 of the FCC Rules. These limits are designed to provide reasonable protection against harmful interference in a residential installation. This equipment generates, uses and can radiate radio frequency energy and, if not installed and used in accordance with the instructions, may cause harmful interference to radio communications. However, there is no guarantee that interference will not occur in a particular installation. If this equipment does cause harmful interference to radio or television reception, which can be determined by turning the equipment off and on, the user is encouraged to try to correct the interference by one or more of the following measures:

- Reorient or relocate the receiving antenna.
- Increase the separation between the equipment and receiver.
- Connect the equipment into an outlet on a circuit different from that to which the receiver is connected.
- Consult the dealer or an experienced radio/TV technician for help.