

2100AT Photoelectronic Smoke Detector with Fixed Heat and Integral Temp-3 Sounder

Figure 1. Wiring diagram for the 2100AT detector:

IMPORTANT: OBSERVE POLARITY
Polarity must be observed on the power and remote annunciator connections.

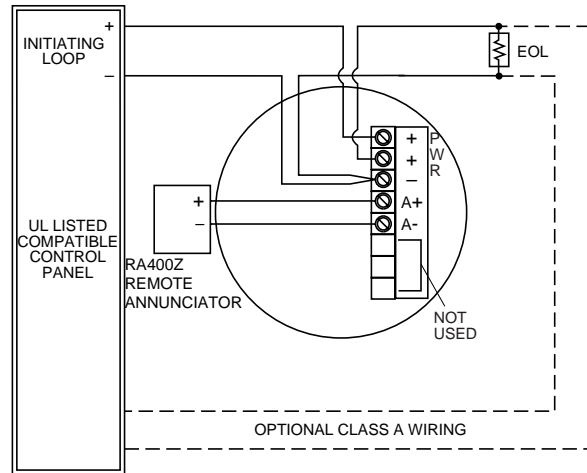

NOTE: Only one detector per zone shall be used, unless when in alarm the panel switches the zone to a reverse polarity, noncurrent-limited power supply. The 2100AT detector shall not be mixed with other 2-wire detector types on the same zone.

A78-2336-15

Specifications

Diameter:	5.5 inches (140 mm)
Height (including mounting bracket):	2.05 inches (52 mm)
Weight:	7.5 oz. (210 g)
Operating Temperature Range	32° to 100° F (0° to 38° C)
Operating Humidity Range:	10% to 93% Relative Humidity, Noncondensing
Latching Alarm:	Reset by momentary power interruption
Audible Signal:	85 dBA minimum when in alarm or with supply polarity reversed
Heat Sensor:	135° F Fixed Temperature Electronic Thermistor

Electrical Ratings

System Voltage (nominal):	12 or 24 VDC
Minimum:	8.5 VDC
Maximum:	35 VDC
Maximum Ripple Voltage:	30% of nom. Voltage (peak to peak)
Standby Current:	50 μ A average, 100 μ A maximum
Alarm Ratings:	29 mA typical at 12 VDC, 63 mA typical at 24 VDC, 100 mA maximum (If used, the RA400Z Remote Annunciator operates within the specified detector alarm currents.)

Reset Voltage:	1.8 VDC minimum
Reset Time:	0.6 seconds maximum
Start-up Time:	30 seconds maximum (after 60 sec. reset)
EOL Relay:	A77-716B, 12/24 VDC
Special Considerations:	

NOTE: Only one detector per zone shall be used, unless when in alarm the panel switches the zone to a reverse polarity, non-current limited power supply. For panels that do not provide this feature, a reversing relay, such as System Sensor's RR-2, may be used. When utilized with the 2100AT, it allows for more than one detector to be utilized on a loop. Some panels may require the use of programmable outputs. Refer to System Sensor literature for further information on the RR-2. The 2100AT detector shall not be mixed with other 2-wire detectors on the same zone.

-Due to the built-in temporal pattern, use this detector only with a non-coded power source.

Figure 2. Surface mounting of 2100AT smoke detector on 3¹/₂-inch and 4-inch octagonal box:

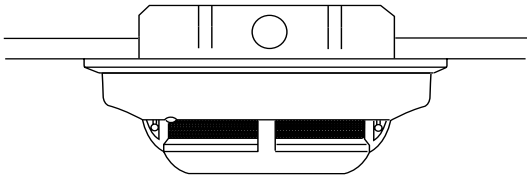

A78-2563-03

Before Installing

Please thoroughly read the System Sensor manual I56-407, *Guide for Proper Use of System Smoke Detectors*, which provides detailed information on detector spacing, placement, zoning, wiring, and special applications. Copies of this manual are available at no charge from System Sensor.

NOTICE: This manual shall be left with the owner/user of this equipment.

IMPORTANT: This detector must be tested and maintained following NFPA 72 requirements. The detector should be cleaned at least once a year.

General Description

Model 2100AT is a 2-wire photoelectronic smoke detectors that uses a state-of-the-art optical sensing chamber. This detector also provides restorable, 135°F fixed-temperature heat detection. The 2100AT heat-detection unit is integrated with the photoelectronic sensor. This detector is designed to provide open area protection and to be used with compatible UL-listed panels only.

In addition, a piezoelectric horn in each detector produces an interrupted, 85 dBA tone when the individual detector alarms or when the supply voltage polarity is reversed.

Installation of this detector is simplified by the use of a mounting bracket and a plug-in screw terminal block that can be prewired to the system, allowing the detector to be easily installed or removed for cleaning. The detector’s sensitivity can be tested in place using the MOD400R Test Module.

An LED on the detector provides a local visual indication of

the detector’s status. If power is applied to the detector and it is functioning normally in standby within the listed sensitivity range, the status LED blinks every ten seconds. The LED also latches on in alarm. If the LED stops blinking, the unit should be removed for maintenance and inspection.

The detectors also include an output that allows optional connection of the RA400Z Remote Annunciator.

Mounting

Each 2100AT detector is supplied with a mounting bracket that permits the detector to be mounted:

1. To a single gang box, or
2. Directly to a 3-1/2 inch or 4 inch octagonal box, or
3. To a 4 inch square electrical box by using a plaster ring.
4. Directly to the ceiling using drywall anchors, if permitted by local codes and/or the authority having jurisdiction.

Tamper-resistant Feature

This detector includes a tamper-resistant feature that prevents its removal from the bracket without the use of a tool. To make the detector tamper-resistant, remove the smaller tab by breaking it at the scribed line on the tamper resistant tab on the detector mounting bracket (see Figure 3), then install the detector. To remove the detector from the bracket once it has been made tamper resistant, use a small screwdriver to depress the tamper-resistant tab, located in the slot on the mounting bracket, and turn the detector counterclockwise.

Wiring Installation Guidelines

All wiring must be installed in compliance with the National Electrical Code, applicable local codes, and any special requirements of the local authority having jurisdiction. Proper wire gauges should be used. The conductors used to connect smoke detectors to control panels and accessory devices should be color-coded to reduce the likelihood of wiring errors. Improper connections can prevent a system from responding properly in the event of a fire.

The screw terminal block accepts 14 – 22 gauge wire. For best system performance, all wiring should be installed in separate grounded conduit. Do not mix fire system wiring in the same conduit as any other electrical wiring. Twisted used before wiring the detector loops.

Figure 3. 2100AT smoke detector mounting bracket:

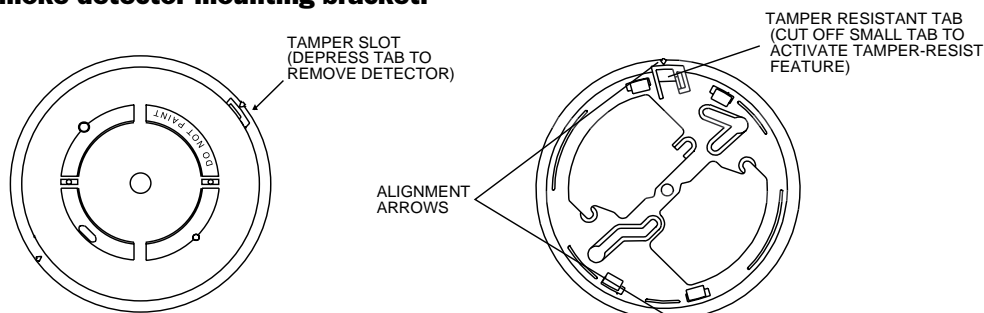

A78-2333-06

System Sensor smoke detectors are marked with a compatible identifier located as the last digit of a five digit code stamped on the back of the product. Connect detectors only to compatible control units as indicated in System Sensor's compatibility chart which contains a current list of UL-listed compatible control units and detectors. A copy of this list is available from System Sensor upon request.

Wire connections are made by stripping about 1/4 inch of insulation from the end of the feed wire, inserting the wire into the appropriate terminal, and tightening the screw to secure the wire in place.

Installation



Remove power from the control unit or initiating device circuits before installing detectors.

1. Wire the plug-in screw terminal block per Figure 1 and plug the terminal block into the detector.
2. Align the arrows on the detector with the arrows on the mounting bracket.
3. Turn the detector clockwise in the mounting bracket until it clicks into place.
4. After all detectors have been installed, apply power to the control unit or initiating device circuits.
5. Test the detector as described in **TESTING**.
6. Reset the detector at the system control panel.
7. Notify the proper authorities the system is in operation.



Dust covers are an effective way to limit the entry of dust into smoke detector sensing chambers. However, they may not completely prevent airborne dust particles from entering the detector. Therefore, System Sensor recommends the removal of detectors before beginning construction or other dust producing activity. Be sure to remove dust covers from any sensors that were left in place during construction as part of returning the system to service.

Figure 4. Top and side views of test switch position:

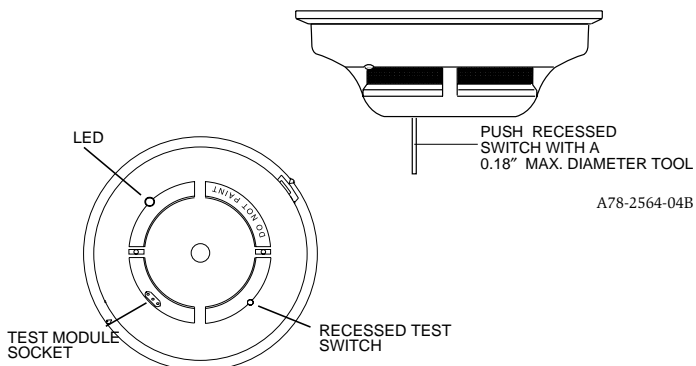

A78-2564-04A

Testing

NOTE: Before testing, notify the proper authorities that the smoke detector system is undergoing maintenance and will be temporarily out of service. Disable the zone or system undergoing maintenance to prevent unwanted alarms.

Detectors must be tested after installation and following periodic maintenance. Test the 2100AT as follows:

A. Test Switch

1. A recessed test switch is located on the detector housing (See Figure 4).
2. Press and hold the recessed test switch with a 0.18 inch maximum diameter tool such as an allen wrench or small screwdriver.
3. The detector's LED should light within 5 seconds.

B. Test Module (System Sensor Model No. MOD400R).

The MOD400R test module can be used with a DMM or analog voltmeter to check the detector sensitivity as described in the test module's manual.

C. Smoke Entry Test

Hold a smoldering punk stick or cotton wick at the side of the detector and gently blow smoke through the detector until the unit alarms.

D. Direct Heat Method (Hair dryer of 1000-1500 watts)

Direct the heat toward either of the side thermistors. Hold the heat source about 12 inches from the detector in order to avoid damage to the plastic. The detector will reset only after it has had sufficient time to cool and the power source has been momentarily interrupted.

Both smoke and heat detection testing are recommended for verifying system protection capability.

A detector that fails to activate with any of the above tests should first be cleaned as outlined in **MAINTENANCE**. If the detector still fails to activate, return it for repair.

Notify the proper authorities the system is back in operation.

Maintenance

NOTE: Before removing the detector, notify the proper authorities that the smoke detector system is undergoing maintenance and will be temporarily out of service. Disable the zone or system undergoing maintenance to prevent unwanted alarms.

NOTE: Before removing the detector cover, note the position of the thermistors. Make sure the thermistors are not bent over when the housing is replaced.

1. Remove the detector housing by gently prying the four housing tabs on the bottom of the base with a small-bladed screwdriver and pull the housing from the base. Use caution to avoid damaging the thermistors.
2. Vacuum the screen carefully without removing it.
3. Remove screen assembly, pulling straight out (see Figure 5).
4. Remove the sensing chamber cover.
5. Clean the sensing chamber by vacuuming or blowing out dust and particles.
6. Replace the sensing chamber cover, aligning the arrow on the cover top with the arrow on the printed circuit board.
7. Replace the screen by placing the screen assembly over the sensing chamber cover and twisting until it snaps into place.
8. Replace the housing by aligning the three triangular slots on the base with their counterparts on the housing. Gently press the housing until it locks in place. Check to make sure that the thermistors are in the upright position.

9. Reinstall the detector.
10. Notify the proper authorities that the system is back in operation.

Figure 5. Removal of cover and screen for cleaning:

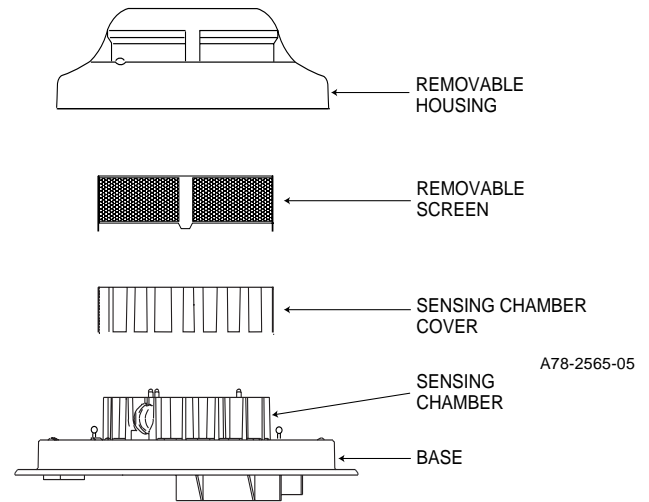

Please refer to insert for the Limitations of Fire Alarm Systems

Three-Year Limited Warranty

System Sensor warrants its enclosed smoke detector to be free from defects in materials and workmanship under normal use and service for a period of three years from date of manufacture. System Sensor makes no other express warranty for this smoke detector. No agent, representative, dealer, or employee of the Company has the authority to increase or alter the obligations or limitations of this Warranty. The Company's obligation of this Warranty shall be limited to the repair or replacement of any part of the smoke detector which is found to be defective in materials or workmanship under normal use and service during the three year period commencing with the date of manufacture. After phoning System Sensor's toll free number 800-SENSOR2 (736-7672) for a Return Authorization number, send defective units postage prepaid to: System Sensor, Repair Depart-

ment, RA # _____, 3825 Ohio Avenue, St. Charles, IL 60174. Please include a note describing the malfunction and suspected cause of failure. The Company shall not be obligated to repair or replace units which are found to be defective because of damage, unreasonable use, modifications, or alterations occurring after the date of manufacture. In no case shall the Company be liable for any consequential or incidental damages for breach of this or any other Warranty, expressed or implied whatsoever, even if the loss or damage is caused by the Company's negligence or fault. Some states do not allow the exclusion or limitation of incidental or consequential damages, so the above limitation or exclusion may not apply to you. This Warranty gives you specific legal rights, and you may also have other rights which vary from state to state.