

**HARRINGTON**  
HOISTS AND CRANES



ELECTRIC  
**POWERED**  
HOISTS

## Working Harder For You

In 1876, Edwin Harrington dramatically improved the self-sustaining hoist by introducing the worm-gear design. Since then, the company he founded has earned a proud reputation for product innovations and consistent quality that our customers count on to meet their diverse requirements.

Over the years we have developed and grown by recognizing the value of our customers and responding to your needs. The daily mission of our organization is to provide you, the customer, with the highest quality in our products, service and support.

In addition to our superior products and expanded facilities, we offer a Sales and Customer Service team that is dedicated to serving you, a well qualified Engineering Department to support your technical needs and a full support staff who all know the importance of working together to provide solutions for your material handling projects.

We are working harder to be the supplier-of-choice for all of your hoist and crane applications.

## Table of Contents

<b>NER/ER Electric Chain Hoists</b>	
Features and Benefits . . . . .	4
<b>MR Motorized Trolleys</b>	
Features and Benefits . . . . .	6
<b>NER/ER Electric Chain Hoists With Hook and Lug Suspensions</b>	
Standard Specifications and Dimensions . . . . .	8
<b>NERM/ERM Electric Chain Hoists With Motorized Trolleys</b>	
Standard Specifications and Dimensions . . . . .	12
<b>NERP/ERP and NERG/ERG Electric Chain Hoists With Push and Geared Trolleys</b>	
Standard Specifications and Dimensions . . . . .	18
<b>NER/ER Cylinder Control Electric Chain Hoists With Hook and Lug Suspensions</b>	
Features and Benefits . . . . .	24
Standard Specifications and Dimensions . . . . .	24
<b>ER Large Capacity Electric Chain Hoists With Hook and Lug Suspensions</b>	
Standard Specifications and Dimensions . . . . .	26
<b>ERM Large Capacity Electric Chain Hoists With Motorized Trolleys</b>	
Standard Specifications and Dimensions . . . . .	28
<b>ERP and ERG Large Capacity Electric Chain Hoists With Push and Geared Trolleys</b>	
Standard Specifications and Dimensions . . . . .	32
<b>SNER Electric Chain Hoists With Hook and Lug Suspensions and Motorized, Push and Geared Trolleys</b>	
Features and Benefits . . . . .	36
Standard Specifications and Dimensions . . . . .	36
<b>ED Electric Chain Hoists With Hook Suspension and Mini Trolley</b>	
Features and Benefits . . . . .	42
Standard Specifications and Dimensions . . . . .	42
ET Mini Trolley . . . . .	45
<b>Options and Technical Data . . . . .</b>	<b>46</b>
<b>Product Code for NER/ER Series . . . . .</b>	<b>49</b>
<b>Complete Product Offering . . . . .</b>	<b>51</b>

## NER/ER Electric Chain Hoists

### Extreme Duty Motor

Increased performance through 60 minute duty rating, H4 classification, Class B insulation, cooling fins, and standard thermal motor protection. Offers higher horsepower than most competitors.

### External Motor Fan

Functions to quickly eliminate motor and brake heat. This results in improved hoist duty rating and greatly lengthens brake life. Motor is totally enclosed, fan cooled (TEFC).

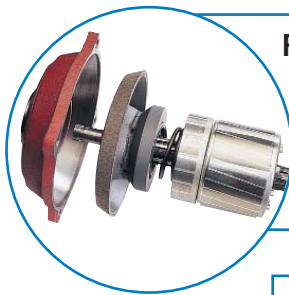

### Pull-Rotor Motor Brake

Extremely durable and reliable, this advanced design contains no brake coil to fail like conventional disc brakes.

### Compact Aluminum Body

Die-cast body is lightweight and offers low headroom—one of the best in the industry. Paint is electrostatically applied.

### Durable Push-Button Pendant

Easy to use, one-handed operation. Rated IP65. Standard control voltage is 110V. Strain relief wire is molded to pendant cord for added support and dependability.



### Forged Carbon Steel Hooks

Under excessive loads will open gradually and not fracture. Ball bearings produce smooth rotation. Bottom hook will swivel 360 degrees. Heavy-duty hook latches are standard.



### Unique Chain Guide

Provides quiet and smooth guiding of chain. Easily replaced without disassembly of hoist. Heavy cast iron construction for improved wear versus stamped steel design offered by many manufacturers.

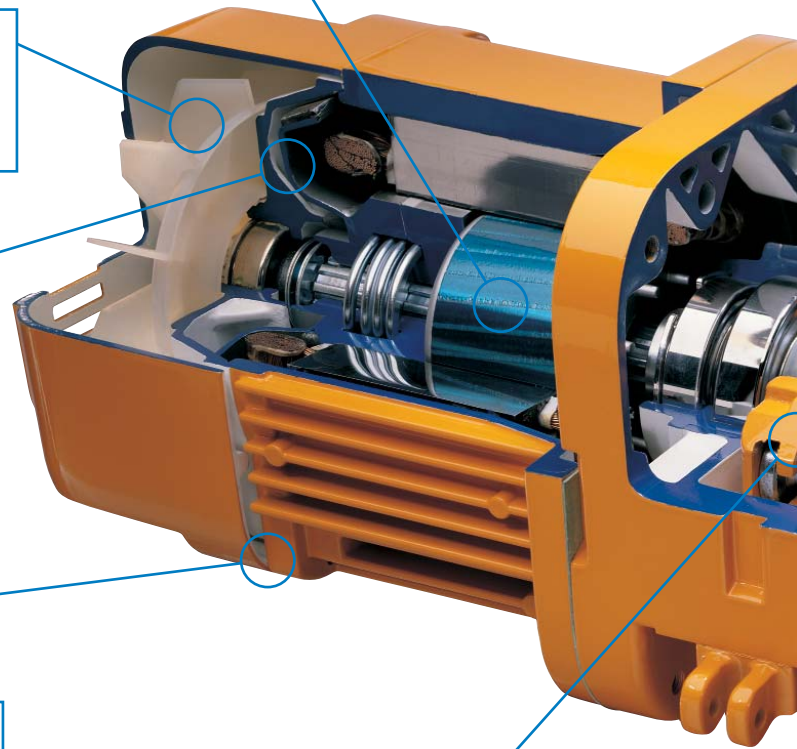

**Load Sheave**

Deep-groove pockets fully support the load chain during operation. Reduces vibration and chain wear and provides a true vertical lift.

**Long Life Friction Clutch**

Protects hoist from damage and prevents overwinding. ER Series couples Weston-style load brake with friction clutch.

**Completely Sealed Body**

Suitable for both indoor and outdoor applications, including harsh environments. Gaskets throughout the hoist provide for an IP55 rating.

**Heat Treated Helical and Spur Gears**

Precision machined for long life. Oil bath lubrication results in a quiet, smooth, cool operation.

**Count Hour Meter**

This maintenance feature, supplied as standard on the ER Series hoists, tracks motor starts, running time and usage history by instant digital display. Meter operates independently of the hoist.

**Easy Maintenance Control Panel**

Simple layout of controls and a single swing-out panel. Hinged controller cover provides standard wiring diagram and allows fast on-site access.

**Superior Quality Chain**

Precision gauged, Grade 80, nickel-plated load chain is heat treated for wear resistance and extended life. Single fall available through 3 Ton.

**Plug-In Connections**

Saves valuable time on setup and maintenance.

“Quick disconnect” replaces typical competitive hard-wired designs.



**Operating Conditions**

Recommended for -4° to +104°F and humidity of 85% or less.



## MR Motorized Trolleys

### Built-In Drop Stops

Important feature provides additional security for the operator and the equipment.



### Sealed Protection

Appropriate for both indoor and outdoor applications, including harsh environments. Gaskets throughout the trolley provide for an IP55 rating.

### Pendant Plug-In Connections

Saves valuable time on setup and maintenance. "Quick disconnect" replaces typical competitive hard-wired designs.

### Rubber Bumpers

Standard feature on all motorized trolleys. Provides protection from collisions. Complies with ASME standards.

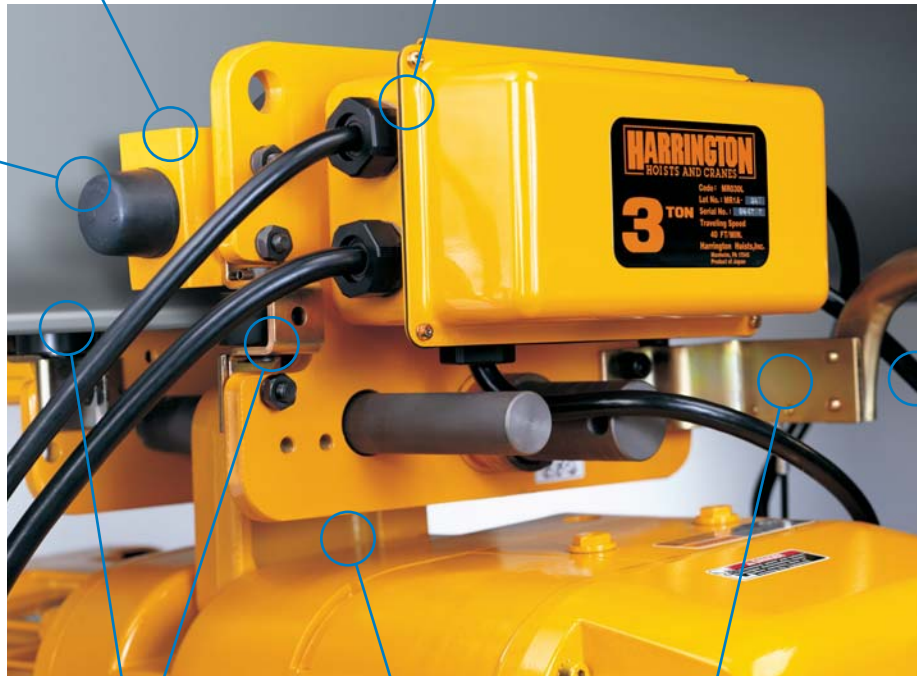

### Power Supply Cord

Standard 30' length is included with cable hangers suitable for festooning.

### Side Guide Rollers

Four ball bearing supported rollers enhance smooth trolley motion and reduce wear of the wheels and beam.

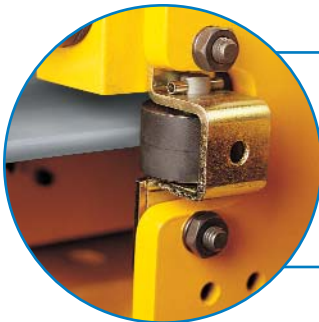

### Cable Support Arm Assembly

Convenient "tow bar" is standard component that gives support and guides the power supply festooning.



### Versatile Suspension

Available in parallel or perpendicular mounts. Semi-rigid lug results in ultimate low headroom and allows limited movement. Ideal for demanding applications.

**Heavy Duty Motor**

Designed for top performance with high-horsepower, 30-minute duty rating, cooling fins and standard thermal motor protection. Motor is totally enclosed, non-ventilated (TENV).

**Motor Gearing**

Grease lubricated, helical gears provide smooth, quiet acceleration and deceleration. Easy exchange of parts for quick speed change.

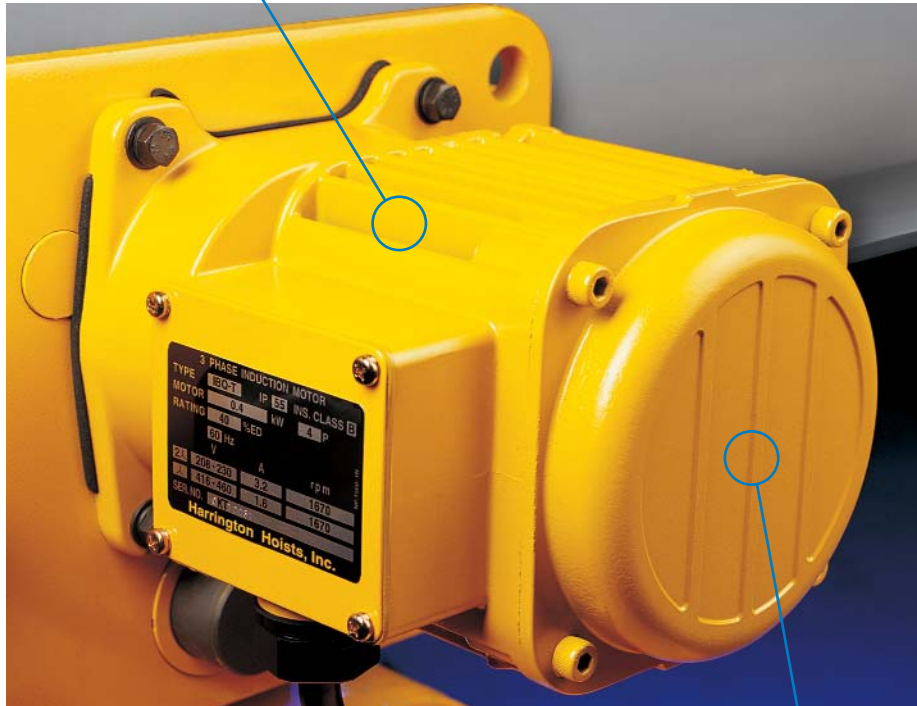

**Universal Tread Wheels**

Operates on both tapered and flat flanged beams. Deep groove ball bearings supply smooth, quiet travel.

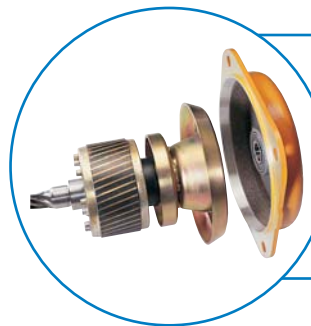

**Pull-Rotor Motor Brake**

Extremely durable and reliable, this advanced design furnishes precision load control, deceleration and long life.

## NER/ER Electric Chain Hoists With Hook and Lug Suspensions

The NER/ER Series of electric chain hoists were designed using the latest technology. The results are high quality, low-headroom, full-featured hoists that provide daily reliable performance in both routine workplace situations and severe working environments.

Refer to pages 4 and 5 for details on features and benefits.

### Standard Hoist Specifications

<p><b>Capacity Range</b> 1/8 Ton–5 Ton (See ER large capacity—pages 26–35)</p> <p><b>Reconnectable Voltage</b> 208-230/460-3-60 for both single and dual speed hoists (optional voltages available)</p> <p><b>Control Voltage</b> 110V (optional 24V and 48V)</p> <p><b>Duty Cycle*</b> Single Speed—60 Min. Dual Speed—30/10 Min.</p> <p><b>Classification*</b> ASME H4 ISO M5 or M4 FEM 2M or 1Am</p> <p><b>Ratings</b> Hoist—IP55 Pendant—IP65</p>	<p><b>Limit Switch</b> Prevents overwinding/overlifting Standard upper</p> <p><b>Chain Falls</b> Single chain fall through 3 Ton (except NER030C)</p> <p><b>Standard Lift</b> 10' (longer lifts available)</p> <p><b>Standard Pendant Drop</b> 4' less than lift (longer drops available)</p> <p><b>Standard Power Supply Cord</b> 15' (longer lengths available)</p> <p><b>Standard Pendants</b> 2-button (Up/Down) Momentary contacts</p> <p><b>Chain Containers</b> Optional Canvas, plastic or steel</p>
---	--

\*See page 48 for additional information.

#### NER vs. ER Features

ER model has same high-quality features as NER plus the following:

- Second brake—Weston-style mechanical load brake
- Count hour meter
- Large capacity—8 Ton–20 Ton





NER/ER010L

## NER/ER Electric Chain Hoists With Hook and Lug Suspensions

### SINGLE SPEED—SPECIFICATIONS

Cap. (Tons)	Product Code	Std. Lift (ft)	Push Button Cord L (ft)	Lifting Speed (ft/min)	Lifting Motor 3 Phase 60 Hz			Load Chain Dia. (mm) x Chain Fall Lines	Net Weight (lbs)	Weight for Additional One Foot of Lift (lbs)
					Output (Hp)	Rated Current (amps)				
						@208-230V	@460V			
1/8	(N)ER001H	10	7.2	57	0.75	4.2	2.1	5.0 x 1	68	0.37
1/4	(N)ER003S			39	0.75	4.2	2.1	5.0 x 1	68	0.37
1/4	(N)ER003H			60	1.2	5.7	2.9	6.3 x 1	84	0.57
1/2	(N)ER005L			15	0.75	4.2	2.1	6.3 x 1	70	0.57
1/2	(N)ER005S			30	1.2	5.7	2.9	6.3 x 1	84	0.57
1	(N)ER010L			16	1.2	5.7	2.9	8.0 x 1	90	0.93
1	NER010M			24	1.9	7.3	3.7	8.0 x 1	110	0.93
1	(N)ER010S			29	2.4	10.5	5.3	8.0 x 1	134	0.93
1 1/2	(N)ER015S			20	2.4	10.5	5.3	10.0 x 1	152	1.5
2	(N)ER020L			14	2.4	10.5	5.3	10.0 x 1	154	1.5
2	NER020M	24	3.8	14.9	7.5	10.0 x 1	181	1.5		
2	(N)ER020S	28	4.7	18.3	9.2	10.0 x 1	240	1.5		
2 1/2	(N)ER025S	23	4.7	18.3	9.2	11.2 x 1	247	1.9		
3	NER030C	8.2		12	3.8	14.9	7.5	10.0 x 2	216	3.1
3	(N)ER030L			16	4.7	18.3	9.2	12.5 x 1	256	2.3
3	(N)ER030S			22	6.2	25.1	12.6	12.5 x 1	269	2.3
5	(N)ER050L			12	4.7	18.3	9.2	11.2 x 2	306	4.0

### SINGLE SPEED—DIMENSIONS

Cap. (Tons)	Product Code	Headroom C (in)	a (in)	b (in)	d (in)	e (in)	g (in)	h (in)	i (in)
1/8	(N)ER001H	13.8	21.1	13.0	10.4	10.7	0.9	4.0	3.9
1/4	(N)ER003S	13.8	21.1	13.0	10.4	10.7	0.9	4.0	3.9
1/4	(N)ER003H	14.6	21.9	13.8	10.8	11.1	0.9	4.7	4.1
1/2	(N)ER005L	14.0	21.1	13.0	10.4	10.7	0.9	4.0	3.9
1/2	(N)ER005S	14.6	21.9	13.8	10.8	11.1	0.9	4.7	4.1
1	(N)ER010L	16.1	21.9	13.8	10.8	11.1	1.2	4.7	4.1
1	NER010M	16.1	23.2	13.8	10.6	12.6	1.2	4.7	4.1
1	(N)ER010S	17.3	25.6	16.5	12.6	13.0	1.2	6.1	5.2
1 1/2	(N)ER015S	19.9	25.6	16.5	12.6	13.0	1.3	6.1	5.2
2	(N)ER020L	22.0	25.6	16.5	12.6	13.0	1.5	6.1	5.2
2	NER020M	22.0	26.9	16.5	12.4	14.4	1.5	6.1	5.2
2	(N)ER020S	24.0	30.9	18.9	15.5	15.5	1.5	7.2	6.5
2 1/2	(N)ER025S	24.6	30.9	18.9	15.5	15.5	1.6	7.2	6.5
3	NER030C	29.5	26.9	16.5	12.4	14.4	1.7	8.2	3.0
3	(N)ER030L	26.0	30.9	18.9	15.5	15.5	1.7	7.2	6.5
3	(N)ER030S	26.0	30.9	18.9	15.5	15.5	1.7	7.2	6.5
5	(N)ER050L	32.9	30.9	18.9	15.5	15.5	1.8	9.6	4.0

**DUAL SPEED—SPECIFICATIONS**

Cap. (Tons)	Product Code	Std. Lift (ft)	Push Button Cord L (ft)	Lifting Speed (ft/min)	Lifting Motor 3 Phase 60 Hz			Load Chain Dia. (mm) x Chain Fall Lines	Net Weight (lbs)	Weight for Additional One Foot of Lift (lbs)
					Output (Hp)	Rated Current (amps)				
						@208-230V	@460V			
1/8	(N)ER001HD	10	7.2	58/19	0.6/0.2	2.9/2.4	1.5/1.2	5.0 x 1	79	0.37
1/4	(N)ER003SD			29/10	0.6/0.2	2.9/2.4	1.5/1.2	5.0 x 1	79	0.37
1/4	(N)ER003HD			60/20	1.2/0.4	5.7/5.1	2.9/2.6	6.3 x 1	101	0.57
1/2	(N)ER005LD			14/5	0.6/0.2	2.9/2.4	1.5/1.2	6.3 x 1	84	0.57
1/2	(N)ER005SD			30/10	1.2/0.4	5.7/5.1	2.9/2.6	6.3 x 1	101	0.57
1	(N)ER010LD			14/5	1.2/0.4	5.7/5.1	2.9/2.6	8.0 x 1	108	0.93
1	(N)ER010SD			29/10	2.4/0.8	9.1/5.7	4.6/2.9	8.0 x 1	152	0.93
1 1/2	(N)ER015SD			20/7	2.4/0.8	9.1/5.7	4.6/2.9	10.0 x 1	168	1.5
2	(N)ER020LD			15/5	2.4/0.8	9.1/5.7	4.6/2.9	10.0 x 1	170	1.5
2	(N)ER020SD			29/10	4.7/1.6	19.6/9.4	9.8/4.7	10.0 x 1	287	1.5
2 1/2	(N)ER025SD	23/8	4.7/1.6	19.6/9.4	9.8/4.7	11.2 x 1	293	1.9		
3	(N)ER030LD	17/6	4.7/1.6	19.6/9.4	9.8/4.7	12.5 x 1	300	2.3		
3	(N)ER030SD	23/8	6.2/2.0	24.1/10.6	12.1/5.3	12.5 x 1	320	2.3		
5	(N)ER050LD	12/4	4.7/1.6	19.6/9.4	9.8/4.7	11.2 x 2	353	4.0		

**DUAL SPEED—DIMENSIONS**

Cap. (Tons)	Product Code	Headroom C (in)	a (in)	b (in)	d (in)	e (in)	g (in)	h (in)	i (in)
1/8	(N)ER001HD	13.8	22.2	13.0	10.4	11.9	0.9	4.0	3.9
1/4	(N)ER003SD	13.8	22.2	13.0	10.4	11.9	0.9	4.0	3.9
1/4	(N)ER003HD	14.6	23.2	13.8	10.6	12.6	0.9	4.7	4.1
1/2	(N)ER005LD	14.0	22.2	13.0	10.4	11.9	0.9	4.0	3.9
1/2	(N)ER005SD	14.6	23.2	13.8	10.6	12.6	0.9	4.7	4.1
1	(N)ER010LD	16.1	23.2	13.8	10.6	12.6	1.2	4.7	4.1
1	(N)ER010SD	17.3	26.9	16.5	12.4	14.4	1.2	6.1	5.2
1 1/2	(N)ER015SD	19.9	26.9	16.5	12.4	14.4	1.3	6.1	5.2
2	(N)ER020LD	22.6	26.9	16.5	12.4	14.4	1.5	6.1	5.2
2	(N)ER020SD	27.0	32.2	18.9	15.5	16.8	1.5	7.2	6.5
2 1/2	(N)ER025SD	27.0	32.2	18.9	15.5	16.8	1.6	7.2	6.5
3	(N)ER030LD	28.5	32.2	18.9	15.5	16.8	1.7	7.2	6.5
3	(N)ER030SD	28.5	32.2	18.9	15.5	16.8	1.7	7.2	6.5
5	(N)ER050LD	35.2	32.2	18.9	15.5	16.8	1.8	9.6	4.0

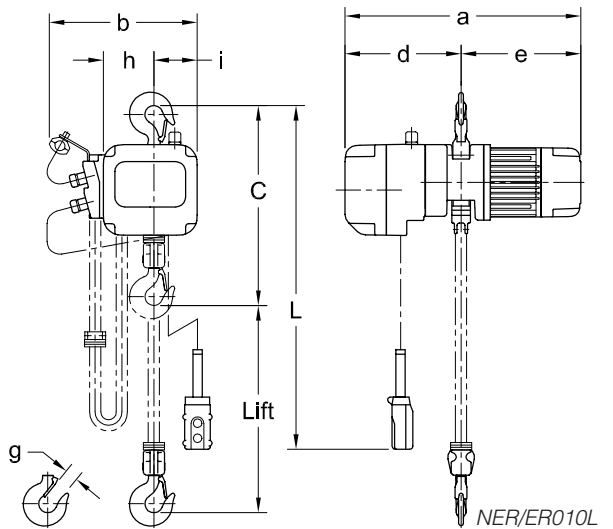

## **NERM/ERM Electric Chain Hoists With Motorized Trolleys**

To further expand the capabilities of our NER/ER line of electric hoists, the MR Series of electric trolleys was developed. They feature an innovative side guide roller system that results in very smooth travel along the beam. Harrington's MR trolley provides the mobility needed in a wide variety of industrial applications.

*Refer to pages 4, 5, 6 and 7 for features and benefits and page 8 for standard hoist specifications.*

### **Standard Motorized Trolley Specifications**

#### **Capacity Range**

1/8 Ton—5 Ton

(See ER large capacity—pages 26–35)

#### **Reconnectable Voltage**

208-230/460-3-60 for  
both single and dual speed trolleys  
(optional voltages available)

#### **Control Voltage**

110V (optional 24V and 48V)

#### **Duty Cycle\***

Single Speed—30 Min.  
Dual Speed—30/10 Min.

#### **Classification\***

ASME H4  
ISO M5 or M4  
FEM 2M or 1Am

#### **Ratings**

Trolley—IP55  
Pendant—IP65

#### **Standard Power Supply Cord**

30' (longer lengths available)

#### **Standard Pendants**

4-button (Up/Dn/For/Rev)  
Momentary contacts

#### **Shafts**

Standard shafts fit wide flange range  
Longer shafts for wider beams  
Spacers for easy adjustments



*\*See page 48 for additional information.*



*NERM/ERM030L-L  
(Shown with  
optional canvas  
chain container.)*



# NERM/ERM Electric Chain Hoists With Motorized Trolleys

## SINGLE SPEED HOIST WITH SINGLE SPEED TROLLEY—SPECIFICATIONS

Cap. (Tons)	Product Code	Std. Lift (ft)	Push Button Cord L (ft)	Lifting Speed (ft/min)	Traversing Speed (ft/min)	Lifting Motor 3 Phase 60 Hz			Traversing Motor 3 Phase 60 Hz			Flange Width Adjustability B (in)		Min. Allow. Radius for Curve (in)	Load Chain Dia. (mm) x Chain Fall Lines	Net Weight (lbs)	Weight for Additional One Foot of Lift (lbs)
						Output (Hp)	Rated Current (amps)		Output (Hp)	Rated Current (amps)		Standard	Optional				
							@208-230V	@460V		@208-230V	@460V						
1/8	(N)ERM001H-L/S	10	7.5	57	L=40 S=80	0.75	4.2	2.1	0.5	3.2	1.6	2.28 to 5.00	5.01 to 6.02 OR 6.03 to 12.00	31.5	5.0 x 1	137	0.37
1/4	(N)ERM003S-L/S			39		0.75	4.2	2.1	0.5	3.2	1.6				5.0 x 1	137	0.37
1/4	(N)ERM003H-L/S			60		1.2	5.7	2.9	0.5	3.2	1.6				6.3 x 1	152	0.57
1/2	(N)ERM005L-L/S			15		0.75	4.2	2.1	0.5	3.2	1.6				6.3 x 1	139	0.57
1/2	(N)ERM005S-L/S			30		1.2	5.7	2.9	0.5	3.2	1.6				6.3 x 1	152	0.57
1	(N)ERM010L-L/S			16		1.2	5.7	2.9	0.5	3.2	1.6				8.0 x 1	159	0.93
1	NERM010M-L/S			24		1.9	7.3	3.7	0.5	3.2	1.6				8.0 x 1	179	0.93
1	(N)ERM010S-L/S			29		2.4	10.5	5.3	0.5	3.2	1.6				8.0 x 1	203	0.93
1 1/2	(N)ERM015S-L/S			20		2.4	10.5	5.3	0.5	3.2	1.6				10.0 x 1	238	1.5
2	(N)ERM020L-L/S			14		2.4	10.5	5.3	0.5	3.2	1.6				10.0 x 1	240	1.5
2	NERM020M-L/S	24	3.8	14.9	7.5	0.5	3.2	1.6	10.0 x 1	267	1.5						
2	(N)ERM020S-L/S	28	4.7	18.3	9.2	0.5	3.2	1.6	10.0 x 1	326	1.5						
2 1/2	(N)ERM025S-L/S	23	4.7	18.3	9.2	0.5	3.2	1.6	3.23 to 6.02	6.03 to 7.02 OR 7.03 to 12.00	39.4	11.2 x 1	353	1.9			
3	NERM030C-L/S	12	3.8	14.9	7.5	0.5	3.2	1.6				10.0 x 2	317	3.1			
3	(N)ERM030L-L/S	16	4.7	18.3	9.2	0.5	3.2	1.6				12.5 x 1	362	2.3			
3	(N)ERM030S-L/S	22	6.2	25.1	12.6	0.5	3.2	1.6	3.94 to 7.01	7.02 to 7.60 OR 7.61 to 12.00	70.9	12.5 x 1	375	2.3			
5	(N)ERM050L-L/S	12	4.7	18.3	9.2	1.0	5.1	2.5				11.2 x 2	461	4.0			

## SINGLE SPEED HOIST WITH SINGLE SPEED TROLLEY—DIMENSIONS

Cap. (Tons)	Product Code	Headroom C (in)	b (in)	b' (in)	d (in)	e (in)	e' (in)	g (in)	i (in)	j (in)	k (in)	m (in)	n (in)	r (in)	t (in)	u (in)
1/8	(N)ERM001H-L/S	14.6	12.4	15.6	8.7	20.3	7.0	0.9	3.74	0.9	5.1	8.0	4.3	2.0	1.22	3.2
1/4	(N)ERM003S-L/S	14.6	12.4	15.6	8.7	20.3	7.0	0.9	3.74	0.9	5.1	8.0	4.3	2.0	1.22	3.2
1/4	(N)ERM003H-L/S	15.4	12.4	15.6	8.7	20.3	7.0	0.9	3.74	0.9	5.1	8.0	4.3	2.0	1.22	3.2
1/2	(N)ERM005L-L/S	14.6	12.4	15.6	8.7	20.3	7.0	0.9	3.74	0.9	5.1	8.0	4.3	2.0	1.22	3.2
1/2	(N)ERM005S-L/S	15.4	12.4	15.6	8.7	20.3	7.0	0.9	3.74	0.9	5.1	8.0	4.3	2.0	1.22	3.2
1	(N)ERM010L-L/S	16.5	12.4	15.6	8.7	20.3	7.0	1.2	3.74	0.9	5.1	8.0	4.3	2.0	1.22	3.2
1	NERM010M-L/S	16.5	12.4	15.6	8.7	20.3	7.0	1.2	3.74	0.9	5.1	8.0	4.3	2.0	1.22	3.2
1	(N)ERM010S-L/S	17.7	12.4	15.6	8.7	20.3	7.0	1.2	3.74	0.9	5.1	8.0	4.3	2.0	1.22	3.2
1 1/2	(N)ERM015S-L/S	19.5	12.8	16.4	8.9	20.5	7.2	1.3	4.33	1.1	4.9	8.3	4.6	2.4	1.42	3.0
2	(N)ERM020L-L/S	21.7	12.8	16.4	8.9	20.5	7.2	1.5	4.33	1.1	4.9	8.3	4.6	2.4	1.42	3.0
2	NERM020M-L/S	21.7	12.8	16.4	8.9	20.5	7.2	1.5	4.33	1.1	4.9	8.3	4.6	2.4	1.42	3.0
2	(N)ERM020S-L/S	23.6	12.8	16.4	8.9	20.5	7.2	1.5	4.33	1.1	4.9	8.3	4.6	2.4	1.42	3.0
2 1/2	(N)ERM025S-L/S	24.2	13.4	17.4	8.9	20.5	7.3	1.6	4.92	1.1	5.2	8.5	5.2	2.7	1.69	2.7
3	NERM030C-L/S	28.9	13.4	17.4	8.9	20.5	7.3	1.7	4.92	1.1	5.2	8.5	5.2	2.7	1.69	2.7
3	(N)ERM030L-L/S	25.4	13.4	17.4	8.9	20.5	7.3	1.7	4.92	1.1	5.2	8.5	5.2	2.7	1.69	2.7
3	(N)ERM030S-L/S	25.4	13.4	17.4	8.9	20.5	7.3	1.7	4.92	1.1	5.2	8.5	5.2	2.7	1.69	2.7
5	(N)ERM050L-L/S	32.7	15.7	19.8	11.1	20.8	7.6	1.8	5.51	1.7	5.7	9.2	5.9	3.4	2.13	1.5

DUAL SPEED HOIST WITH SINGLE SPEED TROLLEY—SPECIFICATIONS

Cap. (Tons)	Product Code	Std. Lift (ft)	Push Button Cord L (ft)	Lifting Speed (ft/min)	Traversing Speed (ft/min)	Lifting Motor 3 Phase 60 Hz			Traversing Motor 3 Phase 60 Hz			Flange Width Adjustability B (in)		Min. Allow. Radius for Curve (in)	Load Chain Dia. (mm) x Chain Fall Lines	Net Weight (lbs)	Weight for Additional One Foot of Lift (lbs)
						Output (Hp)	Rated Current (amps)		Output (Hp)	Rated Current (amps)		Standard	Optional				
							@208-230V	@ 460V		@208-230V	@ 460V						
1/8	(N)ERM001HD-L/S	10	7.5	58/19	L=40 S=80	0.6/0.2	2.9/2.4	1.5/1.2	0.5	3.2	1.6	2.28 to 5.00	5.01 to 6.02 OR 6.03 to 12.00	5.0 x 1	148	0.37	
1/4	(N)ERM003SD-L/S			29/10		0.6/0.2	2.9/2.4	1.5/1.2	0.5	3.2	1.6			5.0 x 1	148	0.37	
1/4	(N)ERM003HD-L/S			60/20		1.2/0.4	5.7/5.1	2.9/2.6	0.5	3.2	1.6			6.3 x 1	170	0.57	
1/2	(N)ERM005LD-L/S			14/5		0.6/0.2	2.9/2.4	1.5/1.2	0.5	3.2	1.6			6.3 x 1	152	0.57	
1/2	(N)ERM005SD-L/S			30/10		1.2/0.4	5.7/5.1	2.9/2.6	0.5	3.2	1.6			6.3 x 1	170	0.57	
1	(N)ERM010LD-L/S			14/5		1.2/0.4	5.7/5.1	2.9/2.6	0.5	3.2	1.6			8.0 x 1	176	0.93	
1	(N)ERM010SD-L/S			29/10		2.4/0.8	9.1/5.7	4.6/2.9	0.5	3.2	1.6			8.0 x 1	220	0.93	
1 1/2	(N)ERM015SD-L/S			20/7		2.4/0.8	9.1/5.7	4.6/2.9	0.5	3.2	1.6	10.0 x 1	254	1.5			
2	(N)ERM020LD-L/S			15/5		2.4/0.8	9.1/5.7	4.6/2.9	0.5	3.2	1.6	10.0 x 1	256	1.5			
2	(N)ERM020SD-L/S			29/10		4.7/1.6	19.6/9.4	9.8/4.7	0.5	3.2	1.6	10.0 x 1	373	1.5			
2 1/2	(N)ERM025SD-L/S			23/8		4.7/1.6	19.6/9.4	9.8/4.7	0.5	3.2	1.6	11.2 x 1	399	1.9			
3	(N)ERM030LD-L/S			17/6		4.7/1.6	19.6/9.4	9.8/4.7	0.5	3.2	1.6	12.5 x 1	406	2.3			
3	(N)ERM030SD-L/S			23/8		6.2/2.0	24.1/10.6	12.1/5.3	0.5	3.2	1.6	12.5 x 1	425	2.3			
5	(N)ERM050LD-L/S			12/4		4.7/1.6	19.6/9.4	9.8/4.7	1.0	5.1	2.5	3.94 to 7.01	7.02 to 7.60 OR 7.61 to 12.00	70.9	11.2 x 2	507	4.0

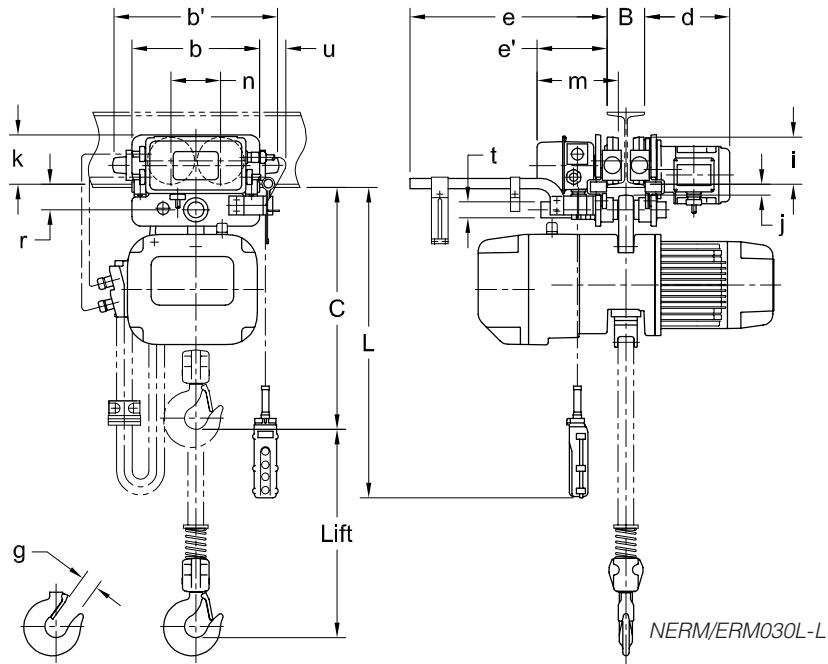

## NERM/ERM Electric Chain Hoists With Motorized Trolleys

### DUAL SPEED HOIST WITH SINGLE SPEED TROLLEY—DIMENSIONS

Cap. (Tons)	Product Code	Headroom C (in)	b (in)	b' (in)	d (in)	e (in)	e' (in)	g (in)	i (in)	j (in)	k (in)	m (in)	n (in)	r (in)	t (in)	u (in)
1/8	(N)ERM001HD-L/S	14.6	12.4	15.6	8.7	20.3	7.0	0.9	3.74	0.9	5.1	8.0	4.3	2.0	1.22	3.2
1/4	(N)ERM003SD-L/S	14.6	12.4	15.6	8.7	20.3	7.0	0.9	3.74	0.9	5.1	8.0	4.3	2.0	1.22	3.2
1/4	(N)ERM003HD-L/S	15.4	12.4	15.6	8.7	20.3	7.0	0.9	3.74	0.9	5.1	8.0	4.3	2.0	1.22	3.2
1/2	(N)ERM005LD-L/S	14.6	12.4	15.6	8.7	20.3	7.0	0.9	3.74	0.9	5.1	8.0	4.3	2.0	1.22	3.2
1/2	(N)ERM005SD-L/S	15.4	12.4	15.6	8.7	20.3	7.0	0.9	3.74	0.9	5.1	8.0	4.3	2.0	1.22	3.2
1	(N)ERM010LD-L/S	16.5	12.4	15.6	8.7	20.3	7.0	1.2	3.74	0.9	5.1	8.0	4.3	2.0	1.22	3.2
1	(N)ERM010SD-L/S	17.7	12.4	15.6	8.7	20.3	7.0	1.2	3.74	0.9	5.1	8.0	4.3	2.0	1.22	3.2
1 1/2	(N)ERM015SD-L/S	19.5	12.8	16.4	8.9	20.5	7.2	1.3	4.33	1.1	4.9	8.3	4.6	2.4	1.42	3.0
2	(N)ERM020LD-L/S	22.2	12.8	16.4	8.9	20.5	7.2	1.5	4.33	1.1	4.9	8.3	4.6	2.4	1.42	3.0
2	(N)ERM020SD-L/S	26.6	12.8	16.4	8.9	20.5	7.2	1.5	4.33	1.1	4.9	8.3	4.6	2.4	1.42	3.0
2 1/2	(N)ERM025SD-L/S	26.6	13.4	17.4	8.9	20.5	7.3	1.6	4.92	1.1	5.2	8.5	5.2	2.7	1.69	2.7
3	(N)ERM030LD-L/S	28.0	13.4	17.4	8.9	20.5	7.3	1.7	4.92	1.1	5.2	8.5	5.2	2.7	1.69	2.7
3	(N)ERM030SD-L/S	28.0	13.4	17.4	8.9	20.5	7.3	1.7	4.92	1.1	5.2	8.5	5.2	2.7	1.69	2.7
5	(N)ERM050LD-L/S	35.0	15.7	19.8	11.1	20.8	7.6	1.8	5.51	1.7	5.7	9.2	5.9	3.4	2.13	1.5

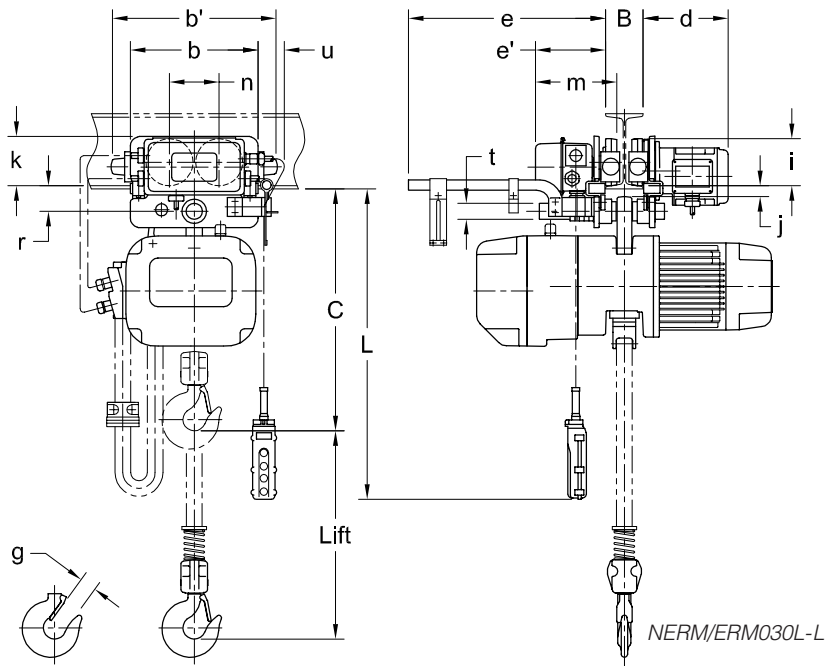

DUAL SPEED HOIST WITH DUAL SPEED TROLLEY—SPECIFICATIONS

Cap. (Tons)	Product Code	Std. Lift (ft)	Push Button Cord L (ft)	Lifting Speed (ft/min)	Traversing Speed (ft/min)	Lifting Motor 3 Phase 60 Hz			Traversing Motor 3 Phase 60 Hz			Flange Width Adjustability B (in)		Min. Allow. Radius for Curve (in)	Load Chain Dia. (mm) x Chain Fall Lines	Net Weight (lbs)	Weight for Additional One Foot of Lift (lbs)
						Output (Hp)	Rated Current (amps)		Output (Hp)	Rated Current (amps)		Standard	Optional				
							@208-230V	@460V		@208-230V	@460V						
1/8	(N)ERM001HD-SD	10	7.5	58/19	80/20	0.6/0.2	2.9/2.4	1.5/1.2	0.4/0.1	2.9/2.2	1.5/1.1	2.28 to 5.00	5.01 to 6.02 OR 6.03 to 12.00	5.0 x 1	157	0.37	
1/4	(N)ERM003SD-SD			29/10		0.6/0.2	2.9/2.4	1.5/1.2	0.4/0.1	2.9/2.2	1.5/1.1			5.0 x 1	157	0.37	
1/4	(N)ERM003HD-SD			60/20		1.2/0.4	5.7/5.1	2.9/2.6	0.4/0.1	2.9/2.2	1.5/1.1			6.3 x 1	179	0.57	
1/2	(N)ERM005LD-SD			14/5		0.6/0.2	2.9/2.4	1.5/1.2	0.4/0.1	2.9/2.2	1.5/1.1			6.3 x 1	161	0.57	
1/2	(N)ERM005SD-SD			30/10		1.2/0.4	5.7/5.1	2.9/2.6	0.4/0.1	2.9/2.2	1.5/1.1			6.3 x 1	179	0.57	
1	(N)ERM010LD-SD			14/5		1.2/0.4	5.7/5.1	2.9/2.6	0.4/0.1	2.9/2.2	1.5/1.1			8.0 x 1	185	0.93	
1	(N)ERM010SD-SD			29/10		2.4/0.8	9.1/5.7	4.6/2.9	0.4/0.1	2.9/2.2	1.5/1.1			8.0 x 1	229	0.93	
1 1/2	(N)ERM015SD-SD			20/7		2.4/0.8	9.1/5.7	4.6/2.9	0.4/0.1	2.9/2.2	1.5/1.1			10.0 x 1	262	1.5	
2	(N)ERM020LD-SD			15/5		2.4/0.8	9.1/5.7	4.6/2.9	0.4/0.1	2.9/2.2	1.5/1.1	10.0 x 1	264	1.5			
2	(N)ERM020SD-SD			29/10		4.7/1.6	19.6/9.4	9.8/4.7	0.4/0.1	2.9/2.2	1.5/1.1	10.0 x 1	381	1.5			
2 1/2	(N)ERM025SD-SD			23/8		4.7/1.6	19.6/9.4	9.8/4.7	0.9/0.2	3.6/3.1	1.8/1.6	11.2 x 1	406	1.9			
3	(N)ERM030LD-SD			17/6		4.7/1.6	19.6/9.4	9.8/4.7	0.9/0.2	3.6/3.1	1.8/1.6	12.5 x 1	412	2.3			
3	(N)ERM030SD-SD			23/8		6.2/2.0	24.1/10.6	12.1/5.3	0.9/0.2	3.6/3.1	1.8/1.6	12.5 x 1	432	2.3			
5	(N)ERM050LD-SD			12/4		4.7/1.6	19.6/9.4	9.8/4.7	0.9/0.2	3.6/3.1	1.8/1.6	7.02 to 7.60 OR 7.61 to 12.00	70.9	11.2 x 2	516	4.0	

DUAL SPEED HOIST WITH DUAL SPEED TROLLEY—DIMENSIONS

Cap. (Tons)	Product Code	Headroom C (in)	b (in)	b' (in)	d (in)	e (in)	e' (in)	g (in)	i (in)	j (in)	k (in)	m (in)	n (in)	r (in)	t (in)	u (in)
1/8	(N)ERM001HD-SD	14.6	12.4	15.6	10.6	20.3	7.0	0.9	3.74	0.9	5.1	8.0	4.3	2.0	1.22	3.2
1/4	(N)ERM003SD-SD	14.6	12.4	15.6	10.6	20.3	7.0	0.9	3.74	0.9	5.1	8.0	4.3	2.0	1.22	3.2
1/4	(N)ERM003HD-SD	15.4	12.4	15.6	10.6	20.3	7.0	0.9	3.74	0.9	5.1	8.0	4.3	2.0	1.22	3.2
1/2	(N)ERM005LD-SD	14.6	12.4	15.6	10.6	20.3	7.0	0.9	3.74	0.9	5.1	8.0	4.3	2.0	1.22	3.2
1/2	(N)ERM005SD-SD	15.4	12.4	15.6	10.6	20.3	7.0	0.9	3.74	0.9	5.1	8.0	4.3	2.0	1.22	3.2
1	(N)ERM010LD-SD	16.5	12.4	15.6	10.6	20.3	7.0	1.2	3.74	0.9	5.1	8.0	4.3	2.0	1.22	3.2
1	(N)ERM010SD-SD	17.7	12.4	15.6	10.6	20.3	7.0	1.2	3.74	0.9	5.1	8.0	4.3	2.0	1.22	3.2
1 1/2	(N)ERM015SD-SD	19.5	12.8	16.4	10.7	20.5	7.2	1.3	4.33	1.1	4.9	8.3	4.6	2.4	1.42	3.0
2	(N)ERM020LD-SD	22.2	12.8	16.4	10.7	20.5	7.2	1.5	4.33	1.1	4.9	8.3	4.6	2.4	1.42	3.0
2	(N)ERM020SD-SD	26.6	12.8	16.4	10.7	20.5	7.2	1.5	4.33	1.1	4.9	8.3	4.6	2.4	1.42	3.0
2 1/2	(N)ERM025SD-SD	26.6	13.4	17.4	10.8	20.5	7.3	1.6	4.92	1.1	5.2	8.5	5.2	2.7	1.69	2.7
3	(N)ERM030LD-SD	28.0	13.4	17.4	10.8	20.5	7.3	1.7	4.92	1.1	5.2	8.5	5.2	2.7	1.69	2.7
3	(N)ERM030SD-SD	28.0	13.4	17.4	10.8	20.5	7.3	1.7	4.92	1.1	5.2	8.5	5.2	2.7	1.69	2.7
5	(N)ERM050LD-SD	35.0	15.7	19.8	11.1	20.8	7.6	1.8	5.51	1.7	5.7	9.2	5.9	3.4	2.13	1.5

## NERP/ERP and NERG/ERG Electric Chain Hoists With Push and Geared Trolleys

Additional options are available based on the application and trolley travel requirements. Mounting our NER/ER Series hoists to either a push or geared trolley will create an easy and economical method of transporting the load. This combination is ideal for small workshops and infrequent moves.

*Refer to page 4 and 5 for features and benefits and page 8 for standard hoist specifications.*

### Standard Manual Trolley Specifications

**Capacity Range**

1/8 Ton–5 Ton

(See ER large capacity—pages 26–35)

**Shafts**

Standard shafts fit wide flange range  
Longer shafts for wider beams  
Spacers for easy adjustments

**Drop Stops**

Standard

**Bumpers**

Optional

**Standard Hand Chain Drop**

On geared trolleys  
2' less than lift (longer drops available)

**Wheels**

All steel  
Shielded ball bearings  
Fit flat or tapered beam flange

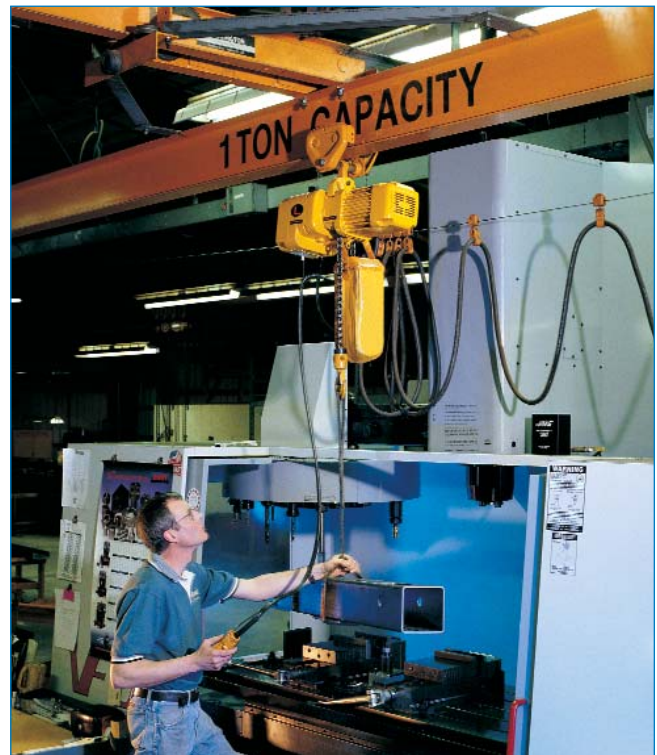





NERP/ERP005L  
(Shown with optional  
steel chain container  
available for  
very long lifts.)



NERG/ERG050L

# NERP/ERP and NERG/ERG Electric Chain Hoists With Push and Geared Trolleys

## SINGLE SPEED HOIST WITH PUSH OR GEARED TROLLEY—SPECIFICATIONS

Cap. (Tons)	Product Code	Std. Lift (ft)	Push Button Cord L (ft)	Lifting Speed (ft/min)	Lifting Motor 3 Phase 60 Hz			Flange Width Adjustability B (in)		Min.* Allow. Radius for Curve (in)	Load Chain Dia. (mm) x Chain Fall Lines	Net Weight (lbs)	Weight for Additional One Foot of Lift (lbs)
					Output (Hp)	Rated Current (amps)		Standard	Optional				
						@208-230V	@460V						
1/8	(N)ERP(ERG)001H	10	7.5	57	0.75	4.2	2.1	2.28 to 4.00 (2.28 to 5.00)	4.01 to 8.00 (5.01 to 8.00) OR 8.01 to 12.00	43.3 (51.2)	5.0 x 1	79 (97)	0.37 (1.0)
1/4	(N)ERP(ERG)003S			39	0.75	4.2	2.1				5.0 x 1	79 (97)	0.37 (1.0)
1/4	(N)ERP(ERG)003H			60	1.2	5.7	2.9				6.3 x 1	95 (115)	0.57 (1.2)
1/2	(N)ERP(ERG)005L			15	0.75	4.2	2.1				6.3 x 1	82 (99)	0.57 (1.2)
1/2	(N)ERP(ERG)005S			30	1.2	5.7	2.9				6.3 x 1	95 (115)	0.57 (1.2)
1	(N)ERP(ERG)010L			16	1.2	5.7	2.9				2.28 to 5.00	5.01 to 8.00 OR 8.01 to 12.00	51.2
1	NERP(NERG)010M			24	1.9	7.3	3.7	8.0 x 1	131 (141)	0.93 (1.5)			
1	(N)ERP(ERG)010S			29	2.4	10.5	5.3	8.0 x 1	154 (165)	0.93 (1.5)			
1 1/2	(N)ERP(ERG)015S			20	2.4	10.5	5.3	3.23 to 6.02	6.03 to 12.00	59.1	10.0 x 1	187 (198)	1.5 (2.2)
2	(N)ERP(ERG)020L			14	2.4	10.5	5.3				10.0 x 1	190 (201)	1.5 (2.2)
2	NERP(NERG)020M			24	3.8	14.9	7.5				10.0 x 1	216 (227)	1.5 (2.2)
2	(N)ERP(ERG)020S			28	4.7	18.3	9.2				10.0 x 1	276 (287)	1.5 (2.2)
2 1/2	(N)ERP(ERG)025S			23	4.7	18.3	9.2				11.2 x 1	300 (311)	1.9 (2.6)
3	NERP(NERG)030C			12	3.8	14.9	7.5				10.0 x 2	260 (282)	3.1 (3.7)
3	(N)ERP(ERG)030L	16	4.7	18.3	9.2	66.9	12.5 x 1	311 (322)	2.3 (2.9)				
3	(N)ERP(ERG)030S	22	6.2	25.1	12.6		12.5 x 1	324 (335)	2.3 (2.9)				
5	(N)ERP(ERG)050L	12	4.7	18.3	9.2		3.94 to 7.02	7.03 to 12.00	90.6	11.2 x 2	417 (432)	4.0 (4.6)	

Figures in parentheses are data for geared trolley.

\*Minimum flange width for curved beam: 1 Ton Push and 1/8 to 1 Ton Geared = 2.87 in.; 3 Ton Push and Geared = 3.50 in.

## SINGLE SPEED HOIST WITH PUSH TROLLEY—DIMENSIONS

Cap. (Tons)	Product Code	Headroom C (in)	a (in)	b (in)	e (in)	g (in)	h (in)	i (in)	j (in)	k (in)	m (in)	n (in)	r (in)	t (in)
1/8	(N)ERP001H	15.4	8.0	7.2	1.8	0.9	3.2	2.36	0.7	3.0	1.9	3.3	1.5	0.87
1/4	(N)ERP003S	15.4	8.0	7.2	1.8	0.9	3.2	2.36	0.7	3.0	1.9	3.3	1.5	0.87
1/4	(N)ERP003H	16.1	8.0	7.2	1.8	0.9	3.2	2.36	0.7	3.0	1.9	3.3	1.5	0.87
1/2	(N)ERP005L	15.4	8.0	7.2	1.8	0.9	3.2	2.36	0.7	3.0	1.9	3.3	1.5	0.87
1/2	(N)ERP005S	16.1	8.0	7.2	1.8	0.9	3.2	2.36	0.7	3.0	1.9	3.3	1.5	0.87
1	(N)ERP010L	18.1	9.8	9.3	2.2	1.2	4.2	2.80	1.1	3.7	2.2	4.4	2.0	0.98
1	NERP010M	18.1	9.8	9.3	2.2	1.2	4.2	2.80	1.1	3.7	2.2	4.4	2.0	0.98
1	(N)ERP010S	19.5	9.8	9.3	2.2	1.2	4.2	2.80	1.1	3.7	2.2	4.4	2.0	0.98
1 1/2	(N)ERP015S	21.9	11.8	11.0	2.7	1.3	5.0	3.35	1.3	4.4	2.8	5.2	2.4	1.26
2	(N)ERP020L	24.0	11.8	11.0	2.7	1.5	5.0	3.35	1.3	4.4	2.8	5.2	2.4	1.26
2	NERP020M	24.0	11.8	11.0	2.7	1.5	5.0	3.35	1.3	4.4	2.8	5.2	2.4	1.26
2	(N)ERP020S	26.0	11.8	11.0	2.7	1.5	5.0	3.35	1.3	4.4	2.8	5.2	2.4	1.26
2 1/2	(N)ERP025S	26.6	12.6	12.8	3.1	1.6	5.8	3.94	1.4	5.3	3.1	6.0	2.7	1.42
3	NERP030C	29.3	12.6	12.8	3.1	1.7	5.8	3.94	1.4	5.3	3.1	6.0	2.7	1.42
3	(N)ERP030L	27.8	12.6	12.8	3.1	1.7	5.8	3.94	1.4	5.3	3.1	6.0	2.7	1.42
3	(N)ERP030S	27.8	12.6	12.8	3.1	1.7	5.8	3.94	1.4	5.3	3.1	6.0	2.7	1.42
5	(N)ERP050L	32.5	11.7	15.7	2.1	1.8	6.7	4.65	1.8	5.7	3.2	7.0	3.5	2.13

SINGLE SPEED HOIST WITH GEARED TROLLEY—DIMENSIONS

Cap. (Tons)	Product Code	Headroom C (in)	E (ft)	a (in)	b (in)	e (in)	g (in)	h (in)	i (in)	j (in)	k (in)	k' (in)	m (in)	n (in)	r (in)	t (in)	u (in)
1/8	(N)ERG001H	16.1	10.5	13.6	9.3	6.0	0.9	4.2	2.80	1.1	3.7	4.2	2.2	4.4	2.0	0.98	7.2
1/4	(N)ERG003S	16.1	10.5	13.6	9.3	6.0	0.9	4.2	2.80	1.1	3.7	4.2	2.2	4.4	2.0	0.98	7.2
1/4	(N)ERG003H	16.9	10.5	13.6	9.3	6.0	0.9	4.2	2.80	1.1	3.7	4.2	2.2	4.4	2.0	0.98	7.2
1/2	(N)ERG005L	16.1	10.5	13.6	9.3	6.0	0.9	4.2	2.80	1.1	3.7	4.2	2.2	4.4	2.0	0.98	7.2
1/2	(N)ERG005S	16.9	10.5	13.6	9.3	6.0	0.9	4.2	2.80	1.1	3.7	4.2	2.2	4.4	2.0	0.98	7.2
1	(N)ERG010L	18.1	10.5	13.6	9.3	6.0	1.2	4.2	2.80	1.1	3.7	4.2	2.2	4.4	2.0	0.98	7.2
1	NERG010M	18.1	10.5	13.6	9.3	6.0	1.2	4.2	2.80	1.1	3.7	4.2	2.2	4.4	2.0	0.98	7.2
1	(N)ERG010S	19.5	10.5	13.6	9.3	6.0	1.2	4.2	2.80	1.1	3.7	4.2	2.2	4.4	2.0	0.98	7.2
1 1/2	(N)ERG015S	21.9	10.5	15.2	11.0	6.1	1.3	5.0	3.35	1.3	4.4	4.3	2.8	5.2	2.4	1.26	7.2
2	(N)ERG020L	24.0	10.5	15.2	11.0	6.1	1.5	5.0	3.35	1.3	4.4	4.3	2.8	5.2	2.4	1.26	7.2
2	NERG020M	24.0	10.5	15.2	11.0	6.1	1.5	5.0	3.35	1.3	4.4	4.3	2.8	5.2	2.4	1.26	7.2
2	(N)ERG020S	26.0	10.5	15.2	11.0	6.1	1.5	5.0	3.35	1.3	4.4	4.3	2.8	5.2	2.4	1.26	7.2
2 1/2	(N)ERG025S	26.6	11.0	15.7	12.8	6.2	1.6	5.8	3.94	1.4	5.3	4.5	3.1	6.0	2.7	1.42	7.2
3	NERG030C	29.3	11.0	15.7	12.8	6.2	1.7	5.8	3.94	1.4	5.3	4.5	3.1	6.0	2.7	1.42	7.2
3	(N)ERG030L	27.8	11.0	15.7	12.8	6.2	1.7	5.8	3.94	1.4	5.3	4.5	3.1	6.0	2.7	1.42	7.2
3	(N)ERG030S	27.8	11.0	15.7	12.8	6.2	1.7	5.8	3.94	1.4	5.3	4.5	3.1	6.0	2.7	1.42	7.2
5	(N)ERG050L	32.5	11.4	15.8	15.7	6.1	1.8	6.7	4.65	1.8	5.7	5.2	3.2	7.0	3.5	2.13	7.2

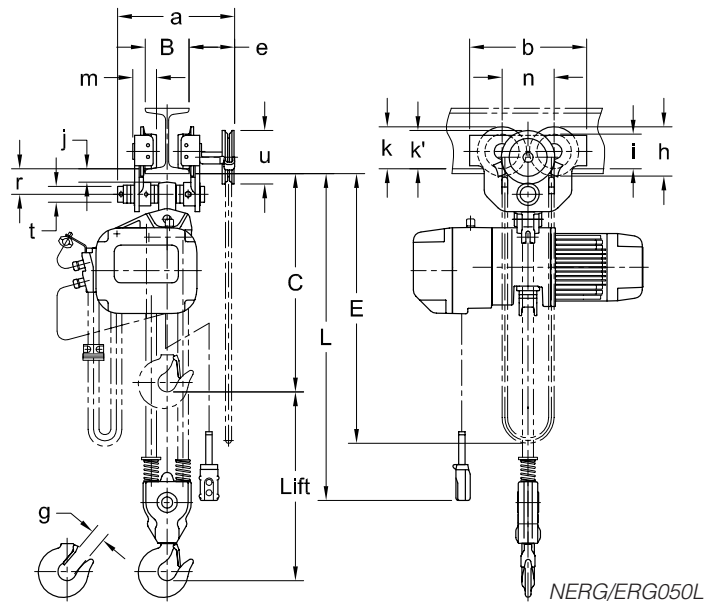
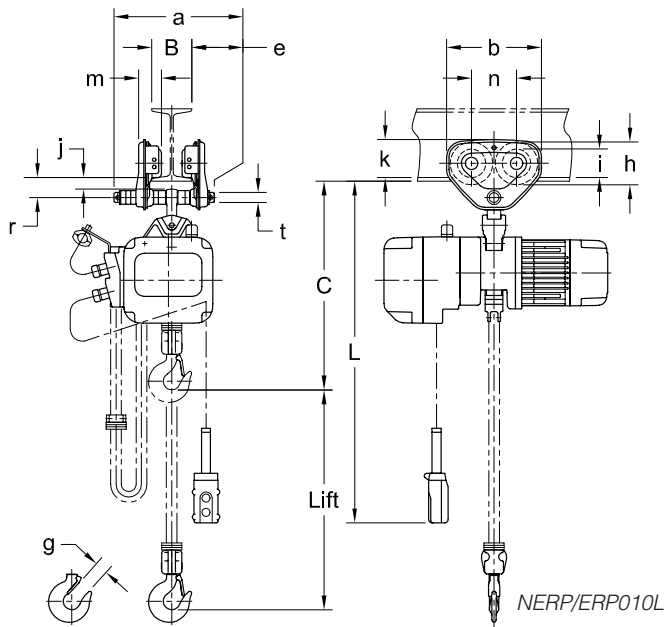

# NERP/ERP and NERG/ERG Electric Chain Hoists With Push and Geared Trolleys

## DUAL SPEED HOIST WITH PUSH OR GEARED TROLLEY—SPECIFICATIONS

Cap. (Tons)	Product Code	Std. Lift (ft)	Push Button Cord L (ft)	Lifting Speed (ft/min)	Lifting Motor 3 Phase 60 Hz			Flange Width Adjustability B (in)		Min.* Allow. Radius for Curve (in)	Load Chain Dia. (mm) x Chain Fall Lines	Net Weight (lbs)	Weight for Additional One Foot of Lift (lbs)
					Output (Hp)	Rated Current (amps)		Standard	Optional				
						@208-230V	@460V						
1/8	(N)ERP(ERG)001HD	10	7.5	58/19	0.6/0.2	2.9/2.4	1.5/1.2	2.28 to 4.00 (2.28 to 5.00)	4.01 to 8.00 (5.01 to 8.00) OR 8.01 to 12.00	43.3 (51.2)	5.0 x 1	90 (108)	0.37 (1.0)
1/4	(N)ERP(ERG)003SD			29/10	0.6/0.2	2.9/2.4	1.5/1.2				5.0 x 1	90 (108)	0.37 (1.0)
1/4	(N)ERP(ERG)003HD			60/20	1.2/0.4	5.7/5.1	2.9/2.6				6.3 x 1	112 (132)	0.57 (1.2)
1/2	(N)ERP(ERG)005LD			14/5	0.6/0.2	2.9/2.4	1.5/1.2				6.3 x 1	95 (112)	0.57 (1.2)
1/2	(N)ERP(ERG)005SD			30/10	1.2/0.4	5.7/5.1	2.9/2.6				6.3 x 1	112(132)	0.57 (1.2)
1	(N)ERP(ERG)010LD			14/5	1.2/0.4	5.7/5.1	2.9/2.6	2.28 to 5.00	5.01 to 8.00 OR 8.01 to 12.00	51.2	8.0 x 1	128 (139)	0.93 (1.5)
1	(N)ERP(ERG)010SD			29/10	2.4/0.8	9.1/5.7	4.6/2.9				8.0 x 1	172 (183)	0.93 (1.5)
1 1/2	(N)ERP(ERG)015SD			20/7	2.4/0.8	9.1/5.7	4.6/2.9	3.23 to 6.02	6.03 to 12.00	59.1	10.0 x 1	203 (214)	1.5 (2.2)
2	(N)ERP(ERG)020LD			15/5	2.4/0.8	9.1/5.7	4.6/2.9				10.0 x 1	205 (216)	1.5 (2.2)
2	(N)ERP(ERG)020SD			29/10	4.7/1.6	19.6/9.4	9.8/4.7				10.0 x 1	322 (333)	1.5 (2.2)
2 1/2	(N)ERP(ERG)025SD	23/8	4.7/1.6	19.6/9.4	9.8/4.7	66.9	11.2 x 1			346 (357)	1.9 (2.6)		
3	(N)ERP(ERG)030LD	17/6	4.7/1.6	19.6/9.4	9.8/4.7		12.5 x 1			355 (366)	2.3 (2.9)		
3	(N)ERP(ERG)030SD	23/8	6.2/2.0	24.1/10.6	12.1/5.3	3.94 to 7.02	7.03 to 12.00	90.6	12.5 x 1	375(386)	2.3 (2.9)		
5	(N)ERP(ERG)050LD	12/4	4.7/1.6	19.6/9.4	9.8/4.7				11.2 x 2	463 (478)	4.0 (4.6)		

Figures in parentheses are data for geared trolley.

\*Minimum flange width for curved beam: 1 Ton Push and 1/8 to 1 Ton Geared = 2.87 in.; 3 Ton Push and Geared = 3.50 in.

## DUAL SPEED HOIST WITH PUSH TROLLEY—DIMENSIONS

Cap. (Tons)	Product Code	Headroom C (in)	a (in)	b (in)	e (in)	g (in)	h (in)	i (in)	j (in)	k (in)	m (in)	n (in)	r (in)	t (in)
1/8	(N)ERP001HD	15.4	8.0	7.2	1.8	0.9	3.2	2.36	0.7	3.0	1.9	3.3	1.5	0.87
1/4	(N)ERP003SD	15.4	8.0	7.2	1.8	0.9	3.2	2.36	0.7	3.0	1.9	3.3	1.5	0.87
1/4	(N)ERP003HD	16.1	8.0	7.2	1.8	0.9	3.2	2.36	0.7	3.0	1.9	3.3	1.5	0.87
1/2	(N)ERP005LD	15.4	8.0	7.2	1.8	0.9	3.2	2.36	0.7	3.0	1.9	3.3	1.5	0.87
1/2	(N)ERP005SD	16.1	8.0	7.2	1.8	0.9	3.2	2.36	0.7	3.0	1.9	3.3	1.5	0.87
1	(N)ERP010LD	18.1	9.8	9.3	2.2	1.2	4.2	2.80	1.1	3.7	2.2	4.4	2.0	0.98
1	(N)ERP010SD	19.5	9.8	9.3	2.2	1.2	4.2	2.80	1.1	3.7	2.2	4.4	2.0	0.98
1 1/2	(N)ERP015SD	21.9	11.8	11.0	2.7	1.3	5.0	3.35	1.3	4.4	2.8	5.2	2.4	1.26
2	(N)ERP020LD	24.6	11.8	11.0	2.7	1.5	5.0	3.35	1.3	4.4	2.8	5.2	2.4	1.26
2	(N)ERP020SD	28.9	11.8	11.0	2.7	1.5	5.0	3.35	1.3	4.4	2.8	5.2	2.4	1.26
2 1/2	(N)ERP025SD	28.9	12.6	12.8	3.1	1.6	5.8	3.94	1.4	5.3	3.1	6.0	2.7	1.42
3	(N)ERP030LD	30.3	12.6	12.8	3.1	1.7	5.8	3.94	1.4	5.3	3.1	6.0	2.7	1.42
3	(N)ERP030SD	30.3	12.6	12.8	3.1	1.7	5.8	3.94	1.4	5.3	3.1	6.0	2.7	1.42
5	(N)ERP050LD	34.8	11.7	15.7	2.1	1.8	6.7	4.65	1.8	5.7	3.2	7.0	3.5	2.13

DUAL SPEED HOIST WITH GEARED TROLLEY—DIMENSIONS

Cap. (Tons)	Product Code	Headroom C (in)	E (ft)	a (in)	b (in)	e (in)	g (in)	h (in)	i (in)	j (in)	k (in)	k' (in)	m (in)	n (in)	r (in)	t (in)	u (in)
1/8	(N)ERG001HD	16.1	10.5	13.6	9.3	6.0	0.9	4.2	2.80	1.1	3.7	4.2	2.2	4.4	2.0	0.98	7.2
1/4	(N)ERG003SD	16.1	10.5	13.6	9.3	6.0	0.9	4.2	2.80	1.1	3.7	4.2	2.2	4.4	2.0	0.98	7.2
1/4	(N)ERG003HD	16.9	10.5	13.6	9.3	6.0	0.9	4.2	2.80	1.1	3.7	4.2	2.2	4.4	2.0	0.98	7.2
1/2	(N)ERG005LD	16.1	10.5	13.6	9.3	6.0	0.9	4.2	2.80	1.1	3.7	4.2	2.2	4.4	2.0	0.98	7.2
1/2	(N)ERG005SD	16.9	10.5	13.6	9.3	6.0	0.9	4.2	2.80	1.1	3.7	4.2	2.2	4.4	2.0	0.98	7.2
1	(N)ERG010LD	18.1	10.5	13.6	9.3	6.0	1.2	4.2	2.80	1.1	3.7	4.2	2.2	4.4	2.0	0.98	7.2
1	(N)ERG010SD	19.5	10.5	13.6	9.3	6.0	1.2	4.2	2.80	1.1	3.7	4.2	2.2	4.4	2.0	0.98	7.2
1 1/2	(N)ERG015SD	21.9	10.5	15.2	11.0	6.1	1.3	5.0	3.35	1.3	4.4	4.3	2.7	5.2	2.4	1.26	7.2
2	(N)ERG020LD	24.6	10.5	15.2	11.0	6.1	1.5	5.0	3.35	1.3	4.4	4.3	2.7	5.2	2.4	1.26	7.2
2	(N)ERG020SD	28.9	10.5	15.2	11.0	6.1	1.5	5.0	3.35	1.3	4.4	4.3	2.7	5.2	2.4	1.26	7.2
2 1/2	(N)ERG025SD	28.9	11.0	15.7	12.8	6.2	1.6	5.8	3.94	1.4	5.3	4.5	3.1	6.0	2.7	1.42	7.2
3	(N)ERG030LD	30.3	11.0	15.7	12.8	6.2	1.7	5.8	3.94	1.4	5.3	4.5	3.1	6.0	2.7	1.42	7.2
3	(N)ERG030SD	30.3	11.0	15.7	12.8	6.2	1.7	5.8	3.94	1.4	5.3	4.5	3.1	6.0	2.7	1.42	7.2
5	(N)ERG050LD	34.8	11.4	15.8	15.7	6.1	1.8	6.7	4.65	1.8	5.7	5.2	3.2	7.0	3.5	2.13	7.2

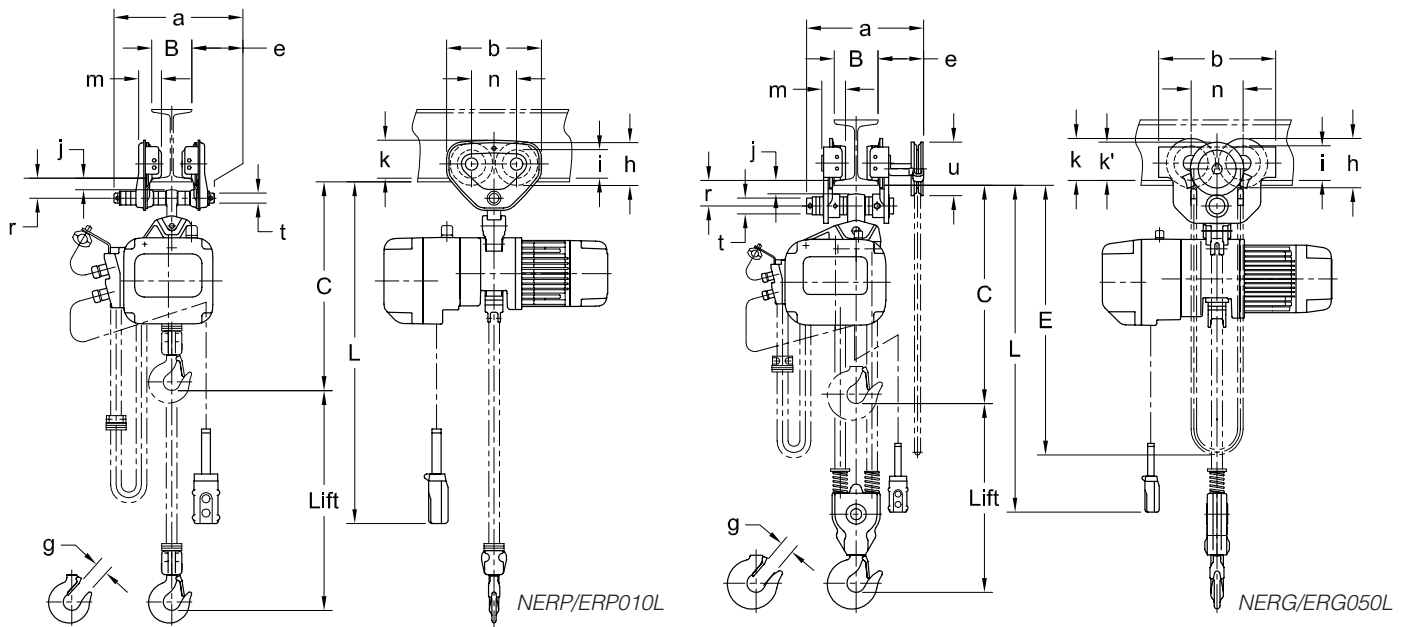



## NER/ER Cylinder Control Electric Chain Hoists With Hook and Lug Suspensions

We have expanded the benefits of the ergonomically designed cylinder control into our full-featured NER/ER Series of electric chain hoists. For three-phase applications requiring ease of control, one-handed operation, fast lifting speeds and heavy duty production, these hoists will increase productivity, add to operator comfort and answer your ergonomic needs.

*Refer to pages 4 and 5 for features and benefits and page 8 for standard hoist specifications.*

### Unique Features and Benefits

#### **In-Line Handgrip**

Unique cylinder control replaces standard pendant. Design permits one-handed operation and gives the operator a free hand to easily position the load. Cylinder control kit is available with hoist or as kit for field installation.

#### **High/Low Speeds**

Easy touch rocker switch above handgrip on dual speed models allows quick selection between low and high speeds.

#### **Removable Bottom Hook**

Permits insertion of a variety of below-the-hook material handling devices.



NER003SDCC

### Unique Hoist Specifications

#### **Capacity Range**

1/8 Ton–1/4 Ton

#### **Standard Lift**

6' (other lifts not available)

#### **Standard Reach**

9' (approx.)  
(reach equals lift plus headroom)

#### **Chain Containers**

Standard  
Plastic

**SINGLE SPEED—SPECIFICATIONS**

Cap. (Tons)	Product Code	Std. Lift (ft)	Lifting Speed (ft/min)	Lifting Motor 3 Phase 60 Hz			Load Chain Dia. (mm) x Chain Fall Lines	Net Weight (lbs)
				Output (Hp)	Rated Current (amps)			
					@208-230V	@460V		
1/8	(N)ER001HCC	6	57	0.75	4.2	2.1	5.0 x 1	68
1/4	(N)ER003SCC		39	0.75	4.2	2.1	5.0 x 1	68

**SINGLE SPEED—DIMENSIONS**

Cap. (Tons)	Product Code	Headroom C (in)	D (in)	a (in)	b (in)	d (in)	e (in)	f (in)	g (in)	h (in)	i (in)
1/8	(N)ER001HCC	40.6	17.7	21.1	13.0	10.4	10.7	10.4	1.0	4.0	3.9
1/4	(N)ER003SCC	40.6	17.7	21.1	13.0	10.4	10.7	10.4	1.0	4.0	3.9

**DUAL SPEED—SPECIFICATIONS**

Cap. (Tons)	Product Code	Std. Lift (ft)	Lifting Speed (ft/min)	Lifting Motor 3 Phase 60 Hz			Load Chain Dia. (mm) x Chain Fall Lines	Net Weight (lbs)
				Output (Hp)	Rated Current (amps)			
					@208-230V	@460V		
1/8	(N)ER001HDCC	6	58/19	0.6/0.2	2.9/2.4	1.5/1.2	5.0 x 1	79
1/4	(N)ER003SDCC		29/10	0.6/0.2	2.9/2.4	1.5/1.2	5.0 x 1	79

**DUAL SPEED—DIMENSIONS**

Cap. (Tons)	Product Code	Headroom C (in)	D (in)	a (in)	b (in)	d (in)	e (in)	f (in)	g (in)	h (in)	i (in)
1/8	(N)ER001HDCC	40.6	17.7	22.2	13.0	10.4	11.9	10.4	1.0	4.0	3.9
1/4	(N)ER003SDCC	40.6	17.7	22.2	13.0	10.4	11.9	10.4	1.0	4.0	3.9

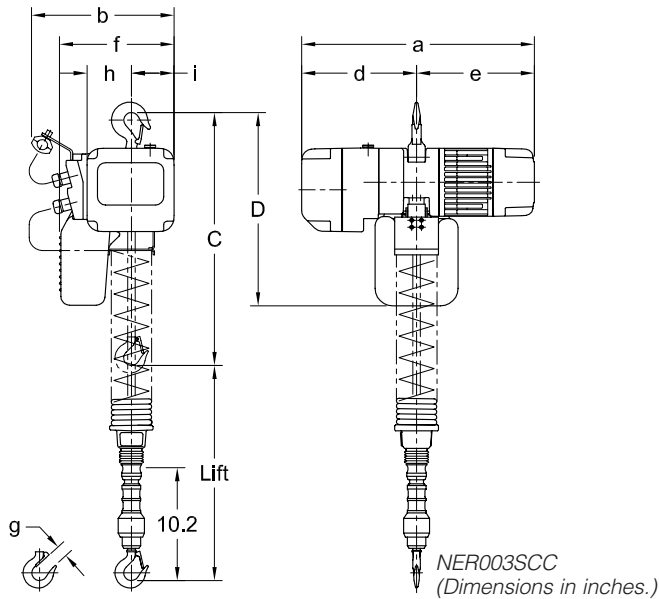

## ER Large Capacity Electric Chain Hoists With Hook and Lug Suspensions

Our ER Series of electric chain hoists was specifically developed for high performance. To handle the heavier loads, our full line of large capacity hoists provide the duty cycle, durability and ease of operation needed to support most lifting applications. Regardless if the job is a one-time lift or an everyday situation, the ER electric chain hoist will work harder for you.

Refer to pages 4 and 5 for features and benefits.

### Standard Hoist Specifications

**Large Capacity Range**

8 Ton–20 Ton

**Reconnectable Voltage**

208-230/460-3-60 for both single and dual speed hoists (optional voltages available)

**Control Voltage**

110V (optional 24V and 48V)

**Duty Cycle\***

Single Speed—60 Min.  
Dual Speed—30/10 Min.

**Classification\***

ASME H4  
ISO M5 or M4  
FEM 2M or 1Am

**Ratings**

Hoist—IP55  
Pendant—IP65

**Limit Switch**

Prevents overwinding/overlifting  
Standard upper/lower

**Standard Lift**

10' (longer lifts available)

**Standard Pendant Drop**

4' less than lift (longer drops available)

**Standard Power Supply Cord**

30' (longer lengths available)

**Standard Pendants**

2-button (Up/Down)  
Momentary contacts

**Chain Containers**

Optional  
Canvas or steel



ER100S  
(Shown with optional canvas chain containers.)

\*See page 48 for additional information.

**SINGLE SPEED—SPECIFICATIONS**

Cap. (Tons)	Product Code	Std. Lift (ft)	Push Button Cord L (ft)	Lifting Speed (ft/min)	Lifting Motor 3 Phase 60 Hz			Load Chain Dia. (mm) x Chain Fall Lines	Net Weight (lbs)	Weight for Additional One Foot of Lift (lbs)
					Output (Hp)	Rated Current (amps)				
						@208-230V	@460V			
8	ER080S*	10	8.7	8	4.7	18.3	9.2	11.2 x 3	439	5.9
10	ER100L		9.2	6	4.7	18.3	9.2	11.2 x 4	597	8.1
10	ER100L-LG		8.7	6	4.7	18.3	9.2	11.2 x 4	496	8.1
10	ER100S		9.2	12	4.7 x 2	18.3 x 2	9.2 x 2	11.2 x 4	683	8.1
15	ER150S		10.5	8	4.7 x 2	18.3 x 2	9.2 x 2	11.2 x 6	897	12.1
20	ER200S			6	4.7 x 2	18.3 x 2	9.2 x 2	11.2 x 8	1065	16.1

\*Available lug mount only. Push button cord dimension (L) is to center of lug hole.

**SINGLE SPEED—DIMENSIONS**

Cap. (Tons)	Product Code	Headroom C (in)	a (in)	b (in)	d (in)	e (in)	g (in)	h (in)	i (in)
8	ER080S	42.0	30.9	23.8	15.5	15.5	2.4	11.3	7.5
10	ER100L	52.6	30.9	39.4	15.5	15.5	2.4	14.0	20.4
10	ER100L-LG	39.7	30.9	28.0	15.5	15.5	2.4	14.0	8.9
10	ER100S	52.6	30.9	34.2	15.5	15.5	2.4	—	—
15	ER150S	60.6	30.9	41.3	15.5	15.5	3.1	—	—
20	ER200S	65.0	30.9	49.1	15.5	15.5	3.4	—	—

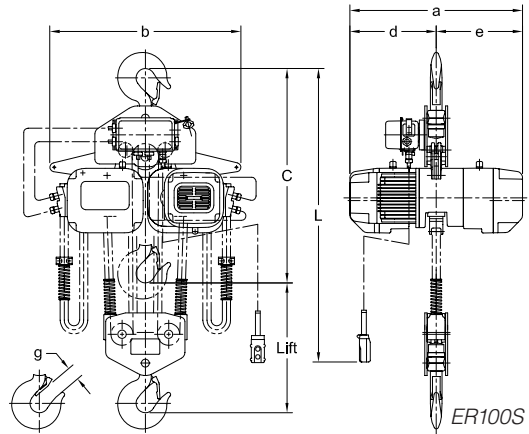

**DUAL SPEED—SPECIFICATIONS**

Cap. (Tons)	Product Code	Std. Lift (ft)	Push Button Cord L (ft)	Lifting Speed (ft/min)	Lifting Motor 3 Phase 60 Hz			Load Chain Dia. (mm) x Chain Fall Lines	Net Weight (lbs)	Weight for Additional One Foot of Lift (lbs)
					Output (Hp)	Rated Current (amps)				
						@208-230V	@460V			
8	ER080SD*	10	8.7	8/3	4.7/1.6	19.6/9.4	9.8/4.7	11.2 x 3	485	5.9
10	ER100LD		9.2	6/2	4.7/1.6	19.6/9.4	9.8/4.7	11.2 x 4	642	8.1
10	ER100LD-LG		8.7	6/2	4.7/1.6	19.6/9.4	9.8/4.7	11.2 x 4	542	8.1
10	ER100SD		9.2	12/4	4.7/1.6 x 2	19.6/9.4 x 2	9.8/4.7 x 2	11.2 x 4	772	8.1
15	ER150SD		10.5	8/3	4.7/1.6 x 2	19.6/9.4 x 2	9.8/4.7 x 2	11.2 x 6	985	12.1
20	ER200SD			6/2	4.7/1.6 x 2	19.6/9.4 x 2	9.8/4.7 x 2	11.2 x 8	1153	16.1

\*Available lug mount only. Push button cord dimension (L) is to center of lug hole.

**DUAL SPEED—DIMENSIONS**

Cap. (Tons)	Product Code	Headroom C (in)	a (in)	b (in)	d (in)	e (in)	g (in)	h (in)	i (in)
8	ER080SD	42.0	32.2	23.8	15.5	16.8	2.4	11.3	7.5
10	ER100LD	52.6	32.2	39.4	15.5	16.8	2.4	14.0	20.4
10	ER100LD-LG	39.7	32.2	28.0	15.5	16.8	2.4	14.0	8.9
10	ER100SD	52.6	33.5	34.2	16.8	16.8	2.4	—	—
15	ER150SD	60.6	33.5	41.3	16.8	16.8	3.1	—	—
20	ER200SD	65.0	33.5	49.1	16.8	16.8	3.4	—	—

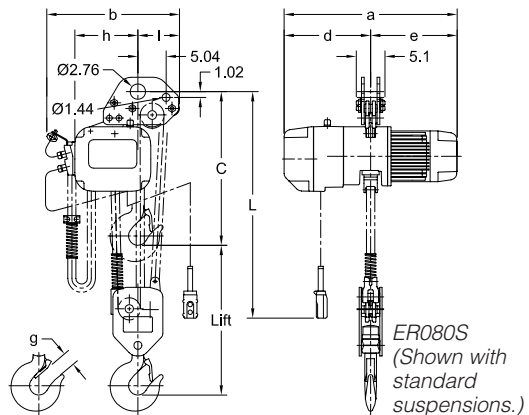

## ERM Large Capacity Electric Chain Hoists With Motorized Trolleys

Our large capacity MR Series of motorized trolleys offers the horsepower and precision required to transport and position extremely heavy loads. Designed with either 4 or 8 wheels to spread the weight across a wider wheel base, they easily move the ER large capacity hoist and its load from one location to the next.

Refer to pages 4, 5, 6 and 7 for features and benefits and page 26 for standard hoist specifications.

### Standard Motorized Trolley Specifications

**Capacity Range**

8 Ton–20 Ton

**Reconnectable Voltage**

208-230/460-3-60  
(optional voltages available)

**Control Voltage**

110V (optional 24V and 48V)

**Duty Cycle\***

Single Speed—30 Min.

**Classification\***

ASME H4  
ISO M5 or M4  
FEM 2M or 1Am

**Ratings**

Trolley—IP55  
Pendant—IP65

**Standard Power Supply Cord**

30' (longer lengths available)

**Standard Pendants**

4-button (Up/Dn/For/Rev)  
Momentary contacts

**Shafts**

Standard shafts fit wide flange range  
Longer shafts for wider beams  
Spacers for easy adjustments



ERM100L-L  
(Shown with  
optional canvas  
chain container.)

\*See page 48 for additional information.



**SINGLE SPEED HOIST WITH SINGLE SPEED TROLLEY—SPECIFICATIONS**

Cap. (Tons)	Product Code	Std. Lift (ft)	Push Button Cord L (ft)	Lifting Speed (ft/min)	Traversing Speed (ft/min)	Lifting Motor 3 Phase 60 Hz			Traversing Motor 3 Phase 60 Hz			Flange Width Adjustability B (in)		Min. Allow. Radius for Curve (in)	Load Chain Dia. (mm) x Chain Fall Lines	Net Weight (lbs)	Weight for Additional One Foot of Lift (lbs)
						Output (Hp)	Rated Current (amps)		Output (Hp)	Rated Current (amps)		Standard	Optional				
							@208-230V	@ 460V		@208-230V	@ 460V						
8	ERM080S-L	10	9.2	8	40	4.7	18.3	9.2	1.0	5.1	2.5	5.50 to 8.66	8.67 to 12.00	98.4	11.2 x 3	650	5.9
10	ERM100L-L			6		4.7	18.3	9.2	1.0	5.1	2.5			98.4	11.2 x 4	708	8.1
10	ERM100S-L			12		4.7 x 2	18.3 x 2	9.2 x 2	1.0	5.1	2.5			98.4	11.2 x 4	917	8.1
15	ERM150S-L			8		4.7 x 2	18.3 x 2	9.2 x 2	1.0 x 2	5.1 x 2	2.5 x 2			∞	11.2 x 6	1303	12.1
20	ERM200S-L			6		4.7 x 2	18.3 x 2	9.2 x 2	1.0 x 2	5.1 x 2	2.5 x 2			∞	11.2 x 8	1426	16.1

**SINGLE SPEED HOIST WITH SINGLE SPEED TROLLEY—DIMENSIONS**

Cap. (Tons)	Product Code	Headroom C (in)	b (in)	b' (in)	d (in)	e (in)	e' (in)	g (in)	i (in)	j (in)	k (in)	m (in)	n (in)	r (in)	t (in)
8	ERM080S-L	47.6	19.7	22.9	11.2	20.9	8.8	2.4	6.89	3.5	6.9	10.6	7.5	6.0	2.76
10	ERM100L-L	45.7	19.7	22.9	11.2	20.9	8.8	2.4	6.89	3.1	6.9	10.6	7.5	6.0	2.76
10	ERM100S-L	46.3	19.7	22.9	11.2	20.9	8.8	2.4	6.89	3.1	6.9	10.6	7.5	6.0	2.76
15	ERM150S-L	51.4	40.2	43.4	11.2	20.9	8.8	3.1	6.89	3.3	6.9	10.6	28.0	6.0	2.76
20	ERM200S-L	52.8	40.2	43.4	11.2	20.9	8.8	3.4	6.89	3.1	6.9	10.6	28.0	6.0	2.76

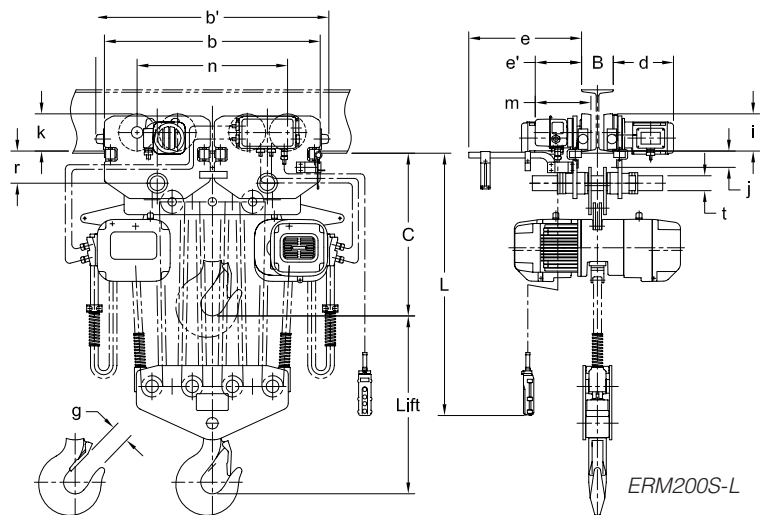
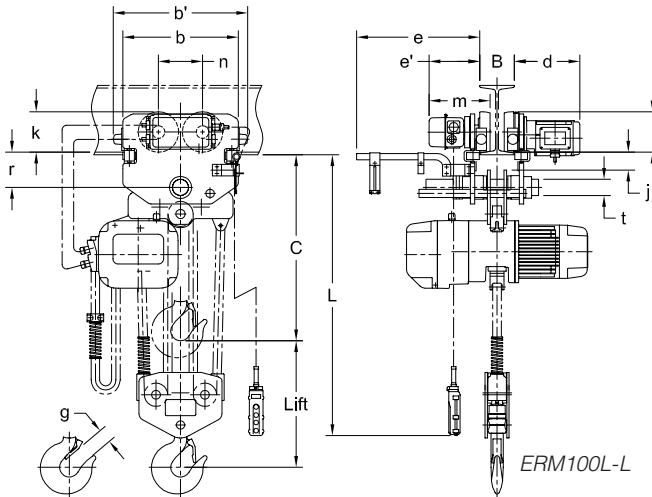

## ERM Large Capacity Electric Chain Hoists With Motorized Trolleys

### DUAL SPEED HOIST WITH SINGLE SPEED TROLLEY—SPECIFICATIONS

Cap. (Tons)	Product Code	Std. Lift (ft)	Push Button Cord L (ft)	Lifting Speed (ft/min)	Traversing Speed (ft/min)	Lifting Motor 3 Phase 60 Hz			Traversing Motor 3 Phase 60 Hz			Flange Width Adjustability B (in)		Min. Allow. Radius for Curve (in)	Load Chain Dia. (mm) x Chain Fall Lines	Net Weight (lbs)	Weight for Additional One Foot of Lift (lbs)
						Output (Hp)	Rated Current (amps)		Output (Hp)	Rated Current (amps)		Std.	Opt.				
							@208-230V	@460V		@208-230V	@460V						
8	ERM080SD-L	10	9.2	8/3	40	4.7/1.6	19.6/9.4	9.8/4.7	1.0	5.1	2.5	5.50 to 8.66	8.67 to 12.00	98.4	11.2 x 3	694	5.9
10	ERM100LD-L			6/2		4.7/1.6	19.6/9.4	9.8/4.7	1.0	5.1	2.5			98.4	11.2 x 4	754	8.1
10	ERM100SD-L			12/4		4.7/1.6 x 2	19.6/9.4 x 2	9.8/4.7 x 2	1.0	5.1	2.5			98.4	11.2 x 4	1021	8.1
15	ERM150SD-L			8/3		4.7/1.6 x 2	19.6/9.4 x 2	9.8/4.7 x 2	1.0 x 2	5.1 x 2	2.5 x 2			∞	11.2 x 6	1402	12.1
20	ERM200SD-L			6/2		4.7/1.6 x 2	19.6/9.4 x 2	9.8/4.7 x 2	1.0 x 2	5.1 x 2	2.5 x 2			∞	11.2 x 8	1526	16.1

### DUAL SPEED HOIST WITH SINGLE SPEED TROLLEY—DIMENSIONS

Cap. (Tons)	Product Code	Headroom C (in)	b (in)	b' (in)	d (in)	e (in)	e' (in)	g (in)	i (in)	j (in)	k (in)	m (in)	n (in)	r (in)	t (in)
8	ERM080SD-L	47.6	19.7	22.9	11.2	20.9	8.8	2.4	6.89	3.5	6.9	10.6	7.5	6.0	2.76
10	ERM100LD-L	45.7	19.7	22.9	11.2	20.9	8.8	2.4	6.89	3.1	6.9	10.6	7.5	6.0	2.76
10	ERM100SD-L	46.3	19.7	22.9	11.2	20.9	8.8	2.4	6.89	3.1	6.9	10.6	7.5	6.0	2.76
15	ERM150SD-L	51.4	40.2	43.4	11.2	20.9	8.8	3.1	6.89	3.3	6.9	10.6	28.0	6.0	2.76
20	ERM200SD-L	52.8	40.2	43.4	11.2	20.9	8.8	3.4	6.89	3.1	6.9	10.6	28.0	6.0	2.76

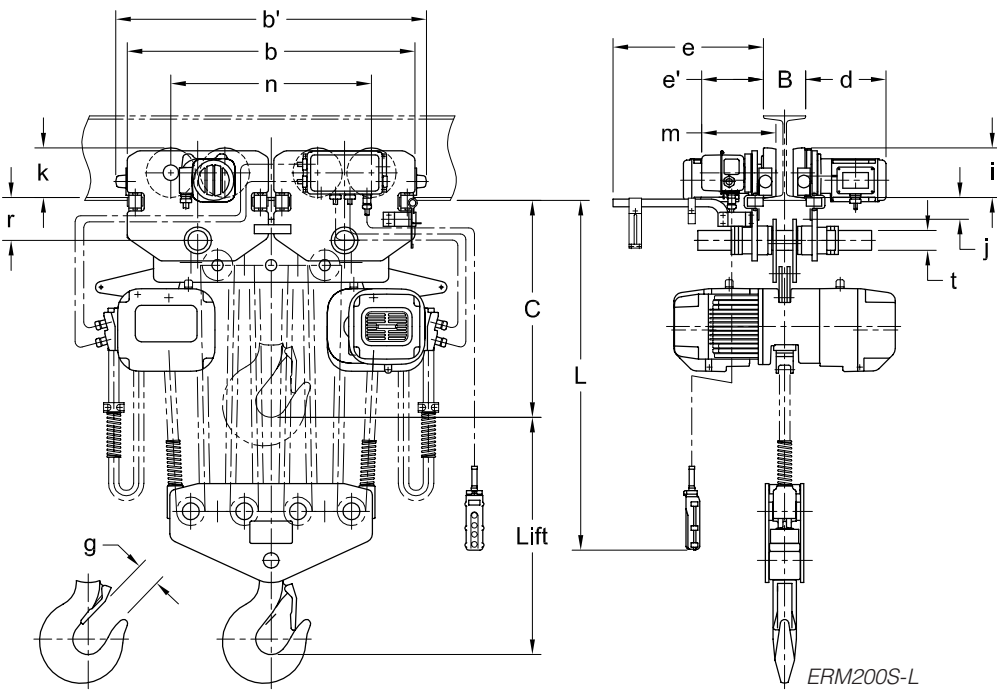
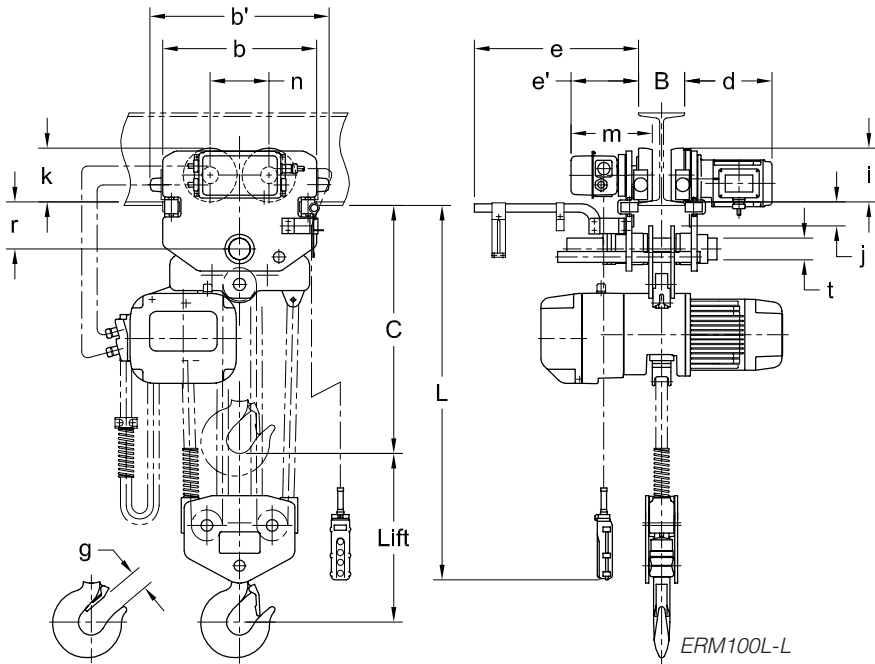

## ERP and ERG Large Capacity Electric Chain Hoists With Push and Geared Trolleys

To manually move our large capacity ER electric chain hoists, the PT push and GT geared trolleys provide smooth travel on precision machined wheels with shielded ball bearings. They are the ideal choice for the one-time unusual job or the seasonal moves for maintenance of heavy equipment.

Refer to pages 4 and 5 for features and benefits and page 26 for standard hoist specifications.

### Standard Manual Trolley Specifications

**Capacity Range**

Push—8 Ton–10 Ton  
Geared—8 Ton–20 Ton

**Shafts**

Standard shafts fit wide flange range  
Longer shafts for wider beams  
Spacers for easy adjustments

**Drop Stops**

Optional

**Bumpers**

Optional

**Standard Hand Chain Drop**

On geared trolleys  
2' less than lift (longer drops available)

**Wheels**

All steel  
Shielded ball bearings  
Fit flat or tapered beam flange



ERP080S  
(Shown with  
optional canvas  
chain container.)

**SINGLE SPEED HOIST WITH PUSH OR GEARED TROLLEY—SPECIFICATIONS**

Cap. (Tons)	Product Code	Std. Lift (ft)	Push Button Cord L (ft)	Lifting Speed (ft/min)	Lifting Motor 3 Phase 60 Hz			Flange Width Adjustability B (in)		Min. Allow. Radius for Curve (in)	Load Chain Dia. (mm) x Chain Fall Lines	Net Weight (lbs)	Weight for Additional One Foot of Lift (lbs)
					Output (Hp)	Rated Current (amps)		Standard	Optional				
						@208-230V	@460V						
8	ERP(ERG)080S	10	9.2	8	4.7	18.3	9.2	5.50 to 8.66	8.67 to 12.00	118.1	11.2 x 3	606 (637)	6.6
10	ERP(ERG)100L			6	4.7	18.3	9.2			118.1	11.2 x 4	666 (697)	8.7
10	ERP(ERG)100S			12	4.7 x 2	18.3 x 2	9.2 x 2			118.1	11.2 x 4	886 (917)	8.7
15	ERG150S			8	4.7 x 2	18.3 x 2	9.2 x 2			∞	11.2 x 6	1303	13.4
20	ERG200S			6	4.7 x 2	18.3 x 2	9.2 x 2			∞	11.2 x 8	1426	17.5

Figures in parentheses are data for geared trolley.

**SINGLE SPEED HOIST WITH PUSH TROLLEY—DIMENSIONS**

Cap. (Tons)	Product Code	Headroom C (in)	a (in)	b (in)	e (in)	e' (in)	g (in)	h (in)	i (in)	j (in)	k (in)	m (in)	n (in)	r (in)	t (in)
8	ERP080S	47.6	4.3	18.9	20.9	1.6	2.4	7.3	6.10	3.5	6.7	3.4	7.7	6.0	2.76
10	ERP100L	45.7	4.3	18.9	20.9	1.6	2.4	7.3	6.10	3.1	6.7	3.4	7.7	6.0	2.76
10	ERP100S	46.3	4.3	18.9	20.9	8.8	2.4	7.3	6.10	3.1	6.7	10.6	7.7	6.0	2.76

**SINGLE SPEED HOIST WITH GEARED TROLLEY—DIMENSIONS**

Cap. (Tons)	Product Code	Headroom C (in)	E (ft)	a (in)	b (in)	e (in)	e' (in)	g (in)	h (in)	i (in)	j (in)	k (in)	k' (in)	m (in)	n (in)	r (in)	t (in)	u (in)
8	ERG080S	47.6	11.4	16.2	18.9	20.9	1.6	2.4	7.3	6.10	3.5	6.7	6.5	3.4	7.7	6.0	2.76	8.4
10	ERG100L	45.7	11.4	16.2	18.9	20.9	1.6	2.4	7.3	6.10	3.1	6.7	6.5	3.4	7.7	6.0	2.76	8.4
10	ERG100S	46.3	11.4	16.2	18.9	20.9	8.8	2.4	7.3	6.10	3.1	6.7	6.5	10.6	7.7	6.0	2.76	8.4
15	ERG150S	51.4	13.4	16.2	39.4	20.9	8.8	3.1	7.3	6.10	3.3	6.7	6.5	10.6	28.2	6.0	2.76	8.4
20	ERG200S	52.8	13.4	16.2	39.4	20.9	8.8	3.4	7.3	6.10	3.1	6.7	6.5	10.6	28.2	6.0	2.76	8.4

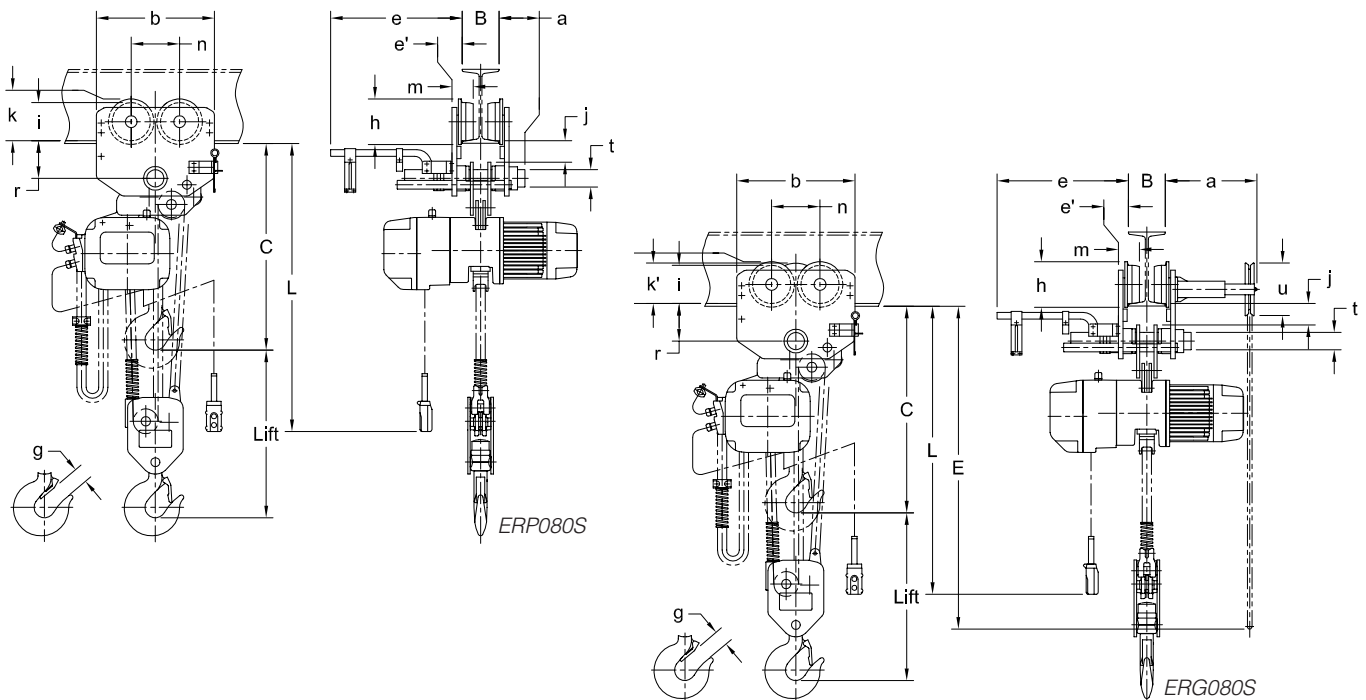

## ERP and ERG Large Capacity Electric Chain Hoists With Push and Geared Trolleys



ERG080S  
(Shown with  
optional canvas  
chain container.)



DUAL SPEED HOIST WITH PUSH OR GEARED TROLLEY—SPECIFICATIONS

Cap. (Tons)	Product Code	Std. Lift (ft)	Push Button Cord L (ft)	Lifting Motor 3 Phase 60 Hz			Flange Width Adjustability B (in)		Min. Allow. Radius for Curve (in)	Load Chain Dia. (mm) x Chain Fall Lines	Net Weight (lbs)	Weight for Additional One Foot of Lift (lbs)	
				Lifting Speed (ft/min)	Output (Hp)	Rated Current (amps)		Std.					Opt.
						@208-230V	@ 460V						
8	ERP(ERG)080SD	10	9.2	8/3	4.7/1.6	19.6/9.4	9.8/4.7	5.50 to 8.66	8.67 to 12.00	118.1	11.2 x 3	650 (681)	6.6
10	ERP(ERG)100LD			6/2	4.7/1.6	19.6/9.4	9.8/4.7			118.1	11.2 x 4	710 (741)	8.7
10	ERP(ERG)100SD			12/4	4.7/1.6 x 2	19.6/9.4 x 2	9.8/4.7 x 2			118.1	11.2 x 4	974 (1005)	8.7
15	ERG150SD			8/3	4.7/1.6 x 2	19.6/9.4 x 2	9.8/4.7 x 2			∞	11.2 x 6	1391	13.4
20	ERG200SD			6/2	4.7/1.6 x 2	19.6/9.4 x 2	9.8/4.7 x 2			∞	11.2 x 8	1515	17.5

Figures in parentheses are data for geared trolley.

DUAL SPEED HOIST WITH PUSH TROLLEY—DIMENSIONS

Cap. (Tons)	Product Code	Headroom C (in)	a (in)	b (in)	e (in)	e' (in)	g (in)	h (in)	i (in)	j (in)	k (in)	m (in)	n (in)	r (in)	t (in)
8	ERP080SD	47.6	4.3	18.9	20.9	1.6	2.4	7.3	6.10	3.5	6.7	3.4	7.7	6.0	2.76
10	ERP100LD	45.7	4.3	18.9	20.9	1.6	2.4	7.3	6.10	3.1	6.7	3.4	7.7	6.0	2.76
10	ERP100SD	46.3	4.3	18.9	20.9	8.8	2.4	7.3	6.10	3.1	6.7	10.6	7.7	6.0	2.76

DUAL SPEED HOIST WITH GEARED TROLLEY—DIMENSIONS

Cap. (Tons)	Product Code	Headroom C (in)	E (ft)	a (in)	b (in)	e (in)	e' (in)	g (in)	h (in)	i (in)	j (in)	k (in)	k' (in)	m (in)	n (in)	r (in)	t (in)	u (in)
8	ERG080SD	47.6	11.4	16.2	18.9	20.9	1.6	2.4	7.3	6.10	3.5	6.7	6.5	3.4	7.7	6.0	2.76	8.4
10	ERG100LD	45.7	11.4	16.2	18.9	20.9	1.6	2.4	7.3	6.10	3.1	6.7	6.5	3.4	7.7	6.0	2.76	8.4
10	ERG100SD	46.3	11.4	16.2	18.9	20.9	8.8	2.4	7.3	6.10	3.1	6.7	6.5	10.6	7.7	6.0	2.76	8.4
15	ERG150SD	51.4	13.4	16.2	39.4	20.9	8.8	3.1	7.3	6.10	3.3	6.7	6.5	10.6	28.2	6.0	2.76	8.4
20	ERG200SD	52.8	13.4	16.2	39.4	20.9	8.8	3.4	7.3	6.10	3.1	6.7	6.5	10.6	28.2	6.0	2.76	8.4

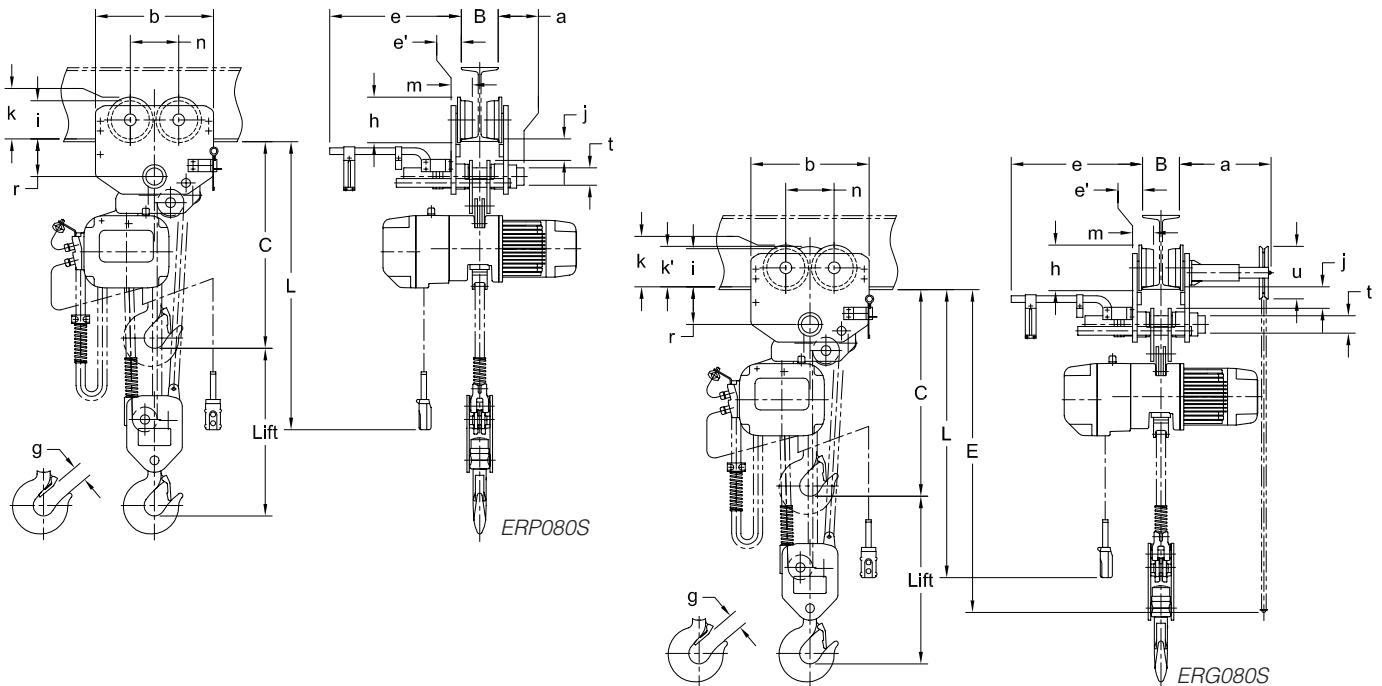

## Options and Technical Data

### VFD PACKAGES

Harrington's standard variable frequency drive packages for ER hoists include:

- VFD installed in a NEMA 12/13 electrical enclosure
- VFD programmed & tested to customer's specs for speed(s) and/or acceleration
- Branch circuit fuses to protect the VFD and the hoist motor
- Mounting bracket for VFD enclosure
- Wiring and hardware

### LOAD LIMITER

Reduces the potential for making hazardous, over-capacity lifts. The load limiter is preset at 115% of rated capacity and protects the hoist mechanism from damage due to overloading. Overloading the hoist electrically activates the load limiter, making the hoist inoperable (load can still be lowered at any time).



### CORROSION-RESISTANT CHAINS

These special premium chains give the advantage of increased resistance to corrosion. Ideal for job sites affected by rain, saltwater, steam and chemicals.

Both NP (Nickel Plated) and ND (Nickel Diffused) load chains offer superior resistance to corrosive conditions.

Corrosion Resistance Test Results for NP and ND Chains			
Substance		Concentration %	Resistance to Corrosion
Inorganic Acids	Sulfuric Acid	10	Some
	Nitric Acid	10	Some
	Hydrochloric Acid	10	Some
	Phosphoric Acid	10	Slight
	Boric Acid	5	Slight
Organic Acids	Acetic Acid	10	Slight
	Tartaric Acid	10	No
Alkalis	Caustic Soda	10	No
	Ammonia Hydroxide	10	Slight
Others	Air-Indoor/Outdoor	—	No
	Seawater	—	Slight
	Seasonings	—	No

*Results listed in this table are for chemicals in a pure state. The degree of corrosion resistance may differ from this table with the presence of other chemicals, different concentrations, mixed substances or damage to the nickel surface layer.*

### UNIVERSAL LATCH KITS

Generic design to fit most hooks. Available in standard steel or stainless steel. Neck and throat dimensions can be combined for proper fit. (Example, neck size E with throat size L.) Neck measurement must be diameter—not circumference. Latch kit brochures available upon request. Contact Customer Service for dimensions not shown.

Latch Kit Product Code	Neck Diameter N (in)	Throat Opening T (in)
A	9/16 to 5/8	1 1/16 to 1 1/8
B	3/4 to 13/16	1 1/4
C	7/8 to 1	1 3/8 to 1 1/2
D	1 1/8 to 1 1/4	1 3/4 to 1 7/8
E	1 1/2 to 1 1/2	2 1/16
F	1 5/8 to 1 11/16	2 1/4
G	1 3/4 to 1 13/16	2 1/2
H	1 7/8 to 2	3
J	2 1/16 to 2 1/8	3 3/8
K	2 3/16 to 2 1/4	3 1/2
L	2 5/16 to 2 3/8	3 3/4
M	2 7/16 to 2 3/4	4
O	3 to 3 1/4	4 1/2

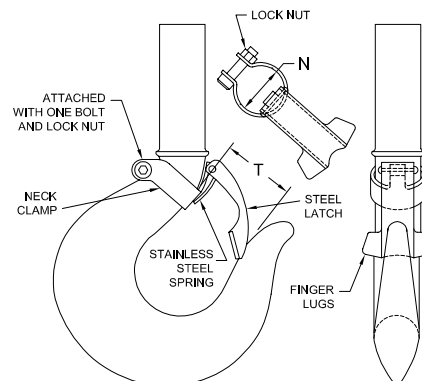

**(N)ER CHAIN DIMENSIONS**

Cap. (Tons)	Product Code	d (in)	a (in)	b (in)	P (in)
1/8	(N)ER001HCC(D)	0.20	0.25	0.71	0.59
1/8	(N)ER001H(D)	0.20	0.25	0.71	0.59
1/4	(N)ER003S(D)	0.20	0.25	0.71	0.59
1/4	(N)ER003SCC(D)	0.20	0.25	0.71	0.59
1/4	(N)ER003H(D)	0.25	0.31	0.87	0.75
1/2	(N)ER005L(D)	0.25	0.31	0.87	0.75
1/2	(N)ER005S(D)	0.25	0.31	0.87	0.75
1	(N)ER010L(D)	0.31	0.39	1.10	0.94
1	NER010M	0.31	0.39	1.10	0.94
1	(N)ER010S(D)	0.31	0.39	1.10	0.94
1 1/2	(N)ER015S(D)	0.39	0.49	1.38	1.18
2	(N)ER020L(D)	0.39	0.49	1.38	1.18
2	NER020M	0.39	0.49	1.38	1.18
2	(N)ER020S(D)	0.39	0.49	1.38	1.18
2 1/2	(N)ER025S(D)	0.44	0.55	1.54	1.34
3	NER030C	0.39	0.49	1.38	1.18
3	(N)ER030L(D)	0.49	0.62	1.73	1.50
3	(N)ER030S(D)	0.49	0.62	1.73	1.50
5	(N)ER050L(D)	0.44	0.55	1.54	1.34
8	(N)ER080S(D)	0.44	0.55	1.54	1.34
10	(N)ER100L(D)	0.44	0.55	1.54	1.34
10	(N)ER100S(D)	0.44	0.55	1.54	1.34
15	(N)ER150S(D)	0.44	0.55	1.54	1.34
20	(N)ER200S(D)	0.44	0.55	1.54	1.34

**SNER CHAIN DIMENSIONS**

Cap. (Tons)	Product Code	d (in)	a (in)	b (in)	P (in)
1/4	SNER003S	0.20	0.25	0.71	0.59
1/2	SNER005L	0.25	0.31	0.87	0.75
1/2	SNER005S	0.25	0.31	0.87	0.75
1	SNER010L	0.31	0.39	1.10	0.94
1	SNER010S	0.31	0.39	1.10	0.94
2	SNER020L	0.39	0.49	1.38	1.18
3	SNER030C	0.39	0.49	1.38	1.18

**ED CHAIN DIMENSIONS**

Cap. (lbs)	Product Code	d (in)	a (in)	b (in)	P (in)
125 to 1050	(All Models)	0.16	0.20	0.53	0.48

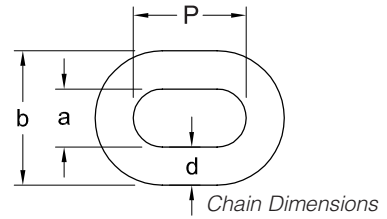

**(N)ER\* HOOK DIMENSIONS**

Capacity Code	Hook**	a (in)	b (in)	c (in)	d (in)	e (in)	f (in)	g (in)	h (in)
001H, 003S, 003H, 005L, 005S	T	1.1	0.7	0.9	0.7	1.4	1.5	1.1	3.5
	B	1.1	0.7	0.9	0.7	1.4	1.5	0.9	3.4
001HCC, 003SCC	T	1.1	0.7	0.9	0.7	1.4	1.5	1.1	3.5
	B	0.8	0.5	0.7	0.5	1.4	1.4	1.0	3.0
010L, 010M, 010S	T & B	1.4	0.9	1.2	0.9	1.7	1.8	1.2	4.2
015S	T	1.9	1.1	1.6	1.1	2.0	2.2	1.5	5.3
	B	1.7	1.0	1.4	1.0	1.9	2.0	1.3	4.9
020S, 020M, 020L	T & B	1.9	1.1	1.6	1.1	2.0	2.2	1.5	5.3
025S	T	2.2	1.4	1.9	1.4	2.4	2.5	1.7	6.2
	B	2.0	1.2	1.7	1.2	2.1	2.3	1.6	5.7
030C, 030L, 030S	T & B	2.2	1.4	1.9	1.4	2.4	2.5	1.7	6.3
050L	T & B	2.6	1.7	2.2	1.7	2.5	2.9	1.8	7.4
080S	B	3.3	2.2	2.9	1.9	3.3	3.6	2.4	9.5
100L, 100S	T & B	3.3	2.2	2.9	1.9	3.3	3.6	2.4	9.5
150S	T & B	4.1	2.8	3.4	2.4	3.9	4.3	3.1	11.4
200S	T & B	4.6	3.3	3.9	2.8	4.3	4.9	3.4	12.3

\*NER Available through 5 Ton.  
\*\*T=top hook, B=bottom hook.

**SNER\* HOOK DIMENSIONS**

Capacity Code	Hook*	a (in)	b (in)	c (in)	d (in)	e (in)	f (in)	g (in)	h (in)
003, 005L, 005S	T	1.1	0.7	0.9	0.7	1.4	1.5	1.1	3.5
	B	1.1	0.7	0.9	0.7	1.4	1.5	0.9	3.4
010L, 010S	T & B	1.4	0.9	1.2	0.9	1.7	1.8	1.2	4.2
020L	T & B	1.9	1.1	1.6	1.1	2.0	2.2	1.5	5.3
030C	T & B	2.2	1.4	1.9	1.4	2.4	2.5	1.7	6.3

\*T=top hook, B=bottom hook.

**ED HOOK DIMENSIONS**

Capacity Code	Hook*	a (in)	b (in)	c (in)	d (in)	e (in)	f (in)	g (in)	h (in)
125 - 525	T	0.8	0.3	0.7	0.3	1.3	1.2	1.0	2.9
	B	0.8	0.5	0.7	0.5	1.4	1.4	1.0	3.0
1050	T	1.1	0.7	0.9	0.7	1.4	1.2	1.1	3.5
	B	1.1	0.7	0.9	0.7	1.4	1.4	0.9	3.4

\*T=top hook, B=bottom hook.

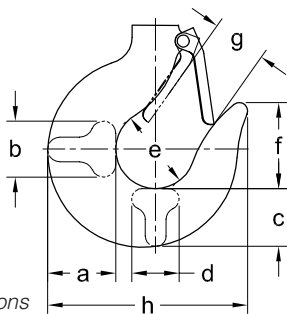

## Options and Technical Data

### DUTY CLASSIFICATIONS

Hoist Duty Class	Typical Areas of Application	Operation Time Ratings at K=0.65*			
		Uniformly Distributed Work Periods		Infrequent Work Periods	
		Max. ON Time (min/hr)	Max. No. of Starts/hr	Max. ON Time From Cold Start (min)	Max. No. of Starts
H2	Light machine shop fabricating, service and maintenance; loads and utilization randomly distributed; rated loads infrequently handled	7.5 (12.5%)	75	15	100
H3	General machine shop fabricating, assembly, storage, and warehousing; loads and utilization randomly distributed	15 (25%)	150	30	200
H4	High volume handling in steel warehouses, machine shops, fabricating plants and mills, and foundries; manual or automatic cycling operations in heat treating and plating; loads at or near rated load frequently handled	30 (50%)	300	30	300

\*K=Mean effective load factor.

### LIFTING MOTOR RATINGS

#### Short Time Rating

This rating indicates how long the hoist can be operated continuously at the rated capacity on the cycle below, assuming continued operation for a short time span.

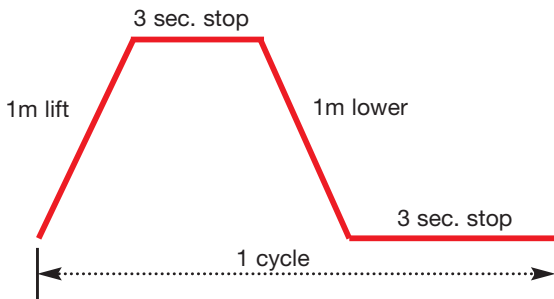

- Single speed: 60 min
- Dual speed: 30/10 min

#### Intermittent Rating (Percent ED)

##### Max. Number of Starts Per Hour

This rating indicates the allowable ratio of motor ON time to motor OFF time, and starts per hour for a hoist operated continuously at 63% of rated capacity on the cycle below, assuming continued operation or repeated starting over a long time span.

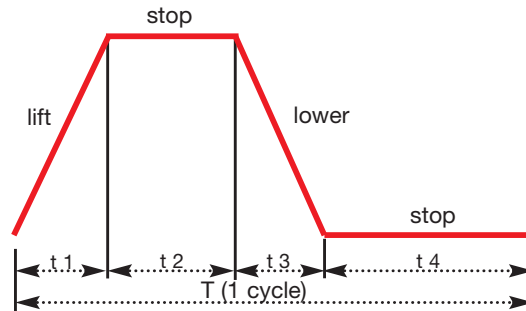

$$\text{Example (single speed): \%ED} = \frac{\text{Motor ON time (t1 + t3)} \times 100}{T (1 \text{ cycle})}$$

(Where T = 1 cycle (t1 + t2 + t3 + t4) and is not more than 10 minutes.)

##### NER/ER Lifting Motor Ratings

- Single speed: 60% ED, 360 starts/hr
- Dual speed: 40/20% ED, 120/240 starts/hr

### BULLARD® AND SHUR-LOC® HOOKS

These hooks offer a positive locking latch feature. Consult Customer Service for full details.

**COMPLIANCE**

Harrington’s electric chain hoists are produced to comply with:

- ANSI/NFPA 70, “National Electrical Code”
- ANSI/ASME B30.16, “Safety Standard—Overhead Hoists (Underhung)”
- ANSI/ASME HST—1M, “Performance Standard for Electric Chain Hoists”

Harrington’s manual and electric-powered trolleys are produced to comply with the trolley-related requirements of:

- OSHA Section 1910.179 of Title 29, “Occupational Safety and Health Regulations — Overhead and Gantry Cranes”
- ANSI/ASME B30.11, “Safety Standard—Monorails and Underhung Cranes”
- ANSI/ASME B30.17, “Safety Standard—Overhead and Gantry Cranes (Top Running Bridge, Single Girder, Underhung Hoist)”

**Product Code  
For NER/ER Series**

**ERM 020 SD-SD**

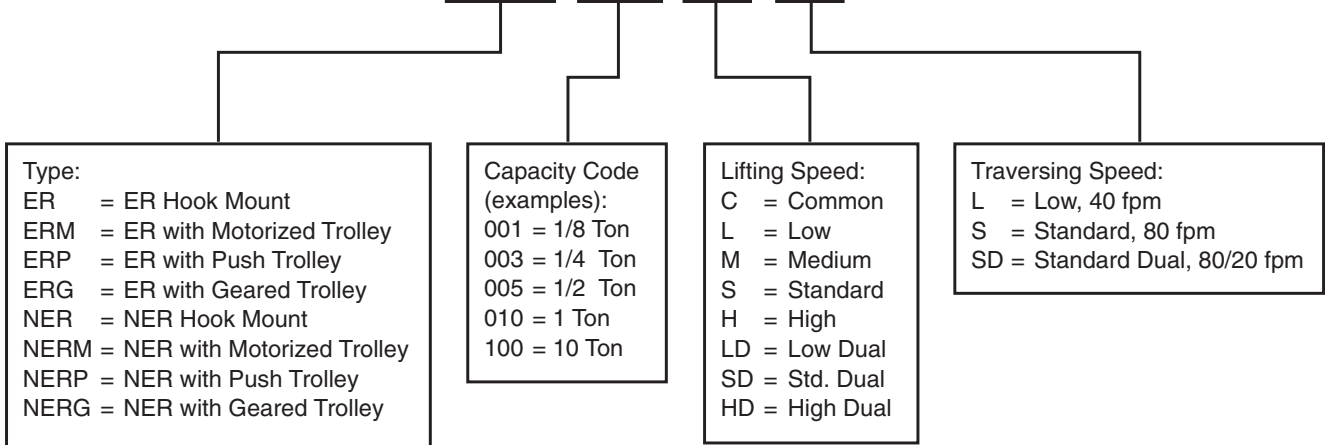

## Notes



## Complete Product Offering

Over the years Harrington has continued to respond to the needs of our customers by further expanding our product offerings. In addition to the many models described in this catalog, our full series of product catalogs, as shown below, will provide you with all of the information you will need to answer questions, specify a product and place an order. For catalog copies or answers to specific product questions, please contact our Customer Service Department by calling 800-233-3010 (Manheim, PA) or 800-317-7111 (Corona, CA) or e-mail [customerservice@harringtonhoists.com](mailto:customerservice@harringtonhoists.com)

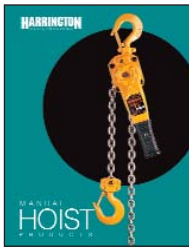

### Manual Hoist Products Catalog:

Refer to this Harrington catalog for detailed information on the following:

- Lever hoists
- Hand chain hoists
- Hoist and trolley combinations
- Low headroom trolley hoists
- Push and geared trolleys
- Hoist load testers

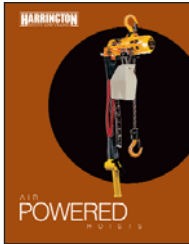

### Air Powered Hoists Catalog:

Refer to this Harrington catalog for detailed information on the following:

- Compact Mini-Cat with pendant, cord and manipulator controls
- Air hoists with pendant and cord controls
- Air trolleys

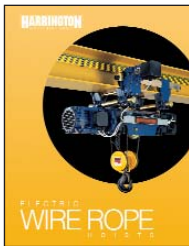

### Electric Wire Rope Hoists Catalog:

Refer to this Harrington catalog for detailed information on the following:

- Deck/base mounted or lug suspended hoists
- Standard headroom trolley hoists
- Ultra-low headroom trolley hoists



### Crane Components Catalog:

Refer to this Harrington catalog for detailed information on the following:

- End trucks-top running-motorized, geared and push
- End trucks-underhung-motorized, geared and push
- Double girder MAX-E-Lift end trucks
- Convertible push end trucks
- Beam accessory kits

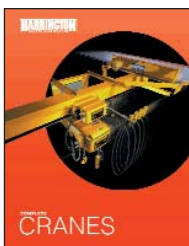

### Complete Cranes Catalog:

Refer to this Harrington catalog for detailed information on the following:

- Heavy duty Class C single girder top running and underhung cranes
- Heavy duty Class C double girder top running and underhung cranes
- Medium duty top running and underhung push cranes
- Crane control panels

**CONTACT YOUR NEARBY  
HARRINGTON DISTRIBUTOR**

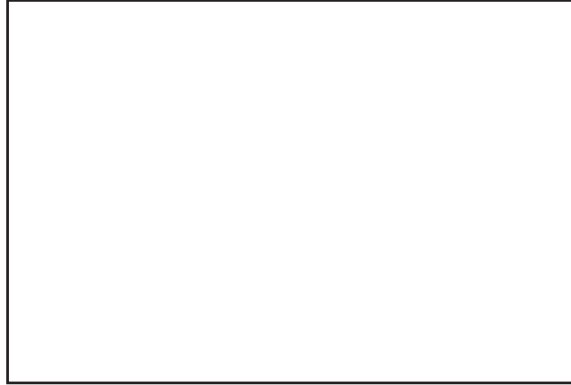

## Warranty

All products sold by Harrington Hoists, Inc. are warranted to be free from defects in material and workmanship from date of shipment by Harrington for the following periods:

**Manual Hoists & Trolleys—2 years**

**Electric Hoists, Air Hoists & Trolleys, Crane Components—1 year**

**Spare / Replacement Parts—1 year**

The product must be used in accordance with manufacturer's recommendations and must not have been subject to abuse, lack of maintenance, misuse, negligence, or unauthorized repairs or alterations.

Should any defect in material or workmanship occur during the above time period in any product, as determined by Harrington Hoists' inspection of the product, Harrington Hoists, Inc. agrees, at its discretion, either to replace (not including installation) or repair the part or product free of charge and deliver said item F.O.B. Harrington Hoists, Inc. place of business to customer.

Customer must obtain a Return Goods Authorization as directed by Harrington or Harrington's published repair center prior to shipping product for warranty evaluation. An explanation of the complaint must accompany the product. Product must be returned freight prepaid. Upon repair, the product will be covered for the remainder of the original warranty period. If it is determined there is no defect, or that the defect resulted from causes not within the scope of Harrington's warranty, the customer will be responsible for the costs of returning the product.

Harrington Hoists, Inc. disclaims any and all other warranties of any kind expressed or implied as to the product's merchantability or fitness for a particular application. Harrington will not be liable for death, injury to persons or property, or for incidental, contingent, special or consequential damages, loss or expense arising in connection with the use or inability whatever, regardless of whether damage, loss, or expense results from any act or failure to act by Harrington, whether negligent or willful, or from any other reason.



[www.harringtonhoists.com](http://www.harringtonhoists.com)

Harrington Hoists, Inc.  
401 West End Ave., Manheim, PA 17545  
**717-665-2000 / 800-233-3010**  
Fax: 717-665-2861

Harrington Hoists, Inc.—Western Division  
2341 Pomona Rincon Rd., No. 103, Corona, CA 92880-6973  
**951-279-7100 / 800-317-7111**  
Fax: 951-279-7500

