

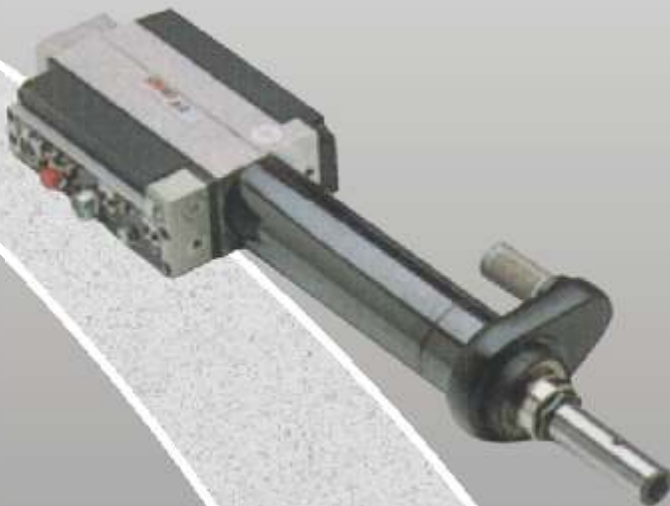

Auto Feed Drills & Tappers

 Chicago
Pneumatic™



AFD Features

Desoutter Auto Feed Drill and Tapper Features

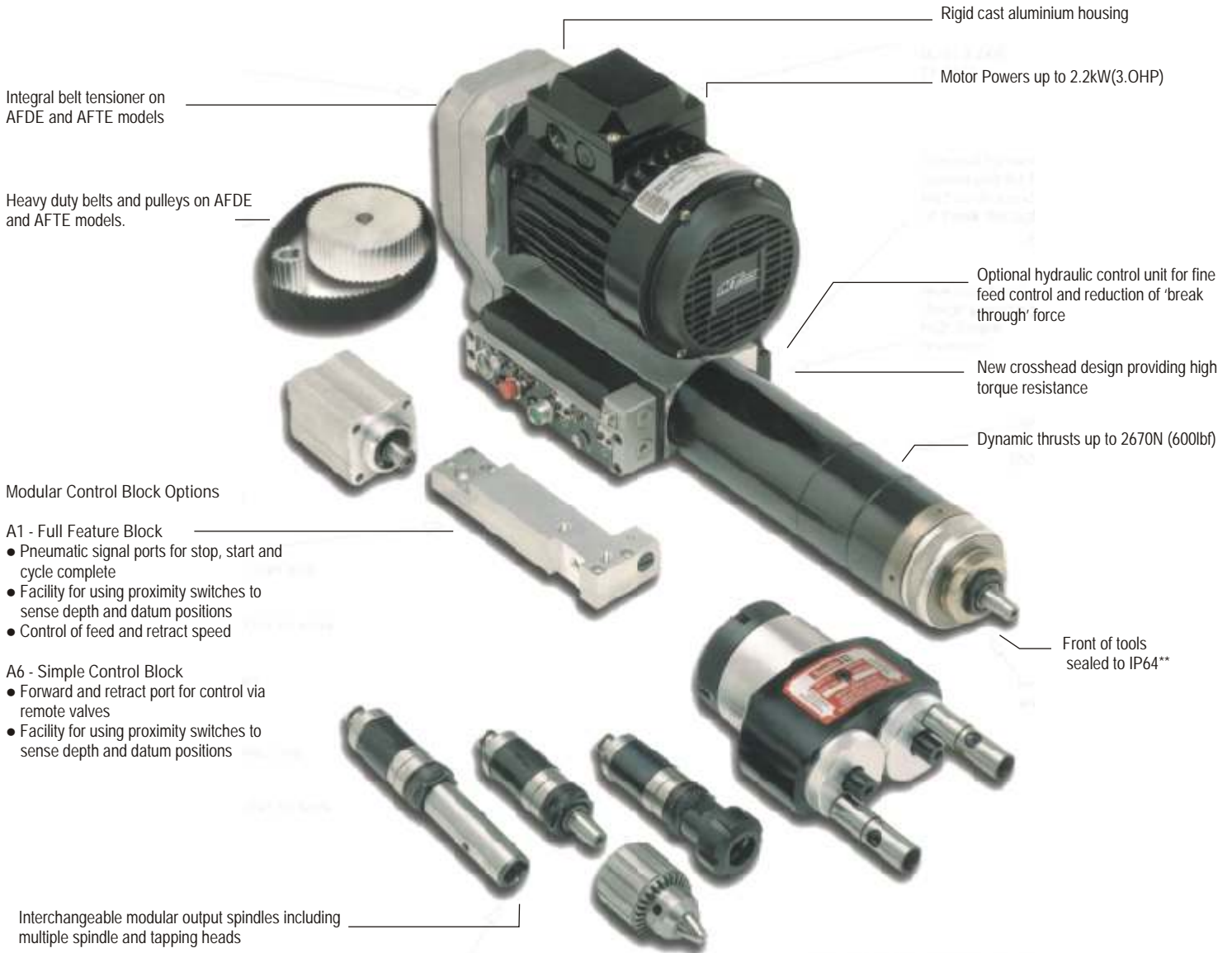

General Information

- All performance data is obtained at a line pressure of 6.3±0.15 bar in accordance with ISO2787 (1984).
- All speeds are nominal.
- Performance data is subject to alteration without prior notice.
- Unless stated otherwise dimensions are in mm.
- All imperial dimensions and performance data have been calculated from the measured metric values.
- Sound levels are ±2dB(A) measured using CAGI-PNEUROP test code.
- Before using an AFD always refer to the operating and warning instructions supplied with the tool.
- For AFD models maximum power is achieved at 50% of no load speed.

- Modular components for flexibility of speed and function
- Simple interfaces for communicating to other equipment
- Control options including peck feed, dwell and skip feed

** AFD415, AFDE400/410 and AFDE600/610/620 tools only

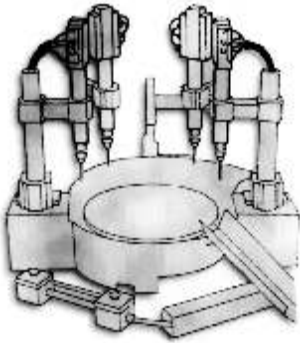

Ease of Incorporation into Machine or Process

- Extensive range of mounting clamps
- Control interfaces to link AFD(E) to other equipment through pneumatics or electrically
- Single signal required for AFD(E) to perform cycle
- Output signals at datum and depth
- Electric motor mounting on 200, 400 and 600 series can be rotated through 180°

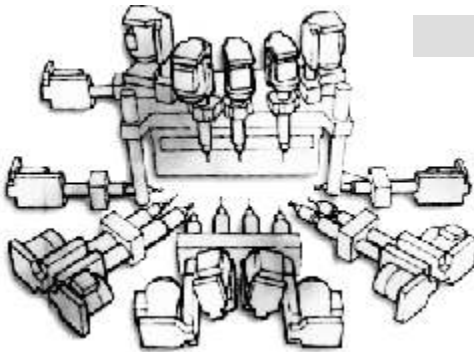

Modular Design

- Flexibility of unit function and speed
- Common components in differing models reducing inventory
- Multiple spindle head options
- Drill and tapping options for all models

Model Codes

Model Type	
Pneumatic Feed and Drive	
AFD205, AFD215	0.22kW (0.29HP)
AFD415	0.38kW (0.50HP)
AFD/AFT60	0.52kW (0.70HP)

Pneumatic Feed, Electric Drive	
AFDE200	0.25kW (0.33HP)
AFDE400, AFDE600	0.33kW (0.40HP)
AFDE410, AFDE610	0.75kW (1.00HP)
AFDE620	1.10kW (1.50HP)
AFDE700	1.50kW (2.00HP)
AFDE710	2.20kW (3.00HP)

Electric Feed and Drive via Leadscrew	
AFTE270	0.18kW (0.24HP)
AFTE470	0.38kW (0.50HP)
AFTE480	0.75kW (1.00HP)

No Load Speed
The free output speed of the drill or taper with no drilling or tapping load applied.

Control Block	
A1 - Full feature type*	- Automatic cycle
A6 - Simple type**	- Remote cycle control
A7 - Leadscrew type	- PNP
A8 - Leadscrew type	- NPN

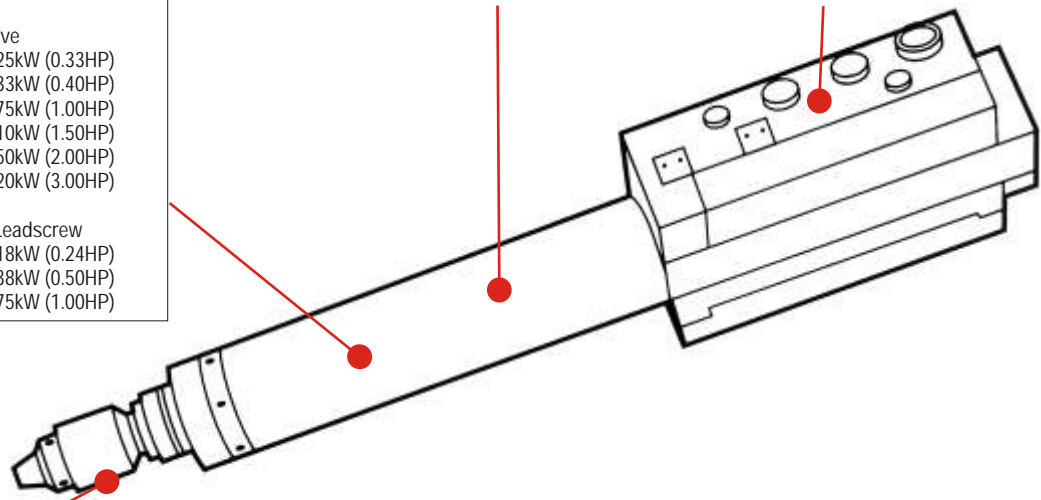

Output Spindle**
Output spindle to be supplied.

* Not required on AFTE models.
** Does not apply for AFD60 and AFT60.

How to Order

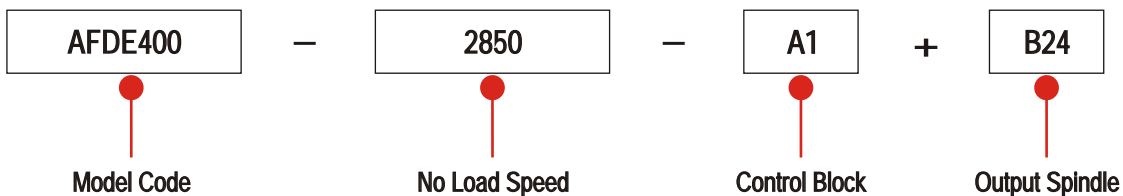

What is an AFD?



The Desoutter range of Auto Feed Drills and Tappers are fixture mounted tools combining linear feed and rotation for machining and tapping operations.

There are 3 basic model types:

- AFD/AFT – Pneumatic Feed and Drive
- AFDE – Pneumatic Feed with Electric Drive
- AFTE – Electric Drive and Feed via a Leadscrew

A wide range of accessories allow the tools to be configured to suit the application and include mounting clamps, output spindles, multiple spindle heads and various control options for interfacing with PLC's or pneumatics.

Drilling Pneumatic Drive

AFD205/ AFD215 pneumatic drive



- Options of compact AFD205 or long stroke AFD215
- High thrust / size ratio
- Capacity up to 5mm (3/16") in aluminium
- Modular output spindles

SPEED 650, 1000, 2700, 4350, 10000, 18700

TOOL TYPE	POWER HP	THRUST N	STROKE mm	WEIGHT kg
AFD205	0.30	400	50	3.9
AFD215	0.30	400	90	4.2

AFD415 pneumatic drive



- Compact unit design
- Long working stroke of 100mm (3.94")
- Spindle sealed to IP64 standard
- Capacity up to 8mm (5/16") in mild steel, 10mm (3/8") in aluminium
- Modular output spindles

SPEED 490, 790, 1250, 2100, 3400, 5400, 7000, 18000

TOOL TYPE	POWER HP	THRUST N	STROKE mm	WEIGHT kg
AFD415	0.51	706	100	6.2

AFD60 pneumatic drive



- Heavy duty pneumatic unit
- Chuck supplied fitted to tool, 10mm (3/8") for 1600-4300rpm and 13mm (1 / 2") for 550-1000rpm
- Full feature control block fitted as standard
- Capacity up to 16mm (5/ 8") in aluminium, 12mm(1/2") in mild steel

SPEED 550, 700, 1000, 1600, 2100, 3000, 4300

TOOL TYPE	POWER HP	THRUST N	STROKE mm	WEIGHT kg
AFD60	0.70	1200	95	8.1

Drilling Electric Drive

AFDE200 electric drive



- Compact unit size
- High speed options up to 22400 rpm @ 50Hz, 26900 rpm @ 60Hz with K42 output
- Capacity up to 5mm (3/16") in aluminium
- Modular output spindles

SPEED 850, 1200, 2350, 2850, 3750, 4600, 5250, 8000, 10000

TOOL TYPE	POWER	THRUST	STROKE	WEIGHT
	HP	N	mm	kg
AFDE200	0.34	320	90	10.1

AFDE400/ AFDE410 electric drive



- Comprehensive speed range 330-10000 rpm @ 50Hz, 400-11900 rpm @ 60Hz
- 0.33kW (0.44HP) and 0.75kW (1.00HP) options
- Capacity up to 10mm (3/8") in aluminium or 8mm (5/16") in mild steel
- Spindle sealed to IP64 standard
- Modular output spindles

SPEED 330, 550, 900, 1200, 1450, 1750, 2350, 2850, 3750, 4600, 5250, 8000, 10000

TOOL TYPE	POWER	THRUST	STROKE	WEIGHT
	HP	N	mm	kg
AFDE400	0.44	724	100	11.4

SPEED 330, 550, 900, 1200, 1450, 1750, 2350, 2850, 3750, 4600, 5250, 8000

AFDE410	1.00	724	100	12.4
---------	------	-----	-----	------

AFDE600/ AFDE610/ AFDE620 electric drive



- 3 power ratings to give optimum power / thrust combination
- Heavy duty belts and pulley drive with integral belt tensioner
- Capacity up to 12mm (1/2") in mild steel
- Spindle sealed to IP64 standard
- Modular output spindles

SPEED 330, 550, 900, 1200, 1450, 1750, 2350, 2850, 3750, 4600, 5250

TOOL TYPE	POWER	THRUST	STROKE	WEIGHT
	HP	N	mm	kg
AFDE600	0.44	1557	100	17.4
AFDE610	1.00	1557	100	18.4
AFDE620	1.47	1557	100	22

AFDE700/ AFDE710 electric drive



- Heavy duty drill unit
- Base mounted with cross key location
- Compact design
- Capacity up to 20mm (3/4") in mild steel
- Hydraulic feed option available upon request to provide up to 7400N (1660 lbf) of thrust

SPEED 140, 280, 460, 950, 1400, 1900, 2850, 4750

TOOL TYPE	POWER	THRUST	STROKE	WEIGHT
	HP	N	mm	kg
AFDE700	2.00	2670	127	63
AFDE710	2.95	2670	127	63

Tapping Electric Drive — AFDE tappers



- Comprehensive range of tapping tools
- Tapping gearboxes feature push-pull drive which automatically reverses when the tool returns (except AFDE700)
- Capacity up to 22mm (3/4") in aluminium, 16mm (5/8") in mild steel
tapping electric drive with pneumatic feed – push-pull

TOOL TYPE	SPEED	POWER	TORQUE	STROKE	WEIGHT
	r p m	HP	N m	m m	k g
AFDE200-850	850	0.34	2.4	90	11.1
AFDE200-1200	1200	0.34	1.8	90	11.1
AFDE400-330	330	0.44	8.6	100	12.8
AFDE400-550	550	0.44	5.2	100	12.8
AFDE400-900	900	0.44	3.2	100	12.8
AFDE400-1200	1200	0.44	2.4	100	12.8
AFDE410-330	330	1.00	19.6	100	13.8
AFDE410-550	550	1.00	11.8	100	13.8
AFDE410-900	900	1.00	7.2	100	13.8
AFDE410-1200	1200	1.00	5.4	100	13.8
AFDE600-330	330	0.44	8.6	100	20.1
AFDE600-550	550	0.44	5.2	100	20.1
AFDE600-900	900	0.44	3.2	100	20.1
AFDE600-1200	1200	0.44	2.4	100	20.1
AFDE610-330	330	1.00	19.6	100	21.1
AFDE610-550	550	1.00	11.8	100	21.1
AFDE610-900	900	1.00	7.2	100	21.1
AFDE610-1200	1200	1.00	5.4	100	21.1
AFDE700-140	140	2.00	92	127	63
AFDE700-280	280	2.00	46	127	63
AFDE700-460	460	2.00	28	127	63
AFDE700-950	950	2.00	13.6	127	63

The following tools require suitable output spindles to fit a tapping head:

TOOL TYPE	OUTPUT SPINDLE
AFDE200	K32
AFDE600	B24
AFDE610	B24

How to order

Examples:

AFDE200 - 850 - A1 + K32 + 357193(H21)

AFDE400 - 550 - A1 + B7

AFDE610 - 900 - A1 + B24 + 383813(J19)

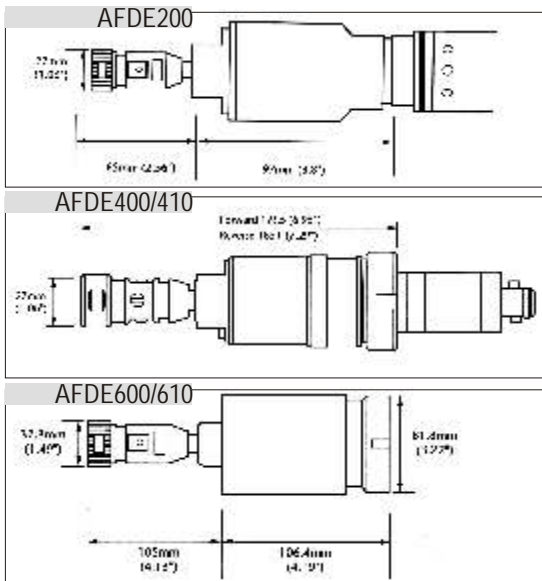

Tapping Pneumatic Drive — AFD / AFT tappers



- Compact tapping units
- Tapping gearboxes feature push-pull drive which automatically reverses when the tool returns
- Capacity up to 12mm (1/2") in aluminium, 8mm (5/16") in mild steel
tapping pneumatic drive and feed – push-pull

TOOL TYPE	SPEED	POWER	TORQUE	STROKE	WEIGHT
	r p m	HP	N m	m m	k g
AFD205-650	650	0.30	4.3	50	4.5
AFD205-1000	1000	0.30	2.8	50	4.5
AFD215-650	650	0.30	4.3	90	4.8
AFD215-1000	1000	0.30	2.8	90	4.8
AFD415-490	490	0.51	9.9	100	6.6
AFD415-790	790	0.51	6.1	100	6.6
AFD415-1250	1250	0.51	3.9	100	6.6
AFT60-550	550	0.70	12.1	95	11.9
AFT60-700	700	0.70	9.5	95	11.9

The following tools require suitable output spindles to fit a tapping head:

TOOL TYPE	OUTPUT SPINDLE
AFD205	K32
AFD215	K32

How to order

Examples:

AFD205 - 650 - A1 + K32 + 357193(H21)

AFD215 - 1000 - A6 + K32 + 357193(H21)

AFD415 - 790 - A1 + B7

AFT60 - 700

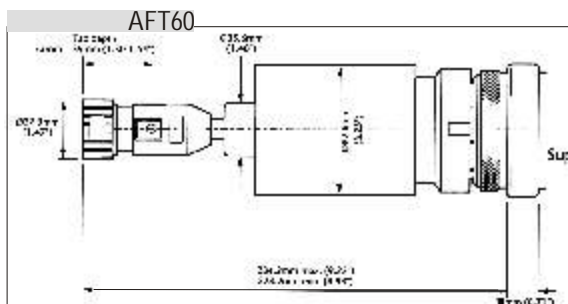
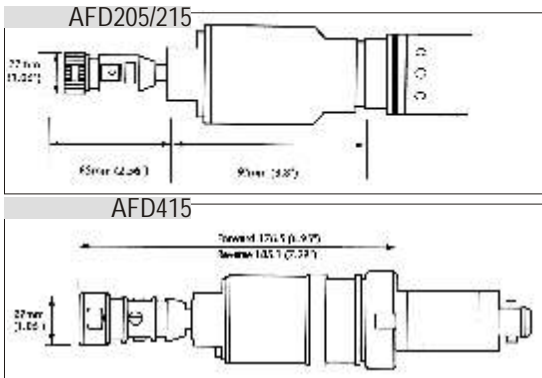

Tapping Leadscrew

AFTE270 leadscrew

- Light duty high speed leadscrew tappers
- Features 0.18kW (0.24HP) brake motor
- Supplied fitted with proximity switches for depth, datum and 'no hole' sensing, PNP or NPN
- Quick release interchangeable leadscrew and nut assembly
- Capacity up to 6mm (1/4") in aluminium, 3mm (1/8") in mild steel depending on thread form



Quick release
Leadscrew and
Nut Assembly

TOOL TYPE	SPEED	POWER	TORQUE	STROKE	WEIGHT
	r p m	HP	N m	mm	kg
AFTE270-1100	1100	0.24	1.4	60	12
AFTE270-1300	1300	0.24	1.1	60	12
AFTE270-1850	1850	0.24	0.9	60	12
AFTE270-2350	2350	0.24	0.7	60	12
AFTE270-2950	2950	0.24	0.6	60	12

leadscrew / nut assemblies AFTE270

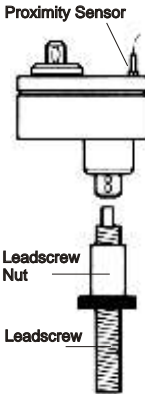
SHAPE	REPLACEMENT LEADSCREW/ NUT ONLY	ORDERING CODE	THREAD SIZE/ PITCH	REPLACEMENT LEADSCREW/ NUT ONLY	ORDERING CODE	THREAD SIZE/ PITCH
	part no.			part no.		
	380373	L34	0.25	350993	L22	1/8" NPT(27 TPI)
	369933	L33	0.30	350923	L23	0 BA
	369923	L32	0.35	350933	L24	1 BA
	359303	L31	0.40	350943	L25	2 BA
	359293	L30	0.45	350953	L26	3 BA
	350713	L1	0.50	350963	L27	4 BA
	350723	L2	0.60	350973	L28	5 BA
	350733	L3	0.70	350983	L29	6 BA
	350743	L4	0.75			
	350753	L5	0.80			
	350763	L6	1.00			
	402723	L38	80 TPI			
	391533	L36	64 TPI			
	391543	L37	56 TPI			
	390333	L35	48 TPI			
350803	L10	40 TPI				
350813	L11	36 TPI				
350823	L12	32 TPI				
350833	L13	28 TPI				
350843	L14	26 TPI				
350853	L15	24 TPI				

Proximity switches
included with tool.

Control Blocks
A7 – PNP Switches
A8 – NPN Switches

AFTE470 / AFTE480 leadscrew

- High power brake motors with options of 0.38kW (0.50HP) or 0.75kW (1.00HP)
- Supplied fitted with proximity switches for depth, datum and 'no hole' sensing, PNP or NPN
- Quick release interchangeable leadscrew and nut assembly
- Capacity up to 10mm (3/8") in mild steel, 16mm (5/8") in aluminium depending on thread form



Quick release
Leadscrew and
Nut Assembly

AFTE470

AFTE470-180	180	0.50	17.9	60	25
AFTE470-330	330	0.50	9.8	60	25
AFTE470-550	550	0.50	5.9	60	25
AFTE470-900	900	0.50	3.6	60	25
AFTE470-1200	1200	0.50	2.7	60	25
AFTE470-1450	1450	0.50	2.2	60	25

AFTE480

AFTE480-180	180	1.00	35.8	60	26.5
AFTE480-330	330	1.00	19.5	60	26.5
AFTE480-550	550	1.00	11.7	60	26.5
AFTE480-900	900	1.00	7.2	60	26.5
AFTE480-1200	1200	1.00	5.4	60	26.5
AFTE480-1450	1450	1.00	4.4	60	26.5

leadscrew / nut assemblies AFTE470 / 480

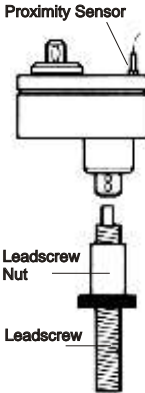
SHAPE	REPLACEMENT LEADSCREW/ NUT ONLY	ORDERING CODE	THREAD SIZE/ PITCH	REPLACEMENT LEADSCREW/ NUT ONLY	ORDERING CODE	THREAD SIZE/ PITCH	
	part no.			part no.			
	380373	L34	0.25	350823	L12	32 TPI	
	369933	L33	0.30	350833	L13	28 TPI	
	369923	L32	0.35	350843	L14	26 TPI	
	359303	L31	0.40	350853	L15	24 TPI	
	359293	L30	0.45	350863	L16	22 TPI	
	350713	L1	0.50	350873	L17	20 TPI	
	350723	L2	0.60	350883	L18	19 TPI	
	350733	L3	0.70	350893	L19	18 TPI	
	350743	L4	0.75	350903	L20	16 TPI	
	350753	L5	0.80	350913	L21	14 TPI	
	350763	L6	1.00	402793	L39	12 TPI	
	350773	L7	1.25				
	350783	L8	1.50				
	350793	L9	1.75				
	402723	L38	80 TPI		350993	L22	1/8" NPT(27 TPI)
	391533	L36	64 TPI		350923	L23	0 BA
	391543	L37	56 TPI		350933	L24	1 BA
	390333	L35	48 TPI		350943	L25	2 BA
	350803	L10	40 TPI		350953	L26	3 BA
	350813	L11	36 TPI		350963	L27	4 BA
					350973	L28	5 BA
				350983	L29	6 BA	

Control Blocks : A7 – PNP Switches, A8 – NPN Switches

Control Blocks and Interfaces

Control Blocks

A1 Full Feature Control Block
Part No. 436313

A6 Simple Control Block
Part No. 103862

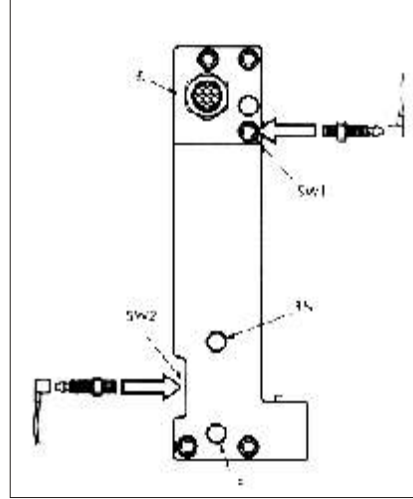
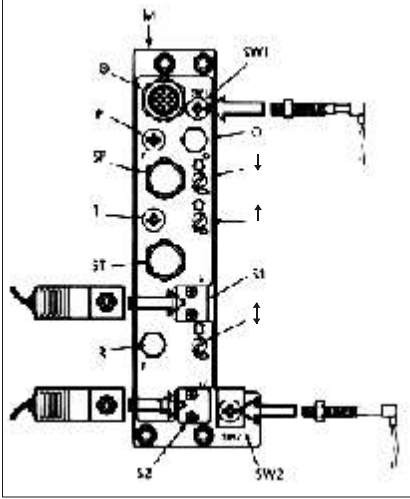

Air Connections

- R Air Return Port – Connects to breather port in nose of tool to provide extra retract capability with heavy front end attachments (1/8" BSP)
- ST Start Button – For manual operation and set-up
- 1 Remote Start Signal Port Pulse (M5)
- SP Manual Stop Button – Interrupts cycle and returns AFD to datum
- P Remote Stop Signal Port – Requires external signal pulse for returning the unit to datum rest position (M5)
- Ø Air inlet (1/4" BSP or 1/4" NPT)
- M Work Cycle Complete Port – Used for sequence control with other AFD's clamps, index tables, etc (positive at datum position) (M5)
- O Depth Stop Signal Port – Used with external circuits such as dwell or pecking (1/8" BSP)
- ↑ Retract rate adjustment control
- ↓ Advance rate adjustment control
- ↕ Feed rate adjustment control
- F Feed port (1/8" BSP)
- RN Return port (1/8" BSP)

Electrical Connections

- S1 Start solenoid
- S2 Stop solenoid
- SW1 Datum return (M8 x 1.00)
- SW2 Depth position (M8 x 1.00)

Electrical Interfaces (not included with control blocks)

C10 Part No. 438223
Comprises :
2 x M8 Proximity Switches PNP (NO)
2 x Plug-in Cables
2 x Solenoid Valves (NC)

C3 Part No. 104002
Comprises :
2 x M8 Proximity Switches PNP (NO)
2 x Plug-in Cables

Solenoid Valves
ALL 24V DC
NC – Valve normally closed
NO – Valve normally open

C11 Part No. 438233
Comprises :
2 x M8 Proximity Switches PNP (NO)
2 x Plug-in Cables
1 x Solenoid Valve (NC)
1 x Solenoid Valve (NO)

C5 Part No. 104842
Comprises :
2 x M8 Proximity Switches NPN (NO)
2 x Plug-in Cables

Proximity Switches
All 10-30V DC
NC – Normally closed
NO – Normally open

C12 Part No. 438243
Comprises :
2 x M8 Proximity Switches NPN (NO)
2 x Plug-in Cables
2 x Solenoid Valve (NC)

AFD60 / AFT60 Control Block (Supplied fitted)

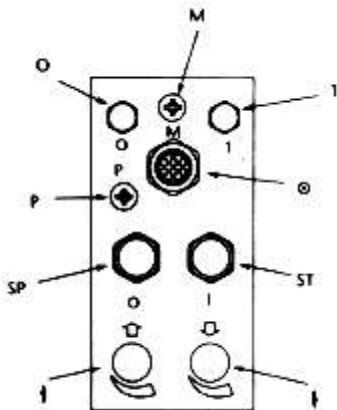

Air connection as above except M port which is negative at datum.
To invert signal use kit Part No. 104822

Electrical Inputs and Outputs

- 24VDC Switched Red
- 0V Common Black
- 24VDC Switched Green
- Switch Yellow
- Switch Common White
- Switch Blue

Electrical Interface
Part No. 79532
24V DC
Comprises:
2 metre cable Adaptor
and O ring Interface block

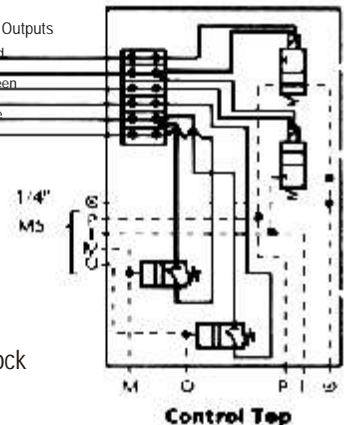

AFD Control Options

adjustable feed control unit

Minimises burring on breakthrough. Constant feed maintained in all operating conditions. Hydraulic fluid sealed for life.

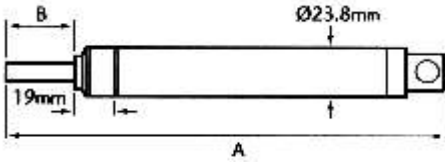

D1
D2
D3
D7
D8

MIN. PLUNGER OPERATING LOAD	MAX. LOAD	MINIMUM FEED RATE AT 2230N (500LBS) LOAD	MAX. STROKE	A	B	PART NO.
kg	kg	mm	mm	mm	mm	
2.3	544	0.73	25	199	30.1	91942
2.3	544	0.73	50	276	55.5	91952
2.3	544	0.73	75	352	80.9	91962
4.1	357	0.45	102	417	106	104452
4.1	357	0.45	127	474	132	104462

peck feed control

Used when hole depth is five times hole diameter. Helps clear chips, avoids overheating and bit breakage. Hole accuracy is improved. For use with Full Feature Control Block.

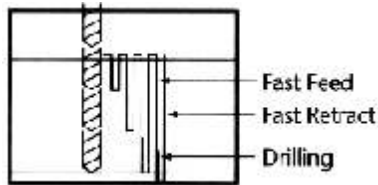

D4
D5
D6

D4	25mm (1") stroke	92282
D5	50mm (2") stroke	92292
D6	75mm (3") stroke	92302

dwell control

Used to dwell drill at bottom of stroke. Can be used to spot face, blind hole polish, friction weld plastic components and spin rivet. For use with Full Feature Control Block.

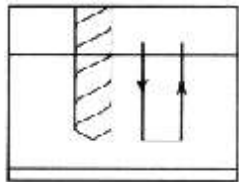

E1
—

E1	Dwell Control Unit Complete	92372
—	Dwell for AFD60	78482

skip feed control

Skip Drilling – custom H.C.U.'s available on request. Skip control ensures minimum cycle times without breakthrough burrs when drilling tubes, pocketed castings etc, with two controlled feed movements linked by a distance of fast travel.

Information Required
 1. Depth of first cut
 2. Depth of skip
 3. Depth of second cut
 4. Drill point angle

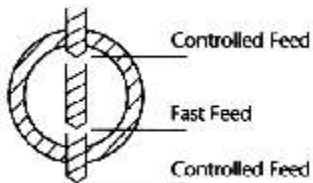

Output Spindles

AFD205 / AFD215, AFDE200, AFTE270





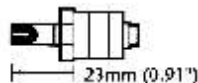
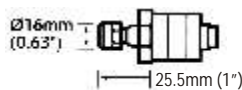
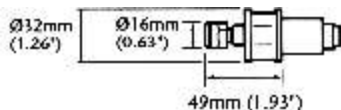

- Interchangeable modular output spindles
- Precision option for collet types, R2 and R36

FUNCTION	ORDER CODE	FEATURES	PART NO.	RECOMMENDED SPEED RANGE
High Speed Output Spindle	K42	Collect Chuck can be fitted to any AFDE200 to step up speed by 4.28: 1. Note: Max allowable speed 27000 rpm.	375263	≤5250 rpm
Collect Chuck	K2	See range of collets.	357183	≤18800 rpm
No. 1 Jacobs Taper Output Spindle	K32	No. 1 Jacobs Taper and for use with chucks or multi spindle heads	382213	≤9600 rpm
Tapping Head Output Spindle	H21	4.5-8.0MM (3/16"-5/16") capacity.	357193	≤1200 rpm

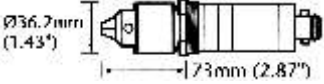
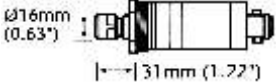
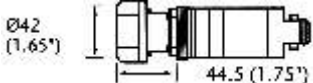

Output Spindles

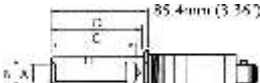
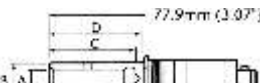
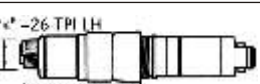
AFD415, AFDE400 / 410, AFDE600 / 610 / 620, AFTE470 / 480

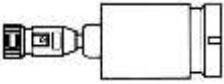
	FUNCTION	ORDER CODE	FEATURES	PART NO.	RECOMMENDED SPEED RANGE												
	10mm (3/8") key Adjustable Chuck Output Spindle	B1	Part No. Includes chuck key	327723	≤9600												
	Integral Collet Chuck Output Spindle	B2 R2	Up to 7mm (0.276") collet capacity (See Collet Range) Standard Output Assembly Precision Output Assembly	326573 384113	≤1800												
	Large Integral Collet Chuck Output Spindle	R36	Up to 16mm (0.63") collet capacity (See Collet Range) Precision Output Assembly	389273	≤1800												
	Taper Output Spindle and for use with chucks and multi spindle heads	B24 B32 B16	No.2 Jacobs Taper A = 30 (1.18") No.1 Jacobs Taper A = 24.1 (0.95") B16 Taper Output A = 34.8 (1.37")	326593 355263 368163	≤9600												
	Preset Tooling DIN5058 Output Spindle	B3	<table border="1" data-bbox="874 831 1257 913"> <thead> <tr> <th>ØA</th> <th>ØB</th> <th>C</th> <th>D</th> </tr> <tr> <th>mm</th> <th>mm</th> <th>mm</th> <th>mm</th> </tr> </thead> <tbody> <tr> <td>16</td> <td>25</td> <td>74</td> <td>79</td> </tr> </tbody> </table> Standard Output Assembly	ØA	ØB	C	D	mm	mm	mm	mm	16	25	74	79	326563	≤5450
ØA	ØB	C	D														
mm	mm	mm	mm														
16	25	74	79														
	Preset Tooling TMS Standard Output Spindle	B33	<table border="1" data-bbox="874 943 1257 1025"> <thead> <tr> <th>ØA</th> <th>ØB</th> <th>C</th> <th>D</th> </tr> <tr> <th>ins</th> <th>ins</th> <th>ins</th> <th>ins</th> </tr> </thead> <tbody> <tr> <td>5/8"</td> <td>1</td> <td>2.62</td> <td>2.85</td> </tr> </tbody> </table> Standard Output Assembly	ØA	ØB	C	D	ins	ins	ins	ins	5/8"	1	2.62	2.85	356373	≤5450
ØA	ØB	C	D														
ins	ins	ins	ins														
5/8"	1	2.62	2.85														
	AFD415, AFDE400 Externally Adjustable Screwdriver Head Output Spindle	B5 B6	1/4" fem. hex. drive. Torque range 0.3 - 11 Nm (2.7 - 100 ins. lbs.) 5/16" fem. hex. drive. Torque range 0.3 - 11 Nm (2.7 - 100 ins. lbs.)	324903 324913	≤2100												
	AFD415, AFDE400 410 Tapping Head Output Spindle	B7 B8	3.5 - 6.5mm (9/64" - 1/4") capacity 4.5 - 8mm (3/16" - 5/16") capacity	92362 92892	≤1450												
	AFDE600/610 Tapping Head Output Spindle	J19	4.5 - 9.5mm (3/16" - 3/8") capacity For use with B24 output	383813	≤1450												

AFDE700 / 710

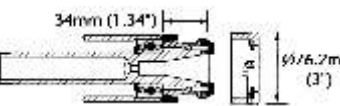
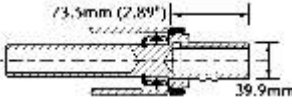
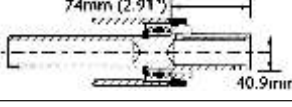
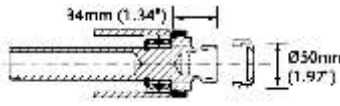
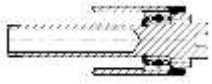
	FUNCTION	ORDER CODE	DESCRIPTION	PART NO.
	Standard machine taper. Adapts to numerous standard machining heads and equipment.	T34	ISO30 output taper, DIN 2080	362443
	Tooling spindles for 'automotive' preset tooling.	T3	Preset tooling spindle to DIN 55058 Accepts tooling to DIN 6327 28m diameter, 85mm (3.25") deep	362453
	Tooling spindles for 'automotive' preset tooling.	T33	Preset tooling spindle to T.M. Smith standard 1 1/16" diameter, 3.3"(84mm) deep	373333
	Accepts straight shank drills up to 20mm diameter (7/8")	T2	ER32 collet output spindle (see collets) Maximum drill depth 48mm (1.89")	362463
	Drive spindle for use with multi-head or angle head.	T35	Drive adaptor for multi-heads or angle head	373343

Collets

For use with B2 (326573), R2 (384113), K2 (357183), K42 (375263), ER11 TYPE

size	part no.	size	part no.	size	part no.
0.5 - 1.0 (0.020 - 0.039)	52582	2.1 - 2.5 (0.083 - 0.098)	52622	4.1 - 5.0 (0.161 - 0.197)	52652
1.1 - 1.5 (0.043 - 0.059)	52592	2.6 - 3.0 (0.102 - 0.118)	52632	5.1 - 6.0 (0.201 - 0.234)	52662
1.6 - 2.0 (0.063 - 0.079)	52602	3.1 - 4.0 (0.121 - 0.157)	52642	6.1 - 7.0 (0.240 - 0.276)	52672

For use with R36 (389273) ER25 TYPE

6.0 - 7.0 (0.236 - 0.276)	104942	10.1 - 11.0 (0.397 - 0.433)	104982	14.1 - 15.0 (0.555 - 0.591)	105032
7.1 - 8.0 (0.279 - 0.315)	104952	11.1 - 12.0 (0.437 - 0.472)	104992	15.1 - 16.0 (0.594 - 0.630)	105042
8.1 - 9.0 (0.319 - 0.354)	104962	12.1 - 13.0 (0.476 - 0.512)	105002		
9.1 - 10.0 (0.358 - 0.394)	104972	13.1 - 14.0 (0.516 - 0.551)	105022		

For use with T2 (362463) ER32 TYPE

5.0 - 6.0 (0.197 - 0.236)	105092	10.1 - 11.0 (0.397 - 0.423)	105152	15.1 - 16.0 (0.594 - 0.630)	105202
6.1 - 7.0 (0.240 - 0.276)	105102	11.1 - 12.0 (0.437 - 0.472)	105162	16.1 - 17.0 (0.634 - 0.669)	105222
7.1 - 8.0 (0.279 - 0.315)	105122	12.1 - 13.0 (0.476 - 0.512)	105172	17.1 - 18.0 (0.673 - 0.709)	105232
8.1 - 9.0 (0.319 - 0.354)	105132	13.1 - 14.0 (0.516 - 0.551)	105182	18.1 - 19.0 (0.713 - 0.748)	105242
9.1 - 10.0 (0.358 - 0.394)	105142	14.1 - 15.0 (0.555 - 0.591)	105192	19.1 - 20.0 (0.752 - 0.787)	105252

Chucks

drilling chucks

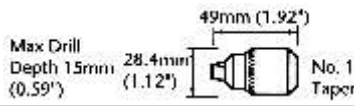
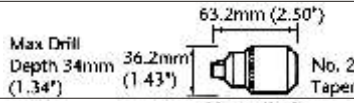
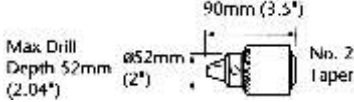
FUNCTION	DESCRIPTION	PART NO.
 <p>Max Drill Depth 15mm (0.59") 28.4mm (1.12") 49mm (1.92") No. 1 Taper</p>	6.5mm (1/4") Key Adjustable Chuck	Part No. Includes Chuck Key. Use with No. 1 standard Jacobs taper outputs K32 and B32 29492
 <p>Max Drill Depth 34mm (1.34") 36.2mm (1.43") 63.2mm (2.50") No. 2 Taper</p>	10mm (3/8") Key Adjustable Chuck	Part No. Includes Chuck Key. Use with No. 2 standard Jacobs taper output B24 34752
 <p>Max Drill Depth 52mm (2.04") ø52mm (2") 90mm (3.5") No. 2 Taper</p>	13mm (1/2") Key Adjustable Chuck	Part No. Includes Chuck Key. Use with No. 2 standard Jacobs taper output B24 34332



tapping chucks

JACOBS TAPER FITTING	A mm	B mm	Ø TAP SHANK mm	PART NO.
No. 1	64	27	3.5-6.5	29462
No. 1	64	27	4.5-8	29452
No. 2	79	37	4.5-9.5	34742
Spare or replacement Collets				2-4.5mm (5/64-3/16") Capacity to suit 29462 / 29452 75142 3.5-6.5mm (9/64-1/4") Capacity to suit 29462 / 29452 29482 4.5-8mm (3/16-5/16") Capacity to suit 29462 / 29452 29472 4.5-9.5mm (3/16-3/8") Capacity to suit 34742 36172 9-12.5mm (9/32-1/2") Capacity to suit 34742 39242

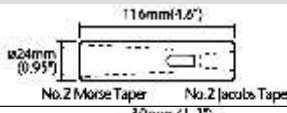
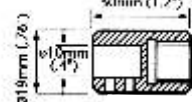
drill bit/ cutter adaptor

 <p>116mm (4.6") ø24mm (0.95") No. 2 Morse Taper No. 2 Jacobs Taper</p>	Morse Taper Adaptor	No. 2 Jacobs female taper to No. 2 Morse female taper 34862
 <p>ø19mm (0.75") ø10mm (0.4") 30mm (1.2")</p>	Ø 10mm Shank Cutter Adaptor	Fits thread of Single Collet Chuck – Part Nos. 326573 and 384113 and Multi Heads – Part Nos. 52362, 52462, 92162, 92172, 104022, 104062 53232

multiple spindle heads

 <p>Multi-spindle drilling / tapping heads</p>	Fixed and adjustable spindle multi-heads	When ordering state number of spindles, diameter of holes, material to be drilled and hole pattern required —
 <p>Angle heads/ Offset heads</p>	Angle heads available to order to suit AFDE400/410/600/610/620/700/710/AFD4115	When ordering state details of application, material to be machined, size and depth to cut —

Guards

chuck guards

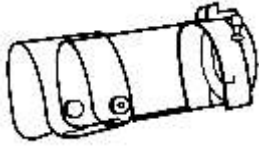

FEATURES	TOOL TYPES	PART NO.
To prevent the user inadvertently touching rotating parts	AFD205/215, AFDE200, AFTE270 AFD415, AFDE400/410, AFTE470/480 AFD60/AFDE600/610/620	66132 66122 304863

control head guard

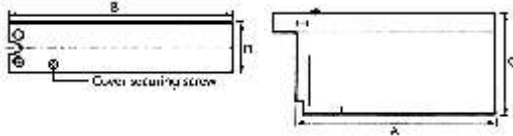

Control Top Guard to enclose crosshead (Supplied with AFD60 as standard)				AFD60, AFT60	259093
A	B	C	D		
210mm (8.3")	236mm (9.3")	108mm (4.3")	55mm (2.2")		

Silencers

AFD/AFT silencer

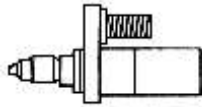

Exhaust silencer fitted with 1/4" BSP screw-in silencer	AFD205, AFD215 AFD415 AFD60, AFT60	91262 70642 70652
---	--	-------------------------

Miscellaneous Accessories

AFD205/215 HCU inverting kit

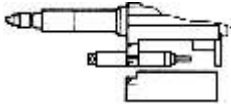

HCU Inverting Assembly	Particularly for use with AFD205 for applications with height restrictions	381003
------------------------	--	--------

AFD205/215, AFDE200, AFTE270 sealing ring

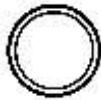

Sealing Ring	Threaded on to nose of unit in place of protection cap. Forms seal on quill shaft to prevent ingress of swarf.	104432
--------------	--	--------

Multiple Spindle Heads

- Range of adjustable spindle positions for 2, 3 and 4 spindle heads
- Special fixed spindle heads available for non standard hole patterns or dedicated applications

drilling

Multiple Spindle Head Part Numbers

NUMBER OF SPINDLES	SPINDLE CENTERS OR PCD	MAXIMUM COLLET SIZE	AFD205 AFD215 AFDE200	AFD415 AFDE400 AFDE410	AFD60	AFDE600 AFDE610 AFDE620	AFDE700 AFDE710	AFTE270	AFTE-470 AFTE-480	COLLET TYPE
2	9.5-54	4.00	174183	92142	-	-	-	-	-	A
2	12.7-64	6.50	-	92152	-	-	-	-	-	B
2	18.4-87.3	7.00	-	92162	52362	104062	-	-	-	C
2	19-95	9.50	-	106662	204183	106672	-	-	-	D
2	41.1-109.9	7.00	-	92172	52462	104022	-	-	-	C
3 inline	19.0-57.1	9.50	-	107552	107572	107562	-	-	-	D
3 PCD	27.9-104.1	9.50	-	107582	107602	107592	-	-	-	D
4 PCD	42.7-118.9	9.50	-	-	107622	107612	-	-	-	D
Fixed	-	-	-	MSD100	MSD200	MSD200	MSD300	-	-	-

tapping

2	9.5-54	4.00	-	-	-	-	-	174183	92142	A
2	12.7-64	6.50	204173	92222	-	-	-	-	92152	B
2	18.4-87.3	7.00	-	92232	-	104122	-	-	92162	C
2	19-95	9.50	-	106682	204193	106692	-	-	106662	D
2	41.1-109.9	7.00	-	92242	-	104072	-	-	92172	C
3 inline	19.0-57.1	9.50	-	107632	107652	107642	-	-	107552	D
3 PCD	27.9-104.1	9.50	-	107662	107682	107672	-	-	107582	D
4 PCD	42.7-118.9	9.50	-	-	107702	107692	-	-	-	D
Fixed	-	-	-	MST100	MST200	MST200	MSD300	-	MSD100	-

output spindles for use with multiple spindle heads

AFD205 AFD215 AFDE200	AFD415 AFDE400 AFDE410	AFD60	AFDE600 AFDE610 AFDE620	AFDE700 AFDE710	AFTE270	AFTE-470 AFTE-480
K32	B24	-	B24	T35	K32	B24



How to order

Examples:

AFDE200-2850-A1 + K32 + 174183

AFD415-3400-A6 + B24 + 107552

AFDE610-900-A1 + B24 + 107672

AFD60-2100 + 52362

AFDE70-950-A1-T35 + MSD300

Multiple Spindle Heads

dimensions

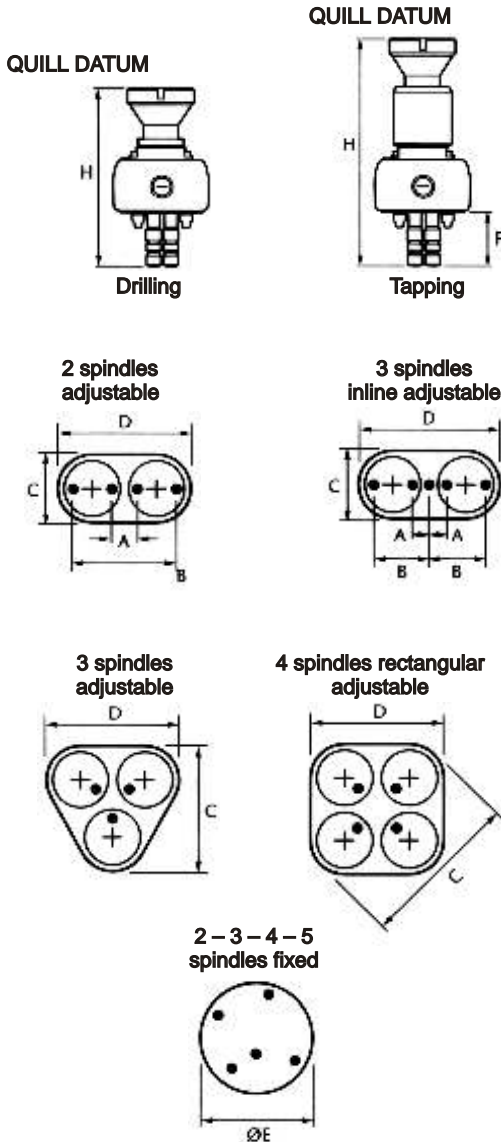

adjustable spindle

PART NO.	MAXIMUM SPEED rpm	MAX. / MINI. CENTERS mm	MINIMUM PCD mm	MAXIMUM PCD mm	C mm	D mm	F mm	H mm
52362	8500	18.4-87.3	-	-	62	115	60	193.5
52462	8500	41.1-109.9	-	-	62	137	60	193.5
92142	5300	9.5-54	-	-	50.8	83	50.8	175.4
92152	5300	12.7-64	-	-	50.8	83	50.8	175.4
92162	8500	18.4-87.3	-	-	62	115	60	196
92172	8500	41.1-109.9	-	-	62	137	60	196
92222	1400	12.7-64	-	-	50.8	83	50.8	233.8
92232	1400	18.4-87.3	-	-	62	115	60	253
92242	1400	41.1-109.9	-	-	62	137	60	253
104022	8500	41.1-109.9	-	-	62	137	60	196
104062	8500	18.4-87.3	-	-	62	115	60	196
104072	1400	41.1-109.9	-	-	62	137	60	233.5
104122	1400	18.4-87.3	-	-	62	115	60	196
106662	5300	19-95	-	-	76	124	68.3	212
106672	5300	19-95	-	-	76	124	68.3	211
106682	1500	19-95	-	-	76	124	68.3	261.5
106692	1500	19-95	-	-	76	124	68.3	260
107552	5300	19-57.1	-	-	99.2	142.9	68.3	212.3
107562	5300	19-57.1	-	-	99.2	142.9	68.3	188
107572	5300	19-57.1	-	-	99.2	142.9	68.3	212.3
107582	5300	-	27.9	104.1	120.3	132.6	68.3	212.3
107592	5300	-	27.9	104.1	120.3	132.6	68.3	211.2
107602	5300	-	27.9	104.1	120.3	132.6	68.3	188
107612	5300	-	42.7	118.9	147.6	130.4	68.3	211.2
107622	5300	-	42.7	118.9	147.6	130.4	68.3	188
107632	900	19-57.1	-	-	99.2	142.9	68.3	261.5
107642	900	19-57.1	-	-	99.2	142.9	68.3	260
107652	900	19-57.1	-	-	99.2	142.9	68.3	259.9
107662	900	-	27.9	104.1	120.3	132.6	68.3	261.5
107672	900	-	27.9	104.1	120.3	132.6	68.3	260
107682	900	-	27.9	104.1	120.3	132.6	68.3	259.9
107692	900	-	42.7	118.9	147.6	130.4	68.3	260
107702	900	-	42.7	118.9	147.6	130.4	68.3	259.9
174183	5300	9.5-54	-	-	50.8	83	50.8	169.5
2041173	5300	12.7-64	-	-	50.8	83	50.8	206.1
204183	5300	19-95	-	-	76	124	68.3	188
204193	700	19-95	-	-	76	124	68.3	260.4

fixed spindle

PART NO.	MAXIMUM SPEED rpm	MAX. / MINI. CENTERS mm	MINIMUM PCD mm	MAXIMUM PCD mm	OE mm	F mm	H mm
MSD100	5300	9.5-63.5	9.5/12.7	63.5	56-81.8	37/40.5	168/175.4
MST100	1400	9.5-63.5	9.5/12.7	63.5	56-81.8	37/40.5	227.8/233.8
MSD200	5300	19-95	19	95	100.8-126.2	57.2	211.1
MST200	700	19-95	19	95	100.8-126.2	57.2	260
MSD300	3500	17.4-157	17.4	157	150-225	26-41	221-241
MST300	1500	17.4-157	17.4	157	150-225	26-41	221-241

Spindle Coolant Adaptor for the AFDE700 Series



Two types of spindle coolant adaptors are now available for the AFDE700/710.

The adaptors are available with the ER32 style collect holder (maximum collet 20mm) or a 32mm 'U' drill holder. Both are supplied with DIN2080 ISO30 male tapers to fit the T34 output and include a support pillar mounted to the front of the AFDE to take the torque reaction.

The heads are fully sealed and coolant enters the head via a port on the side of the head suitable for 10mm O.D. and 7mm I.D. pipe.

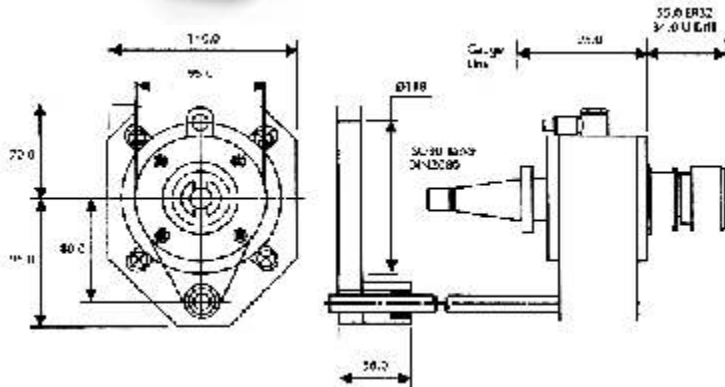

Maximum Speed – 5000 rpm
 Maximum Coolant Pressure – 25 bar
 Weight – Approx 7 kg (15.5lbs)

ER Collet Type
 32mm 'U' Drill Type

Part No. 107792
 Part No. 107802

Multiple Spindle Heads

Collets



- Collects for multiple spindle heads
- Types A, B and D are threaded types
- Type C are Er11 type

SIZE	COLLET TYPE			
	A	B	C	D
mm				
0.5			52582	
0.6			52582	
0.7			52582	
0.8			52582	
0.9			52582	
1	60002	39442	52582	
1.1	60022	39452	52592	
1.2	60032	39462	52592	
1.3	60042	39472	52592	
1.4	60052	39482	52592	
1.5	60062	39492	52592	
1.6	60072	27852	52602	
1.7	60082	39502	52602	
1.8	60092	27862	52602	
1.9	60102	39522	52602	
2	60122	27872	52602	39302
2.1	60132	27882	52622	39322
2.2	60142	27892	52622	39322
2.3	60152	27902	52622	39342
2.4	60162	27922	52622	39352
2.5	60172	27932	52622	39362
2.6	60182	27942	52632	39372
2.7	60192	27952	52632	39382
2.8	60202	27962	52632	39392
2.9	60222	27972	52632	39402
3	60232	27982	52632	39422
3.1	60242	27992	52642	39432
3.2	60252	28002	52642	34902
3.3	60262	28032	52642	34932
3.4	60272	28042	52642	34942
3.5	60282	28052	52642	34952
3.6	60292	28062	52642	34962
3.7	60302	28082	52642	34982
3.8	60322	28092	52642	34992
3.9	60332	28102	52642	35002
4	60342	28122	52642	35022

SIZE	COLLET TYPE			
	A	B	C	D
mm				
4.1		28132	52652	35032
4.2		28142	52652	35042
4.3		28152	52652	35052
4.4		28162	52652	35062
4.5		28172	52652	35072
4.6		28182	52652	35082
4.7		28192	52652	35092
4.8		28202	52652	35102
4.9		28222	52652	35122
5		28232	52652	35132
5.1		28252	52662	35152
5.2		28272	52662	35172
5.3		28282	52662	35182
5.4		28292	52662	35192
5.5		28302	52662	35202
5.6		28322	52662	35222
5.7		28332	52662	35232
5.8		28342	52662	35242
5.9		28352	52662	35252
6		28372	52662	35272
6.1		28382	52672	35282
6.2		28392	52672	35292
6.3		28402	52672	35302
6.4		39532	52672	35332
6.5		39542	52672	35342
6.6			52672	35352
6.7			52672	35362
6.8			52672	35382
6.9			52672	35392
7			52672	35402

SIZE	COLLET TYPE			
	A	B	C	D
mm				
7.1				35422
7.2				35432
7.3				35452
7.4				35462
7.5				35472
7.6				35492
7.7				35502
7.8				35522
7.9				35532
8				35552
8.1				35562
8.2				35572
8.3				35582
8.4				35592
8.5				35602
8.6				35622
8.7				35632
8.8				35652
8.9				35672
9				35682
9.1				35692
9.2				35722
9.3				35732
9.4				35752
9.5				35762

Applications



Auto Feed Drill and Tapper Applications

Application

- Hydraulic cylinder
- Drilling and tapping Ø6mm holes in alloy steel

Tool Type

- 4 AFD41-1250-A1-B2 with skip feed control unit
- 1 AFTE47-830-A6-B24 with tapping chuck and control box
- 1 R12104X 4 station rotary table
- Parallel and base clamps, tubes

Cycle Time

- 20 seconds

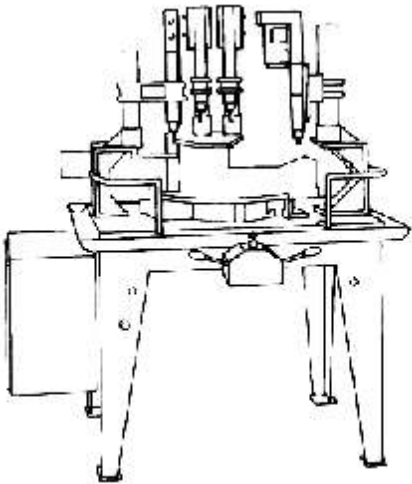

Application

- Carburetor components
- Drilling 2 Ø3mm and a Ø10mm hole in aluminium casting

Tool Type

- 2 AFD22-4350-A1-K2 with hydraulic control units
- 1 AFD60-1600
- Base and bar clamps
- 1 R12104H 4 station rotary table with hydrocheck

Cycle Time

- 5 seconds per component

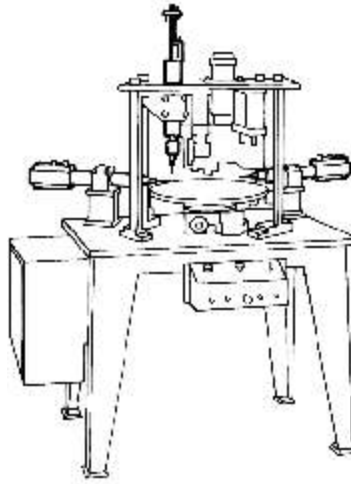

Application

- Aluminium casting
- Drilling and tapping Ø8mm holes

Tool Type

- 2 AFD41-3400-A6-B2
- 2 AFD41-790-A6-B8
- All tools fitted with interface kits and exhaust collectors
- Mounted on bar clamps to vertical slides for positioning

Cycle Time

- Under 20 seconds

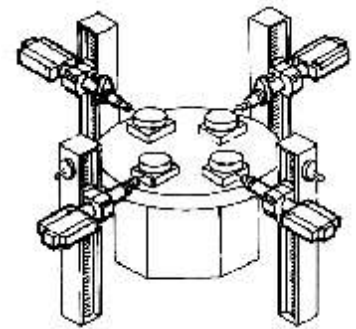

Application

- Automotive component
- Drilling Ø6.4mm hole, 32mm deep and 4 Ø5.5mm holes in mild steel

Tool Type

- AFD60-3000 fitted with 2 spindle head and hydraulic check unit
- AFD41-2100-A1-B1 fitted with 50mm peck feed kit
- 2 AFD22-2700-A1-K32 with chucks and hydraulic check units
- Mounted on swivel and right angle clamps, base clamps and tubes

Cycle Time

- 12 seconds

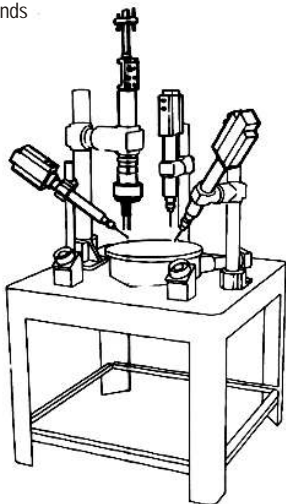

Application

- Air conditioning parts
- Drilling 2 Ø6mm holes and spot facing 6 Ø16mm holes 1.5mm deep in cast aluminium replacing operations performed by a CNC machine

Tool Type

- 2 AFDE41-2350-A1-B2 fitted with interface kits and hydraulic check units
- AFE70-460-A1-T35 fitted with a 6 spindle head and dwell kit
- AFDE41 in bar, swivel, right angle and base clamps and tube

Cycle Time

- 8-9 seconds

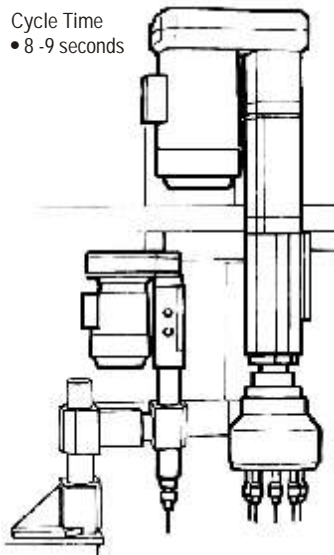

Application

- Stainless steel component
- Drilling Ø4mm and Ø8mm holes

Tool Type

- AFDE41-1220-A1-B1 fitted with 25mm hydraulic check units
- AFDE62-860-A1-B1 fitted with 25mm hydraulic check unit
- Both tools mounted in swivel, right angle and base clamps with tubes

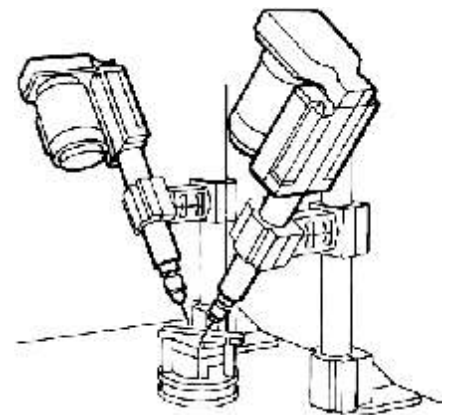

Cycle Time

- 8 seconds



Mounting Clamps

Used with AFD type			
	Base Clamp	Swivel clamp	Right Angle Clamp
	Part No.	Part No.	Part No.
AFD205, AFDE200, AFTE270	61842	61802	61822
AFD415, AFDE400/410, AFTE470/480	76302	76332	76342
AFD60, AFT60, AFDE600/610/620	32542	32502	32522

Used with AFD type			
	Bar Clamp	Parallel clamp	Pillar Support
	Part No.	Part No.	Part No.
AFD205, AFDE200, AFTE270	61852	61832	61862
AFD415, AFDE400/410, AFTE470/480	76272	76352	—
AFD60, AFT60, AFDE600/610/620	32532	32492	—

Mounting Columns

Used with AFD type	Column Length						
	228mm	305mm	457mm	610mm	760mm	915mm	1220mm
	Part No.						
AFD205, AFDE200, AFTE270	39702	39722	39732	39742	39752	—	—
AFD415, AFDE400/410, AFTE470/480	9452	9462	9472	9482	—	—	—
AFD60, AFT60, AFDE600/610/620	—	—	—	32562	—	32572	32582