

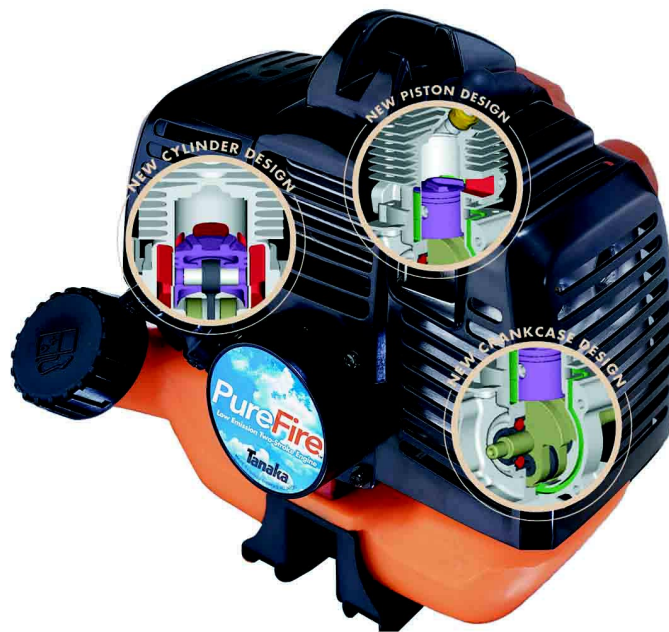

# Owner's Manual

## PF-4000, PF-4010, PF-4210 MULTI-PURPOSE ENGINE

Date 09-26-01



*Supplier To The Outdoor Power Equipment Industry*

ISM, Inc. • 1028 4<sup>th</sup> Street SW • Auburn, WA 98001 • Phone: (253) 333-1200 • Fax: (253) 333-1212



## WARNING

The engine exhaust from this product contains chemicals known to the State of California to cause cancer, birth defects and other reproductive harm.



Read, understand and follow all warnings and instructions in this manual and on the unit.

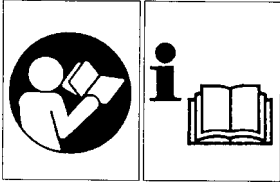

It is important that you read, fully understand and observe the following safety precautions and warnings for use of this engine, as well as the equipment it powers. Careless or improper use may cause serious or fatal injury.

### Warnings and safety instructions.

#### Operator Safety

- Never let a child or inexperienced person operate the machine.
- Never start or run the engine inside a closed room or building. Breathing exhaust fumes can kill.

#### Equipment Safety

- Inspect the engine and equipment before each use. Replace damaged parts. Check for fuel leaks and make sure all fasteners are in place and securely fastened.
- Replace parts that are cracked, chipped or damaged in any way before using the engine and equipment.

#### Fuel Safety

- Mix and pour fuel outdoors and where there are no sparks or flames.
- Use a container approved for fuel.
- Do not smoke or allow smoking near fuel or the tool or while using the tool.
- Wipe up all fuel spills before starting engine.
- Move at least 3 m (10 ft) away from fueling site before starting engine.
- Stop engine before removing fuel cap.
- Empty the fuel tank before storing. It is recommended that the fuel be emptied after each use. If fuel is left in the tank, store so fuel will not leak.
- Store engine and fuel in area where fuel vapors cannot reach sparks or open flames from water heaters, electric motors or switches, furnaces, etc.

#### Maintenance Safety

- Maintain the engine and equipment according to recommended procedures.

- Disconnect the spark plug before performing maintenance except for carburetor adjustments.
- Keep others away when making carburetor adjustments.
- Use only genuine replacement parts as recommended by the manufacturer.

#### Transport and storage

- Allow the engine to cool, empty the fuel tank, and secure the engine and equipment before storing or transporting in a vehicle.
- Empty the fuel tank before storing. It is recommended that the fuel be emptied after each use. If fuel is left in the tank, store so fuel will not leak.
- Store out of the reach of children.
- Clean the unit carefully and store it in a dry place.
- Make sure engine switch is off when transporting or storing.

If situations occur which are not covered in this manual, take care and use good judgment. Contact your dealer if you need assistance.

Pay special attention to statements preceded by the following words:



#### **WARNING!**

Indicates a strong possibility of severe personal injury or loss of life, if instructions are not followed.

#### **CAUTION!**

Indicates a possibility of personal injury or equipment damage, if instructions are not followed.

#### **NOTE!**

Helpful information for correct function and use.

## Operating procedures



### WARNING!

This is a two-stroke engine. Always run the engine on fuel, which is mixed with oil. Provide good ventilation, when fueling or handling fuel.

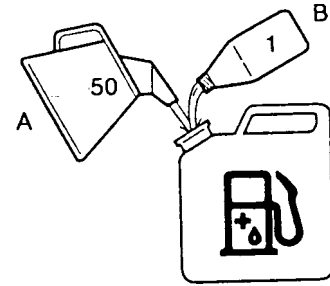

### Fuel

- Always use branded 89 octane unleaded gasoline.
- Use Tanaka two-cycle oil or a quality two-cycle oil at mixing ratio of 50:1 (Gasoline (A) : Oil (B)).
- Never use multi-grade oil (10 W/30) or waste oil.
- Always mix fuel and oil in a separate clean container.
- Always start by filling half the amount of fuel, which is to be used. Then add the whole amount of oil. Mix (shake) the fuel mixture.
- Add the remaining amount of fuel.
- Mix (shake) the fuel-mix thoroughly before filling the fuel tank.

### Fueling



### WARNING!

- Always shut off the engine before refueling.
- Slowly open the fuel tank, when removing cap, so that possible over-pressure disappears.
- Tighten the fuel cap carefully, after fueling.
- Always move the engine/equipment at least 3 m (10 ft.) from the fueling area before starting.

Before fueling, clean the tank cap area carefully, to ensure that no dirt falls into the tank.

Make sure that the fuel is well mixed by shaking the container, before fueling.

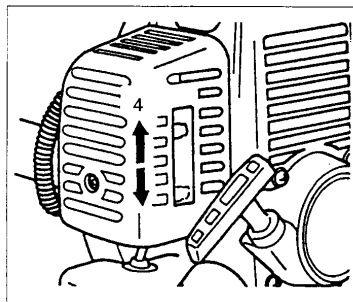
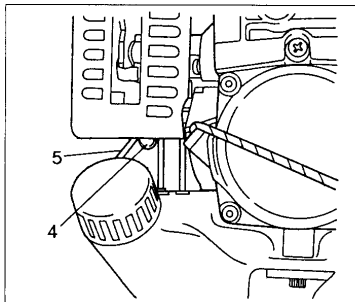

## Starting

1. Set ignition switch to the ON position.
- \*\*Push priming bulb (4) several times so that fuel flows through return pipe (5).
2. Set choke lever to CLOSED position (4).
3. Pull recoil starter briskly, taking care to keep the handle in your grasp and not allowing it to snap back.
4. When you hear the engine want to start, return choke lever to RUN position (open). Then pull recoil starter briskly again.

### NOTE!

If engine does not start, repeat procedures from 2 to 5.

## Maintenance

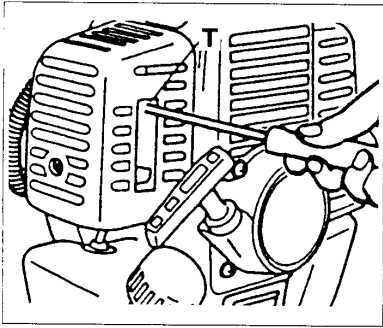

Fig. 3-1

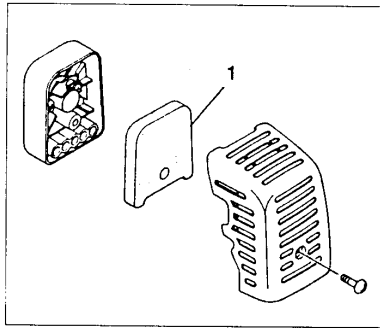

Fig. 3-2

**MAINTENANCE, REPLACEMENT, OR REPAIR OF THE EMISSION CONTROL DEVICES AND SYSTEMS MAY BE PERFORMED BY ANY NONROAD ENGINE REPAIR ESTABLISHMENT OR INDIVIDUAL.**

### Carburetor adjustment (Fig. 3-1)

#### ⚠ WARNING!

Never start the engine without the equipment attached! Otherwise the clutch can come loose and cause personal injuries.

In the carburetor, fuel is mixed with air. When the engine is test run at the factory, the carburetor is basically adjusted. The carburetor has one adjustment possibility:

T = Idle speed adjustment screw.

#### Idle speed adjustment (T)

Check that the air filter is clean. If adjustment is required, close (clockwise) the T-screw, with the engine running.

You have reached the correct idle speed when the engine runs smoothly in all positions well below the rpm when the equipment starts to rotate.

If the equipment still rotates after idle speed adjustment, contact your service workshop.

#### NOTE!

Standard Idle rpm is 2500-3000 rpm.

### Air filter (Fig. 3-2)

The air filter must be cleaned from dust and dirt in order to avoid:

- Carburetor malfunctions.
- Starting problems.
- Engine power reduction.
- Unnecessary wear on the engine parts.
- Abnormal fuel consumption.

Clean the air filter daily or more often if working in exceptionally dusty areas.

#### Cleaning the air filter

Remove the air filter cover and the filter (1).

Rinse it in warm soap suds. Check that the filter is dry before reassembly. An air filter that has been used for some time cannot be cleaned completely. Therefore, it must regularly be replaced with a new one. A damaged filter must always be replaced.

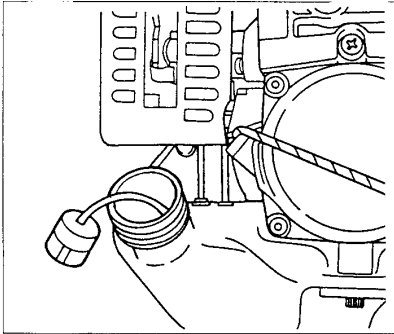

Fig. 3-2B

### Fuel Filter (Fig. 3-2B)

Drain all fuel from fuel tank and pull fuel filter line from tank. Pull filter element out of holder assembly. Replace filter if it appears to be discolored or hardened from use. The filter has a white, felt-like appearance when new.

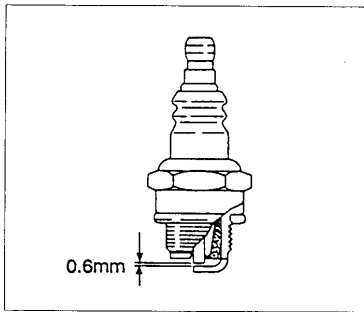

Fig. 3-3

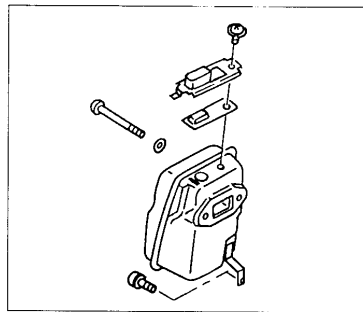

Fig. 3-4

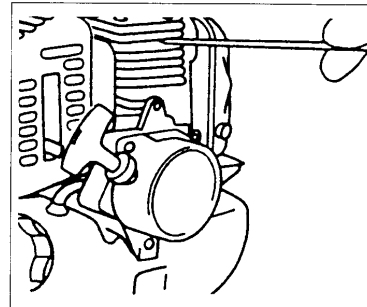

Fig. 3-5

### Spark plug (Fig. 3-3)

The spark plug condition is influenced by:

- An incorrect carburetor setting.
- Wrong fuel mixture (too much oil in the gasoline)
- A dirty air filter.
- Difficult running conditions (such as cold weather).

These factors cause deposits on the spark plug electrode, which may result in malfunction and starting difficulties. If the engine is low on power, difficult to start or runs poorly at idling speed, always check the spark plug first. If the spark plug is dirty, clean it and check the electrode gap. Readjust if necessary. The correct gap is 0.6 mm (.024"). The spark plug should be replaced after about 100 operation hours or earlier if the electrode is badly eroded.

### NOTE!

In some areas, local law requires using a resistor spark plug to suppress ignition signals. If this machine was originally equipped with resistor spark plug, use the same type of spark plug for replacement.

### Muffler (Fig. 3-4)

Remove the muffler and clean excess carbon from the exhaust port or muffler inlet every 100 hours of operation.

If you find corrosion on the muffler, replace it.

### Cylinder (Engine cooling) (Fig. 3-5)

The engine is air cooled, and air must circulate freely around engine and over cooling fins on cylinder head to prevent overheating.

Every 100 Operating hours, or once a year (more often if conditions require), clean fins and external surfaces of engine of dust, dirt and oil deposits which can contribute to improper cooling.

### NOTE!

Do not operate engine with engine shroud or muffler guard removed as this will cause overheating and engine damage.

**Specifications**

**MODEL**

**PF-4000**



Engine Size (ml) ..... 40 (2.44 cu. in.)



Spark Plug ..... CHAMPION CJ8Y  
or equivalent



Fuel Tank Capacity (l) ..... 1.0 (30.4 fl.oz)



Dry Weight (kg) ..... **3.3 (8.6 lbs)**

**U.S. EPA PHASE 1 / STATE OF CALIFORNIA  
EMISSION CONTROL WARRANTY STATEMENT**

THE CALIFORNIA AIR RESOURCES BOARD AND TANAKA KOGYO CO., LTD. ARE PLEASED TO EXPLAIN THE EMISSION CONTROL SYSTEM WARRANTY ON YOUR TANAKA ENGINE. NEW SMALL OFF ROAD ENGINES MUST BE DESIGNED, BUILT AND EQUIPPED TO MEET STRINGENT CALIFORNIA ANTI-SMOG STANDARDS. TANAKA KOGYO CO., LTD. MUST WARRANT THE EMISSION CONTROL SYSTEM ON SMALL OFF ROAD ENGINE FOR THE PERIODS OF TIME LISTED BELOW, PROVIDED THERE HAS BEEN NO ABUSE, NEGLIGENCE OR IMPROPER MAINTENANCE OF YOUR LAWN AND GARDEN EQUIPMENT ENGINE.

YOUR EMISSION CONTROL SYSTEM INCLUDES PARTS SUCH AS THE CARBURETOR, THE IGNITION SYSTEM AND THE CATALYTIC CONVERTER. ALSO INCLUDED ARE THE BELTS, HOSES AND CONNECTORS THAT ARE PART OF THE ENGINE.

WHERE A WARRANTABLE CONDITION EXISTS, TANAKA KOGYO CO., LTD. WILL REPAIR YOUR LAWN AND GARDEN EQUIPMENT ENGINE AT NO COST TO YOU INCLUDING DIAGNOSIS, PARTS AND LABOR.

**MANUFACTURE'S WARRANTY COVERAGE:**

THE 1995 AND LATER SMALL OFF ROAD ENGINES ARE WARRANTED FOR TWO YEARS. IF ANY EMISSION RELATED PART ON YOUR ENGINE IS DEFECTIVE, THE PART WILL BE REPAIRED OR REPLACED BY TANAKA KOGYO CO., LTD.

**OWNER'S WARRANTY RESPONSIBILITIES:**

AS THE SMALL OFF ROAD ENGINE OWNER, YOU ARE RESPONSIBLE FOR THE PERFORMANCE OF THE REQUIRED MAINTENANCE LISTED IN YOUR OWNER'S MANUAL. TANAKA KOGYO CO., LTD. RECOMMENDS THAT YOU RETAIN ALL RECEIPTS COVERING MAINTENANCE ON YOUR SMALL OFF ROAD ENGINE, BUT TANAKA KOGYO CO., LTD. CANNOT DENY WARRANTY SOLELY FOR THE LACK OF RECEIPTS OR FOR YOUR FAILURE TO ENSURE THE PERFORMANCE OF ALL SCHEDULED MAINTENANCE.

AS THE SMALL OFF ROAD ENGINE OWNER, YOU SHOULD BE AWARE, HOWEVER, THAT TANAKA KOGYO CO., LTD. MAY DENY YOU WARRANTY COVERAGE IF YOUR SMALL OFF ROAD ENGINE OR A PART HAS FAILED DUE TO ABUSE, NEGLIGENCE, IMPROPER MAINTENANCE OR UNAPPROVED MODIFICATIONS.

YOU ARE RESPONSIBLE FOR PRESENTING YOUR SMALL OFF ROAD ENGINE TO A TANAKA KOGYO CO., LTD. SERVICE CENTER AS SOON AS A PROBLEM EXISTS. THE WARRANTY REPAIRS SHOULD BE COMPLETED IN A REASONABLE AMOUNT OF TIME, NOT TO EXCEED 30 DAYS.

IF YOU HAVE ANY QUESTIONS REGARDING YOUR WARRANTY RIGHTS AND RESPONSIBILITIES, YOU SHOULD CONTACT TANAKA KOGYO CO., LTD. C/O INTERNATIONAL SALES & MARKETING, INC., CUSTOMER SERVICE REPRESENTATIVE AT (253) 333-1200.