

Quickie G-424

User

Instruction

Manual &

Warranty

SUPPLIER:
THIS MANUAL MUST BE GIVEN TO THE
RIDER OF THIS WHEELCHAIR.

RIDER:
BEFORE USING THIS WHEELCHAIR
READ THIS ENTIRE MANUAL AND SAVE
FOR FUTURE REFERENCE.



SUNRISE LISTENS

Thank you for choosing a Quickie wheelchair. We want to hear your questions or comments about this manual, the safety and reliability of your chair, and the service you receive from your Sunrise supplier. Please feel free to write or call us at the address and telephone number below:

SUNRISE MEDICAL

**Customer Service Department
7477 East Dry Creek Parkway
Longmont, Colorado 80503
(800) 333-4000 or (303) 218-4500**

Be sure to return your warranty card, and let us know if you change your address. This will allow us to keep you up to date with information about safety, new products and options to increase your use and enjoyment of this wheelchair. If you lose your warranty card, call or write and we will gladly send you a new one.

FOR ANSWERS TO YOUR QUESTIONS

Your authorized supplier knows your wheelchair best and can answer most of your questions about chair safety, use and maintenance. For future reference, fill in the following:

Supplier: _____

Address: _____

Telephone: _____

Serial #: _____ **Date/Purchased:** _____

I I . T A B L E O F C O N T E N T S

I. INTRODUCTION	3
II. TABLE OF CONTENTS	4
III. YOUR CHAIR AND ITS PARTS	6
IV. NOTICE - READ BEFORE USE	8
V. EMI (ELECTROMAGNETIC INTERFERENCE)	9
A. What is EMI.....	9
B. What Effect Can EMI Have	9
C. Sources of EMI	10
D. Distance From the Source.....	10
E. Immunity Level	10
F. Report All Suspected EMI Incidents.....	11
VI. GENERAL WARNINGS	12
A. Notice to Rider	12
B. Notice to Attendants	12
C. Weight Limit	12
D. Controller Settings.....	13
E. EMI.....	13
F. Safety Check-List	13
G. Changes & Adjustments	13
H. When Seated in a Parked Wheelchair	14
I. Environmental Conditions	14
J. Terrain.....	14
K. Street Use	15
L. Motor Vehicle Safety	15
M. Center of Balance	15
N. Transfers	16
O. Reaching or Leaning.....	17
P. Dressing or Changing Clothes	17
Q. Obstacles	18
R. Driving in Reverse	18
S. Ramps, Slopes & Sidehills	18
T. To Reduce the Risk of Falls, Tip-over or Loss of Control	19
U. Ramps at Home & Work	19
V. Wheelchair Lifts	20
W. Curbs & Single Steps	20
X. Stairs	20
Y. Escalators	20
VII. WARNINGS: COMPONENTS & OPTIONS	21
A. Armrests.....	21
B. Batteries	21
C. Cushions.....	21
D. Fasteners	21
E. Footplate & Footrests	22
F. Motor Lock	22
G. On/Off Switch.....	22
H. Pneumatic Tires.....	22
I. Positioning Belts (Optional).....	23
J. Push Handles	23
K. Seating Systems.....	23
L. Upholstery Fabric.....	24
M. Suspension	24
VIII. TIPS FOR ATTENDANTS	25
A. To Climb a Curb or Single Step	25

I I . T A B L E O F C O N T E N T S

B. To Descend a Curb or Single Step	25
IX. SET UP, ADJUSTMENT & USE	26
Notes	26
Tools You Will Need	27
Check Out.....	27
A. Battery Removal.....	28
B. Footplate Height Adjustment	28
C. Swing-Away Footrests (Available with seat frame).....	29
D. Elevating Legrest (Optional)	29
E. Integral Joystick.....	29
F. Remote Joystick Installation.....	30
G. To Adjust the Height of the Remote Joystick	30
H. Remote Joystick Swing-Away Retractable Mount (Optional).....	30
I. Flip Back Width Adjustable Armrests (Contour & High Back Contour seat)	31
J. Angle Adjustment Armrest.....	31
K. Dual Post Height Adjustable Flip Back Armrest	31
L. Backrest	32
M. Folding Backrest	32
N. Folding Backrest	33
O. Seat Height Adjustment	33
P. Seat Removal.....	34
Q. Shroud Removal	34
R. Parapak Seat Sling (Seat Frame).....	34
S. Seat Depth.....	35
T. Check-Out.....	35
X. OPERATING GUIDE	36
A. Performance Control Settings.....	36
B. QTRONIX Programmer Pad (Optional).....	36
C. Thermal Roll-Back	37
D. Circuit Breakers	37
E. Integral Joystick.....	37
F. Remote Joystick Assembly	38
G. Motor Locks	40
XI. BATTERIES	41
A. Introduction.....	41
B. Battery Charger	41
C. Acid Burns	42
D. Connecting Batteries in Battery Well	42
E. Charging Batteries	43
F. Disposing of Batteries	44
XII. MAINTENANCE	45
A. Notes	45
B. Cleaning	45
C. Storage Tips	45
D. Battery Maintenance	45
E. Pneumatic Tires.....	46
F. To Repair or Replace a Tire.....	47
G. Motor Brushes	48
H. Ordering Parts	48
I. Maintenance Chart	48
XIII. WIRING DIAGRAMS	49
XIV. SUNRISE LIMITED WARRANTY	51

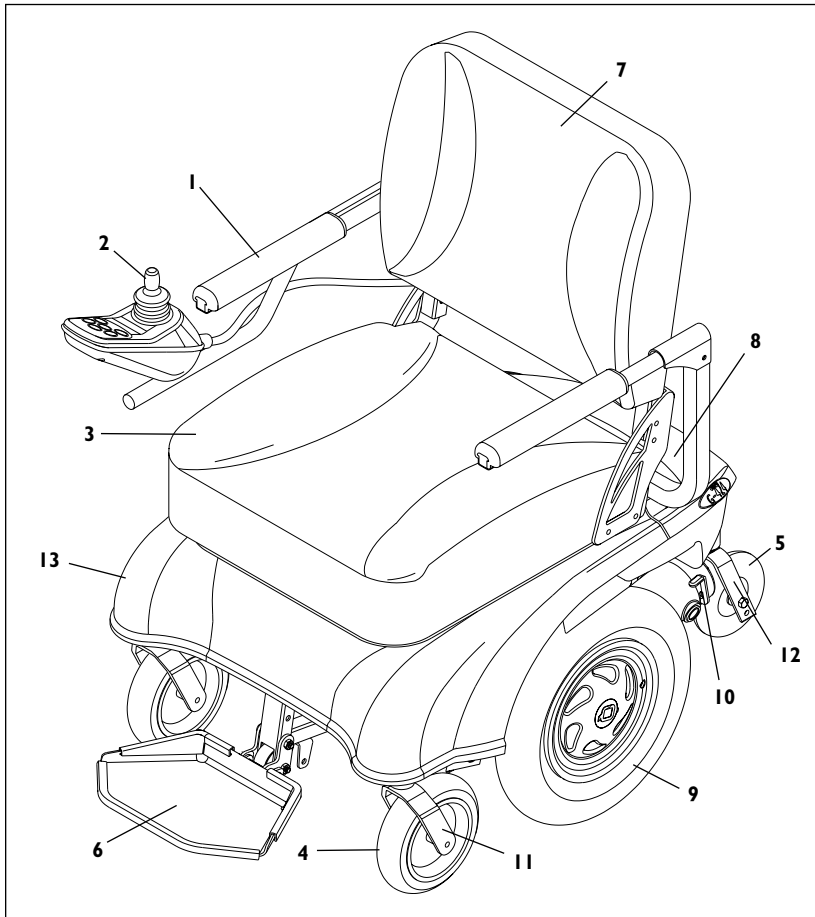

QUICKIE G - 4 2 4

- | | |
|---------------------------------|---------------------------------|
| 1. Flip back armrest | 7. Fold down seat back |
| 2. Integral controller joystick | 8. Battery deck lid (not shown) |
| 3. Contour seat | 9. 14" drive wheels |
| 4. Front caster 8" | 10. Freewheel release |
| 5. Rear stabilizing caster 5" | 11. Caster Fork (front) |
| 6. Single plate foot platform | 12. Caster Fork (rear) |
| | 13. Shroud |

QUICKIE G-424

Weight

125 lb. without batteries

Drive Wheels

14" Mag

Tire types:

Standard - pneumatic

Option - airless insert

Option - Solid

Joystick

Standard - integral (right-hand or left-hand mount)

Optional - remote (right-hand or left-hand mount)

Optional - swing-away retractable

Batteries

(2 deep cycle batteries required to operate chair)

Option - Group 24 gel or 22NF gel

Battery Charger

Standard - off board (Lester)

Colors

Refer to Order Form.

Seats

Standard: Contour seat (18" wide)

Option: High Back Contour seat (18.5" wide)

Option: Seat frame (14"- 20" wide)

Upholstery

Soft vinyl: Black, Gray

Backrest

Folding (Contour & Seat Frame option only)

Footrest

Standard - Foot platform

Option - swing-away with composite footplates and heel loops. (Seat Frame only)

Option - elevating legrests, multiposition and angle-adjustable footplate (seat frame only)

Casters (front)

Standard - 8" airless insert

Option - 8" pneumatic

Option - 8" solid

Casters (rear)

Standard - 5" solid

Armrests

Flip back 12" arm pad

Suspension

Standard - all wheel independent

Drives

Right angle worm/spur

All features may not be available with some chair setups or in conjunction with another chair feature. Please consult your supplier for more information. Your authorized supplier can also provide you with more information on accessories.

A. CHOOSE THE RIGHT CHAIR & SAFETY OPTIONS

Sunrise provides a choice of many power wheelchair styles, sizes and adjustments to meet the needs of the rider. However, final selection of a wheelchair rests solely with you and your health care professional. Choosing the best chair for you depends on such things as:

1. Your size, disability, strength, balance and coordination.
2. Your intended use, and your level of activity.
3. The types of hazards you must overcome in daily use (in areas where you are likely to use your chair).
4. The need for options for your safety and comfort (such as positioning belts or special seat systems).

B. ADJUST CHAIR TO YOUR ABILITY

You need to work with your doctor, nurse or therapist, and your supplier, to fit this chair and adjust the controller settings for your level of function and ability.

C. REVIEW THIS MANUAL OFTEN

Before using this chair you, and each person who may assist you, should read this entire Manual and make sure to follow all instructions. Review the warnings often, until they are second nature to you.

D. WARNINGS

The word “WARNING” refers to a hazard or unsafe practice that may cause severe injury or death to you or to other persons. The “Warnings” are in four main sections, as follows:

1. V — EMI

Here you will learn about electromagnetic interference and how it can affect your chair.

2. VI — GENERAL WARNINGS

Here you will find a safety checklist and a summary of risks you need to be aware of before you ride this chair.

3. VII — WARNINGS — COMPONENTS & OPTIONS

Here you will learn about your chair. Consult your supplier and your health care professional to help you choose the best set-up and options for your safety.

4. XI — BATTERIES

Here you will learn about battery and charger safety, and how to avoid injury.

Note: Where they apply, you will also find “Warnings” in other sections of this Manual.

⚠ WARNING

Heed all warnings to reduce the risk of unintended brake release or chair movement:

1. Beware of the danger from hand-held transceivers. Never turn on or use a hand-held transceiver while power to your chair is on. Use extra care if you believe that such a device may be in use near your chair.
2. Be aware of nearby radio or TV stations, and avoid coming close to them.
3. If unintended movement occurs, turn your chair off as soon as it is safe to do so.

A. WHAT IS EMI?

⚠ WARNING

1. EMI means: electromagnetic (EM) interference (I). EMI comes from radio wave sources such as radio transmitters and transceivers. (A “transceiver” is a device that both sends and receives radio wave signals).
2. There are a number of sources of intense EMI in your daily environment. Some of these are obvious and easy to avoid. Others are not, and you may not be able to avoid them.
3. Powered wheelchairs may be susceptible to electromagnetic interference (EMI) emitted from sources such as radio stations, TV stations, amateur radio (HAM) transmitters, two way radios, and cellular phones.
4. EMI can also be produced by conducted sources or electro-static discharge (ESD).

B. WHAT EFFECT CAN EMI HAVE?

⚠ WARNING

1. EMI can cause your chair, without warning, to:
 - Release its brakes
 - Move by itself
 - Move in unintended directions
 If any of these occurs, it could result in severe injury to you or others.
2. EMI can damage the control system of your chair. This could create a safety hazard, and lead to costly repairs.

C. SOURCES OF EMI

 WARNING

The sources of EMI fall into three broad types:

1. Hand-Held Transceivers:

The antenna is usually mounted directly on the unit. These include:

- Citizens band (CB) radios
- “Walkie-talkies”
- Security, fire and police radios
- Cellular phones
- Lap-top computers with phone or fax
- Other personal communication devices

Note: These devices can transmit signals while they are on, even if not in use.

2. Medium-Range Mobile Transceivers:

These include two-way radios used in police cars, fire trucks, ambulances and taxi cabs. The antenna is usually mounted on the outside of the vehicle.

3. Long-Range Transceivers:

These include commercial radio and TV broadcast antenna towers and amateur (HAM) radios. **Note:** The following are not likely to cause EMI problems: Lap-top computers (without phone or fax), Cordless phones, TV sets or AM/FM radios, CD or tape players.

D. DISTANCE FROM THE SOURCE

 WARNING

EM energy rapidly becomes more intense as you get closer to the source. For this reason, EMI from hand-held devices is of special concern. (See C.1 above) A person using one of these devices can bring high levels of EM energy very close to your chair without you knowing it.

E. IMMUNITY LEVEL

 WARNING

1. The level of EM energy is measured in volts per meter (V/m). Every power wheelchair can resist EMI up to a certain level. This is called its “immunity level”.
2. The higher the immunity level, the less the risk of EMI. It is believed that a 20 V/m immunity level will protect the power wheelchair user from the more common sources of radio waves.
3. The configurations tested and found to be immune to at least 20 V/m are:
Quickie G-424 power wheelchair with a left-hand mounted Penny & Giles Pilot integral controller, Highback contour seat, flip-back armrests, solid flip-up footplate and Gp24 gel cell batteries.
Quickie G-424 power wheelchair with a right-hand mounted QTRONIX remote

joystick system, Highback Contour seat, flip back armrests, solid flip-up footplate and GP24 gel cell batteries.

4. The following specialty import devices have an unknown effect on the immunity level because they have not been tested on the G-424 with the QTRONIX controller:

- Breath Control
- Tri-Switch Head Array
- Heavy Duty Switched Joystick
- Treadle Switch
- Ribbon Switch
- Proximity Head Array
- Zero Touch Switch
- 4-Zero Touch Switch
- 5-Zero Touch Switch
- Disc Switch
- Proportional Head Control
- Proportional Mini-Joystick/Chin Control
- Buddy Button
- Micro Light
- Star Board
- Wafer Board
- Penta Switch
- Plate Switch
- Soft Switch
- Grasp Switch
- Wobble Switch

 WARNING

Individuals with physical limitations requiring the use of a specialty control input device known not to be immune to 20V/m, or not known, should exercise extra care around known sources of EMI.

 WARNING

There is no way to know the effect on EMI if you add accessories or modify this chair. Any change to your chair may increase the risk of EMI. Parts from other suppliers have unknown EMI properties.

F. REPORT ALL SUSPECTED EMI INCIDENTS

 WARNING

You should promptly report any unintended movement or brake release. Be sure to indicate whether there was a radio wave source near your chair at the time. Contact: Sunrise Medical Customer Service Department at (800) 333-4000.

▲ WARNING

Heed all warnings in this section. If you fail to do so a fall, tip-over or loss of control may occur and cause severe injury to you or others.

A. NOTICE TO RIDER

▲ WARNING

1. Before using this chair, you should be trained in its safe use by your health care professional.
2. Every wheelchair is different. Take the time to learn the feel of this chair before you begin riding.
3. Be aware that you must develop your own methods for the safe use of this chair that are best suited to your level of function and ability.
4. Have someone help you practice bending, reaching and transferring until you learn how to do them safely.
5. **Never** try a new maneuver on your own unless you are sure it is safe.
6. Get to know the areas where you plan to use your chair. Look for hazards and learn how to avoid them.

B. NOTICE TO ATTENDANTS

▲ WARNING

Make sure you heed all warnings and follow all instructions in each section of this manual. (Be aware that warnings that apply to the rider also apply to you).

NOTES:

1. You need to work with the rider and the rider's doctor, nurse or therapist, to develop safe methods best suited to your abilities and those of the rider.
2. To manually push the chair you must release the motor locks.
 - Make sure you have full control over the chair when you release the motor locks. When you do so the chair will not have brakes.
3. Propel this chair by the armrest supports only. If using a seat frame, propel the chair by the push handles on the top of the backrest posts. They provide secure points for you to hold the rear of the chair to prevent a fall or tip-over.

C. WEIGHT LIMIT

▲ WARNING

1. Never exceed a total weight of 250 pounds (113.6 kilograms) or 350 pounds (158.8 kilograms) with the heavy duty option, for rider plus items carried.
2. Never use this chair for weight training if the total weight (rider plus additional weights) exceeds 250 pounds (113.6 kilograms) or 350 pounds (158.8 kilograms) with the heavy duty option.
3. Exceeding the weight limit is likely to damage the seat, frame, or fasteners and may cause severe injury to you or others from chair failure.
4. Exceeding the weight limit will void the warranty.

D. CONTROLLER SETTINGS

▲ WARNING

Be aware that you may need to adjust the controller settings of your chair to reduce the risk of a collision, fall or tip-over.

1. Check and adjust the settings every six to twelve months (or more often, if needed).
2. Consult your supplier to adjust the control settings immediately if you notice any change in your ability to:
 - Control the joystick.
 - Hold your torso erect.
 - Avoid running into objects.

E. EMI

▲ WARNING

Read Section V to learn about EMI. To reduce the risk of unintended brake release or chair movement:

1. Never turn on or use a hand-held transceiver while power to your chair is on. Use extra care if you believe that such a device may be in use near your chair.
2. Be aware of nearby radio or TV stations, and avoid coming close to them.
3. If unintended movement or brake release occurs, turn your chair off as soon as it is safe.

F. SAFETY CHECK-LIST

▲ WARNING

Before each use of this chair:

1. Make sure the chair operates smoothly. Check for noise, vibration, or a change in ease of use. (They may indicate low tire pressure, loose fasteners, or damage to your chair).
 - If you detect a problem, make sure to repair or adjust the chair. Deferring repair or adjustment could increase the risk for injury. Your supplier can help you find and correct the problem.
2. Make sure batteries are charged. Green lights on charge indicator will light up when charge is full. Yellow lights indicate battery charge level is getting low. Red lights indicate batteries are in immediate need of charging.

G. CHANGES & ADJUSTMENTS

▲ WARNING

Never use non-Quickie parts or make changes to your chair unless authorized by Sunrise. (Doing so will void the Warranty and may create a safety hazard).

1. If you modify or adjust this chair it may increase the risk of a fall or tip-over.
2. Modifications unauthorized by Sunrise constitutes remanufacturing of the wheelchair. This voids the warranty. The rider then assumes all future liability for the wheelchair.

H. WHEN SEATED IN A PARKED WHEELCHAIR**▲ WARNING**

1. Always **turn off** all power to your chair when you are parked, even for a moment. This will prevent:
 - Accidental movement from contact with the joystick by you or others.
 - Unintended brake release or movement from EMI sources. (See Section V)
2. Make sure that persons who help you (for example, store clerks) are aware of the joystick and do not touch it. If they do, your chair may move suddenly when you do not expect it.

I. ENVIRONMENTAL CONDITIONS**▲ WARNING**

Your chair is not designed for use in a heavy rain storm, or in snowy or icy conditions.

1. Contact with water or excessive moisture can cause an electrical malfunction. The frame, motors and other chair parts are not watertight and may rust or corrode from the inside. To avoid a chair failure:
 - Minimize exposure of your chair to a rain storm or very wet conditions.
 - Never take your chair into a shower, tub, pool or sauna.
 - Do not use your chair in fresh or salt water (such as at the edge of a stream, lake, or ocean).
 - Make sure shroud cover and deck lid are secure.
 - Replace joystick boot if it becomes torn or cracked.
 - Make sure all electrical connections are secure.
 - Dry the chair as soon as you can if it gets wet, or if you use water to clean it.
2. Proceed slowly and use extra care if you must operate your chair on a wet or slick surface.
 - Do so only if you are sure it is safe.
 - Stop if one or both main wheels lose traction. If this occurs, you may lose control of your chair or fall.
 - Never operate your chair on a slope or ramp if there is snow, ice, water or oil film present.
 - When in doubt, have someone help you.
3. When not in use, keep your chair in a clean, dry place.

▲ WARNING

Extra caution should be used when employing the disc switch or the proximity head array as control devices. These two devices are susceptible to malfunction when wet.

J. TERRAIN**▲ WARNING**

1. This chair is designed for use on firm, even surfaces such as concrete, asphalt and indoor flooring.
2. Do not operate your chair in sand, loose soil or over rough terrain. Doing so may damage wheels, bearings, axles or motors, or loosen fasteners.

K. STREET USE**▲ WARNING**

In most states, power chairs are not legal for use on public roads. Be alert to the danger of motor vehicles on roads or in parking lots.

1. At night, or when it is hard to see, use reflective tape on your chair and clothing.
2. It may be hard for drivers to see you. Make eye contact with drivers before you proceed. When in doubt, yield until you are sure it is safe.

L. MOTOR VEHICLE SAFETY**▲ WARNING**

To date, the U.S. Department of Transportation has not approved any tie down system for transporting a wheelchair in a motor vehicle.

1. Never sit in this chair while in a moving vehicle. In an accident or sudden stop you may be thrown from the chair.
 - **Wheelchair belts are designed to position the rider only and will not protect you in an accident; further injury may result from the belts.**
2. Always move to an approved vehicle seat. You must be secured with proper motor vehicle restraints.
3. Never transport this chair in the front seat of a vehicle. It may shift and interfere with the driver.
4. Always secure this chair so that it cannot roll or shift.

M. CENTER OF BALANCE**▲ WARNING**

The point where this chair will tip forward, back or to the side depends on its center of balance and stability.

THE CENTER OF BALANCE IS AFFECTED BY:

1. The seat height and seat angle.
2. A change in your body position, posture or weight distribution.
3. Using this chair on a ramp or slope.
4. The use of a back pack or other options, and the amount of added weight.

TO REDUCE THE RISK OF A FALL OR TIP-OVER:

1. Consult your supplier for information on modifications authorized by Sunrise before you modify or adjust this chair.
 - Note:** You may need to make additional changes to correct the center of balance.
2. Use extreme care until you know the balance points of this chair and how to avoid a fall or tip-over.

N. TRANSFERS **WARNING**

It is dangerous to transfer on your own. It requires good balance and agility. Be aware that there is a point during every transfer when the wheelchair seat is not below you. To avoid a fall:

1. Always turn off power before you transfer to or from your chair. If you fail to do so you may touch the joystick and cause your chair to move when you do not expect it.
2. Make sure motor locks are engaged. This keeps the chair from moving when you transfer.
3. Work with your health care professional to learn safe methods.
 - Learn how to position your body and how to support yourself during a transfer.
 - Have someone help you until you are sure you can do a safe transfer on your own.
4. Move your chair as close as you can to the seat you are transferring to. If possible, use a transfer board.
5. Rotate the front casters until they are as far forward as possible.
6. Be careful of the foot platform. If you can, remove or swing it out of the way.
 - Never stand on footrests when you transfer. Doing so may damage them or cause your chair to tip.
 - Make sure your feet do not “hang up” or get caught in the space between the footrests.
7. Make sure armrests do not interfere.
8. Transfer as far back onto the seat surface as you can. This will reduce the risk that you will miss the seat or fall.

O. REACHING OR LEANING **WARNING**

Reaching or leaning affects the center of balance of your chair. If done improperly, a fall or tip-over is likely. When in doubt, ask for help or use a device to extend your reach.

TO REDUCE THE RISK OF INJURY AND/OR DAMAGE TO THE CHAIR:

1. Never reach or lean if you must shift your weight sideways or rise up off the seat.
2. Never reach or lean if you must move forward in your seat to do so. Always keep your buttocks in contact with the backrest.
3. Never reach with both hands (you may not be able to catch yourself to prevent a fall if you lose your balance).
4. Never try to pick up an object from the floor by reaching down between your knees.
5. Never put pressure on the foot platform while reaching. This may cause the chair to tip if you lean too far.
6. Never reach or lean over the top of the seat back. This may damage the backrest and cause you to fall.

IF YOU MUST REACH OR LEAN, DO SO AT YOUR OWN RISK.**Remember to:**

1. Move your chair as close as you can to the object you wish to reach.
2. Rotate the front casters until they are as far forward as possible. This makes the chair more stable.

Note: To do this: Move your chair past the object you want to reach, then back up alongside it. Backing up will rotate the casters forward.
3. Turn off all power to your chair. If you fail to do so, you may touch the joystick and cause your chair to move when you do not expect it.
4. Firmly grasp an armrest with one hand. This will help to prevent a fall if the chair tips.

P. DRESSING OR CHANGING CLOTHES **WARNING**

Be aware that your weight will shift if you dress or change clothes while seated in this chair. To make the chair more stable, rotate the front casters until they are **forward**.

Q. OBSTACLES

▲ WARNING

Obstacles you may have to overcome in daily use include door thresholds, lifts, ramps and hazards such as potholes and broken pavement. These can damage your chair and may cause a fall, tip-over or loss of control.

1. Be aware that thresholds are very dangerous. (Even a small change in height may stop a caster wheel and cause your chair to tip). You may need to:
 - Remove or cover threshold strips between rooms.
 - Install a ramp at entry or exit doors.
2. Keep your eyes moving when you ride; scan the area well ahead of your chair.
3. Make sure the floor areas where you use this chair are level and free of obstacles.
4. To help correct your center of balance:
 - Lean your upper body **forward** slightly as you go **up** over an obstacle.
 - Press your upper body **backward** as you go **down** from a higher to a lower level.

R. DRIVING IN REVERSE

▲ WARNING

Use extra care when you drive your chair in reverse. You may lose control or fall if one of the rear wheels hits an object.

1. Operate your chair slowly and at an even speed.
2. Stop often and check to make sure your path is clear of obstacles.

S. RAMPS, SLOPES & SIDEHILLS

▲ WARNING

The center of balance of your chair changes when you are on a slope.

Note: "Slope" includes a ramp or sidehill. Your chair is less stable when it is at an angle. Never use this chair on a slope unless you are sure it is safe.

When in doubt, have someone help you.

Beware Of:

1. Steep slopes. Do Not use this chair on a slope steeper than 10%. (A 10% slope means: One foot in elevation for every ten feet of slope length).
2. Wet or slippery surfaces (such as when ice, snow, water or oil film is present). A loss of traction may cause a fall or tip-over.
3. A change in grade on a slope (or a lip, bump or depression). These may cause a fall or tip-over.
4. A drop-off at the bottom of a slope. (A drop-off of as small as 3/4 inch can stop a front caster and cause the chair to tip forward).

T. TO REDUCE THE RISK OF A FALL, TIP-OVER OR LOSS OF CONTROL:

▲ WARNING

1. Never use your chair on a slope unless you are sure you can do so without losing traction.
2. Always go as straight up and as straight down as you can.
 - Do not "cut the corner" on a slope or ramp.
 - Do not turn or change direction on a slope.
3. Always stay in the center of the ramp. Make sure ramp is wide enough that you are not at risk that a wheel may roll off the side.
4. Lean or press your body uphill. This will help adjust for a change in the center of balance caused by the slope. (Figure 1)
5. Keep your chair moving at a slow, steady speed. Keep control over the chair at all times.
 - On a descent, do not let your chair accelerate beyond its normal speed.
 - If the chair picks up speed, center the joystick to slow down or stop.

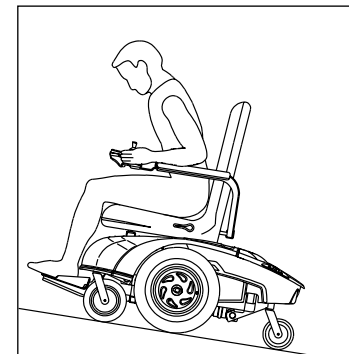

Figure 1

Note: The solid state controller of your chair has a logic system that will help control your speed when driving on a slope or uphill.

- If you stop, re-start slowly.

U. RAMPS AT HOME & WORK

▲ WARNING

Make sure ramps meet all Building Codes for your area.

1. For your safety, have a licensed contractor build or remodel ramp to meet all standards.
2. **Note:** The proper design will vary, depending on such things as: the length and height of the ramp; the need for an intermediate platform; landing size; doors and the direction of swing; and whether the ramp includes a turn or angle.

At A Minimum:

1. Open sides of ramp must have side rails to prevent your chair from going over the edge.
2. Slope must not be steeper than one inch in height for every one foot of slope length.
3. Ramp surface must be even, and have a non-skid surface.
4. You may need to add a section at the top or bottom to avoid a lip or drop-off.
5. Ramp must be sturdy. Add bracing if needed, so ramp does not "bow" when you ride on it.

V. WHEELCHAIR LIFTS

⚠️ WARNING

Wheelchair lifts are used in vans, buses, and buildings to help you move from one level to another.

1. Always turn **off** all power to your chair when you are on a lift. If you fail to do so, you may touch the joystick by accident and cause your chair to drive off the platform. (Be aware that a “roll-stop” at the end of the platform may not prevent this).
2. Make sure there is not a lip or drop-off at the top or bottom of the platform. These may cause a fall or tip-over. When in doubt, have someone help you.
3. Always secure the rider with a positioning belt to help prevent falls during transfers.
4. Avoid moving forward if a wheel is “hung up” on the lip of the ramp. Backup, reposition the caster for a more direct approach and slowly try again.

W. CURBS & SINGLE STEPS

⚠️ WARNING

1. Your chair is not designed to drive up or down a curb or step more than two (2) inches high. Doing so may:
 - Result in a fall or tip-over.
 - Damage the frame, wheels, axles or other chair parts, or loosen fasteners.
2. To prevent a fall or tip-over, use wheelchair access ramps or have someone help you.
3. If you must climb or descend a curb or step alone do so at your own risk and use extreme care.
 - Go as straight up or straight down as you can. **Never** turn or climb or descend at an angle as a fall or tip-over is likely.
 - Proceed slowly, at a steady speed.
4. Make sure that persons who assist you review the “Tips For Attendants” and heed all warnings.

X. STAIRS

⚠️ WARNING

Never use this chair to go up or down stairs, even with an attendant. Doing so is likely to cause a fall or tip-over.

Y. ESCALATORS

⚠️ WARNING

Never take this chair on an escalator, even with an attendant. Doing so is likely to cause a fall or tip-over.

⚠️ WARNING

Note: If you use parts or make changes not authorized by Sunrise it may create a safety hazard and will void the Warranty.

A. ARMRESTS

⚠️ WARNING

Armrests flip back and cannot be used to lift chair or the seat.

1. **Never** lift this chair by its armrests.
2. Lift this chair only by non-detachable parts of the main frame.

B. BATTERIES

⚠️ WARNING

1. Only **deep cycle sealed case** construction batteries should be used in this device.
2. To prevent an acid spill, always keep batteries **upright**. (wet cell batteries only)
3. **Never** smoke or hold an open flame near batteries. They are a known explosion hazard.
4. Always wear rubber gloves and safety glasses when you handle batteries.
5. Read all of section **XI Batteries** before attempting to change or charge batteries.

C. CUSHIONS

⚠️ WARNING

1. Quickie Contour and Highback Contour seats are designed for comfort, not specifically for the relief of pressure.
2. If you suffer from pressure sores, or if you are at risk that they will occur, you may need a special seat system such as can be provided by the Seat Frame, or a device to control your posture.
 - Consult your doctor, nurse or therapist to find out if you need such a device for your well-being.

D. FASTENERS

⚠️ WARNING

Many of the screws, bolts and nuts on this chair are special high-strength fasteners. Use of improper fasteners may cause your chair to fail.

1. **Only** use fasteners provided by Sunrise.
2. If fasteners become loose, tighten them as soon as you can.
3. Over- or under-tightened fasteners may fail or cause damage to chair parts.
 - **See Section IX, “Set-Up, Adjustment & Use”**, for proper torque settings.

E. FOOTPLATE & FOOTRESTS**⚠️ WARNING**

- At the lowest point, the foot platform and footrests should be **at least 2 1/2"** off the ground. If set too LOW, it may "hang up" on obstacles you can expect to find in normal use. This may cause the chair to stop suddenly and tip forward.
- To avoid a trip or fall when you transfer:
 - Make sure your feet do not "hang up" or get caught in the space surrounding or in between the footrests.
 - Avoid putting weight on the footplate or footrests, as the chair may tip forward.
 - Flip the footplate back or swing the footrests out of the way, if possible.
- Never** lift this chair by the footplate or footrests. Footrests fold or detach and will not bear the weight of this chair. Lift this chair only by non-detachable parts of the main frame.

F. MOTOR LOCKS**⚠️ WARNING**

- Do not engage or disengage motor locks **unless** power to the chair is **off**.
- With either one or both brakes released, the chair will not operate, and the battery charge indicator will flash 9 bars rapidly (if power to the chair is on).
- Be aware that the chair **will not have brakes** when motor locks are in the free-wheel position.
- Make sure that the person pushing the chair has full control when motor locks are disengaged.

G. ON/OFF SWITCH**⚠️ WARNING**

- Never** use the ON/OFF switch to stop the chair **except** in an emergency. This will result in an **abrupt** stop and may cause you to fall.
- To slow your chair to a stop, return the joystick to neutral.

H. PNEUMATIC TIRES**⚠️ WARNING**

Proper inflation extends the life of your tires and makes your chair easier to use.

- Do not use this chair if any of the tires are under- or over-inflated. Check weekly for proper inflation level, as listed on the tire sidewall.
- Low pressure in a tire may cause the chair to veer to one side and result in a loss of control.
- An over-inflated tire may burst.

- Never** use a gas station air pump to inflate a tire. Such pumps provide air at **high volume**, and could cause the tire to burst. To prevent tire damage:
 - Use a hand pump (or a **low volume** air pump) to inflate tires.
 - Use a tire gauge to check pressure.
- Driving over sharp objects may cause damage to pneumatic tires and tubes.

I. POSITIONING BELTS (OPTIONAL)**⚠️ WARNING**

Use a positioning belt only to help support your posture. Improper use of such belts may cause severe injury or death.

- Make sure you are not at risk to slide down in the wheelchair seat. If this occurs, you may suffer chest compression or suffocate due to pressure from the belt.
- A pelvic wedge or a similar device can help you from sliding down in the seat. Consult your health care professional to find out if you need such a device.
- The belt must be snug, but must not be so tight that it interferes with breathing. You should be able to slide your open hand, flat, between the belt and your stomach.
- Make sure you can easily remove the belt in an emergency.
- Never** use a positioning belt:
 - In place of a motor vehicle seat belt. In an accident or sudden stop you may be thrown from the chair. A positioning belt will not prevent this, and further injury may result from the belt.
 - As a restraint. A restraint requires a doctor's order.
 - On a rider who is comatose or agitated.

J. PUSH HANDLES (seat frame only)**⚠️ WARNING**

- Push handles provide secure points for an attendant to propel and control the chair. This helps to prevent a fall or tip-over.
- Check to make sure push handle grips will not rotate or slip off.

K. SEATING SYSTEMS**⚠️ WARNING**

- Use of a seating system not approved by Sunrise may alter the center of balance of this chair. This may cause a fall or tip-over.
- Never** change the seating system of your chair **unless** you consult your supplier first.

L. UPHOLSTERY FABRIC**⚠ WARNING**

1. Replace worn or torn fabric of the seat as soon as you can. If you fail to do so, the seat may fail and cause you to fall. Worn fabrics may increase the potential for a fire hazard.
2. Fabric will deteriorate with age and use. Look for fraying, thin spots, or stretching of fabric at rivet holes. Replace fabric as required.
3. Be aware that washing may reduce flame retardation of the fabric.

M. SUSPENSION**⚠ WARNING**

The G-424 suspension system does contain Dry Natural Rubber. The suspension, or any other component on the chair, does not contain any latex based product. The suspension components are enclosed and inaccessible to the user.

⚠ WARNING

1. Persons who help a rider do one of the following tasks should review and heed the warnings “Notice to Attendants” and all warnings in this Manual for that task.
2. The “Tips” that follow are suggestions only. Be aware that you will need to learn safe methods best suited to the rider and to your abilities. Consult your health care professional for instructions.

A. TO CLIMB A CURB OR SINGLE STEP**⚠ WARNING**

The following is one way to safely help a rider climb a curb or single step going **forward**:

1. Stay behind the chair.
2. Face the curb and tilt the chair up on the rear wheels so that the front casters clear the curb or step.
3. Move forward, placing the front casters on the upper level as soon as you are sure they are past the edge.
4. Continue forward until the rear wheels contact the face of the curb or step. Lift and roll the rear wheels to the upper level.

B. TO DESCEND A CURB OR SINGLE STEP**⚠ WARNING**

The following is one way to safely help a rider descend a curb or single step going **backward**:

1. Stay at the rear of the chair.
2. Several feet before you reach the edge of the curb or step, turn the chair around and pull it backward.
3. Proceed carefully. Look over your shoulder and carefully step back until you are off the curb or stair and standing on the lower level.
4. Pull the chair toward you until the rear wheels reach the edge of the curb or step. Then allow the rear wheels to slowly roll down onto the lower level.
5. When the rear wheels are safely on the lower level, tilt the chair back to its balance point. This will lift the front casters off the curb or step.
6. Keep the chair in balance and take small steps backward. Be sure to look where you are going. Turn the chair around and gently lower front casters to the ground.

NOTES:**1. Work Surface For Set-Up:**

Use a flat surface, such as a table, to assemble, adjust and check your chair. This makes the steps easier and helps ensure a correct set-up.

2. Fasteners:

- Many of the screws and bolts on this chair are special high-strength fasteners and may have special coatings.
- Many nuts are of the Nylock type. They have a plastic insert to help prevent loosening.
- **Only** use screws, bolts and nuts provided by Sunrise.

 **WARNING**
1. Use of improper fasteners may cause the chair to fail.**2. Over- or under-tightened fasteners may fail or cause damage to chair parts.****3. If bolts or screws become loose, tighten them as soon as you can. Loose bolts or screws can cause damage to other chair parts causing them to fail.****3. Washers & Spacers:**

- Note the position of washers and spacers before disassembly.
- To avoid damage to the frame, replace all washers and spacers when you reassemble parts.

4. Torque Settings:

- A torque setting is the optimal tightening for a particular fastener. Use a torque wrench that measures inch-pounds to secure screws, nuts and bolts on this chair.

Note: Unless otherwise noted, use a torque setting of 120 inch-pounds for all fasteners.

TOOLS YOU WILL NEED**1. Basic Tool Kit:**

To set-up, adjust and maintain your chair you will need the following tools:

- 7/16" box and open-end wrench
- 1/2" box and open-end wrench
- 3/4" box and open-end wrench
- 3/4" socket wrench
- 5/32" Allen wrench
- 3/16" Allen wrench
- Phillips screwdriver #2
- Custom axle wrench (or a 1/2" open-end wrench)

You can obtain a multi-purpose tool kit from Sunrise, or buy the tools you need from a hardware store.

2. Torque Wrench:

If you plan to adjust and maintain this chair yourself, Sunrise recommends that you use a torque wrench.

Note: The wrench must measure inch-pounds.

You can buy a torque wrench and proper sockets from a hardware store.

CHECK-OUT

Be sure this chair performs to your chosen operational settings. If it does not, turn the chair off immediately and reprogram with the Quickie QTRONIX Programmer. If you do not own a Quickie QTRONIX Programmer have your SUPPLIER reprogram your wheelchair as needed. Or, you can order a Quickie QTRONIX Pad for your own use, from your supplier.

Note: Repeat this procedure until the chair performs to your specifications.

 **WARNING**

When properly set up, this chair will operate smoothly. Check to see that all components work properly. If you detect a problem, be sure to correct it before use.

A. BATTERY REMOVAL

To remove the batteries for transporting or servicing:

I. Remove Batteries

- Lift up deck lid (A).
- Unplug and remove batteries from rear of chair (B).
- Lift up batteries by lifting up on battery straps (C).

II. Alternate Battery Removal

Recommended method for Group 24 batteries.

- Remove seat by removing quick-release pins attaching seat to mount.
- Lift seat off seat mounts.
- Release all release levers (D) on the top of the shroud cover.
- Remove the shroud cover to expose the batteries.
- Unplug and lift up batteries by lifting up on the battery straps.

III. Battery Installation

See *Section XI. Batteries, D* for installation and wiring diagram.

⚠ WARNING

Batteries may weigh up to 55 lbs. Care must be taken to avoid injury when lifting up on battery straps (C).

B. FOOTPLATE HEIGHT ADJUSTMENT**I. Installation**

The single footplate can be adjusted to three different settings. To change the height of the footplate:

- Remove bolt (A)
- Move footplate to desired height
- Re-install bolt (A) through desired hole

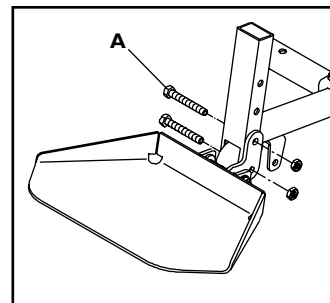
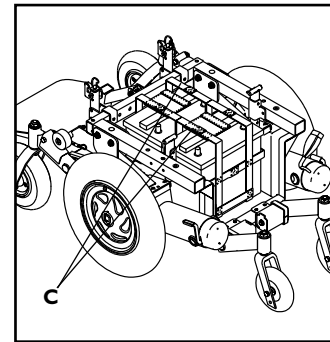
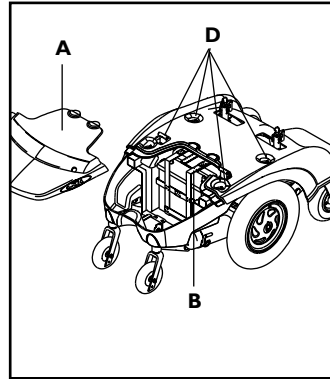
**C. SWING-AWAY FOOTRESTS****I. Installation**

- Place swing-away pivot pin (A) into the locating hole (B) on top of the hanger mount with the footrest facing outward from frame.
- Rotate the footrest inward until latch plate locks into place on locking bolt.

2. Removal

- To remove footrest, press quick-release lever (C).
- Rotate footrest outward and lift.

3. Height Adjustment

- Remove bolts (D) and washer from the hanger tube.
- Reposition footplate by aligning holes and reinstalling bolts (D). Additional range available with other length extension tubes.

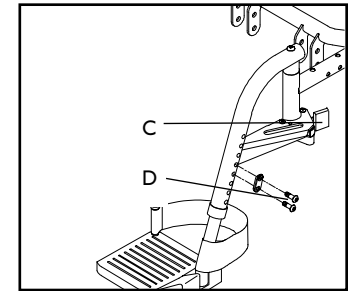
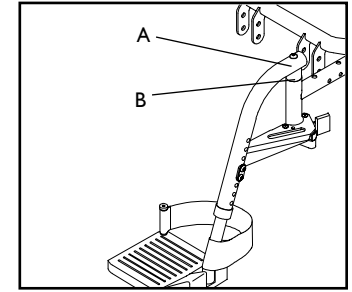
**D. ELEVATING LEGREST (OPTIONAL)****I. Installation**

To install or remove Elevating Legrest (ELR) see instructions for Swing-away Footrest installation above.

2. Adjustment

- To raise legrest, lift to desired position. Legrest will automatically lock in place.
- To lower legrest, while seated in chair, first lift slightly, then press release lever (E) up and lower legrest to desired position.

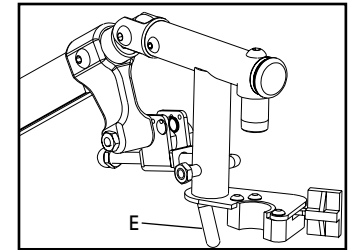
**E. INTEGRAL JOYSTICK****I. To Connect**

- Line up receptacle on large rectangular connector (Beau Connector) located behind the seat with the pins on the connector located on the joystick harness.
- Push in firmly.

2. To Disconnect

Pull up on connector until it disconnects from the frame mounted receptacle, located behind the seat.

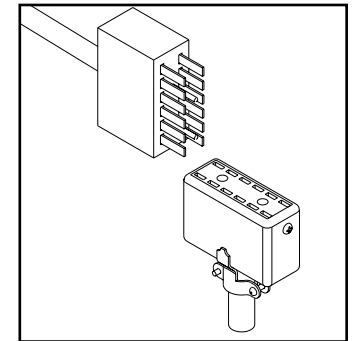

F. REMOTE JOYSTICK INSTALLATION

1. To Connect

- Line up female cylindrical connector (C) with its male receptacle on the end of the power cable (D).
- Push in firmly.

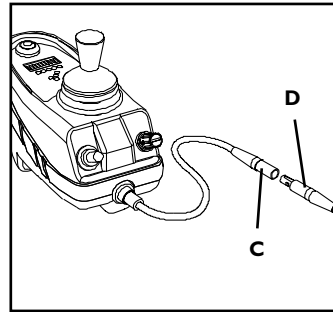

2. To disconnect

Pull back on the retaining ring of the cylindrical connector (C) until it disconnects from the power cable (D).

G. TO ADJUST THE HEIGHT OF THE REMOTE JOYSTICK

- Remove the two pan-head screws (A), securing the angle bracket mount (B).
- Remove the joystick from the mount by unfastening the two screws (C) on the underside of the mount.
- Position angle bracket mount such that you achieve the desired joystick height. Four positions are available by relocating the mount either on the top or bottom of the mounting bar (D) and/or by rotation of the angle bracket mount.

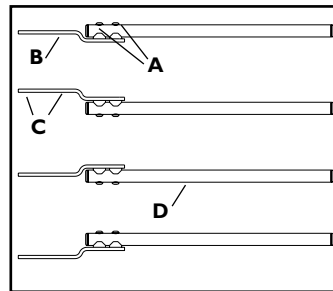

H. REMOTE JOYSTICK SWING-AWAY RETRACTABLE MOUNT (OPTIONAL)

The joystick is mounted with a mechanism which allows the control to be locked in a forward or retracted position.

1. Adjustment

- To retract joystick, press firmly on inside of joystick (E).
- Push joystick away from front of armrest until it locks into retracted position.
- To return to forward position, pull to release magnetic catch and swing.
- Tension adjustment can be made by tightening through bolt (F).

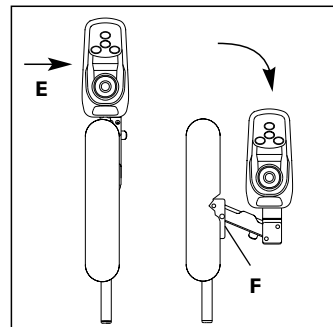

I. FLIP BACK WIDTH ADJUSTABLE ARMRESTS (CONTOUR & HIGH BACK CONTOUR SEAT)

1. Installation/Removal or Adjustment

- Insert armrest support (A) inside of 1" square tube (B) located on back of the seat.
- Repeat for other side of seat.
- Position armrest at appropriate width.
- Tighten set screws (C) on square tube using allen wrench.

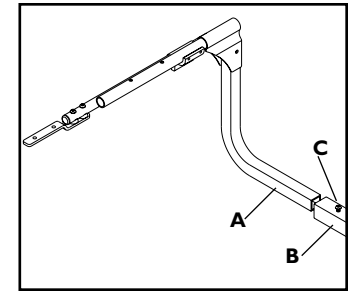

J. ANGLE ADJUSTMENT ARMRESTS

1. Adjustment

- Flip back armrest.
- Adjust the angle of the armrest by turning the bolt (D) clockwise to reduce the angle and counter clockwise to increase the angle.
- Fully tighten the jam nut.

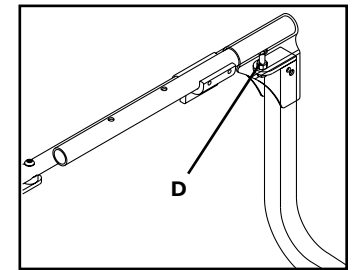

K. DUAL-POST HEIGHT-ADJUSTABLE FLIP-BACK ARMRESTS (SEAT FRAME ONLY)

The dual-post flip-back armrest can be used as either a flip-back armrest or a removable armrest.

1. Installing Armrest

- Flip levers A and B to open receivers.
- Insert front and rear armrest posts into receivers.
- Flip levers A and B to engage.

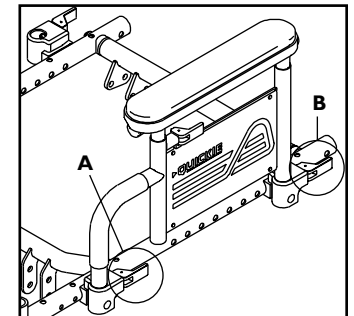

2. Set-up for Flip-back Operation

- Flip lever A so front post is able to lift free.
- Armrest now has the ability to be flipped back without removal.

3. Set-up for Removal

- Flip levers A and B so front and rear posts are able to lift out freely.
- Armrest can now be easily removed for transferring.

4. Height-Adjustment

- Release the upper securing lever (C).
- Set at desired height
- Return securing lever to locked position.
- Move armrest up or down to allow armrest to snap into place.

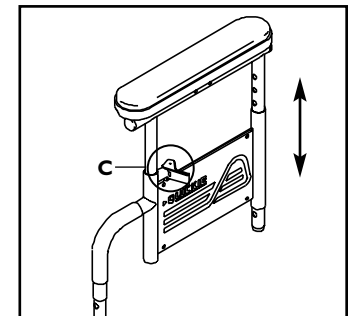

L. BACKREST

A backrest angle-adjustment is standard on the Contour seat, the Highback Contour seat, and the Seat Frame.

1. Seat Depth and Angle Adjustment on Seat Frame

- Remove the front securing bolt (C) on the side of the backrest hinge plate.
- Loosen the lower rear bolt (D)
- Set at desired angle. There are four holes (in 4° increments) to choose from.
- Reinstall the front bolt (C) and tighten both bolts securely.

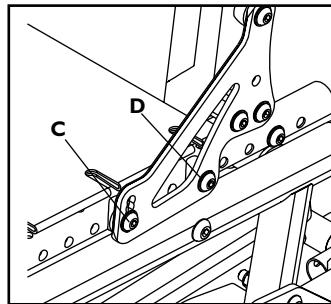
**2. Seat Depth and Angle Adjustment on the Contour Seat**

- The contour seat is shipped with a seat-to-back angle of 100° and a back height of 18"
- To increase the seat-to-back angle, adjust stop bolt (E) to desired location. Do the same for the other hinge.
- To decrease the back height, remove hinge bolt from hole (F) and replace bolt in hole (G). Do the same for the other hinge.

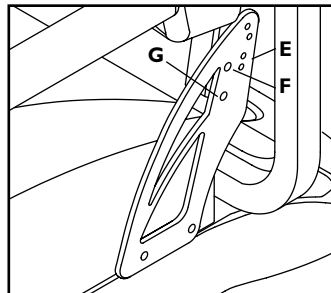

Note: Adjusting the back height will change the seat-to-back angle. Follow instructions to adjust the seat-to-back angle accordingly.

Note: Adjustment on both sides of the wheelchair must be equal.

⚠ WARNING**3. Adjustment for the Highback Contour Seat**

- Pull lever (H) upwards.
- Lean back to desired position.
- Release lever (H).

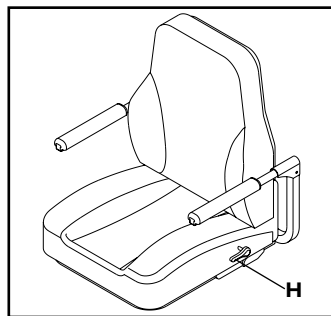

CAUTION: Backrest latches must be locked into place before operating wheelchair.

M. FOLDING BACKREST (seat frame & Contour seat only)

Quickie G-424 wheelchairs are shipped with backrest in folded position.

1. Upright Contour Seat Positioning

- Lift backrest to upright position.

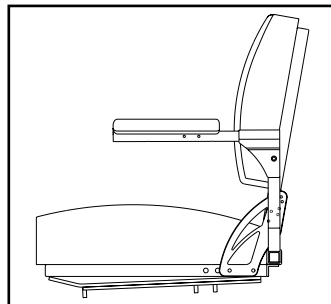

- Backrest is ready for use.

2. Folding Backrest

- Fold backrest forward.

N. FOLDING BACKREST (SEAT FRAME)

Folding backrests are shipped with backrest in folded position.

1. Upright Positioning

- Lift backrest to upright position so that latch handles (F) lock into place.
- Backrest is ready for use.

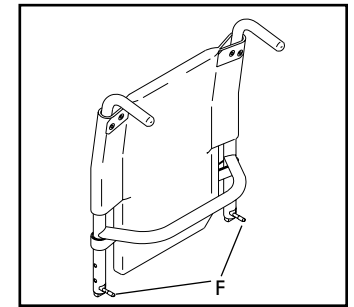
**2. Folding Backrest**

- Lift and turn backrest latch handles (F) inward or outward.
- Fold backrest forward.

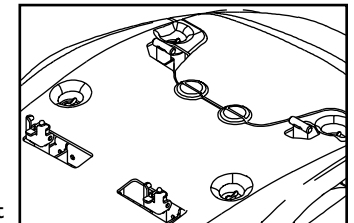
**O. SEAT HEIGHT ADJUSTMENT****1. Contour and Highback Contour Seats**

The seat height can be adjusted for different seat heights.

- Remove the seat and shroud cover. For instructions on removing seat, see section IX, P. For instructions on removing shroud, see section IX, Q.
- Reposition all four of the seat mounts to desired position by removing bolts, adjusting mounts and replacing bolts.
- Ensure that the top of all seat mounts sit at the same height.
- Replace shroud and seat.

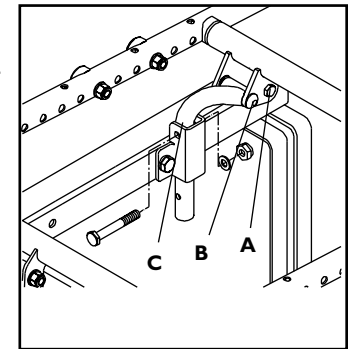
**2. Seat Frame Height Adjustment**

Adjusting the seat height can be done both at the front and at the rear of the seat. Seat angle can also be achieved through front and rear seat adjustment.

Rear Seat Height Adjustment

- Use positioning holes (A&B) and receiver notch (C).

Front Seat Height Adjustment

- Use positioning holes (I, II, i, ii) to adjust height.

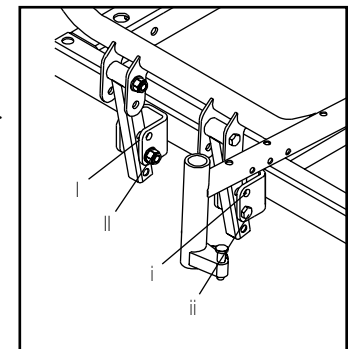

P. SEAT REMOVAL (CONTOUR & HIGHBACK CONTOUR SEATS)**1. Remove Seat**

- Remove safety lock-out pin (A).
- Pull down both the right and left release buttons.
- Flip seat back and remove.

2. Replace Seat

- Position rear of seat on docking mount.
- Rotate seat forward until latches lock the seat in place.
- Replace the safety lock-out pin under the left release lever.

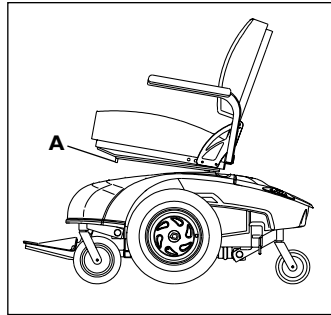
**⚠ WARNING**

Always replace the safety lock-out pin to prevent inadvertent release of the seat.

Q. SHROUD REMOVAL

The plastic protective shroud can be removed for adjustment or servicing.

1. Remove Shroud

- Remove deck lid (B). Deck lid is held by two pieces of Velcro and one piece of Poly Lock (plastic locking Velcro).
- Remove four (4) quarter-turn fasteners (C) by turning them 1/4 turn and removing.
- Lift shroud from a central point.

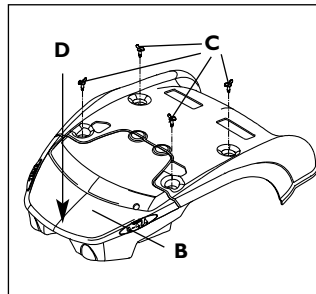
**2. Replace Shroud**

- Replace shroud by repositioning shroud on base frame and align the holes with the frame fasteners.
- Secure 1/4 turn fasteners.
- Install deck lid and press firmly with thumb at D using support with your forefingers in pocketed area under lid.

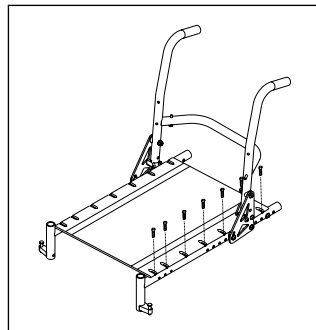
**R. PARAPAK SEAT SLING (SEAT FRAME)**

The seat sling tension can be adjusted through use of the VELCRO® retaining material beneath the seat.

1. Adjustment

- Remove the screws retaining the left side seat sling.
- Readjust VELCRO® style material to increase the tension in the seat sling.

- Replace screws and tighten.

Important Note: If there is any difficulty in re-attaching the screws, try using a probe to help line up the holes.

S. SEAT DEPTH (SEAT FRAME AND CONTOUR SEATS ONLY)

The seat depth can be adjusted in one inch increments.

1. Seat Frame Depth Adjustment

- To adjust, remove the two bolts (A) from each side of the backrest pivot plate.
- Reposition the backrest to the desired position.
- Replace and retighten bolts on each side of the backrest pivot plate.

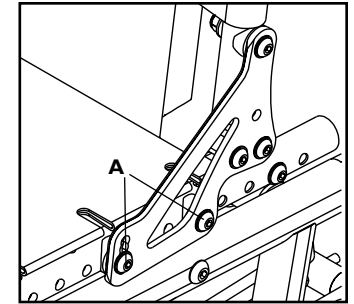
**2. Contour Seat Depth Adjustment**

- Remove bolts (B) on the seat hingeplate.
- Adjust the set back to desired position.
- Refasten bolts (B) in appropriate location.

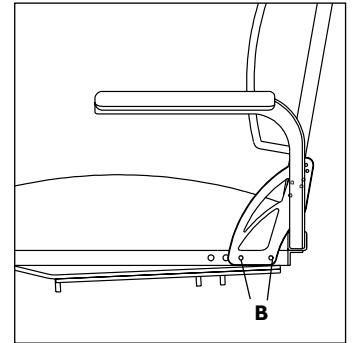
**T. CHECK-OUT**

Once the wheelchair is assembled and adjusted, it should roll smoothly and easily. All accessories should also perform smoothly.

After the wheelchair has been set up be sure the chair performs to your specified operational settings (see pages 36-39). If the chair does not perform to specifications, turn the wheelchair OFF immediately and reprogram operational specifications using the QTRONIX Programming Pad.

Repeat this procedure until the wheelchair performs to specifications before attempting active use of the wheelchair.

If you have any problems, follow these procedures:

- Review the Set-up, Adjustment & Use section and Operating Guide to make sure chair was properly prepared.**
- If your problem persists, contact your authorized supplier. If you still have a problem after contacting your authorized supplier, contact Sunrise customer service. See the introduction page for details on how to contact your authorized supplier or Sunrise customer service.**

A. PERFORMANCE CONTROL SETTINGS

1. It is vital to match control settings to your level of function and ability.
2. Consult your health care professional and your supplier to select the best control settings for you.
3. Check and adjust the settings every six to twelve months (or more often, if needed).
4. Adjust the control settings **immediately** if you notice any change in your ability to:
 - Control the joystick.
 - Hold your torso erect.
 - Avoid running into objects.
5. Control Settings are adjusted through the use of the Quickie QTRONIX Programming Pad. See your supplier if you do not own a Quickie QTRONIX Programming Pad.

B. QUICKIE QTRONIX PROGRAMMER PAD (OPTIONAL)

⚠ WARNING

Program settings beyond the ability of the rider can result in serious injury. Consult your health care advisor before you alter settings.

1. Notes:

The Quickie QTRONIX Programmer lets you adjust the performance control settings of the G-424. You can customize a program for yourself or select the standard program.

- acceleration rate
- deceleration rate
- turn acceleration
- turn deceleration
- forward speed (max & min)
- reverse speed (max & min)
- turn speed (max & min)
- steer correct

Remote systems

- 4-axis joystick throw
- sleep timer
- profile number
- read timer

2. To Program Your Chair:

- a. Turn **off** power to the chair.
- b. Insert Quickie QTRONIX Programmer plug (A) into the programmer/charger socket on the front of the joystick.

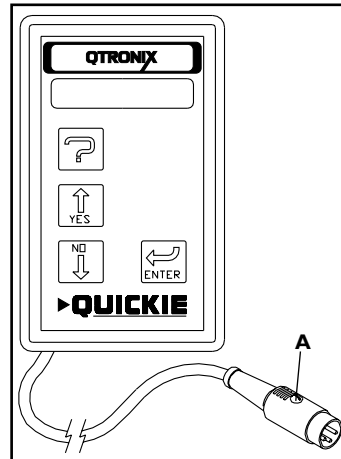

- c. Turn **on** power to the chair; program as needed.
- d. Remove plug and cycle ON/OFF switch to drive chair.

Note: Review the Quickie QTRONIX Programmer Owner's Manual for more details on how to program your chair.

Note: Program settings that are not matched for the capabilities of the rider can result in serious injury. Do not alter settings without the advice of your health care professional.

C. THERMAL ROLL-BACK

Your chair has a thermal roll back circuit. This protects the controller from damage due to overheating. In extreme conditions (such as repetitive hill climbing) the circuit will decrease the power to your motors. This allows the chair to operate at a reduced speed. When the controller cools, the chair will return to normal speed.

D. CIRCUIT BREAKERS

1. Notes:

Your Quickie G-424 has a circuit breaker protruding through the shroud cover at the right rear of the chair.

- In the unlikely event of a short circuit or heavy overload, all power to your chair will be shut off.
- To reset your chair, depress the circuit breaker button located at the rear corner of the chair. A few minutes wait is required before the circuit breaker will reset.

2. Repeated Shutdown:

If the chair continues to shut down after resetting, have it serviced by a supplier.

E. INTEGRAL JOYSTICK

The standard integral joystick controls the chair's performance. It consists of the following parts:

1. Speed Control or Drive Mode Selection Buttons (A and B)

To decrease the speed level depress button A. Or, when 1- 5 Drive modes are programmed, depress button A to activate lower drive mode(s).

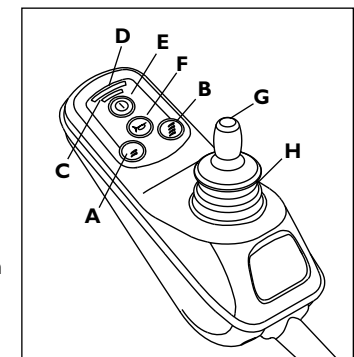
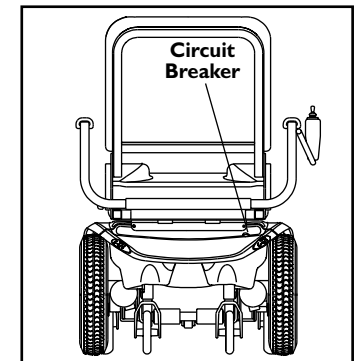

Integral Joystick

To increase speed level, depress button B. Or, when 1- 5 Drive modes are programmed, depress button B to activate higher drive mode(s).

Speed level active, or Drive Mode selected, is indicated on display (C) by a series of five lights. One light indicates slowest level/mode currently active, while five lights indicates highest level/mode currently active.

2. Battery Charge Indicator (D)

- Green lights indicate that batteries are fully charged.
- Yellow lights indicate that batteries need recharging.
- When the lights stay in the red band, the batteries must be recharged.

3. On/Off Button (E)

Turning the chair on or off is accomplished by depressing button E.

4. Horn (F)

5. Joystick (G)

The joystick controls the direction and speed of your chair. Turn the chair on and move the joystick in the direction you want to go.

- Moving the joystick from the neutral (center) position disengages the motor locks, allowing the chair to move.
- The chair will move faster the more you move the joystick away from neutral.

NOTE– If your speed becomes hard to manage, release the Joystick and the chair will come to a complete stop.

- When you release the joystick it will return to neutral; the chair will slow to a stop and the motor locks will reengage.
- We recommend that you switch the chair off if you stop for any length of time. This will conserve battery power.

NOTE– Once the chair stops, switching the chair off will not affect the motor locks.

6. Joystick Boot (H)

Make sure the boot is not torn or cracked (this could allow debris, water or moisture to enter). If the boot is torn or cracked, replace it as soon as you can.

F. REMOTE JOYSTICK ASSEMBLY (OPTIONAL)

The remote joystick connects to a controller, which controls the chair's performance. The joystick assembly consists of the following parts:

1. Speed Control Knob (D)

Use the speed control knob to adjust the maximum speed of your chair. Turn it counter-clockwise to reduce speed; turn it clockwise to increase speed.

2. Battery Charge Indicator (B)

- Green lights indicate that batteries are fully charged.
- Yellow lights indicate that batteries need recharging.
- When the lights stay in the red band, the batteries must be recharged.

3. On/Off Mode switch (A)

The on/off mode switch is located on the rear face of the joystick housing. It is a toggle switch. Turning the chair on or off, is accomplished by pressing the switch downward. The switch will automatically return to the center point. Alternate locations exist for this switch. Please see your supplier in the event that you wish to relocate or re-orient this switch.

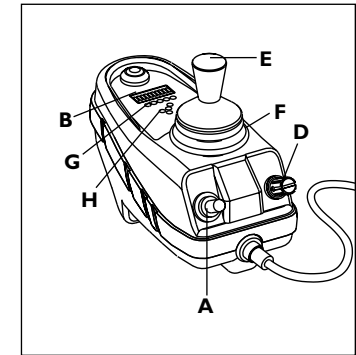

Remote Joystick (Optional)

4. Mode Switch (A)

The on/off mode switch allows you to select from 5 (five) different programmable drive profiles or actuator mode sets.

- Push up the on/off mode select toggle switch to index among the five drive and actuator modes. The selected mode indicator will flash.
- Push joystick either left or right to select one of the five drive profiles. To select the actuator modes, push up on the mode select switch twice.
- The drive profiles are indicated by the mode indicators (G) and the actuators are indicated by the four actuator lights (H).
- To exit drive or actuator mode select, simply push the on/off/mode toggle up one or more times until the indicator no longer flashes, or push the joystick forward or reverse to begin driving.

5. Joystick (E)

The joystick controls the direction and speed of your chair. Turn the chair on and move the joystick in the direction you want to go.

- Moving the joystick from the neutral (center) position disengages the motor locks, allowing the chair to move.
- The chair will move faster the more you move the joystick away from neutral.

NOTE– If your speed becomes hard to manage, release the Joystick and the chair will come to a complete stop.

- When you release the joystick it will return to neutral; the chair will slow to a stop and the motor locks will reengage.
- We recommend that you switch the chair off if you stop for any length of time. This will conserve battery power.

NOTE– Once the chair stops, switching the chair off will not affect the motor locks.

6. Joystick Boot (F)

Make sure the boot is not torn or cracked (this could allow debris, water or moisture to enter). If the boot is torn or cracked, replace it as soon as you can.

7. Remote Switch Jacks (optional– not shown)

Two 1/8" switch jacks are optional to provide remote switch control of the on/off power function and the mode select function. Any of the single switches offered by Sunrise Medical can be used to connect to either or both of these jacks (except the single zero touch switch).

⚠ WARNING

1. **Never use the ON/OFF switch to stop your chair except in an emergency. This will result in an abrupt stop, and may cause you to fall.**
2. **To slow or stop your chair, return the joystick to neutral.**

G. MOTOR LOCKS

Disconnect the motor locks when you need to manually push the chair. (For example, in an emergency, or if batteries fail).

⚠ WARNING

1. **Do not disengage motor locks unless power to the chair is off.**
2. **With either one or both brakes released, the chair will not operate and the battery charge indicator will flash 9 bars rapidly (if power to the chair is on.)**
3. **Be aware that the chair will not have brakes in the free-wheel position.**
4. **Make sure that the person pushing the chair has full control when motor locks are disengaged.**

1. Release Motor Locks

Push the brake releases upward (A).

2. Engage Motor Locks

Push the brake releases downward (A).

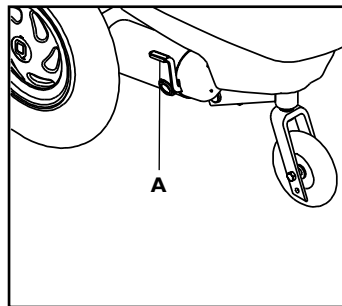

A. INTRODUCTION

1. Notes:

- Batteries supply the power for your chair. They contain a finite amount of energy and have limits on how long they can store and supply energy.
- You can charge batteries only a certain number of times before they will fail and no longer hold a charge.
- For answers to questions about batteries, consult your supplier.

2. Use Proper Batteries:

Your chair operates on two 12 volt batteries.

- They should be GP 24 or 22NF size with a minimum of 40 ampere hour rating. Only **deep cycle sealed case** construction batteries should be used in this device.
- When you buy a replacement, insist on a **deep cycle sealed case**. Do not use a car starter battery.

3. Breaking In:

- A battery requires “breaking-in” for the first 6 to 12 charges. It will not accept a full charge for this period.
- It is best to limit the length of your trips until you break the batteries in and you know the range of your chair.

4. Discharged Batteries:

- **Never** allow a battery to completely discharge. If you operate your wheelchair until it has almost stopped, you will greatly reduce the life of your batteries.
- **Never** let a battery sit in a discharged condition. Give unused or stored batteries a full charge once per month.
- **Always** fully charge the batteries. **Avoid** “topping off” with frequent charges.

⚠ WARNING

Never connect a life support or auxiliary device to a wheelchair battery. The electrical system may fail and result in severe injury to or death of rider.

B. BATTERY CHARGER

A battery charger produces a direct current (DC). When applied to a discharged battery, this reverses the chemical reaction that led to its discharge.

1. Charge Rate. How fast a battery will charge depends on:

- Its electrical capacity, state of charge, electrolyte temperature, and internal condition.
- The DC output of the charger. (The charge rate will vary if the alternating current (AC) supply is higher or lower than 110 volts).

2. Caution — To Avoid Damage to the Charger:

- **Never** place the charger on top of a battery during charging. (Gases from the battery can damage the charger and may lead to an explosion or fire).
- **Never** place a battery on top of the charger.

XI. BATTERIES

- **Never** expose charger to rain or snow.
- **Never** unplug charger by pulling on the electrical cord. This will damage the cord.
- Never open a charger or attempt to repair it yourself. Return charger to Sunrise or have repairs made **only** by a qualified person.
- Keep cord out of the way, where it will not be stepped on, tripped over, or damaged.

3. Caution — To Avoid Damage to the Battery:

- Make sure you use the correct setting for sealed (gel) batteries (located on the off-board charger).
- **Never** charge a frozen battery. A fully charged battery will rarely freeze, but the fluid in a discharged battery can freeze at 16 degrees Fahrenheit (minus 9 degrees Centigrade). If you suspect a battery is frozen, thaw it before charging.

⚠ WARNING

Lead acid batteries generate explosive gas while charging. Completely read and follow all warnings about the batteries in this user instruction manual and any labels applied to the product. Failure to do so could result in fire, explosion, injury and/or death.

C. ACID BURNS (UNSEALED WET CELL BATTERIES)

Acid in batteries is corrosive. If you choose to use wet cell batteries, they can cause serious burns to the eyes and skin and can damage floors, furniture, clothing and your wheelchair.

⚠ WARNING

1. Use extreme care not to spill acid when you handle wet cell batteries. Keep batteries upright.
2. Avoid contact of acid with bare skin or clothing.
3. Always wear rubber gloves and safety glasses when you handle batteries.
4. If acid contacts your skin or clothing, wash immediately with soap and water.
5. If acid contacts your eyes, immediately flood eyes with cold running water for at least 15 minutes. Seek medical attention immediately.

Sunrise Medical does not recommend the use of wet cell batteries on this chair.

D. CONNECTING BATTERIES IN BATTERY WELL

⚠ WARNING

1. Each battery weighs up to 55 lbs. Take care to avoid injury when lifting.
2. Keep batteries upright. Take care not to spill acid (wet cell batteries).
3. Always wear rubber gloves and safety glasses when you handle batteries.
4. Before working around batteries, remove all metal personal effects, such as necklaces, rings, watches, pins, and other metal jewelry that might contact battery terminal and cause a short.

XI. BATTERIES

1. Attach battery harness to battery post.
Connect red to positive terminal and black to negative terminal.
2. Tighten all terminal fasteners using two wrenches.
3. Cover battery posts with insulating caps on harness.
4. Lift batteries into battery well.

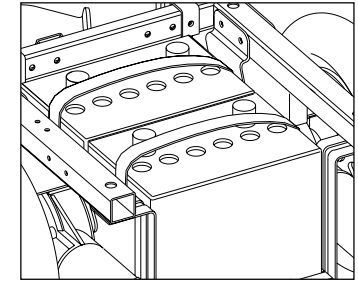

Refer to wiring diagram for battery connections

⚠ WARNING

Batteries weigh up to 55 pounds. Lifting batteries may cause back strain. If you fail to heed these warnings severe injury may occur to you.

5. Plug battery harnesses into chair harness.
6. Place battery access panel, trunk insert and deck lid into position.

⚠ WARNING

Never make direct contact across both battery terminals, as an explosion may occur. A spark may result in an explosion and/or fire resulting in severe injury or death.

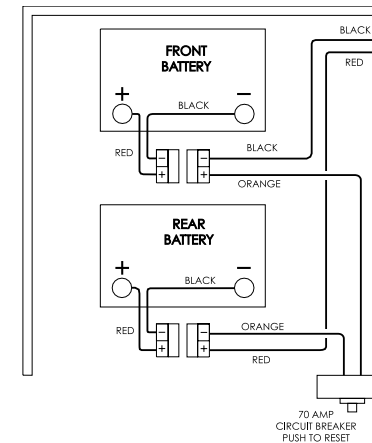

E. CHARGING BATTERIES

⚠ WARNING

To avoid the risk of severe injury or death from electrical shock, fire or explosion while charging:

1. **Never** connect charger to a 240 volt source. The main input voltage is 110 volts.
2. **Never** touch the charger after it is connected to an electrical outlet. This may cause electrical shock.
 - Never connect or disconnect charger from battery while there is power to the charger.

XI. BATTERIES

3. Never use an extension cord. Use of an improper cord could damage the charger or cause a fire or electrical shock.
4. A battery emits explosive hydrogen gas during charging. To reduce the risk of fire or explosion:
 - Make sure area is well vented. Never charge battery in a closed-in area.
 - Never smoke or allow a spark, flame or high heat near battery during charging.
 - Never allow metal tools or chair parts to make direct contact across both battery terminals.
5. Never look directly into cells when charging battery (wet cell batteries).

Always:

1. Use the charger that comes with your wheelchair. Read and follow all instructions and warnings.
2. Make sure room is well ventilated.
3. Turn off all power to your chair.
4. Connect and disconnect battery cables with caution. Only connect the charger to the power supply after the charger has been connected to the chair.
5. Make sure to allow enough time to fully charge batteries.

NOTE: Batteries should never be left for long periods in the discharged state. Unused or stored batteries should be given a charge once per month.

6. Change batteries by engaging the battery charger connector (A) to the charger/programming port (B) located on the joystick.

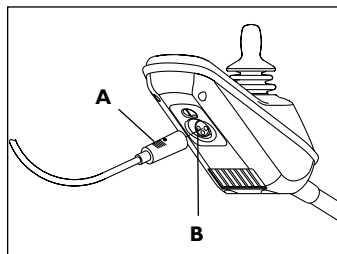

Integral Joystick

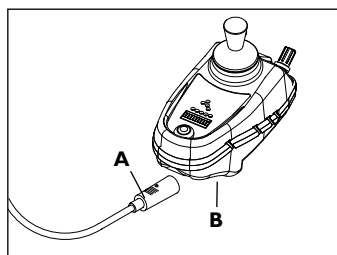

Remote Joystick

F. DISPOSING OF BATTERIES

WARNING

1. All batteries once they have reached the end of their useful life are deemed to be hazardous waste.
2. For further information on handling and recycling contact your local recycling authority.
3. Always dispose of product through a recognized agent.

XII. MAINTENANCE

A. NOTES

1. Proper maintenance will improve performance and extend the useful life of your chair.
2. Clean your chair regularly. This will help you find loose or worn parts and will make your chair easier to use.
3. To protect your investment, have all major service and repair work done by your supplier.

WARNING

1. Your chair needs regular maintenance for peak performance and to avoid injury from chair failure, damage or premature wear.
2. Inspect and maintain this chair strictly per the "Maintenance Chart" (p. 48)
3. If you detect a problem, make sure to service or repair the chair before use.
4. At least once a year, have a complete safety check and service of your chair performed by a supplier.

B. CLEANING

1. Plastic Shroud Cover:

- Clean the plastic finish with mild soapy water monthly.

2. Motors:

- Clean around motor area weekly with a slightly damp (not wet) cloth.
- Wipe off or blow away any fluff, dust, or dirt on or around the motors.
- **Note:** You do not need to grease or oil the chair.

3. Upholstery:

- Hand-wash only as needed. Machine washing may damage fabric (rehab seat only).
- Drip-dry only. Heat from a dryer may damage fabric.

Note: Washing the fabric may decrease fire retardant properties.

C. STORAGE TIPS

1. Store your chair in a clean, dry area. If you fail to do so, parts may rust or corrode.
2. Before using your chair, make sure it is in proper working order. Inspect and service all items on the "Maintenance Chart" (See p. 48).
3. If you store this chair for more than three months, have it inspected by a supplier before use.

D. BATTERY MAINTENANCE

WARNING

1. To prevent an acid spill, always keep batteries upright. (wet cell batteries)
2. Never smoke or hold an open flame near batteries.
3. Always wear rubber gloves and safety glasses when you handle batteries.

1. Maintenance Schedule:

This varies for different types of batteries. Always follow the instructions supplied with your batteries.

Note: Always wear rubber gloves and safety glasses when you handle or service batteries.

2. Adding Water: (Wet Cells Only)

- Wet-type lead acid batteries need periodic replacement of water lost.

Note: use distilled water only.

- Check the battery fluid level about once a week. When you remove the stoppers (on top of the battery) there should be one-eighth to one-quarter of an inch of fluid above the internal plates. Do not overfill.

3. Corrosion:

Check battery terminals often for corrosion.

- If corrosion is present, use a wire brush to clean the terminals.

Note: Always wear safety glasses and rubber gloves.

- Use baking soda to neutralize acid.
- Use petroleum jelly to re-grease the terminals after connecting cables to battery. (Completely cover the terminal nut and bolt, cable clip and any exposed cable with jelly).

4. For Answers To Questions: Contact your supplier.**E. PNEUMATIC TIRES****⚠ WARNING**

1. Do not use this chair if any of the tires are under-inflated or over-inflated.
2. Low pressure in a tire may cause the chair to veer to one side and result in loss of control.
3. An over-inflated tire may burst.
4. Never use a gas station pump to inflate a tire. Such pumps provide air at high volume, and may cause tire to burst.
 1. Check for signs of wear and correct air pressure in pneumatic tires weekly.
 2. For best performance, inflate tires to the same pressure level, as shown on the tire sidewall:
 - 7" pneumatic casters - 30 to 40 psi
 - 14" pneumatic drive wheels - 35 to 45 psi
 3. Caution:

To prevent tire damage:

 - Use a hand pump (or a **low volume** air pump) to inflate tires.
 - Use a tire gauge to check pressure.

F. TO REPAIR OR REPLACE A TIRE**⚠ WARNING**

Residual air pressure in tires can cause severe injury. Make sure you release all air in tire before attempting to service or repair tires.

1. 8" Front Caster Wheels:

- Release all air from tire.
- Remove caster wheel from fork.
- Make sure there is no residual air in tire before you remove bolts that hold the two rim halves together.
- Remove four bolts from rim. Separate two halves of rim.
- Repair or replace inner tube.
- Reassemble the caster wheel; make sure the bearing spacer is in place and all four bolts are secure.

Note: Use a torque setting of 240 inch-pounds when tightening bolts.

- Mount caster wheel onto fork. Install washers correctly.
- Inflate tire to proper pressure level.

2. 14" Drive Wheels:

- Elevate and securely support chair so that wheel is off the ground. Release all air from tire (solid aluminum rim only).
- Remove plastic dome plug.
- Remove lock nut.
- Remove washer.
- Remove wheel from chair.
- Make sure all air has been removed from tube.
- Remove all bolts holding two halves of rim together (not applicable on solid aluminum rim), and remove tire and solid insert.
- Repair or replace inner tube (replace rim strip if necessary).

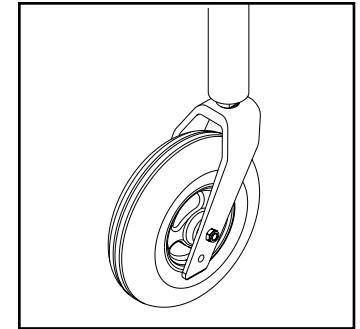

XII. MAINTENANCE

Note: Do not use pneumatic inner tube in tires with two-piece rims.

- i. Reassemble the wheel.
- Use a torque setting of 420 in.-lbs. to re-tighten bolts.**
- j. Install wheel on chair by replacing center lock washer, nut and plastic dome. Use a torque setting of 180 in.-lbs. to retighten bolts.
- k. Inflate tire to proper pressure level (listed on tire sidewall).

G. MOTOR BRUSHES

Check the motor brushes every four (4) months for wear. The brushes should be clean and shiny. Replace worn or blackened brushes.

H. ORDERING PARTS

When you order parts, provide the following:

1. Model of chair
2. Serial number of chair
3. Left hand or right hand control
4. Part number, description and quantity of parts you need.
5. State reason for replacement.

I. MAINTENANCE CHART

You should check the items on this chart at the indicated intervals. If any of the items are loose, worn, bent or distorted, immediately have them checked and/or repaired by your authorized Sunrise supplier. Frequent maintenance and servicing will improve performance and extend wheelchair life, and help prevent injuries.

CHECK...	Daily	Weekly	Monthly	Quarterly	Annually
Charge Batteries	✓				
Check tires for proper inflation level		✓			
Check batteries for proper electrolyte level (wet cell only)		✓			
Check plugs and connectors for proper connections			✓		
Check all moving parts for wear				✓	
Inspect all nuts, bolts and fasteners for looseness or wear				✓	
Inspect upholstery for wear				✓	
Remove and inspect motor brushes				✓	
Servicing by authorized Supplier					✓

XIII. WIRING DIAGRAMS

Wiring Diagram Detail (Remote System)

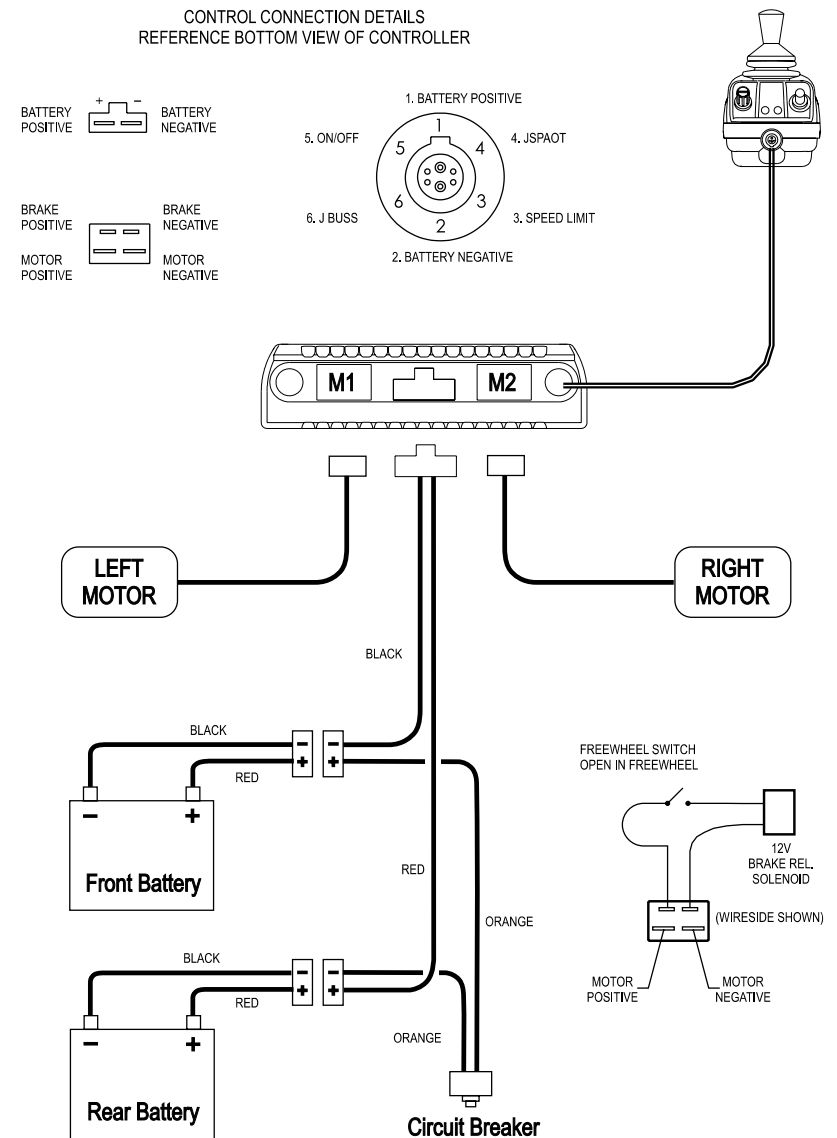

Wiring Diagram Detail (Integrated Control System)

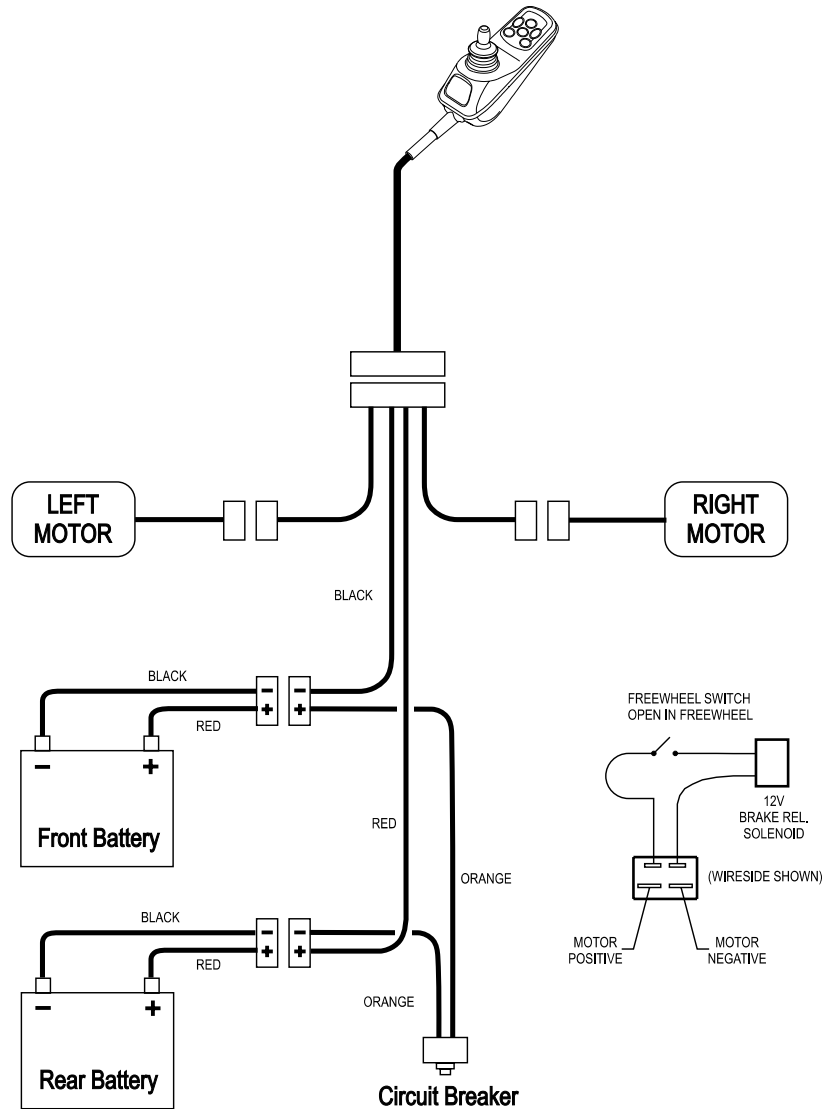

1. FOR LIFE

We warrant the main frame of this wheelchair against defects in materials and workmanship for the lifetime use of the first consumer purchaser.

2. ADDITIONAL WARRANTY

We warrant Sunrise-made components of this wheelchair against defects in materials and workmanship as follows:

- a. Main electronic controller—For two (2) years from the date of first consumer purchase.
- b. Motors, gear boxes and remote joystick—For one (1) year from the date of first consumer purchase.
- c. All other original components (such as wheels, upholstery, plastic, rubber parts and painted surfaces)—For three (3) months from the date of first consumer purchase.

3. LIMITATIONS

- a. We do not warrant damage due to:
 - Neglect, misuse, or improper installation or repair.
 - Use of parts or changes not authorized by Sunrise.
 - Exceeding the weight limit of 250 pounds or 350 lbs for the heavy duty package.
- b. This warranty is **void** if the original chair serial number tag is removed or altered.
- c. This warranty applies in the USA **only**. Check with your supplier to find out if international warranties apply.

4. WHAT WE WILL DO

Our sole liability is to repair or replace covered parts. This is your **only** remedy for consequential damages.

5. WHAT YOU MUST DO

- a. Return the warranty card.
- b. Obtain from us, while this warranty is in effect, prior approval for return or repair of covered parts.
- c. Return the wheelchair or part(s), freight pre-paid, to Sunrise Mobility Products Division at: 2842 Business Park Ave., Fresno, CA 93727-1328.
- d. Pay the cost of labor to install or repair parts.

6. NOTICE TO CONSUMER

There are no other express warranties. To the extent permitted by law, any implied warranty (including a warranty of merchantability or fitness for a particular purpose) is limited to:

- a. One (1) year from the first consumer purchase, and
- b. Repair or replacement of the defective part **only**.

This warranty gives you certain legal rights. You may also have other rights that vary from state to state.



Sunrise Medical Inc.

7477 East Dry Creek Parkway • Longmont, Colorado • 80503 USA

(800) 333-4000

In Canada (800) 263-3390

Manufactured under one or more of the following patents:
U.S. and European patents pending.

© 2002, Sunrise Medical 12.02
930484 Rev. A