

# **PARTS MANUAL**

**Model**

**EX170D50042**

**ENGINE**

PUB-EPMK  
Rev. 11/06

# **Robin America, Inc.**

940 Lively Blvd. • Wood Dale, IL 60191 • Phone: 630-350-8200 • Fax: 630-350-8212  
e-mail: [sales@robinamerica.com](mailto:sales@robinamerica.com) • [www.robinamerica.com](http://www.robinamerica.com)

© Copyright 2006 Robin America, Inc.

## HOW TO USE THIS MANUAL

Robin engines are identified by MODEL, SPECIFICATION, and CODE NUMBER. For each model there may be many different versions called specifications. Each specification will be unique in some way. The difference may only be the paint color or it may have a different type of PTO or some other significant difference.

In order to identify the correct service part number, it is important to confirm the specification and code numbers for your engine. The specification and code number together are known as the PRODUCT NUMBER.

All Robin 4 cycle engines have a Product Number label similar to the label illustrated below.

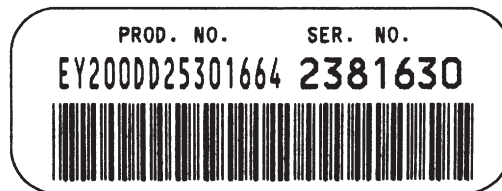
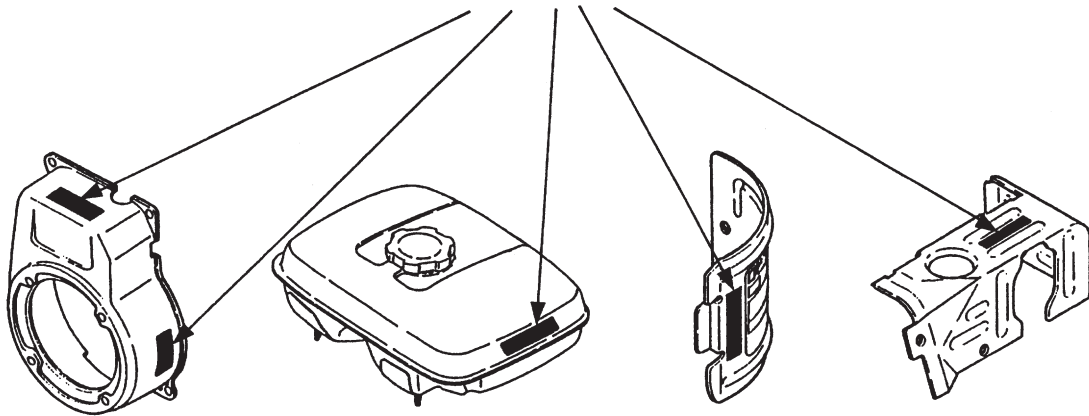

The Product Number Label has a 15 digit alphanumeric string that consists of the SPECIFICATION (SPEC) number (11 digits) and the CODE number (4 digits). Please note the illustration below:

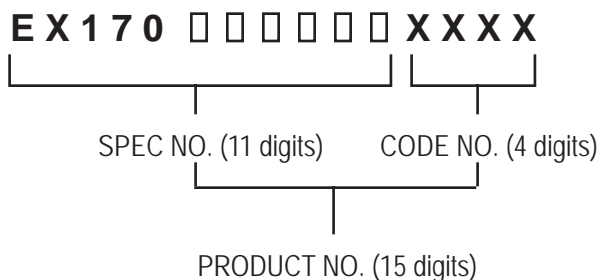

# MANUAL LAYOUT

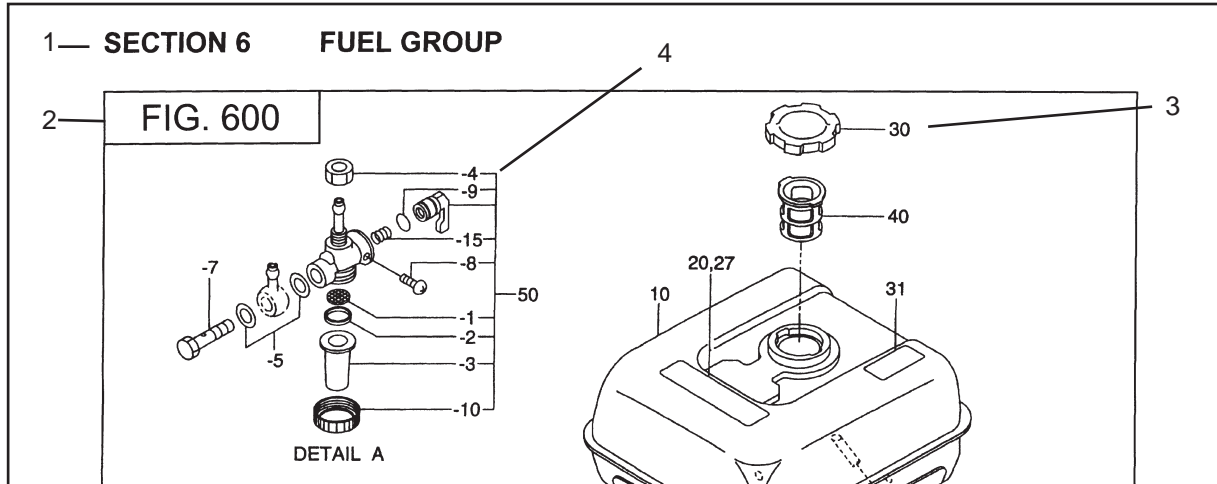

REF.	PART NO.	DESCRIPTION	QTY.	REMARKS	FROM-TO	FIG.
10	267-60103-01	FUEL TANK CP	1	YD, YS TYPE, BLACK		600
	267-60101-01	FUEL TANK CP	1	YELLOW		600
27	073-20039-00	LABEL, WARNING	1	YD, YS TYPE		600
30	043-04300-15	FUEL TANK CAP CP	1			600
31	267-95201-03	LABEL, EMISSION	1	YD, YS TYPE		600
40	064-13600-10	FUEL FILTER	1			600
50	064-20021-01	FUEL STRAINER AY	1			600
-1	064-20002-20	FILTER	1			600
-2	064-20002-30	GASKET	1			600
-3	064-20019-10	CUP	1			600

1. SECTION NAME Parts are broadly classified according to their functions. Refer to the Group Index (table of contents) for respective section name.
2. FIG. No. The FIG. number indexes the reference and part numbers to the illustration. Figure numbers that vary only in the tens place (i.e.: 700 and 710) are in a group of the same section (i.e.:Electrical Device Group).
3. REF. No . The Reference number identifies the part illustration with the corresponding part number in the part list.
4. SUBASSEMBLY SUBASSEMBLY parts of part assembly are listed below the assembly part. The subassembly part reference number is indicated by the number led by "-" such as "-1", "-2".
5. PART NUMBER It is the number assigned for sales unit. Use the PART No. when making an order.
6. DESCRIPTION It is designation of the part.
7. QTY. Quantity of each part used for each product.
8. REMARKS This gives a distinctive feature and/or a supplementary comment for the type, the specification, and the part concerned. It also shows part number(s) interchangeable for the part.
9. FROM-TO This section shows the CODE No. to indicate the history of progress in which improved parts have been introduced in the product. The FROM-TO CODE No. helps to identify PART No. being employed in the product concerned. See the examples below:
  - The part is used in the product irrespective of CODE No.
  - 2101- The part is used in the products with CODE No. of 2101 and after this number.
  - 2100 The part is used in the products with CODE No. of 2100 and before this number.

# GROUP INDEX

Group Name	Page
CRANKCASE GROUP .....	6
CRANKSHAFT GROUP .....	8
INTAKE and EXHAUST GROUP .....	10
GOVERNOR GROUP .....	18
COOLING and STARTING GROUP .....	22
FUEL, LUBRICANT GROUP .....	26
CARBURETOR GROUP .....	28
ELECTRIC DEVICE GROUP .....	32
ACCESSORY GROUP .....	38

INDEX OF DESCRIPTION SYMBOLS			
SYMBOL	DESCRIPTION	SYMBOL	DESCRIPTION
AY .....	ASSEMBLY	P= .....	PITCH (in mm)
CP .....	COMPLETE	P.T.O. (PTO) .....	POWER TAKE OFF
EX .....	EXPORT (from Japan)	REF .....	REFERENCE
FIG .....	FIGURE	R.H. (RH) .....	RIGHT HAND SIDE
FR .....	FRONT	RR .....	REAR
" .....	INCH	STD. ....	STANDARD
INCL. ....	INCLUDE	SW .....	SWITCH
-L .....	LITER	T= .....	THICKNESS (in mm)
L= .....	LENGTH (in. mm)	UN .....	UNIT
L.H. (LH) .....	LEFT-HAND SIDE	U.S. ....	UNDER SIZE
MECH .....	MECHANICAL	~V .....	VOLTAGE
NO (NON) .....	NONE	~W .....	WATT
OPT .....	OPTIONAL	W/ .....	WITH
O.S. ....	OVER SIZE	W/O .....	WITHOUT

SECTION 1 CRANKCASE GROUP

FIG. 100

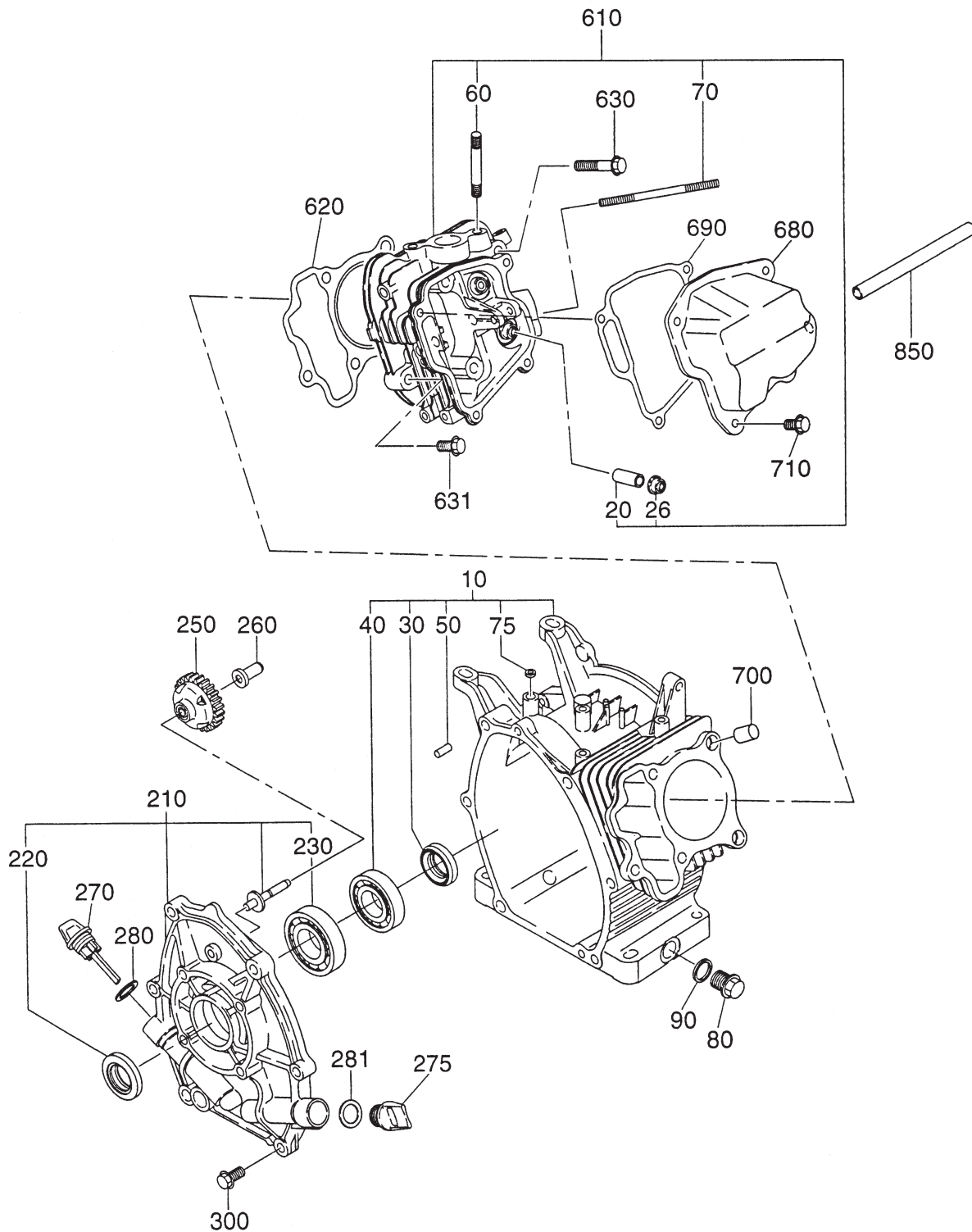



SECTION 2 CRANKSHAFT GROUP

FIG. 200

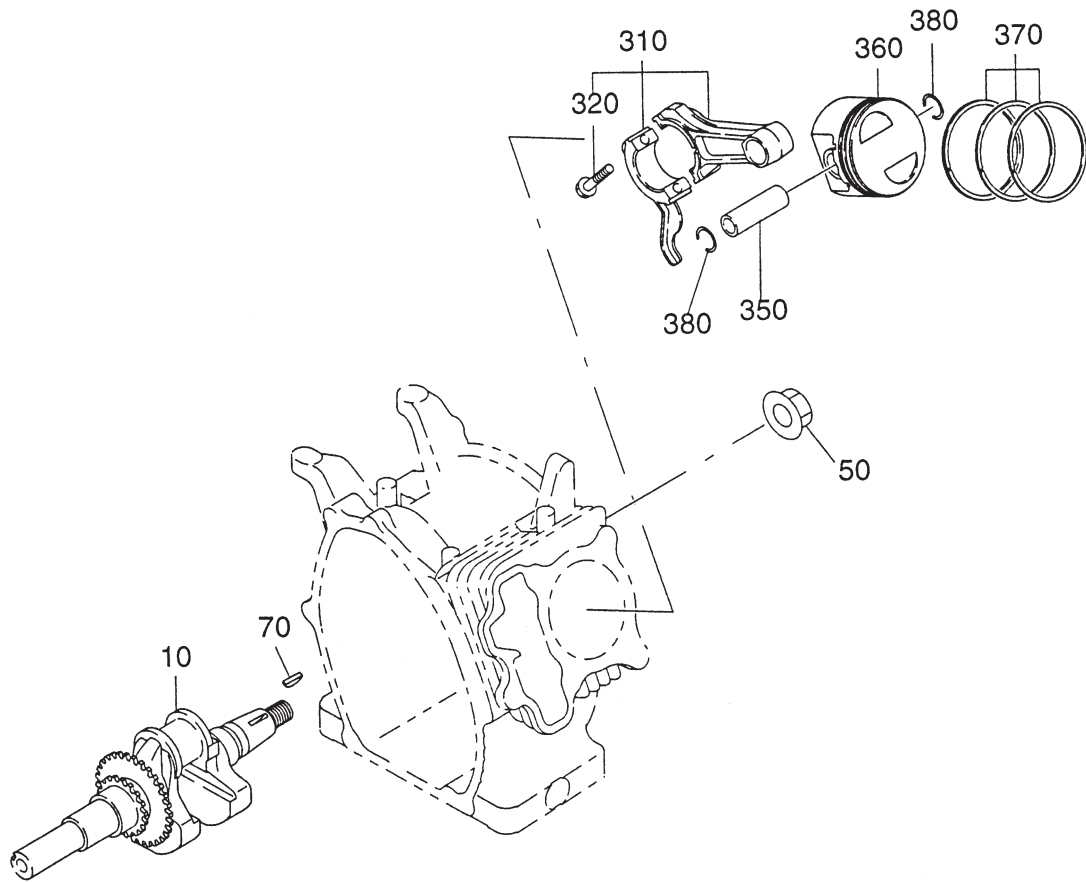





SECTION 3 INTAKE and EXHAUST GROUP - New Style

FIG. 300

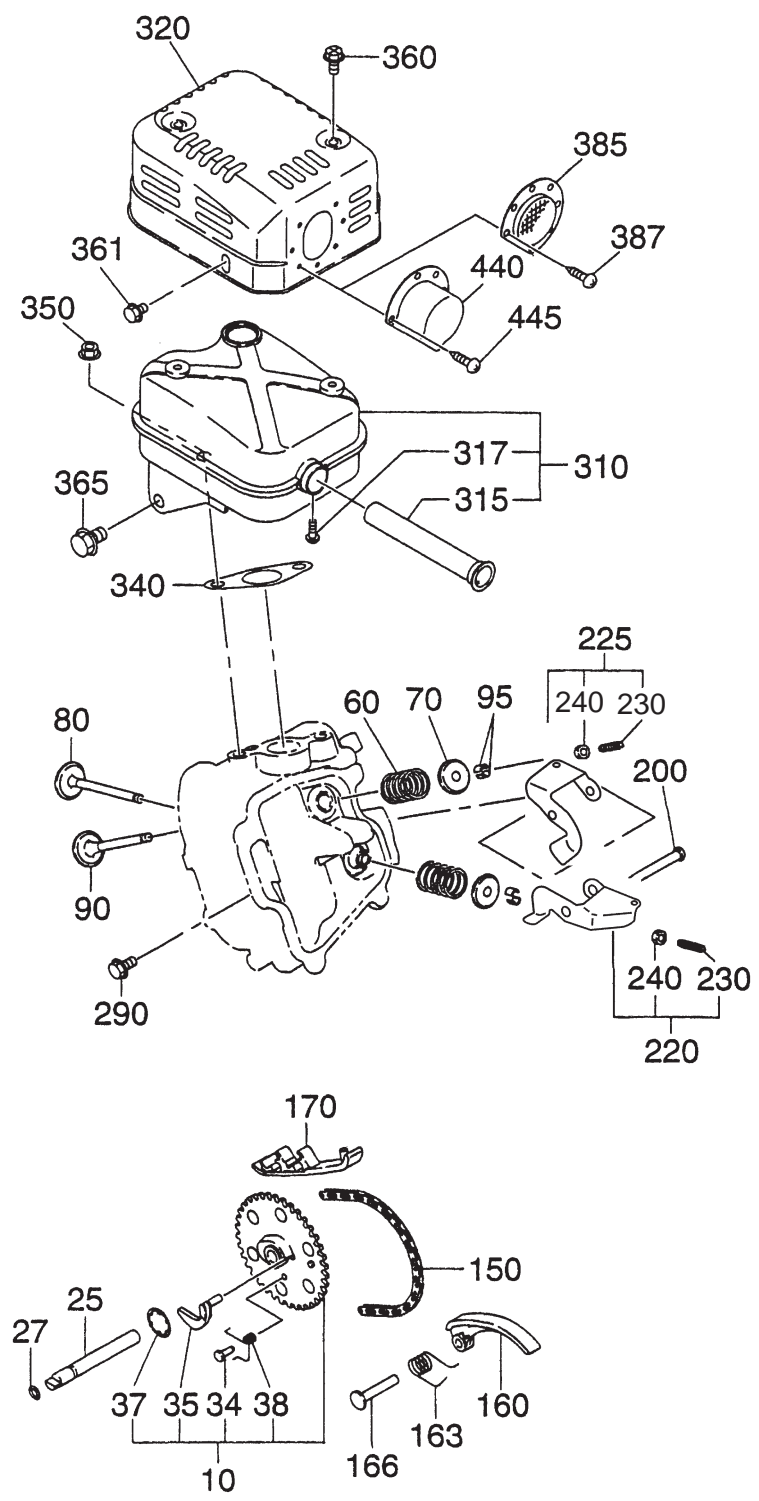

### SECTION 3 INTAKE and EXHAUST GROUP - New Style

REF.	PART NO.	DESCRIPTION	QTY.	REMARKS	FROM-TO	FIG.
10	277-31601-31	CAMSHAFT	1			300
25	277-35101-03	PIN, camshaft	1			300
27	024-00600-10	O RING	1			300
34	277-38601-03	PIN, spring	1			300
35	277-36401-03	RELEASE LEVER	1			300
37	277-36501-03	CLIP	1			300
38	277-38702-03	RETURN SPRING	1			300
60	279-33601-03	VALVE SPRING	2			300
70	269-33701-03	SPRING RETAINER	2			300
80	277-33401-H3	INTAKE VALVE	1			300
90	277-33501-H3	EXHAUST VALVE	1			300
95	132-10KA0-31	COLLET VALVE	4			300
150	277-35601-11	TIMING CHAIN	1			300
160	277-36911-03	TENTIONER	1			300
163	277-37101-03	SPRING, tentioner	1			300
166	277-36902-03	PIN, tentioner	1			300
170	277-36913-13	CHAIN GUIDE	1			300
200	277-35002-01	PIN, rocker	1			300
202	003-13050-00	CLIP	1			300
220	277-36201-00	ROCKER ARM, intake	1			300
225	277-36202-00	ROCKER ARM, exhaust	1			300
230	014-90500-20	ADJUST SCREW	1			300
231	014-90500-20	ADJUST SCREW	1			300
240	017-00500-30	NUT	1			300
241	017-00500-30	NUT	1			300
290	011-00600-20	FLANGE BOLT	1			300
310	277-30111-J1	MUFFLER CP	1		7000~	300
	277-30111-H1	MUFFLER CP	1		~6999	300
315	277-37601-01	SPARK ARRESTER	1			300
317	015-00400-60	TAPPING SCREW	1			300
320	277-34201-21	MUFFLER COVER	1		7031~	300
	277-34201-11	MUFFLER COVER	1		~7030	300
340	277-35201-13	GASKET, muffler	1			300
350	980-20082-80	FLANGE NUT	2			300
360	015-20600-90	TAPPING BOLT	2			300
361	011-00600-10	FLANGE BOLT	1			300
365	011-00803-20	FLANGE BOLT	1			300
387	015-00400-60	TAPPING SCREW	2			300
440	277-37001-H1	DEFLECTOR	1			300
540	277-32902-J1	INSULATOR	1			300
550	277-32903-J3	GASKET 2, insulator	1			300
560	277-35902-J3	GASKET 1, insulator	1			300
570	002-38060-00	FLANGE NUT	2			300
580	011-00600-50	FLANGE BOLT	1			300

SECTION 3 INTAKE and EXHAUST GROUP

FIG. 320

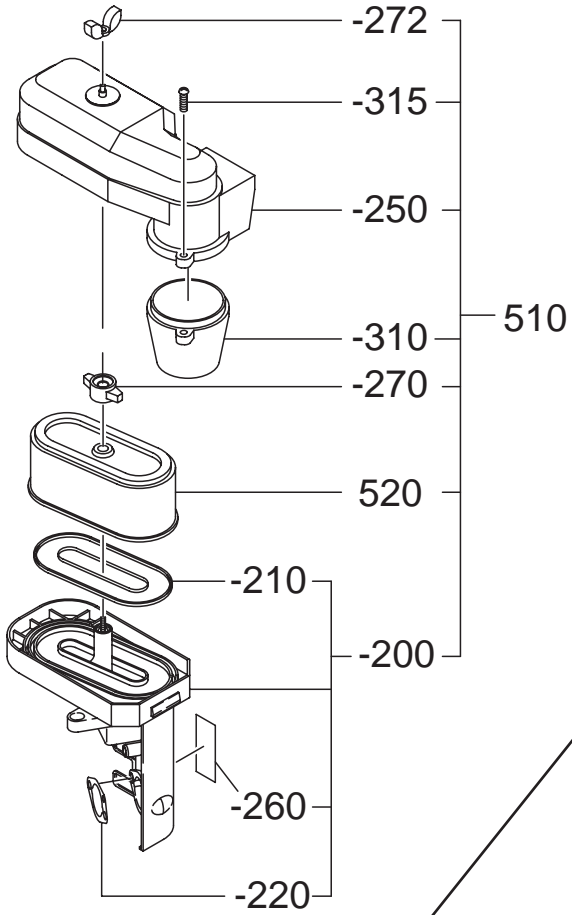



SECTION 4 GOVERNOR GROUP - New Style

FIG. 400

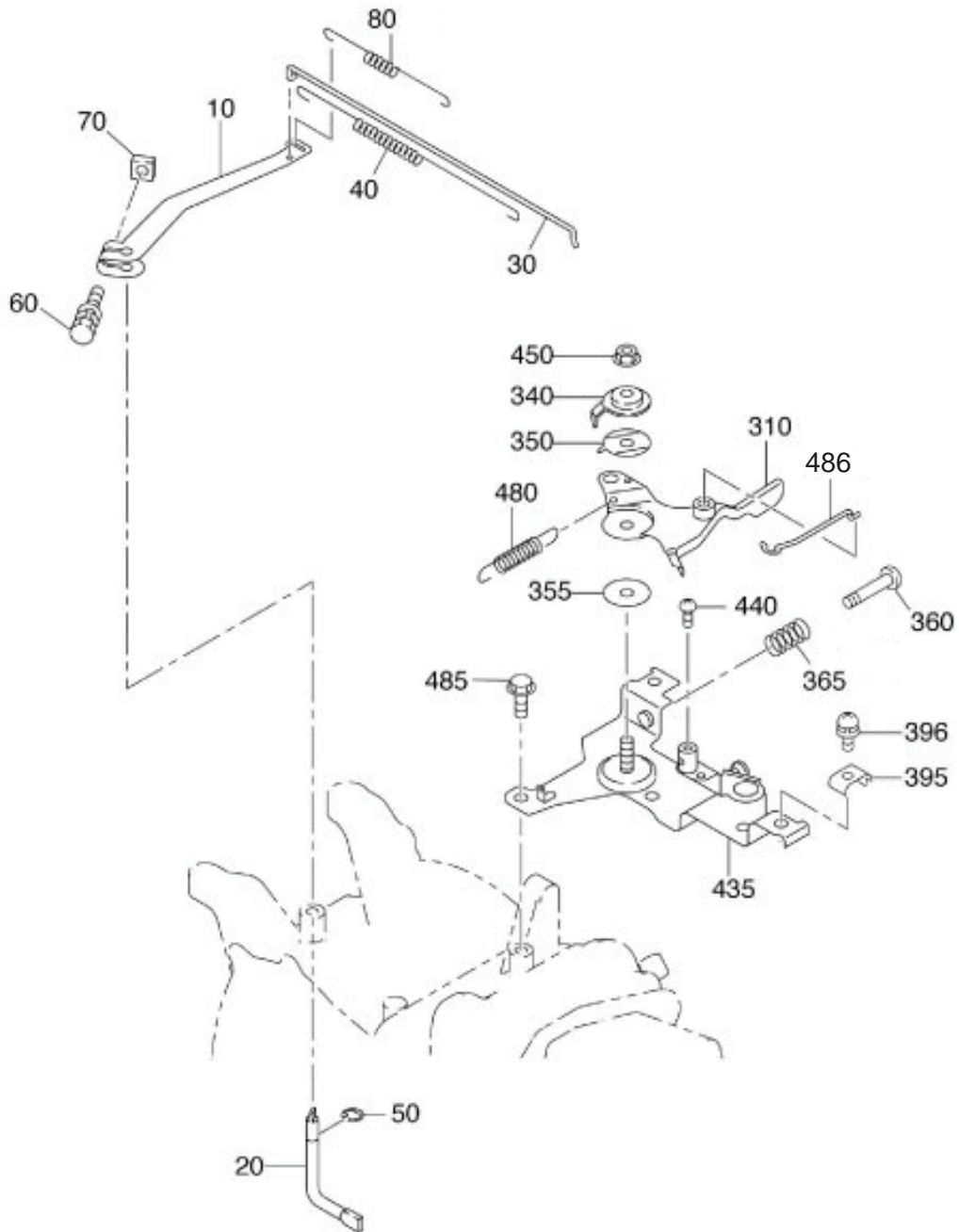



SECTION 5 COOLING and STARTING GROUP

FIG. 500

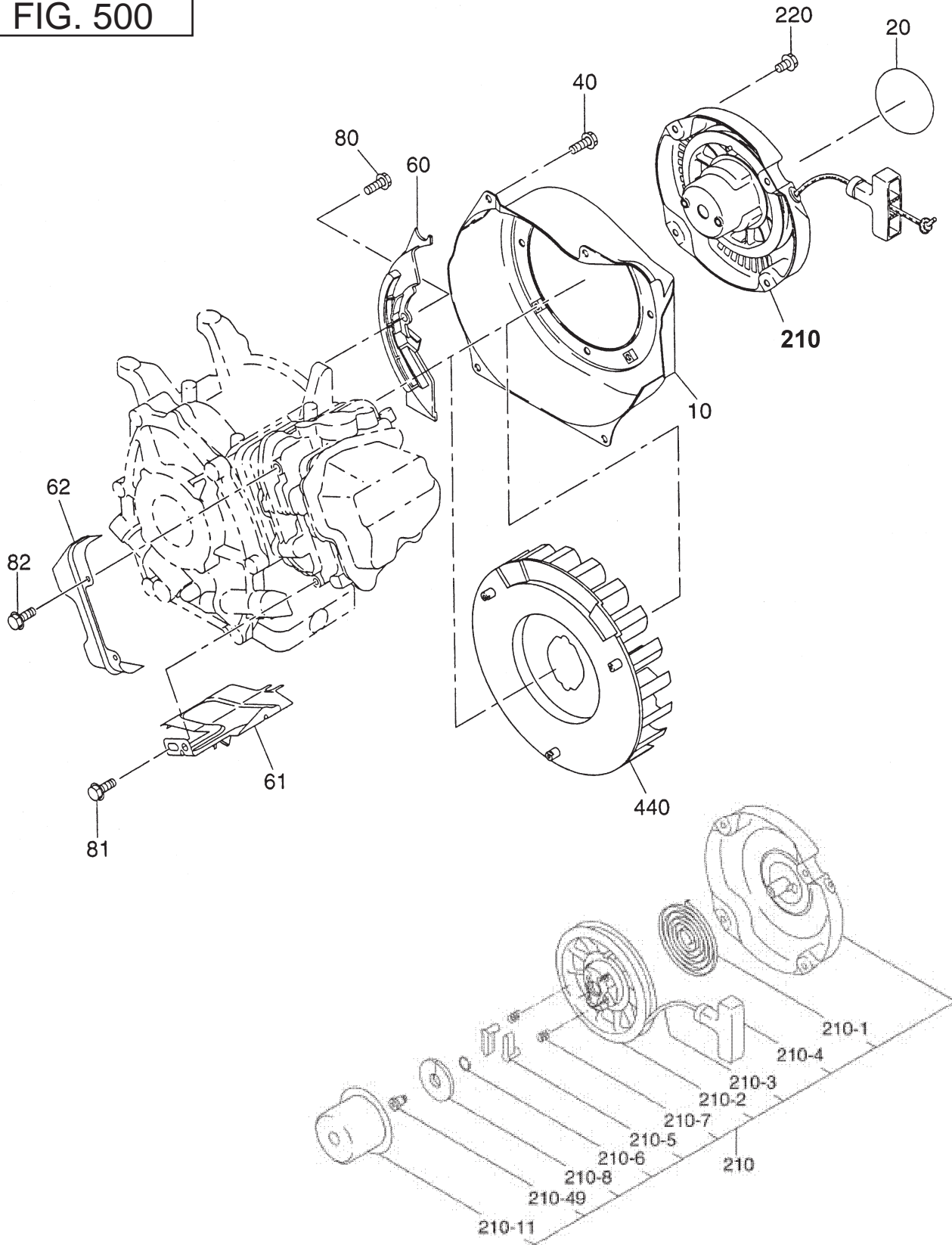





**SECTION 5      COOLING and STARTING GROUP**

**FIG. 510**



SECTION 6 FUEL, LUBRICATION GROUP

FIG. 600

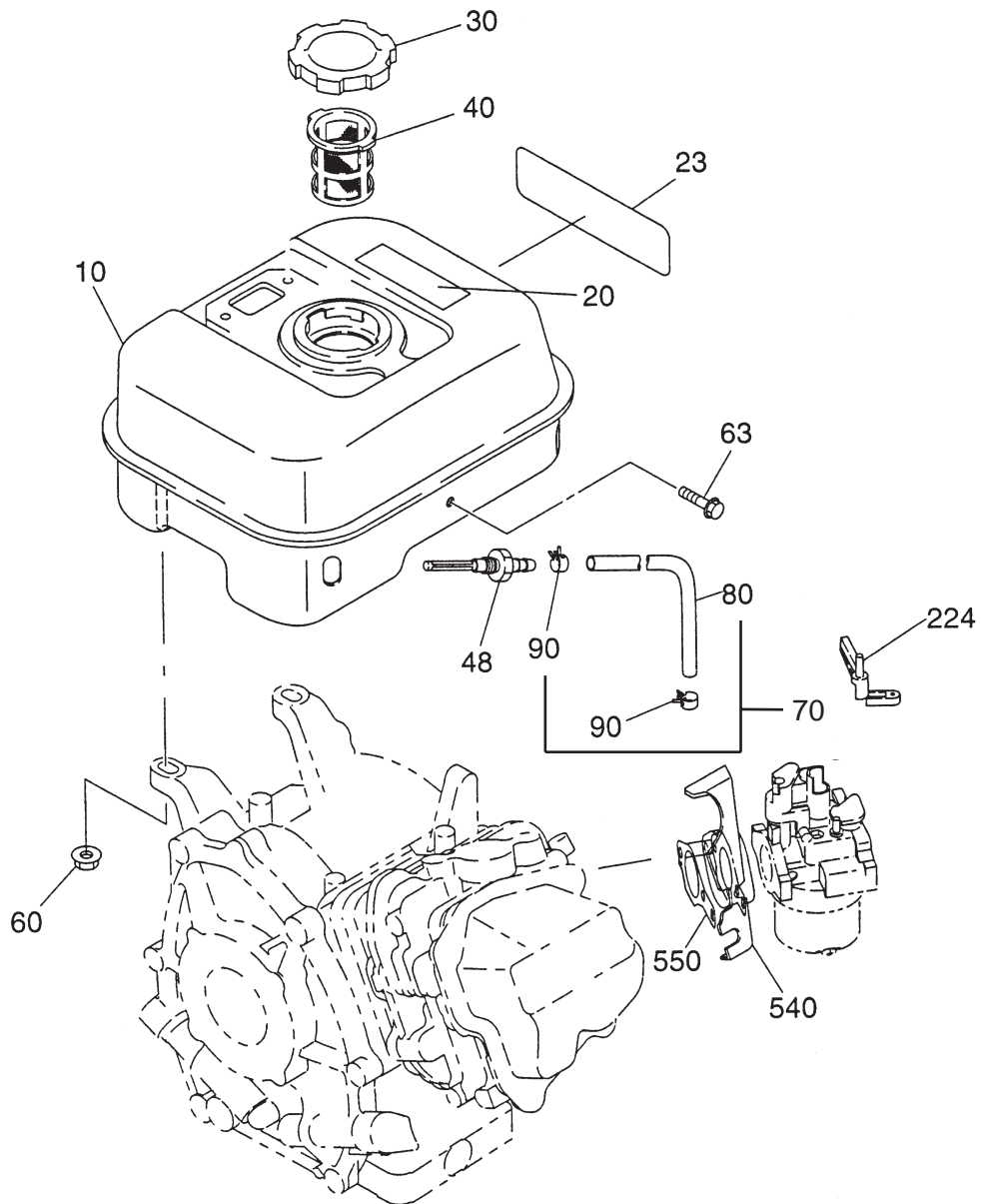



SECTION 6 FUEL, LUBRICATION GROUP

FIG. 610

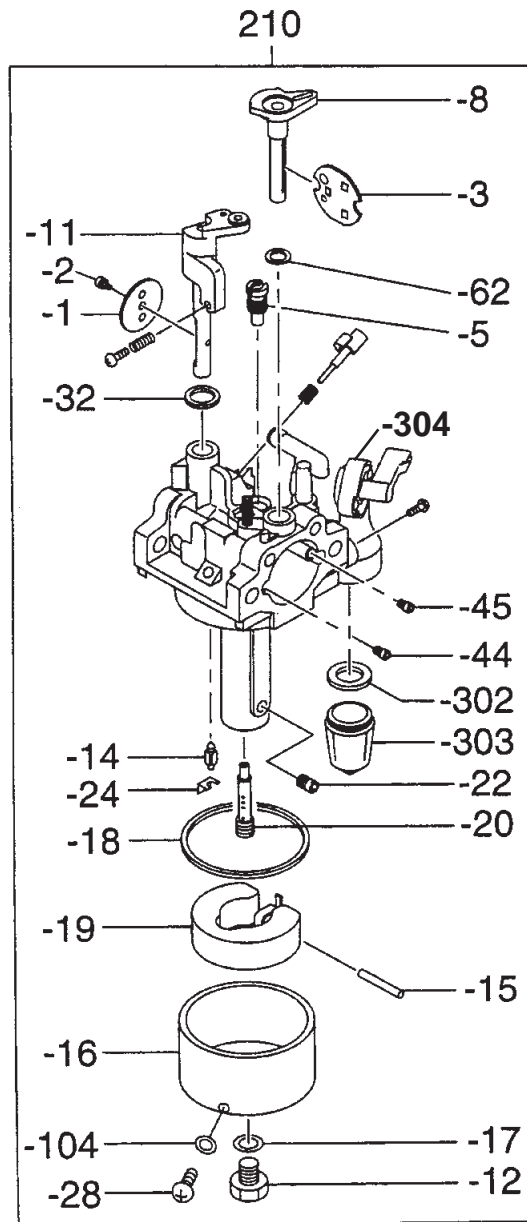



SECTION 7 ELECTRIC DEVICE GROUP

FIG. 700

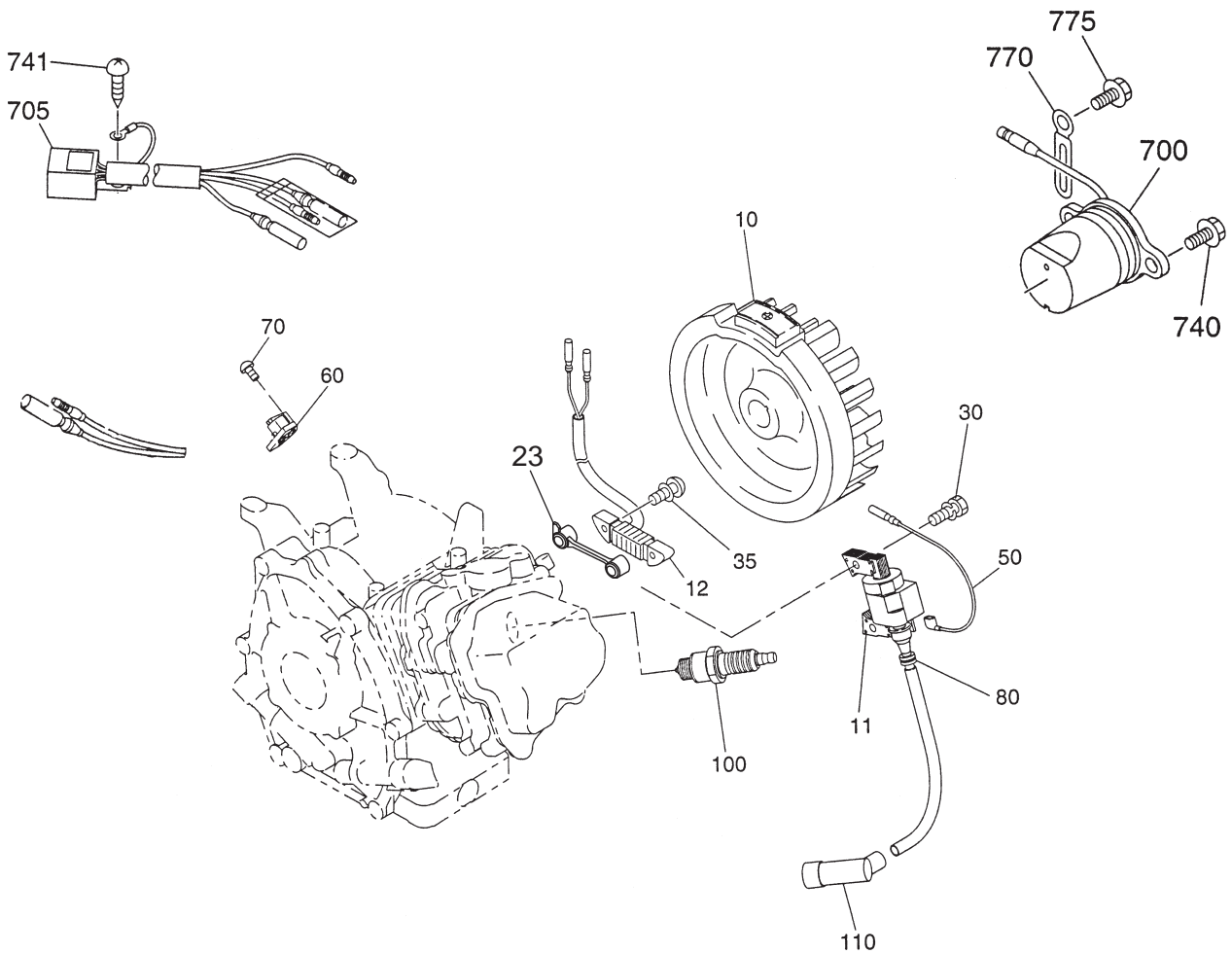





SECTION 9    ACCESSORY GROUP

FIG. 900

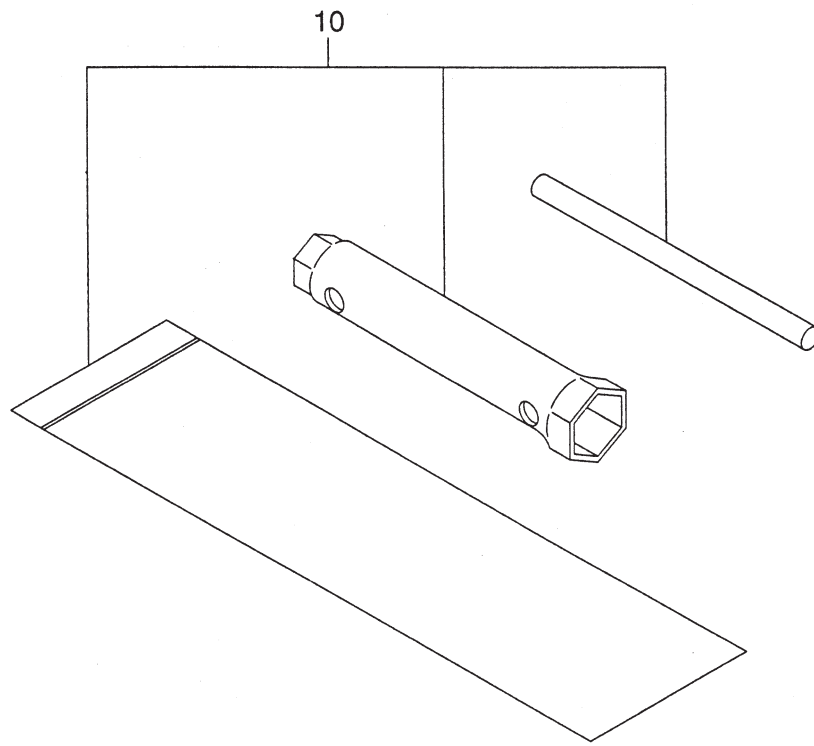



PRINTED IN THE USA