

BRUKSANVISNING	SV ... 4
KÄYTTÖOHJEET	FI ... 10
BRUGSANVISNING	DA..16
BRUKSANVISNING	NO..22
GEBRAUCHSANWEISUNG	DE...28
INSTRUCTIONS FOR USE	EN...35
MODE D'EMPLOI	FR....41
GEBRUIKSAANWIJZING	NL...49
ISTRUZIONI PER L'USO	IT.....56
INSTRUCCIONES DE USO	ES63
INSTRUÇÕES DE UTILIZAÇÃO	PT ... 70
INSTRUKCJA OBSŁUGI	PL....77
ИНСТРУКЦИЯ ПОЛЬЗОВАТЕЛЯ	RU...84
NÁVOD K POUŽITÍ	CZ ..92
HASZNÁLATI UTASÍTÁS	HU..98
NAVODILA ZA UPORABO	SL..105

8214-2210-80

STIGA

Silex 500-G

Silex 500R-G

STIGA[®]

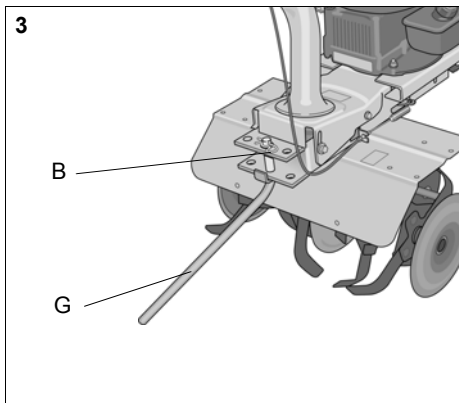
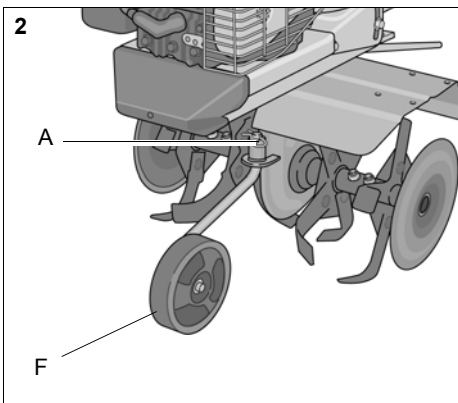
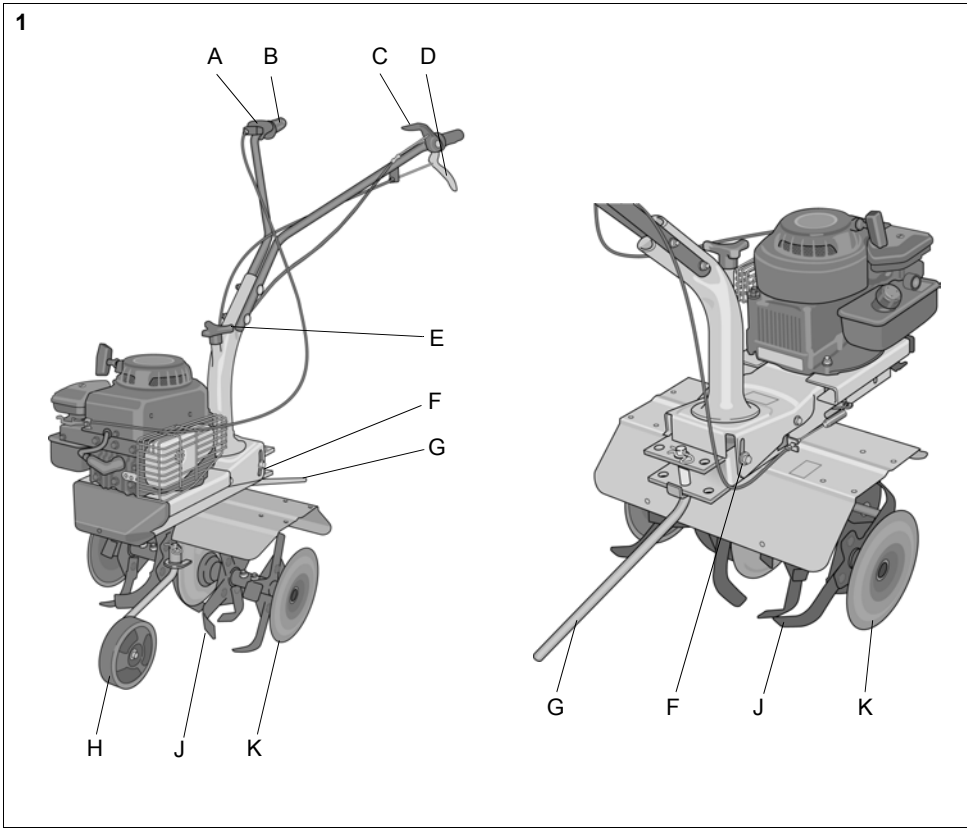

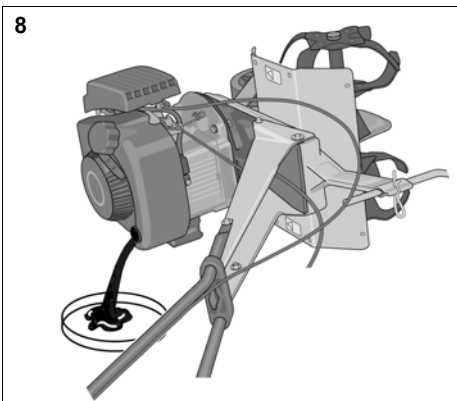
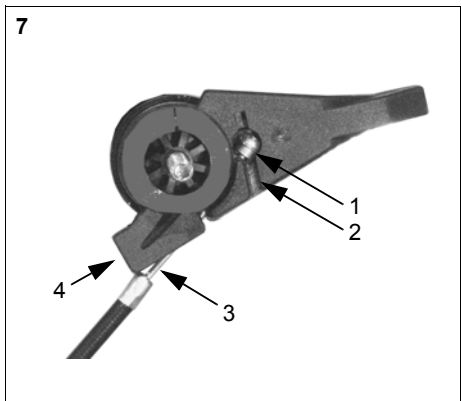
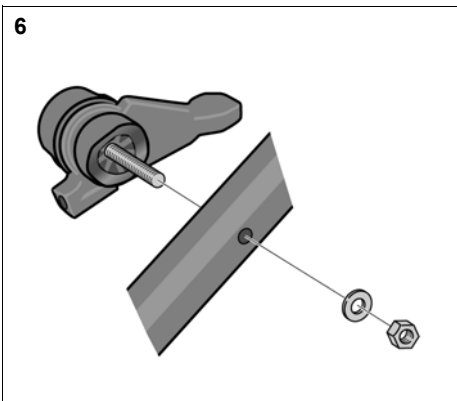
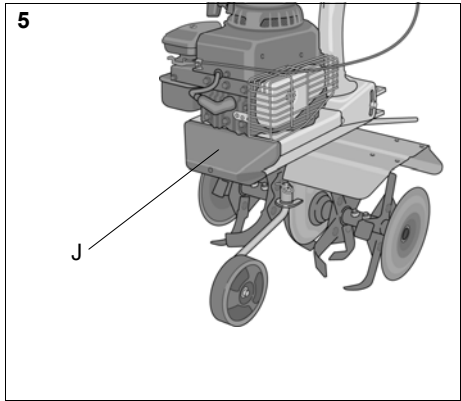
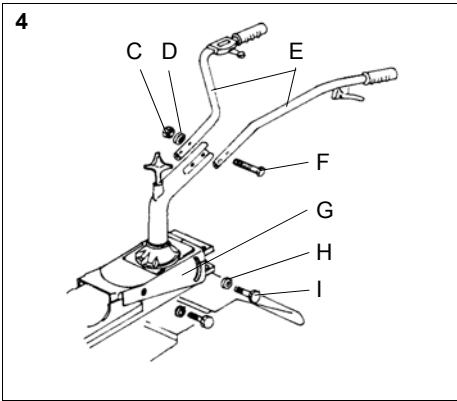

1 SYMBOLS

The following symbols can be found on the rotary cultivator/in these instructions. These will provide a reminder of the care and attention that is required during operation. If any symbol is missing, has been damaged or is illegible, it must immediately be replaced with a new one.

This is what the symbols mean:



Warning! Read the owner's manual before operating the machine.



Warning! Rotating blade.



Warning! This symbol highlights important text in these instructions. Risk of serious personal injury or damage to the machine if the instructions are not followed.

2 SAFETY INSTRUCTIONS

2.1 GENERAL

- Read through this instruction book carefully and make sure you understand the contents before using the tiller.
- The tiller must only be used for gardening purposes.
- Keep children away from the tiller.
- Do not allow children or persons who have not read the instructions to handle the tiller.
- The tiller is manufactured in accordance with current standards, and must not be modified or rebuilt.
- All the symbols on the tiller should be kept intact.
- The user is liable for damages incurred by a third party.

WARNING for petrol. Petrol is highly inflammable: Petrol must be stored in the requisite containers.

- Always fill-up outdoors and with the engine switched off.
- Do not smoke when filling-up.
- There must be no naked flames or other sources of heat in the vicinity of the petrol.
- Do not start the engine if petrol has spilled out. Move the machine and allow the petrol to evaporate before starting the machine.
- Screw on the filler cap correctly after filling up.

- Set the throttle control in the "Stop" position, and close the petrol cock when the machine has been stopped.
- Switch off the engine before transporting the machine. Never lift the machine by yourself. The machine is lifted by two persons, one on each side holding the steering and the rotor axle. Wear protective gloves and hold the machine upright when lifting.
- When the machine is loaded on a trailer or tail-board it should be run up on a ramp by using its wheel.

2.2 PREPARATIONS

- Before starting work, remove all foreign objects such as stones, glass, cables, metal objects and other loose objects.
- Toys, hoses and other objects can be damaged.
- Check that the tiller is in good condition before using it.
- Check that all nuts and bolts are tightened.

2.3 OPERATING

- Always operate the machine at low speed when working on stony ground.
- Do not change the engine's speed setting. The engine must not be overspeeded.
- The work area should be well illuminated during the work.
- The tiller must not be used when other persons, especially children, are in the vicinity.
- The tiller must not be used without the splash-guards or protective cover.
- The tiller must not be used if the operator is ill, has taken medicine, or is under the influence of other substances which reduce one's reactions.
- The tiller must not be used on terrain which slopes more than 20°.
- The user is responsible to ensure that all risks in the terrain are taken into consideration, and that procedures are taken to prevent accidents. This particularly applies to sloping, slippery or loose terrain.
- Start the engine carefully, according to the instructions in this manual. No parts of the body must come in contact with the rotors.
- The engine must never be started in an enclosed area.
- The carbon monoxide in the engine's exhaust fumes is poisonous and can cause death.

- Wear tightly fitting clothes and heavy-duty shoes which completely cover the feet.
- The tank should only be half full when operating on slopes. Petrol can leak out.
- The engine must be stopped in the following circumstances:
 - When the machine is left unattended
 - Before the machine is filled up with petrol
- Always make sure you have a good footing, especially on slopes.
- Check that no one is in front of you or beside you when starting the blades. Keep a steady grip on the steering. The machine will lift when the rotors are started. Use extra caution when backing.
- Always keep at a safe distance to the rotors when working.
- Holding the steering correctly ensures a safe distance.
- No person must come closer than 20 m to the machine when working on slopes. The user must hold the steering firmly with both hands all the time.
- Working on stony or hard ground demands extra attention from the operator. The machine becomes more unstable.
- Never touch the engine when operating the machine, or just afterwards. Risk for burn injuries.

2.4 AFTER OPERATING

- Allow the engine to cool before putting the machine in a storeroom. Fire risk!
- Remove dirt and foreign material before putting the machine in a storeroom. The area round the petrol tank and muffler must be kept clean from leaves, oil, petrol or other foreign materials. Fire risk!
- If the petrol tank is to be emptied, do this outdoors and when the engine is cold. Fire risk!
- The machine should be stored in a dry place. The machine must not be stored with fuel in the tank in rooms where there are naked flames, sparks or other strong sources of heat.

2.5 MAINTENANCE

- Carry out maintenance regularly. All nuts and bolts should always be tight.
- Only use genuine spare parts which are in good condition. Spare parts must not be repaired. They must be replaced if they are defective. Poor quality spare parts can lead to personal in-

jury. If the muffler is damaged it must be replaced.

- The engine must be stopped and the spark plug lead disconnected in the following circumstances:

When adjusting the rotors.

When the machine is to be cleaned or repaired. When checking after a collision with a solid hard object. Carry out the necessary repairs before continuing to work.

If the machine begins to vibrate abnormally. Carry out the necessary repairs before continuing to work.

- Wear protective gloves when working with the rotors.

3 ASSEMBLY

3.1 Auxiliary wheel

Install the auxiliary wheel (2:F) in the front hole and lock using the locking pin (2:A).

3.2 Depth skid

Install the depth skid (3:G) in the middle hole at the rear and lock using the locking pin (3:B).

3.3 Handle

Install the handle's base (4:G) with handle (4:E) as follows:

1. Position the base (4:G) on the machine.
2. Remove the four screws (4) with the washers (4:H). Do not tighten the screws yet.
3. Hold the right and left handle (4:E) in place and install using the two screws (4:F) with nuts and washers (4:C+D). Tighten the screws.
4. Set the handle to a comfortable working height and tighten the screws (4:H).

3.4 Throttle control

Install the throttle (1:A) on the left handle. See fig. 6.

3.5 Throttle cable

1. Install the throttle cable on the engine if not already installed. See the engine supplier's manual.
2. Install the cable in the throttle. See fig. 7.

3.6 Cable for reverse control

Only applies to 500R-G.

The cable is marked **R**.

1. Hook the cable in the reverse control (1:C) and insert the cable in the gap in the cable housing's mounting on the left handle.
2. Adjust the cable sleeve if necessary.

3.7 Drive cable

1. Hook the cable in the drive control (1:D) and insert the cable in the gap in the cable housing's mounting on the left handle.
2. Adjust the cable sleeve if necessary.

3.8 Front protection

Install the front protection (5:J). Use the screws supplied.

4 DESCRIPTION

The rotary cultivator is driven by a four-stroke engine and is intended for soil cultivation in private gardens. The most important parts and controls of the rotary cultivator are described below.

4.1 Reverse control (1:C)

Only applies to 500R-G.

The control is used to start the rotor for reverse when the engine is running.

The reverse control and drive control (1:D) must never be activated at the same time.



Control in idle mode (forward) – No drive.



Control moved backwards – The machine reverses.

4.2 Drive control (1:D)

The control is used to start the rotor for forward motion when the engine is running.

The reverse control (1:C) and drive control must never be activated at the same time.



Control in idle mode (down) – No drive.



Control pulled in – Forward operation.

4.3 Throttle and stop (1:A)

The control determines the engine's rpm and has start and stop positions.

4.4 Handle (1:B)

The handle has two handgrips that are used to operate the machine over the area to be cultivated.

4.5 Fuel cap

See the accompanying engine manual.

Unscrew the fuel cap to fill with petrol. The fuel cap must always be closed during operation.

4.6 Angle adjustment handle (1:E)

Release the knob and set the handle to the desired angle.

Then retighten the knob again.

4.7 Height adjustment handle (1:F)

Slacken off the screws and set the handle to the desired height.

Then retighten the screws again.

4.8 Oil filling/draining



Always check the oil level before starting the engine.

See the accompanying engine manual.

Plug for oil filler and checking the oil level.

To drain the oil, the machine must be tilted so that the oil runs out from the same hole.

4.9 Auxiliary wheel (1:H)

The auxiliary wheel is intended to assist transport of the machine and has two positions.

- The auxiliary wheel must not be installed when carrying out work.
- The auxiliary wheel must be installed when transporting.

Remove/install the auxiliary wheel as follows:

1. Pull out the locking pin (2:A).
2. Remove the auxiliary wheel downwards.
3. Reinstall the locking pin in the auxiliary wheel arm.

Install in reverse order

4.10 Rotors (1:J)



Nobody must be close to the dangerous rotors during operation.

The rotors are made of special steel and work the soil at the same time as the machine is propelled forwards.

4.11 Cutting disc (1:K)

 **Nobody must be close to the dangerous cutting discs during operation.**

The cutting discs are on respective rotor axles and are designed to border the working area and facilitate control of the machine.

4.12 Choke

 **The choke must never be activated during operation. This will damage the engine.**

See the accompanying engine manual.
The choke must be activated at cold starts.

4.13 Starting handle

See the accompanying engine manual.
Handle for starting the engine.

4.14 Depth skid (1:G)

The task of the depth skid is to keep the machine stable so that the soil can be cultivated.

The depth skid has three positions. Shifting takes place as follows:

1. Pull out the locking pin (3:B).
2. Pull out the depth skid and reinstall in the desired position.
3. Reinstall the locking pin.

The different operating properties are shown according to the table below:

Holes	Properties
Left	The machine works itself forward, angled to the left.
Middle	The machine works itself forward without being angled to either side.
Right	The machine works itself forward, angled to the right.

5 OPERATION

5.1 Fuel



Read and understand all safety instructions.

No fires or smoking near to petrol.

Use 92-95 octane lead free petrol.

Oil-mixed petrol designed for 2-stroke engines must never be used.

Filling



Read and understand all safety instructions.

If the engine has been running, wait a few minutes until it has cooled before filling up.

Fill carefully to prevent the spillage of fuel.

Move the rotary cultivator at least 3 metres from the filling site before starting.

Fill as follows:

1. Clean around the fuel cap.
2. Unscrew the filler cap.
3. Fill using a funnel or use a filler can with spout to prevent spillage.
4. Tighten the filler cap.
5. Move the rotary cultivator at least 3 metres from the place of filling before starting.



Move the rotary cultivator at least 3 metres from the filling site before starting.

5.2 Engine Oil



Always check the oil level before starting. Otherwise there is a risk of serious engine damage.

Also see "4.8". Check the oil level as follows:

1. Position the machine so that the engine is horizontal.
2. Unscrew the oil filler and check that the oil level is at the upper mark on the dipstick. See the accompanying engine manual.
3. Top up the oil if necessary. Use normal engine oil SAE 10W-30.
4. Reassemble the oil filler cap.



Move the rotary cultivator at least 3 metres from the filling site before starting.

5.2.1 Starting the engine from cold

1. Put the choke in position "CHOKE". See the accompanying engine manual.
2. Set the throttle (1:A) in the "START" position.
3. Hold the handle with one hand and slowly pull the starter handle with the other hand. See the accompanying engine manual. When the starter mechanism engages, quickly and forcefully pull the starter handle until the engine starts.

NOTE! Do not pull the cord hard to its stop position and do not release it in the pulled out position. This damages the starter mechanism.

5. Reset the choke after 3-5 seconds.

5.2.2 Starting a warm engine

Start a hot engine according to points 2 and 3 above. The choke/primer must not be used.

5.3 Operating

1. Tip the rotary cultivator back slightly so that the rotor is above ground.
2. Activate the drive control (1:D).
3. Tilt the cultivator forward so that it works its way into the soil.
4. If the machine has a reverse control, activate it (1:C).

5.4 Stop

Stop the rotary cultivator by setting the throttle and stop control (1:A) to "STOP".

5.5 Operating tips

The rotors propel the machine forward. The speed of the rotors is controlled by the throttle (1:A).



Keep hands and feet away from rotating parts (1:J, K).

The optimum working depth varies with soil conditions. The working depth is determined by how hard the depth skid is pushed down during propulsion. Operate and test.

Drive 2-3 times in different directions for best results.

Never operate the machine in wet soil. Clumps of earth are created that are then difficult to break-up. Hard and dry soil requires an extra run, at right angles to the first.



WARNING! Never overload a new machine. Drive carefully for the first 5 hours.

6 STORAGE

Store the rotary cultivator in a dry place. Also see section "Safety instructions".

After draining the petrol, start the engine and allow it to run until it runs out of petrol.

7 MAINTENANCE



WARNING! Repairs must be carried out by the dealer. Otherwise the guarantee becomes invalid.

WARNING! Before carrying out repairs and maintenance, the spark plug connection must be disconnected.

7.1 Periodic maintenance

Before each operation

- Check for fuel leaks.
- Check that all screws are tightened.

After each operation

- Clean the rotary cultivator.
- Check for fuel leaks.

Every 25 operating hours and every 3 months

- Check, clean or replace the air filter.
- Check that all screws and nuts are tightened.

7.2 Air filter

See the accompanying engine manual.



Do not use flammable liquids when cleaning.



Serious engine damage can be caused if the machine is operated with a defective or blocked filter.



The paper filter must never be cleaned with liquid.

The machine is equipped with a pre-filter (foam rubber) and a main filter (paper).

Clean/replace the air filter every 3 months or every 25 operating hours. During operation in dry and dusty conditions, the air filter must be cleaned/replaced every day.

Clean/replace the air filter as follows:

1. Undo the screws or locking tabs and the filter housing.
2. Grasp the main filter (paper) and shake it a few times against a hard surface or blow clean with compressed air from the inside out.

3. Wash the pre-filter (foam rubber) in liquid detergent and water. Then carefully twist the filter out and allow to dry.
4. When the pre-filter is dry, reinstall the filter in reverse order.

The filters must be replaced if very dirty or defective.

7.3 Spark plug

See the accompanying engine manual.

The sparkplug must be replaced in the following cases.

- When the electrodes are burnt.
- If the porcelain insulator indicates damage.
- If the rotary cultivator is difficult to start.

The electrode gap should be 0.7-0.8 mm.

Use sparkplug Champion QC12YC or similar.

7.4 Changing the oil

Change the oil the first time after 2 hours of operation, and subsequently every 25 hours of operation or at least once a season. Change oil when the engine is warm.



The engine oil may be very hot if it is drained off directly after the engine is shut off. So allow the engine to cool a few minutes before draining the oil.

1. Unscrew the cap for oil filling/oil draining. See "4.8".
2. Place a container on the floor.
3. Tilt the machine so that the hole is above the container. See fig. 8.
3. Let the oil run out into the container.
5. Fill with new oil: See "5.2".

7.5 Cleaning



Never use high-pressure washing equipment when cleaning. This can cause water to penetrate between the seals and cause machine damage.

First brush off all dirt. Then wipe down the rotary cultivator using a damp cloth. The underside can be washed with water.

7.6 Fault-tracing

Fault: Difficult to start

Cause: The fuel is too old.

Action: Drain the tank and fill with fresh petrol.

Cause: Sparkplug fault.

Action: Replace spark plug.

Fault: Engine runs unevenly

Cause: Contaminated fuel.

Action: Clean the petrol tank and carburettor.

Cause: Sparkplug fault.

Action: Replace spark plug.

Fault: Weak engine, does not run at full throttle

Cause: Blocked air filter

Corrective action: Clean or replace the air filter.

Fault: Stops during operation

Cause: No fuel.

Action: Fill with petrol

8 SERVICE

Authorised service stations carry out repairs and servicing. They always use genuine spare parts.



Under no circumstances may parts other than genuine spare parts be used. This is a requirement stipulated by the Testing Authority. The machine is approved and tested with these parts.

If the machine requires servicing, repair or maintenance that entails dismantling of the cover, this must be performed by an authorised service station.

The manufacturer reserves the right to make alterations to the product without prior notification.

9 PURCHASE TERMS

A full warranty is issued against manufacturing and material defects. The user must carefully follow the instructions given in the enclosed documentation.

Warranty period

According to relevant laws.

Exceptions

The warranty does not cover damage due to:

- Neglect by users to acquaint themselves with accompanying documentation
- Carelessness
- Incorrect and non-permitted use or assembly
- The use of non-genuine spare parts
- The use of accessories not supplied or approved

Neither does the warranty cover:

- Wear parts
- Normal wear

The purchaser is covered the national laws of each country. The rights to which the purchaser is entitled with the support of these laws are not restricted by this warranty.

GGP reserves the right to make alterations to the product without prior notification.