

AIR HOGS®

SKY SHARK XRB™

INSTRUCTIONS

Ages 8 and up

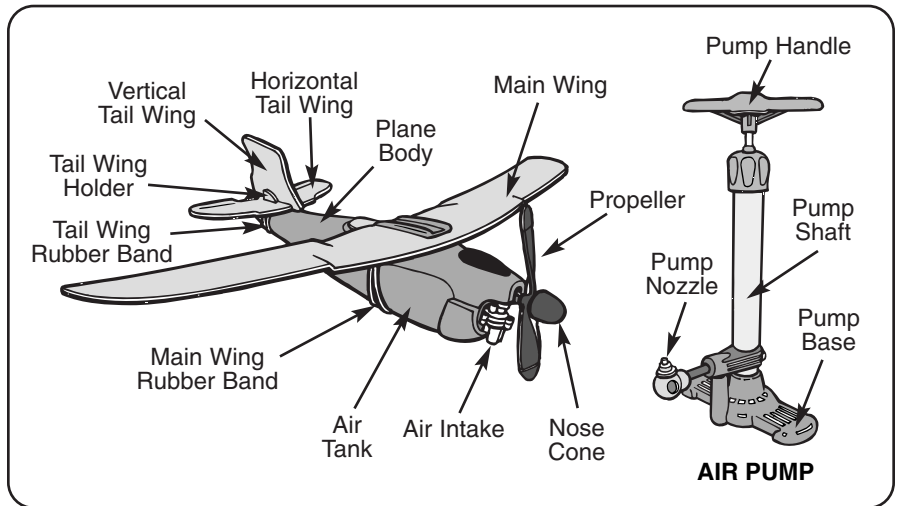

PLEASE READ THESE INSTRUCTIONS CAREFULLY BEFORE FLYING YOUR AIR HOGS® SKY SHARK™

Congratulations! You are the proud owner of original AIR HOGS® the loudest, fastest and furthest flying air pressure plane ever! The secret behind AIR HOGS® is the revolutionary design of the R.A.I.D. air pressure engine, which is built to provide awesome performance and unbeatable flight times.

ASSEMBLY INSTRUCTIONS

STEP 1

Slide the back part of the MAIN WING HARNESS around the BACK MOUNTING PIN on the PLANE BODY.

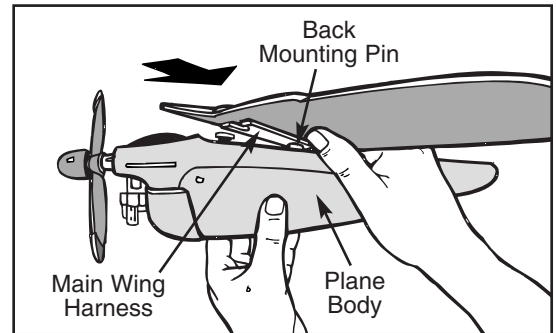
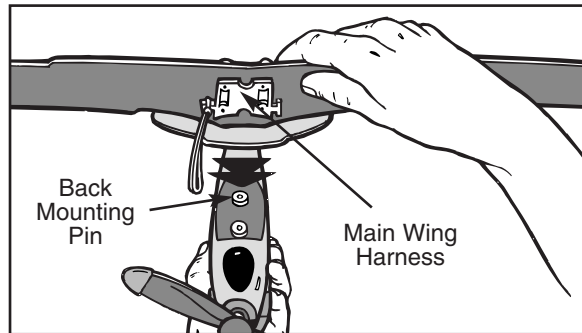

STEP 2

Push down on the front part of the MAIN WING until it 'CLICKS'.
NOTE: The MAIN WING HARNESS should now be secure on the FRONT and BACK MOUNTING PINS.

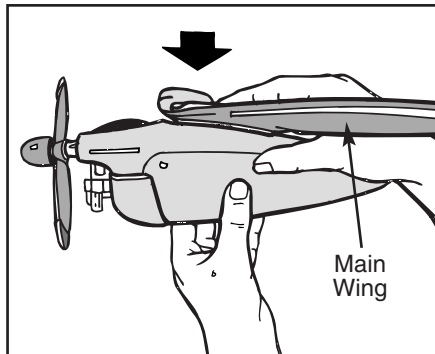

STEP 3

Wrap the MAIN WING RUBBER BAND around the AIR TANK and hook it onto the MAIN WING HARNESS TAB.

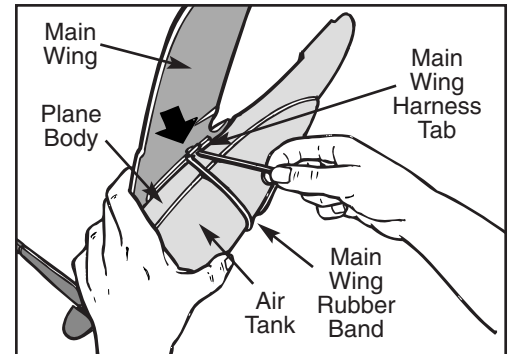

STEP 4

Insert TAIL WING MOUNTING TAB into the TAIL WING SLOT on the rear of the plane.

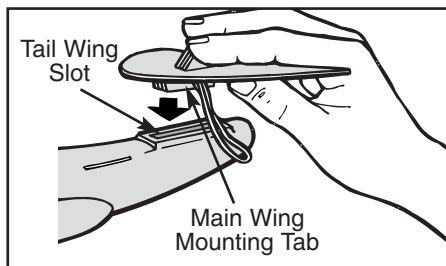

STEP 5

Wrap the TAIL WING RUBBER BAND around the tail of the plane, and hook it onto the TAIL WING HARNESS TAB.

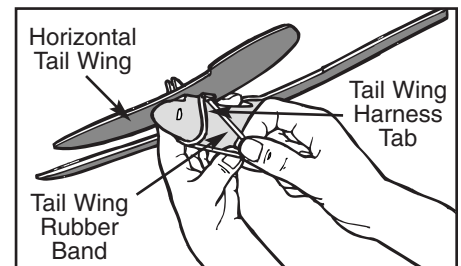

STEP 6

Install the VERTICAL TAIL WING by sliding it into the TAIL WING HOLDER.

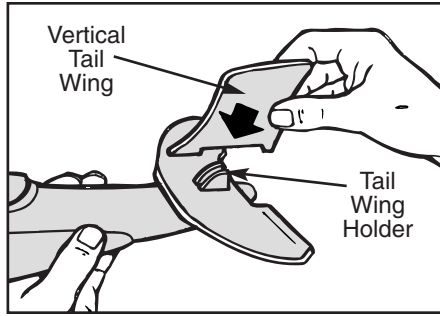

STEP 7

Apply your AIR HOGS® stickers to the surface of the MAIN WING and VERTICAL TAIL WING. See packaging for placement of stickers. Make sure your stickers are on flat, because creases in the stickers will affect the flight.

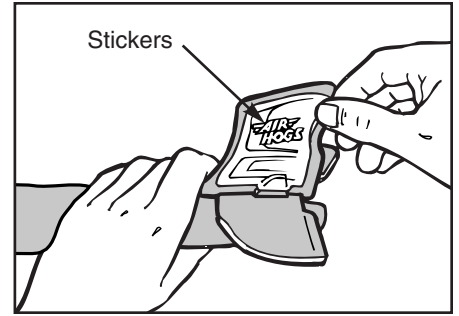

PUMP UP YOUR SKY SHARK™

STEP 1

Push the plane's AIR INTAKE down onto the PUMP NOZZLE.

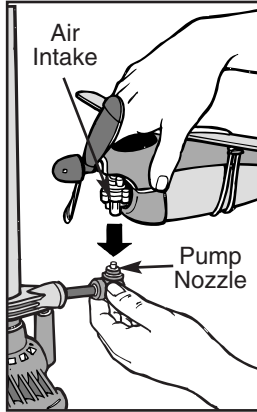

STEP 2

Pump 50 times (or until the air tank is full). The pressure release valve will release air or whistle when AIR TANK is full.

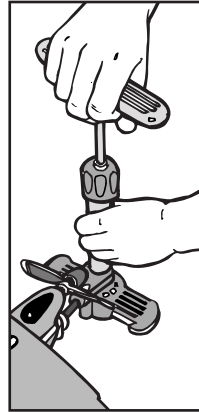

STEP 3

Carefully remove the plane AIR INTAKE from the PUMP NOZZLE.

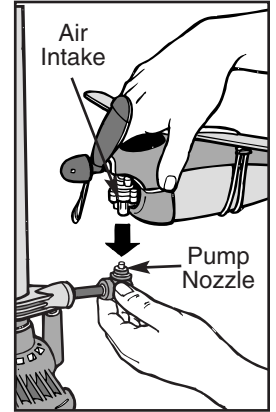

CAUTION: Only use pump supplied with AIR HOGS® Sky Shark™. Do not use any other source to pump AIR HOGS® Sky Shark™.

FLIGHT INSTRUCTIONS

STEP 1

Hold the plane in your launching hand and strike the propeller with your other hand.

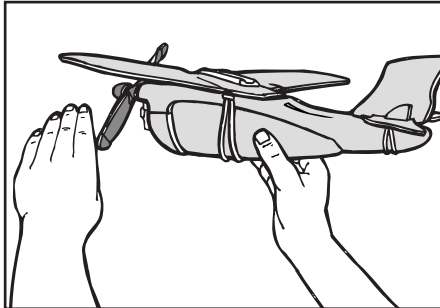

STEP 2

Launch your Sky Shark™ against the wind for best take-off and flight results.

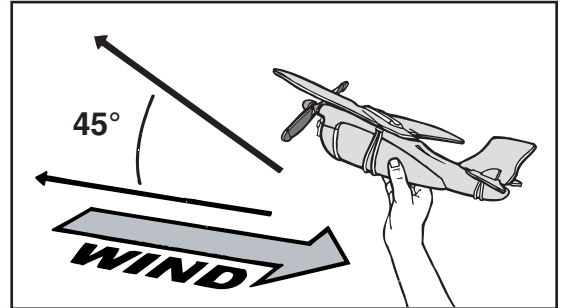

BASIC FLYING TIPS

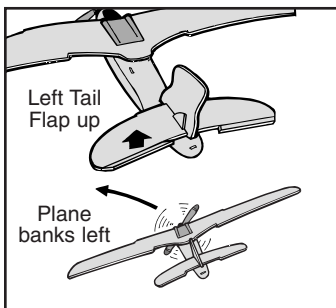

Gently bend the LEFT TAIL FLAP up to make the plane bank to the **left**. NOTE: No change to the RIGHT TAIL FLAP.

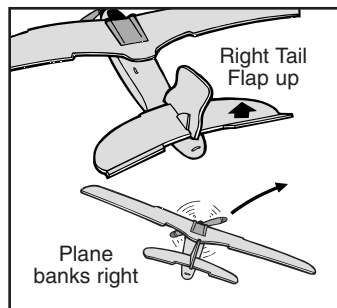

Gently bend the RIGHT TAIL FLAP up to make the plane bank to the **right**. NOTE: No change to the LEFT TAIL FLAP.

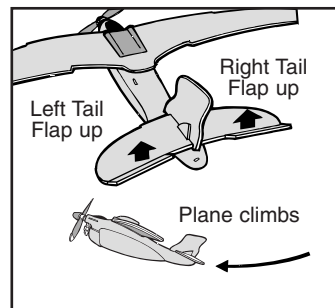

Gently bend both HORIZONTAL TAIL FLAPS up to make the plane **climb higher/faster**.

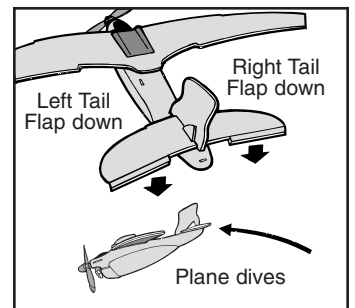

Gently bend both HORIZONTAL TAIL FLAPS down to **prevent plane from crashing/stalling**.

REPAIR CENTER

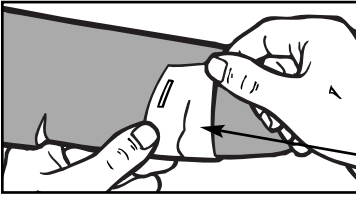

If the wings on your **AIR HOGS™** plane get damaged, they can be easily repaired with clear tape.

CLEAR TAPE

IMPORTANT SAFETY INFORMATION

Keep propeller clear from face, eyes, and fingers. **DO NOT** launch at people or animals. Use caution; make sure people around you know you are playing with Air Hogs®. Recommended for use in wide-open, grassy area. **DO NOT** fly near overhead wires, trees, buildings, or other obstructions. Point plane away from face when launching. **DO NOT** fly in temperatures below 45°F/7°C. In these low temperatures, the wings will become brittle, and engine performance is severely decreased. **DO NOT** fly in rain, electrical storms, snow, or other adverse weather conditions. Use only the pump included in this package. Other pumps may damage the plane or lead to injury. Never pump anything except air into the engine. **DO NOT** leave air in plane. After your last flight, spin the propeller to make sure all the air has been used up.

ADULT SUPERVISION RECOMMENDED.

PROBLEM	CAUSE	SOLUTION
Engine with not start.	<ol style="list-style-type: none"> 1. No air in AIR TANK. 2. Sky Shark™ AIR INTAKE or PUMP NOZZLE is clogged with dirt. 	<ol style="list-style-type: none"> 1. Pump up Sky Shark™. 2. Clean out opening with a toothpick and re-pump.
Sky Shark™ does not have a level flight path.	<ol style="list-style-type: none"> 1. HORIZONTAL TAIL FLAPS not adjusted properly. 	<ol style="list-style-type: none"> 1. Re-adjust HORIZONTAL TAIL FLAPS. Bend TAIL FLAPS up to climb, and bend TAIL FLAPS down to prevent stalling.
Sky Shark™ AIR INTAKE will not fit into PUMP NOZZLE.	<ol style="list-style-type: none"> 1. Check for dirt in Sky Shark™ AIR INTAKE or PUMP NOZZLE. 	<ol style="list-style-type: none"> 1. Clean out AIR INTAKE and PUMP NOZZLE with a toothpick.
WINGS on your Sky Shark™ are damaged.		<ol style="list-style-type: none"> 1. Repair the WINGS with clear tape.

WARRANTY (U.S.A.)

Spin Master Ltd. warrants to the original consumer purchaser, that this product is thoroughly tested and inspected before shipment and is guaranteed to be free of factory defects in materials and workmanship for thirty (30) days (unless specified in alternate warranties) from the date of purchase.

In the event of such a defect within the warranty period, Spin Master Ltd., at our sole option, will repair or replace the product or provide you with another product of equal value. Repair or replacement shipment is free of charge. Shipping replacement may take 2 to 6 weeks, depending on customer's location.

In the event of a defect covered under this warranty, please call the toll-free number listed below. Many problems can be solved in this manner. If necessary, you will be instructed to return the defective part or unit, packed securely, postage prepaid and insured by the customer, to the address below. Enclose your name, address, dated sales receipt, and a brief explanation of the defect. There may be an additional handling charge if you send the entire toy.

The warranty is valid if and only if the product has been operated in accordance with the instructions. This warranty does not cover worn or defective batteries, damage resulting from neglect, unauthorized modification, accident, misuse, abuse, any action or omission which constitutes a deviation from the instructions or from the use of accessories or parts not manufactured by Spin Master Ltd. If the product is returned without a dated sales receipt the product is excluded from coverage under this warranty.

Spin Master Ltd.'s liability for defects in material and workmanship under this warranty shall be limited to repair or replacement, at our sole option, and in no event shall we be responsible for accidental, consequential, or contingent damages (except in those states that do not allow this exclusion or limitation) or refunds. This warranty is exclusive, and is made in lieu of any express or implied warranty. This warranty is valid only for products sold in the U.S.A. This warranty gives you specific legal rights and you may have other rights, which vary from state to state. Some states do not allow the exclusion of incidental or consequential damages, so the above exclusions or limitations may not apply to you.

Spin Master Ltd. reserves the right to improve the design of any product without assuming any obligation to modify any product previously manufactured.

If you have a problem, please contact our Customer Care Centre below for help.

SPIN MASTER LTD.
 CUSTOMER CARE CENTRE
 450 Front Street West
 Toronto, Ontario M5V 1B6 CANADA
 TOLL-FREE NUMBER 1-800-622-8339
 (valid only in North America)
 Hours: 8:00 A.M. – 5:00 P.M.
 Eastern Time: Monday – Friday.

Air Hogs® is a registered trademark and
 Sky Shark XR6™ is a trademark of Spin Master Ltd.
 © 1998 Spin Master Ltd. All rights reserved.
 MADE IN CHINA.

Asst. #45130
 U.S. English REV 0

