

EPIC

Era

OWNER'S MANUAL

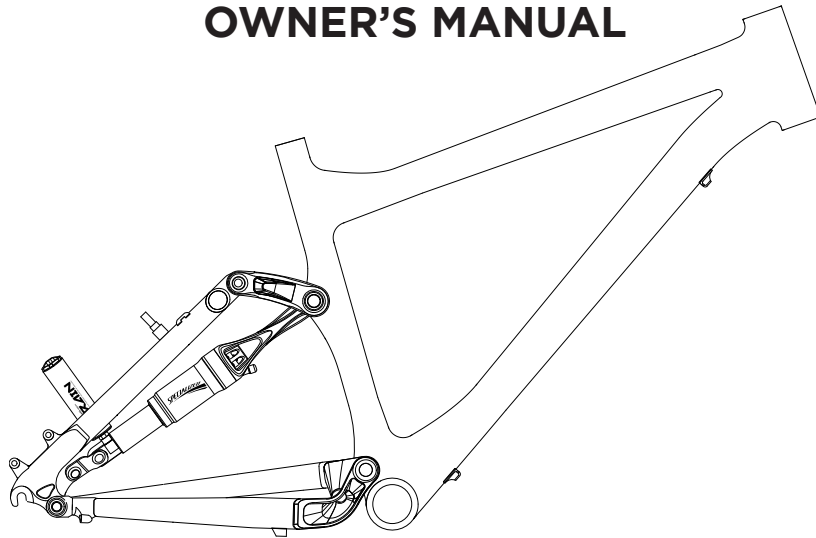

SPECIALIZED®

TABLE OF CONTENTS

Introduction.....	4
Fork Compatibility.....	6
Frame Features.....	7
Frame Geometry.....	8
Shock Setup.....	10
Optional Derailleur Guard Installation.....	11
Carbon Frame Instructions.....	12
Schematic and Specifications.....	14
Warranty.....	16

INTRODUCTION

Congratulations on your purchase and welcome to the finest line of suspension bikes available!

About Off Road, Stunt, Downhill and Freeriding

This manual is designed to be used in conjunction with the Bicycle Owner's Manual and owner's manuals supplied by the manufacturer of the front and rear suspension components. If you did not receive any of these manuals, download them from the Internet, contact your dealer, or contact us by telephone. There may be more current manuals and technical information available. For the most current information, regularly check the Specialized web site or consult your Specialized dealer. These manuals were written for an important reason: your safety while riding.

This manual contains many "Warnings" and "Cautions" concerning the consequences of failure to maintain or inspect your bicycle or of failure to follow safe cycling practices. The combination of the safety alert symbol and the word Warning indicates a potentially hazardous situation which, if not avoided, could result in serious injury or death. The combination of the safety alert symbol and the word Caution indicates a potentially hazardous situation which, if not avoided, may result in minor or moderate injury, or damage to your bicycle or a component. Because the consequences of not following a Warning usually include "you may lose control and fall," which could result in serious personal injury or death, we may not repeat this in conjunction with each Warning. Because it is impossible to anticipate every situation or condition which may occur, a practice or situation may be unsafe but not anticipated by this manual. So, don't forget to use your common sense.



WARNING! Make sure you have, review, and understand the warnings, instructions, and content of the manuals for your bicycle.

About Off Road, Stunt, Downhill and Freeriding

Downhill racing, severe off road riding, jumping, and stunt riding is extremely dangerous. Some downhill racers and freeriders reach speeds similar to motorcycles, thus face similar risks and hazards. When engaging in these activities, you, your bicycle and safety equipment must be in perfect condition. We recommend that at all times you wear appropriate safety gear, such as an approved full face helmet, full finger gloves, and body armor.

Not every bicycle is built for every activity. Check with your Specialized dealer to make sure you have the right equipment.

No bicycle is indestructible. Downhill racing, severe off road riding, jumping, and stunt riding increases the stress on every part of your bicycle. Frames or parts under high stress may fail, causing you to lose control or fall. Because of the risk involved, Specialized recommends that you conduct a thorough inspection before each ride. If you miss a jump, ditch your bike in mid crash, dump or launch your bike without you on it, inspect yourself for injury, then carefully inspect your bicycle for damage.

INTRODUCTION

Here is what you should look for when you inspect your bicycle for this type of riding: bent or broken components, such as the handlebar, handlebar stem, seatpost, pedals; dents, cracks, scratches, deformation, or discoloration. Because damage may be internal and hidden, if any of these signs are present, stop riding until your bicycle has been thoroughly inspected by your Specialized dealer.



WARNING! Although many catalogs, advertisements and articles about bicycling depict riders racing, jumping, riding hard off road, and/or stunt riding, this activity is extremely dangerous, increases the rider's risk of injury or death, and potentially increases the severity of any injury. The action depicted is being performed by experts with many years of training and experience. Even with that training and experience, cyclists who engage in such activity often get seriously injured. It is also foreseeable that during some jumps or stunts, and even some races, that the rider will exceed the design capacity of the frame or components, which may result in something on the bicycle bending or breaking. If a frame or component bends or breaks, such may lead to loss of control, serious personal injury or death.

As activities such as racing, jumping, severe off road riding, and stunt riding are extremely dangerous, SAFETY should always be the first consideration. Don't ride in the race, ride hard off road, try the jump, or do the stunt, **UNLESS YOU CAN DO SO SAFELY.** Here are some additional recommendations:

- Take lessons from a competent instructor first.
- Do jumps or stunts only in areas designated for this type of riding.
- Start with easy jumps and easy stunts first, and slowly develop skills before trying more dangerous jumps or stunts.
- Wear appropriate safety gear, such as a full face helmet, body armor, full finger gloves.
- Make sure by checking with your dealer that your bike is suitable for the kind of activity you intend to engage in.
- Constantly inspect your bicycle for signs of stress: cracks in the paint; dents; crushing or bending of the frame; bent components. Do not ride your bicycle if it shows such signs of stress.
- Do not seek to bend or break the frame or components. Remember, SAFETY FIRST!!!
- Understand and recognize that the stresses imposed on your bike by riding at speed, jumping or stunt riding may break or damage parts of the bicycle, which may result in loss of control, serious injury or death.

Specialized does not warrant the bicycle frame or components for such activities, and expressly disclaims all warranties, including the warranty of fitness for particular purpose and merchantability.

Stunt riding, severe off road riding, jumping, or riding downhill at speed is extremely dangerous, and the rider voluntarily assumes the risk that the bicycle frame and/or its components will bend or break, and voluntarily assumes the risk of injury or death.

INTRODUCTION

Service and Modifications

Technological advances have made bicycles and bicycle components more complex, and the pace of innovation is increasing. It is impossible for this manual or the accompanying manuals to provide all of the information required to properly repair and/or maintain your bicycle. In order to help minimize the chances of an injury, it is critical for you to have work performed by an authorized Specialized retailer.



WARNING! Service on Specialized bicycles requires special knowledge and tools. Specialized recommends that all service and repairs be performed by an authorized Specialized retailer.

Your bicycle has been engineered and tested with specific components and parts. Because of the great variety in these items, it is impossible for Specialized to test and approve of all possible combinations. Modifying the frame, fork, or any of the components may make your bike unsafe. For example, changing the front suspension on your bicycle may alter the steering characteristics and/or add stresses to the frame which have not been tested for. If you must replace any component, have this done by your authorized Specialized retailer.



WARNING! Never modify your frame or bicycle in any way. Do not sand, drill, fill, or remove parts. Do not install incompatible forks or suspension parts. An improperly modified frame, fork, or component, can cause you to lose control and fall.



Caution: Any modification of your frame, fork, or components means that your bike no longer meets our specifications and therefore voids your warranty.

FORK SETUP INFORMATION



WARNING! The Epic frame is compatible ONLY with single crown forks that have travel of 3.94" (100mm) or less. Use of different styled forks or forks with longer travel may result in catastrophic failure of the frame which may result in serious personal injury or death.

EPIC / ERA FRAME FEATURES

1. Main Frame
2. Seatstay
3. Chainstay
4. ↗-Link
5. Main Pivot
6. Dropout (Horst) Pivot
7. ↗-Link at Seatstay Pivot
8. ↗-Link at Frame Pivot
9. Lower Shock Eyelet
10. Upper Shock Eyelet
11. Shock
12. Replaceable Derailleur Hanger

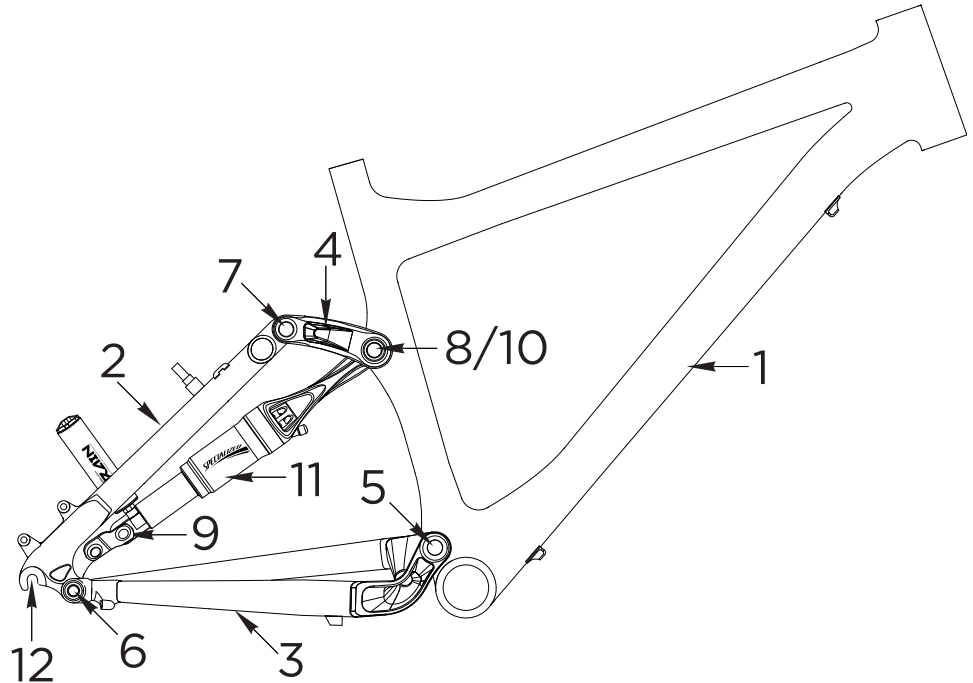

EPIC / ERA FRAME GEOMETRY

S-Works Epic Carbon Geometry

	Men's Small		Men's Medium		Men's Large		Men's X-Large	
1 *Top Tube Length	554mm	(21.81")	589mm	(23.19")	615mm	(24.21")	641mm	(25.24")
2 **Standover Hgt	762mm	(30.00")	769mm	(30.28")	788mm	(31.02")	791mm	(31.14")
3 Head Tube Length	124mm	(4.88")	136mm	(5.35")	146mm	(5.75")	176mm	(6.93")
4 Head Tube Angle	70.5°		70.5°		70.5°		70.5°	
5 Seat Tube Angle	74°		74°		74°		74°	
6 BB Height	331mm	(13.03")	331mm	(13.03")	331mm	(13.03")	331mm	(13.03")
7 Wheelbase	1058mm	(41.65")	1094mm	(43.07")	1120mm	(44.09")	1149mm	(45.24")
8 Chainstay Length	427mm	(16.81")	427mm	(16.81")	427mm	(16.81")	427mm	(16.81")

Epic M5 Geometry

	Men's Small		Men's Medium		Men's Large		Men's X-Large	
1 *Top Tube Length	554mm	(21.81")	589mm	(23.19")	615mm	(24.21")	641mm	(25.24")
2 **Standover Hgt	748mm	(29.45")	757mm	(29.80")	767mm	(30.20")	774mm	(30.63")
3 Head Tube Length	100mm	(3.94")	120mm	(4.72")	140mm	(5.51")	160mm	(6.30")
4 Head Tube Angle	70°		70°		70°		70°	
5 Seat Tube Angle	74.2°		74.2°		74.2°		74.2°	
6 BB Height	331mm	(13.03")	331mm	(13.03")	331mm	(13.03")	331mm	(13.03")
7 Wheelbase	1064mm	(41.89")	1100mm	(43.31")	1127mm	(44.37")	1155mm	(45.47")
8 Chainstay Length	427mm	(16.81")	427mm	(16.81")	427mm	(16.81")	427mm	(16.81")

Era Geometry

	Women's Small		Women's Medium		Women's Large		Headset: 1 1/8"	
1 *Top Tube Length	540mm	(21.26")	565mm	(22.24")	595mm	(23.43")	Seatpost diameter: 30.9mm	
2 **Standover Hgt	691mm	(27.20")	721mm	(28.39")	747mm	(29.41")	Front derailleur clamp: 34.9mm	
3 Head Tube Length	100mm	(3.94")	120mm	(4.72")	130mm	(5.12")	Seat Collar: 34.9mm	
4 Head Tube Angle	70°		70°		70°		Rear hub spacing: 135mm	
5 Seat Tube Angle	74.2°		74.2°		74.2°		BB shell: 73mm	
6 BB Height	331mm	(13.03")	331mm	(13.03")	331mm	(13.03")	Shock Stroke: 47.63mm (1.875")	
7 Wheelbase	1049mm	(41.30")	1076mm	(42.36")	1107mm	(43.58")	Eye to Eye: 307mm (12.09")	
8 Chainstay Length	427mm	(16.81")	427mm	(16.81")	427mm	(16.81")		

* TT length is the Horizontal Measurement from the center-line of the HT at the top of the HT to the center-line of the projected seat tube.

** Stand Over height is measured vertically at the centerpoint of the TT measurement.

EPIC FRAME GEOMETRY

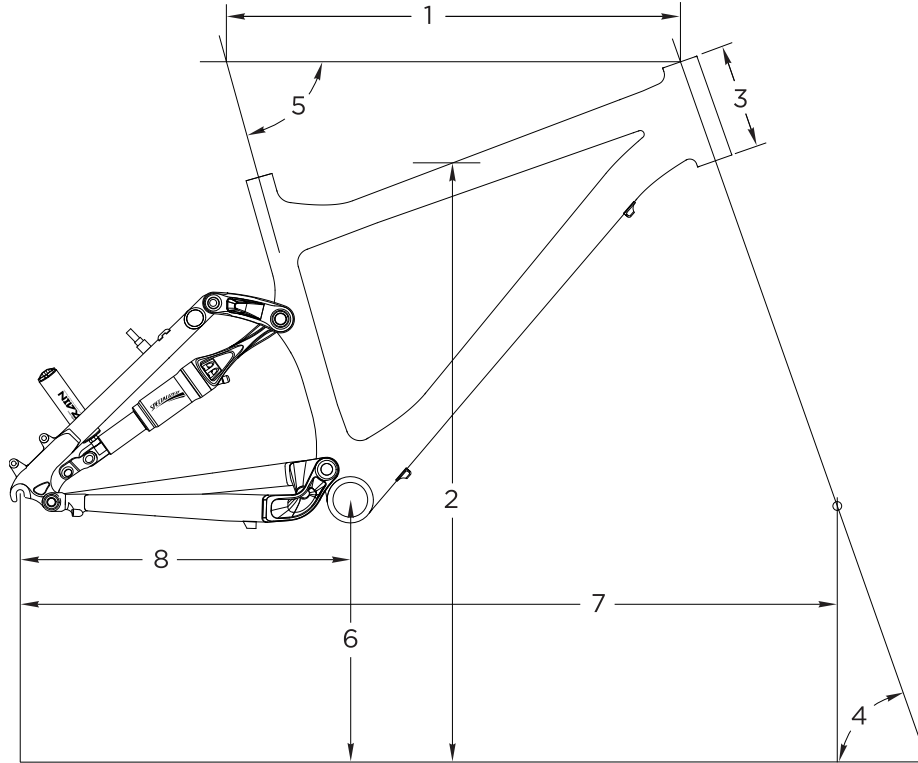

EPIC / ERA REAR SHOCK SETUP

1. Set sag:

- See the attached air chart for starting pressure. Use a high-pressure shock pump to add air.
- Turn the Brain Fade knob (3) counter-clockwise to allow the shock to sag more easily.
- Push the o-ring up to the seal, sit on/dismount the bike gently, measure the distance between the shock seal and the o-ring (sag).
- Adjust air pressure until the desired sag is reached (verify following the steps on page 6 or the measurements below the air chart).

Air pressures may vary depending on rider style and/or terrain.

2. Adjust rebound:

The red knob (2) controls the rebound damping, the rate which the shock returns after the shock has been compressed.

- Turn the knob clockwise for slower rebound (slower speed, bigger hits).
- Turn the knob counter-clockwise for faster rebound (higher speeds, small bumps, more traction).

3. Tune Brain Fade inertia valve:

Brain Fade is an inertia valve system offering a range of pedal platform efficiency. The blue knob (3) controls the Race Tune inertia valve damping.

- Turn the knob clockwise for a firmer, more efficient ride. Full clockwise is hardtail firm in smooth terrain.
- Turn the knob counter-clockwise for a softer, more supple Trail Tune setting.

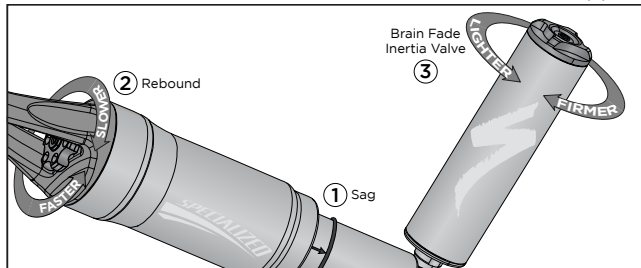

Eye-to-eye length: 307.3mm
Shock stroke: 47.6mm
Recommended sag: 20-25%
 (9.5-12mm)
Firm (race sag) setting: 15-20%
 (7.5-9.5mm)

Rider Weight lbs	(kg)	Air PSI
90-100	(41-45)	45-50
100-110	(45-50)	50-55
110-120	(50-54)	55-60
120-130	(54-60)	60-70
130-140	(60-64)	70-75
140-150	(64-68)	75-80
150-160	(68-73)	80-90
160-170	(73-77)	90-100
170-180	(77-82)	100-105
180-190	(82-86)	105-110
190-200	(86-91)	110-115
200-210	(91-95)	115-125
210-220	(95-100)	125-135
220-230	(100-104)	135-145
230-240	(104-109)	145-155
240-250	(109-113)	155-165
250-265	(113-120)	165-175
265-280	(120-127)	175-185
280-295	(127-134)	185-195

DERAILLEUR GUARD INSTALLATION

The Specialized Derailleur guard is available separately through your local Specialized dealer. The guard works with solid or Q/R axle types and is compatible with all Mountain bike models using the 2005-2006 Enduro/Demo derailleur hanger.

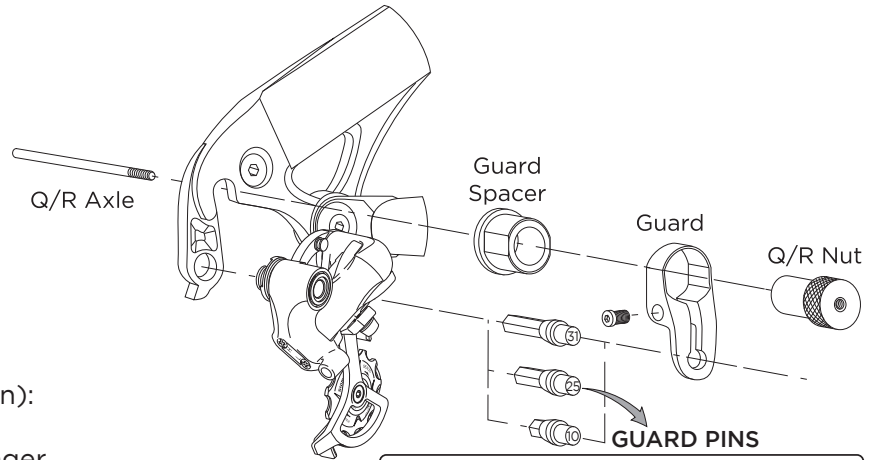

Guard Part #: 9896-4030

Hanger Part #: 9895-4021

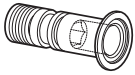

Derailleur Guard Installation (Q/R option):

1. Install rear derailleur on derailleur hanger.
2. Place rear wheel in frame and install Q/R, with springs and without Q/R end nut.
3. Insert appropriate derailleur guard pin in derailleur.
4. Place guard sleeve in derailleur guard.
5. Slide derailleur guard and sleeve over guard pin and Q/R.
6. Install supplied Q/R nut and tighten Q/R.
7. Torque guard pinch bolt to 80 in-lbf (9 N-m).

	Long (31mm): All SRAM derailleurs
	Medium (25mm): Shimano XTR / XT / LX (All Shimano derailleurs with countersunk hanger bolt)
	Short (10mm): (All Shimano derailleurs without countersunk hanger bolt)

EPIC / ERA FSR CARBON INSTRUCTIONS

The Specialized Epic Carbon frame utilizes advanced composite materials that require particular care during assembly, storage and riding. This installation and care guide contains instructions and warnings, plus torque specifications. Assembling a complete bicycle is a complicated task requiring training and experience, only a trained and experienced bicycle mechanic should install components to this frame. Reference should also be made to Barnett's or some other comprehensive bicycle manual.



WARNING! Failure to follow these instructions may result in a catastrophic failure of the frame and/or its components while riding, which may result in serious personal injury or death.



WARNING! Bicycle assembly is an art which requires training and experience. Do not attempt installation of any component if you do not have experience and training as a bicycle mechanic.

To ensure the best assembly possible and to prevent any damage to the components or frame, follow all torque specifications. Please refer to the specific owner's manuals for mating component's correct torque specifications. If the mating component's recommended torque exceeds the frame's recommended torque, use the lower torque spec. Due to torque considerations, not all components will be compatible.



WARNING! Failure to follow the torque specifications in this installation guide will void your warranty, but most importantly may result in damage to the frame which may not be visible. If the frame is damaged, this can result in loss of structural integrity.

Bicycle components such as a handlebar, handlebar stem, seat post, saddle, brakes, must be mutually compatible with each other, as well as the frame and the intended use. Any doubt regarding compatibility should be discussed with your local authorized Specialized retailer.



WARNING! When placing the frame and/or bicycle in a repair stand, clamp the stand to the seat post and not the frame. Clamping the frame can cause damage to the frame that may or may not be visible, which may impair the structural integrity of the frame.

SEAT POST

Refer to your seat post owner's manual prior to installation. Specialized Mountain frames have a 30.9mm seat post diameter and require that the seat post have a tolerance of 30.78mm to 30.95mm. **Do not grease inside surface of carbon seat tube!**

The Epic Carbon frame uses a bolt-style seat post clamping mechanism. Since the components of this assembly are in direct contact with carbon fiber, pay special attention to ensure proper tightness for the seat post when correctly tightened to specifications.

Specialized recommends the application of carbon assembly compound between the seat tube and post to increase friction. Recommended compounds can be found at www.tacx.com. See your authorized Specialized retailer if you have any questions.

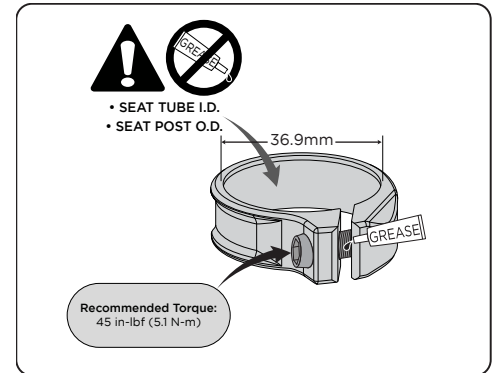



WARNING! Do not extend seat post above the minimum insertion line. Extension beyond the minimum insertion line can result in failure, causing serious injury or death.



WARNING! Do not pull down on downtube derailleur cables to pre-stress the cables. This can cause damage to the cable guides.

Your Specialized frame does not require any Bottom Bracket or Head Tube pre-installation preparation. All surfaces are already prepared from the factory, with the exception of greasing the bottom bracket threads and head set cups. It is acceptable to chase the bottom bracket threads if necessary. Do not face bottom bracket cups.

BOTTOM BRACKET

Ensure that the Bottom Bracket shell threads are clean and greased prior to installation. **Recommended torque is 442 in-lbf (50 N-m).**

HEADSET INSTALLATION / REMOVAL

Specialized mountain carbon frames use 48mm Campagnolo Standard compatible bearings. Ensure that replacement bearings are compatible with the Specialized headset specification. No tools are needed for installation or removal of Campagnolo Standard bearings. **Grease bearing surfaces before installation.**

COMPONENT TORQUE SETTINGS

- **Front derailleur:** Recommended torque is 44 in-lbf (5.0 N-m).
- **Rear derailleur:** Recommended torque for the rear derailleur is 70 in-lbf (7.9 N-m). Ensure that threads are clean prior to installation.
- **Seat collar:** Recommended torque is 45 in-lbf (5.1 N-m).
- **Water Bottle Cage:** Recommended torque is 35 in-lbf (4.0 N-m). To avoid damage to the bottle cage frame rivets, ensure that the cage doesn't flex around the front derailleur clamp. If the cage doesn't clear the clamp, use longer bolts and spacers to help the cage clear the derailleur clamp.

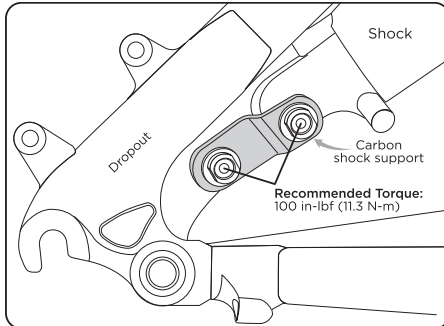

LOWER SHOCK EYE CARBON SUPPORT



WARNING! Great care should be taken to not damage carbon fiber or composite materials, including the frame and any carbon fiber or composite components. Any damage may result in a loss of structural integrity, which may result in a catastrophic failure. This damage may or may not be visible in inspection. Before each ride, and after any crash, you should carefully inspect your bicycle for any dents, fraying, gouging, scratches through the paint, chipping bending, or any other signs of damage. Do not ride if your bicycle shows any of these signs. After any crash, and before you ride any further, take your bicycle to an authorized Specialized retailer for a complete inspection.

Schematic #15

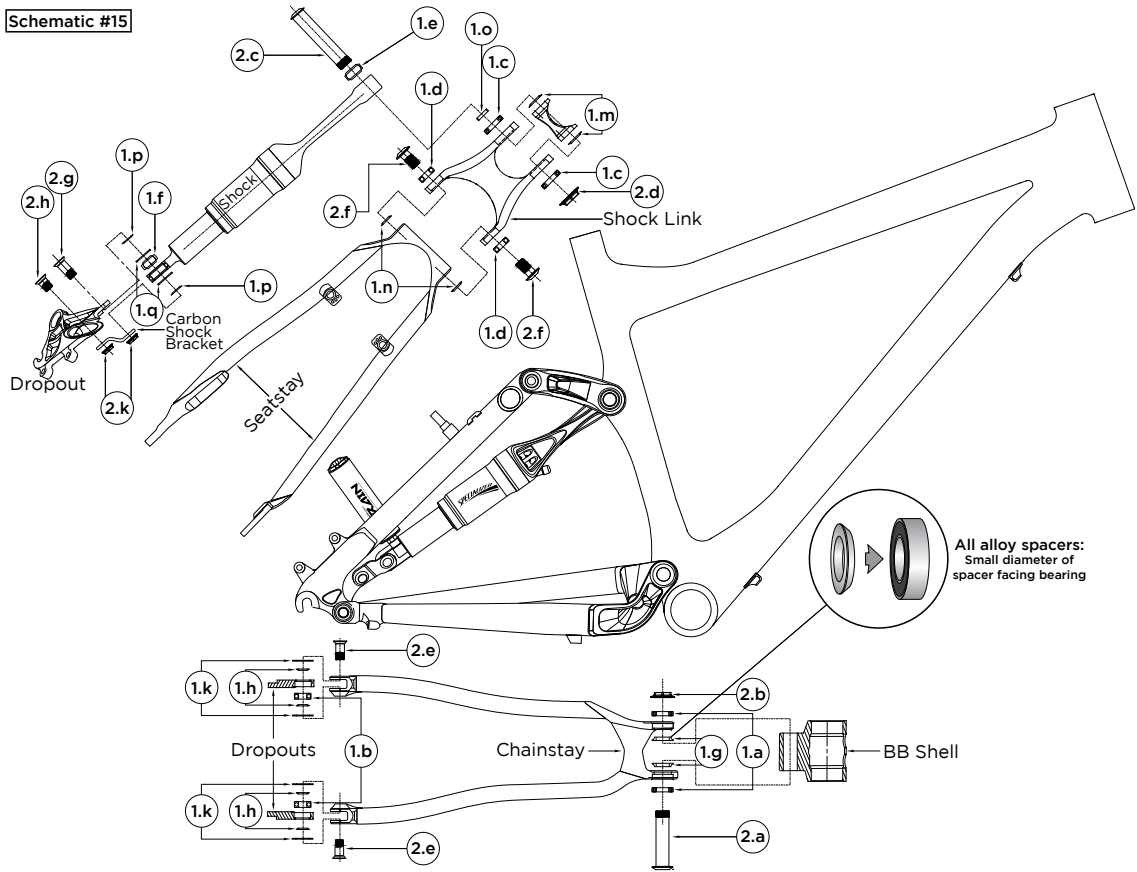

NOTE: Bearing and Bolt Kits are available only through your local Specialized dealer. To retain your warranty and for your safety, all maintenance should be performed by your local Specialized dealer.

Bearing Kit Parts

Part #	Qty.	Part Description	Part Specification
1.a	2	BB Pivot Bearing	6802 RS Series Full Complement Bearing - 24mm O.D. x 15mm I.D. x 5mm Width
1.b	2	Dropout Pivot Bearing	6800-2RS Series Bearing - 19mm O.D. x 10mm I.D. x 5mm Width
1.c	2	Shock Link @ Frame Pivot Bearing	6802 RS Series Full Complement Bearing - 24mm O.D. x 15mm I.D. x 5mm Width
1.d	2	Shock Link @ Seatstay Pivot Bearing	6800-2RS Series Bearing - 19mm O.D. x 10mm I.D. x 5mm Width
1.e	1	Upper Shock Eye Spherical Bearing	GE15C-K1 Series Bearing - 22mm O.D. x 15mm I.D. x 6mm Flange Width x 7.5mm Ball Width
1.f	1	Lower Shock Eye Spherical Bearing	GE10C Series Bearing - 19mm O.D. x 10mm I.D. x 6mm Flange Width x 9mm Ball Width
1.g	2	BB Pivot Spacer	Alloy spacer - 20mm O.D. x 15mm I.D. x 3mm Width, Chamfered
1.h	4	Dropout Pivot Bearing Spacer	Alloy spacer - 16mm O.D. x 10mm I.D. x 2.5mm Width, Chamfered
1.k	4	Dropout Pvt Outer Plastic Thrust Washer	Plastic washer - 23mm O.D. x 16mm I.D. x 1mm Width
1.m	2	Shock Link @ Frame Pivot Spacer	Alloy spacer - 20mm O.D. x 15mm I.D. x 3mm Width, Chamfered
1.n	2	Shock Link @ Seatstay Pivot Spacer	Alloy spacer - 16mm O.D. x 10mm I.D. x 2.5mm Width, Chamfered
1.o	1	Upper Shock Eye Strut Washer	Alloy spacer - 20mm O.D. x 15mm I.D. x 4mm Width
1.p	2	Lower Shock Eye Washer	Steel Washer - 17mm O.D. x 10mm I.D. x 1mm Width, Chamfered
1.q	2	Lower Shock Eye Circlip	Black Steel Circlip - 19mm x 1.0mm (Fits 19mm Bearings)

Bolt Kit Parts

B = Blue Loctite required

Part #	Qty.	Part Description	Part Specification	Torque in'lb
2.a	1	BB Pivot Axle	Alloy Axle - M15 Thread (23.5mm Head O.D.) x 67.5mm Shaft Length, 8mm Allen Hex Head	200-230
2.b	1	BB Pivot Nut	Alloy Nut - 23.5mm O.D x M15 Thread, 19mm socket <i>(use 6-point 19mm socket only)</i>	200-230 B
2.c	1	Shock Link @ Frame Pivot Axle	Alloy Axle - M15 Thread (16.5mm Head O.D.) x 76mm Shaft Length, 8mm Allen Hex Head	200-230B
2.d	1	Shock Link @ Frame Pivot Nut	Alloy Nut - 23.5mm O.D x M15 Thread, 19mm socket <i>(use 6-point 19mm socket only)</i>	200-230
2.e	2	Dropout Pivot Bolt	Alloy Bolt - M10 Thread x 19mm Shaft Length, Counter Flat Head, 4mm Allen Hex Head	100-120 B
2.f	2	Shock Link @ Seatstay Pivot Bolt	Alloy Bolt - M10 x 18mm Shaft Length, 5mm Allen Hex Head	120-140 B
2.g	1	Lower Shock Eye Bolt	Alloy Bolt - M10mm x 20mm Shaft Length, Counter Flat Head, 4mm Allen Hex Head	100-120 B
2.h	1	Lower Shock Bracket Bolt	Alloy Bolt - M10mm x 7.3mm Shaft Length, Counter Flat Head, 4mm Allen Hex Head	100-120 B
2.k	2	Lower Shock Eye / Bracket Nut	Alloy Nut - M10 x 18mm O.D., 4.5mm Width	



SBC LIMITED WARRANTY

Specialized Bicycle Components, Inc. (“Specialized”), a California corporation located at 15130 Concord Circle, Morgan Hill, California 95037, makes the following Limited Warranty concerning Specialized bicycles and framesets:

LIMITED LIFETIME WARRANTY ON BICYCLE FRAMES AND FRAMESETS

Subject to the following limitations, terms and conditions, Specialized warrants to the original owner for the lifetime of the original owner of each new Specialized bicycle or frameset that the bicycle frame or frameset when new is free of defective materials and workmanship. The lifetime limited warranty is conditioned upon the bicycle being operated under normal conditions and use, and properly maintained. This limited warranty does not apply to paint/finish or components attached to the bicycle/frameset such as front forks, wheels, drive train, brakes, seatpost, handlebar and stem or any suspension related parts or components. Paint/finish, components attached to the bicycle/ frameset such as front forks, wheels, drive train, brakes, seatpost, handlebar and stem or any suspension related parts or components are covered under the limited one (1) year warranty. This warranty is void if the bicycle or frameset was not purchased new from or not properly assembled by an authorized Specialized dealer.

LIMITED ONE (1) YEAR WARRANTY ON COMPLETE BICYCLE

Subject to the following limitations, terms and conditions, Specialized warrants to the original owner of each new Specialized bicycle that this bicycle when new is free of defective materials and workmanship. This warranty shall expire one (1) year from the date of the original purchase from an authorized Specialized dealer and is conditioned upon the bicycle being operated under normal conditions and use, and properly maintained. This warranty is void if the bicycle was not purchased new from or not properly assembled by an authorized Specialized dealer.

LIMITED ONE (1) YEAR WARRANTY ON SUSPENSION ATTACHMENTS & SUSPENSION RELATED EQUIPMENT

Also subject to the following limitations, terms and conditions, Specialized warrants to the original owner of each new Specialized bicycle or frameset that the suspension attachment points, and suspension related equipment (including pivot points, bushings, shock units, front suspension forks, stays, plates, fasteners) when new are free of defective materials or workmanship. This warranty shall expire one (1) year from the date of the original purchase from an authorized Specialized dealer and is conditioned upon the bicycle being operated under normal conditions and use, and properly maintained. This warranty is void if the bicycle was not purchased new from or not properly assembled by an authorized Specialized dealer. Some branded suspension equipment may have additional warranty coverage offered by the specific manufacturer. Please check in your owner’s manual pack for information regarding these warranties or check with your authorized Specialized dealer for details.

ADDITIONAL CONDITIONS

This Limited Warranty is made only to the original owner of this new Specialized bicycle or frameset purchased from an authorized Specialized dealer, and it shall remain in force only as long as the original owner retains ownership of the Specialized bicycle. This Limited Warranty is not transferable. In order to exercise your rights under this limited warranty, the bicycle or frameset must be presented to an authorized Specialized dealer, together with a receipt, bill of sale or other appropriate written proof of purchase which identifies the bicycle or frameset by serial number. Should this bicycle, frameset or any part be determined by Specialized to be covered by this warranty, it will be repaired or replaced, at Specialized’s sole option, which will be conclusive and binding. The original owner shall pay all labor charges connected with the repair or replacement of all parts. Under no circumstances does this limited warranty include the cost of travel or shipment to and from an authorized Specialized dealer. Such costs, if any, shall be borne by the original owner. This limited warranty does not apply to normal wear and tear, nor to claimed defects, malfunctions or failures that result from abuse, neglect, improper assembly, improper maintenance, alteration, collision, crash or misuse. This warranty is null and void if the bicycle is used for racing, trick riding, ramp riding, jumping, riding hard off road, aggressive riding, riding on severe terrain, riding in severe climates, riding with heavy loads, commercial activities or similar activities. Such use may damage the bicycle, can cause serious personal injury or death, and in all cases void this warranty.



USEFUL PRODUCT LIFE CYCLE

Every Specialized bicycle and frameset has a useful product life cycle. The length of that useful product life cycle will vary with the construction and materials of the bicycle or frameset, the maintenance and care the bicycle or frameset receives over its useful product life cycle, and the type and amount of use the bicycle or frameset is subject to. Uses in competitive events, trick riding, ramp riding, jumping, aggressive riding, riding on severe terrain, riding in severe climates, riding with heavy loads, commercial activities and other types of non-standard use can dramatically shorten the useful product life cycle of a Specialized bicycle or frameset. Any one or a combination of these conditions may result in an unpredictable failure of a Specialized bicycle or frameset that would not be covered by this warranty. ALL SPECIALIZED BICYCLES AND FRAMESETS SHOULD BE PERIODICALLY CHECKED BY AN AUTHORIZED SPECIALIZED DEALER for indicators of stress and/or potential failure, including cracks, deformation, corrosion, paint peeling, dents, and any other indicators of potential problems, inappropriate use, or abuse. These are important safety checks and very important to help prevent accidents, bodily injury to the rider and shortened useful product life cycle of a Specialized bicycle or frameset.

Special Note regarding Composite Frames and Components: Composite materials develop their strength and maintain strength only if the integrity of the part is fully maintained. Pay special attention to, and periodically and carefully inspect composite frames and components for signs of dents, fraying, gouging, scratches, fracture lines, chipping. In the event of a crash or serious impact, or if any of the foregoing signs are observed, the component and frame should not be ridden until inspected by an Authorized Specialized Dealer. For your safety, Specialized recommends replacing composite handlebars after three years of use.

THIS IS AN INTEGRATED AND FINAL STATEMENT OF SPECIALIZED'S LIMITED WARRANTY. SPECIALIZED DOES NOT AUTHORIZE OR ALLOW ANYONE, INCLUDING ITS AUTHORIZED DEALERS, TO EXTEND ANY OTHER WARRANTIES, EXPRESS OR IMPLIED, FOR SPECIALIZED. NO OTHER REPRESENTATION, AND NO STATEMENT OF ANYONE BUT SPECIALIZED, INCLUDING A DEMONSTRATION OF ANY KIND BY ANYONE SHALL CREATE ANY WARRANTY REGARDING THIS BICYCLE OR FRAMESET. ALL OF THE REMEDIES AVAILABLE TO THE ORIGINAL OWNER ARE STATED HEREIN. IT IS AGREED THAT SPECIALIZED'S LIABILITY UNDER THIS LIMITED WARRANTY SHALL BE NO GREATER THAN THE AMOUNT OF THE ORIGINAL PURCHASE PRICE AND IN NO EVENT SHALL SPECIALIZED BE LIABLE FOR INCIDENTAL OR CONSEQUENTIAL DAMAGES.

DISCLAIMER

All other remedies, obligations, liabilities, rights, warranties, express or implied, arising from law or otherwise, including but not limited to, any claimed implied warranty of merchantability, any claimed implied warranty arising from course of performance, course of dealing or usage of trade, and any claimed implied warranty of fitness, are disclaimed by Specialized and waived by the original owner. Some states, jurisdictions, countries, provinces, do not allow some or all of the limitations set forth herein, or the exclusion or limitation of incidental or consequential damages. If any provision is found unenforceable, only that provision shall be stricken and all others shall apply. This limited warranty does provide the original owner with certain legal rights and recourse and the original owner may possess other rights or recourse, depending on the state, jurisdiction, country or province.

2Bliss; 415; A1; AA Main; Aerotec; Air Force; Airliner; Air Lock; Air Tool; Air Wave; Air Wave Mega; Allez; Armadillo; Assfault; Beadlock; BigHit; BigHit Grom; Body Geometry; BrainTrust; Big Mouth; Cap Ply; Chamonix; Comfort Plush; Crossroads; Demo 9; Deuce; Dirt Bag; Dirtboy; Dirt Control; Dirt Master; Dirt Rodz; Dolce; E5; E Cage; Epic; Evil Twin; Expedition; Extreme Control; Extreme Master; F.A.C.T.; Fatboy; FlakJacket; Flexflo; ForeArm; FSR; FSRxc; FS-Xpert; Fuse; Globe; Ground Control; Ground Force; Hardlock; Hardlock Rapper; Hardrock; Hardrock'r; Hemi; Hotrock; Hucker; In Vent; Itch Switch; KidTrust; Kid Cobra; King Cobra; Langster; Little Big Mouth; LSD; M1; M2; M4; M5; Mini-Wedgie; Mt. Baldy; Mondo; Mountain Cage; Mouthport; Nimbus; P1; P.2.; P.3; P.Brain; P. Street; Pave; Prybaby; Rib Cage; Rockhopper; Roll Model; Roll X; Roubaix, the Stylized "S" logo; S-Works; S1; Sawpit; Sequoia; Shocksox; SIRRUS; Spanky; Speed Zone; Streetboy; Strongarm; Stumpjumper; SubZero; Survival Kit; Tarmac; Team Control; Team Master; Team Turbo; TrailTraction; TransForm; Tri-Sport; TRX; TR-Xpert; Turbo Pro; Twistlock; Vegas; Web; Wedgie; Wedlock; X-Brace; X-Wire; and Zertz are trademarks of Specialized Bicycle Components, Inc. which may be registered in some jurisdictions. All other marks are the property of their respective owners.



SPECIALIZED[®]

15130 Concord Circle
Morgan Hill, CA
95037

www.specialized.com

© 2008 Specialized Bicycles
PN# W2080309

SPECIALIZED BICYCLE COMPONENTS

15130 Concord Circle, Morgan Hill, CA 95037 (408) 779-6229

Please note all instructions are subject to change for improvement without notice.
Rev.1, April 2007