

Safety Instructions & Operator's Manual for

SNAPPER®

TWO STAGE LARGE FRAME SNOW THROWER SERIES 6



| MODELS | |
|---------------|---------------|
| 8246 9266E | 9266 11306 |

MODEL NUMBER EXPLANATION

| | | | |
|---|----|---|---|
| 9 | 26 | 6 | E |
|---|----|---|---|

ENGINE HP _____

AUGER WIDTH _____

ELECTRIC START _____

SERIES DESIGNATION _____

| | | |
|--|----------------------|------------------------|
| 8 – 8.0 Engine HP (Engine Horse Power) | 24 – 24" Auger Width | 6 – Series Designation |
| 9 – 9.0 Engine HP (Engine Horse Power) | 26 – 26" Auger Width | E – Electric Start |
| 11 – 11.0 Engine HP (Engine Horse Power) | 30 – 30" Auger Width | |

Thank you for buying a SNAPPER Product! Before operating your Snow Thrower, read this manual carefully and pay particular attention to the "IMPORTANT SAFETY INSTRUCTIONS" on Pages 2 & 3. Remember that all power equipment can be dangerous if used improperly. Also keep in mind that SAFETY requires careful use in accordance with the operating instructions and common sense.

SNAPPER® McDonough, GA., 30253 U.S.A.



IMPORTANT SAFETY INSTRUCTIONS



WARNING: This powerful machine is capable of amputating hands and feet and can throw objects that can cause injury and damage! Failure to comply with the following instructions may result in serious injury to the operator or other persons. The owner of the snow thrower must understand these instructions and, furthermore, must allow only persons who understand these instructions to operate snow thrower. Each person operating the snow thrower must be of sound mind and body and must not be under the influence of any substance which might impair vision, dexterity, or judgment. If you have any questions pertaining to your snow thrower which your dealer cannot answer to your satisfaction, call or write the Customer Service Department at SNAPPER, McDonough, Georgia 30253. Phone: 800/935-2967.

PROTECTION FOR CHILDREN

Tragic accidents can occur if the operator is not alert to the presence of children. Children are often attracted to the machine and the snow removal activity. Never assume that the children will remain where you last saw them.

1. **DO NOT** allow children in the area when snow thrower is being operated.
2. **DO NOT** allow pre-teenage children to operate snow thrower.
3. **ALLOW** only responsible adults and teenagers with mature judgment to operate the machine and then only after being thoroughly instructed and under the close supervision of an experienced adult operator.
4. Keep the area clear of all persons, particularly small children and pets.
5. Know how to **STOP** the snow thrower and disengage the controls quickly.

PREPARATION

1. Warn everyone in advance to stay clear of area. Keep especially watchful for children and pets darting into area while operating.
2. Read, understand, and follow instructions and warnings in this manual and on the machine. Know the controls and the proper use of the snow thrower before starting.
3. Data indicates that operators, age 60 and above, are involved in a large percentage of snow thrower-related injuries. These operators should evaluate their ability to operate the snow thrower safely enough to protect themselves and others from serious injury.
4. Disengage all clutches and shift into neutral before starting the engine (motor).
5. Wear adequate winter clothing including boots which will give you maximum footing on slippery surfaces. Exercise **CAUTION** to avoid slipping or falling.
6. Before the first snow fall, check the area to be cleared and remove all objects such as doormats, sticks, toys, wires, rocks, etc., which could be hurled or jam the snow thrower

PREPARATION

(Continued From Previous Column)

7. Survey the area to be cleared beforehand and plan where snow is to be blown. Be prepared to release auger/impeller clutch or to change discharge chute direction quickly to discharge away from windows, cars, buildings and doorways to avoid property damage or personal injury from hurled objects.
8. Use only approved extension cords and receptacles in good condition and with sufficient capacity to carry the current to the machine if equipped with electric starting motors.
9. Handle fuel with extra care. Fuels are flammable and vapors are explosive. Store only in an approved fuel container. Never remove fuel cap or add fuel with the engine running. Add fuel outdoors only with the engine stopped and cool. Clean spilled fuel and oil from machine. **DO NOT** smoke. **DO NOT** run engine indoors.

OPERATIONAL PRECAUTIONS

1. Before starting, make visual check to make sure auger/impeller housing is clear and all guards and shields are in place and tight.
2. **DO NOT** operate machine without proper guards shields, deflectors, or other safety protective devices in place and functioning properly.
3. Should the auger/impeller become clogged, release the auger/impeller clutch control and, as an additional precaution, **STOP** the engine before attempting to unclog the auger/impeller or discharge chute.
4. **DO NOT** attempt to unclog the auger/impeller or discharge chute by reaching in with your hands. Use a long stick or similar implement to unclog.
5. **DO NOT** attempt to unclog the auger/impeller or discharge chute with the engine running. **STOP** engine and remove key.
6. **STOP** engine (motor) and remove key before leaving the operator position for any reason.



IMPORTANT SAFETY INSTRUCTIONS



OPERATIONAL PRECAUTIONS

(Continued From Previous Page)

7. DO NOT put hands or feet near or under rotating parts. Keep clear of the discharge opening at all times.
8. Start engine only where exhaust fumes will be safely dissipated. Allow a brief warm-up period, and practice operation of controls outside before putting the machine to work.
9. After striking a foreign object, STOP the engine (motor), remove the key, and remove the wire from spark plug. Thoroughly inspect the snow thrower for any damage, and repair the damage before restarting and operating the snow thrower.
10. STOP the engine if the machine starts to vibrate excessively as this normally indicates mechanical problems. Remove the key and disconnect the spark plug wire to prevent unintentional starting before servicing or repairing the machine.
11. DO NOT clear snow across the face of slopes. Exercise extreme CAUTION when changing direction on slopes. DO NOT attempt to clear steep slopes.
12. DO NOT leave machine unattended with the engine running. STOP engine and remove key to prevent unauthorized operation.
13. Release clutch control and make sure auger/impeller has STOPPED before adjusting deflector, or placing hands near auger/impeller.
14. DO NOT use snow thrower on surfaces above ground level, such as, a roof of a building.
15. Exercise extreme CAUTION when operating on or crossing gravel drives, walks, or roads. Stay alert for hidden hazards or traffic.
16. DO NOT overload the machine capacity by attempting to clear snow at too fast a rate.
17. Never operate the machine at high transport speeds on slippery surfaces. Look behind and use care when backing.
18. Disengage power to the auger/impeller when snow thrower is transported or not in use.
19. Use only attachments and accessories approved by the manufacturer of the snow thrower (such as wheels weights, counterweights, cabs and the like).
20. Never operate the snow thrower without good visibility or light. Always be sure of your footing, and keep a firm hold on the handles. Walk; never run.

SAFE HANDLING OF GASOLINE

To avoid personal injury or property damage, use extreme care in handling gasoline. Gasoline is extremely flammable and the vapors are explosive

1. Extinguish all cigarettes, cigars, pipes and other sources of ignition.
2. Use only an approved fuel container.

3. DO NOT remove fuel cap or add fuel with the engine running. Allow the engine to cool before refueling.
4. DO NOT refuel the machine indoors.
5. DO NOT store the machine or fuel container inside where there is an open flame, spark or pilot light such as on a water heater or other appliances.
6. DO NOT fill fuel containers inside a vehicle or on a truck or trailer bed with a plastic liner. Always place the containers on the ground away from the vehicle before filling.
7. Remove gas-powered equipment from the vehicle or trailer and refuel it on the ground. If this is not possible, then refuel equipment using a portable container, rather than a gasoline dispenser nozzle.
8. DO NOT start gas powered equipment in enclosed vehicles or trailers.
9. Keep the nozzle in contact with the rim of the fuel tank or container opening at all times until fueling is complete. DO NOT use a nozzle lock-open device
10. If fuel is spilled on clothing, change clothing immediately.
11. Never overfill a fuel tank. Replace fuel cap and tighten securely.

MAINTENANCE AND STORAGE

1. DO NOT store machine or fuel container inside where fumes may reach an open flame, spark, or pilot light as in a water heater, furnace, clothes dryer or other gas appliance. Allow engine to cool before storing machine in an enclosure. Store fuel container out of reach of children in a well ventilated, unoccupied building.
2. Keep machine and engine free of excess oil, grease and spilled fuel to reduce fire hazard.
3. When draining fuel tank, drain fuel into an approved container outdoors and away from open flame.
4. Inspect all bolts, nuts and screws frequently and keep properly tightened.
5. Use only recommended shear bolts (if equipped) to prevent possible damage to machine.
6. Service engine and make adjustments only when engine is stopped. Remove key, remove wire from spark plug, secure wire away from plug, and disconnect cord from electric starting motors to prevent accidental starting.
7. DO NOT change engine governor speed settings or overspeed engine.
8. DO NOT test for spark by grounding the spark plug next to spark plug hole. Spark from the plug could ignite gas exiting engine.
9. Have machine serviced by an authorized SNAPPER dealer at least once a year and have the dealer install any new safety devices.
10. Use only genuine SNAPPER replacement parts to assure that original standards are maintained.

TABLE OF CONTENTS

| | |
|--|--------------|
| SECTION 1 - IMPORTANT SAFETY INSTRUCTIONS..... | 2-3 |
| TABLE OF CONTENTS | 4 |
| SECTION 2 - OPERATING INSTRUCTIONS..... | 5-10 |
| Introduction..... | 5 |
| Pre-start Checklist..... | 6-7 |
| Starting & Stopping Engine (Recoil Start Models)..... | 7-10 |
| Starting & Stopping Engine (Electric Start Models) | 9-10 |
| Starting & Stopping Auger/Impeller..... | 8-10 |
| Starting & Stopping Wheel Drive | 8-10 |
| Free Wheel Machine..... | 10 |
| SECTION 3 - MAINTENANCE INSTRUCTIONS..... | 11-12 |
| Checking Auger Drive Belt | 11 |
| Checking Wheel Drive Belt..... | 11 |
| Lubricate Gear Case..... | 11 |
| Lubricate Auger & Bearing | 11 |
| General Lubrication..... | 11 |
| Annually (End of Season) | 12 |
| Changing Engine Oil..... | 12 |
| Changing Spark Plug..... | 12 |
| Storage Procedure | 12 |
| Maintenance and Service Parts | 12 |
| SECTION 4 - ADJUSTMENTS AND REPAIR | 13-18 |
| Auger/Impeller & Wheel Drive Belt Adjustment..... | 13-14 |
| Auger/Impeller & Wheel Drive Belt Replacement..... | 14-15 |
| Skid Shoe Adjustment | 16 |
| Single Handle Control Adjustment | 17 |
| Auger Shear Bolt Replacement..... | 18 |
| Chute Crank Adjustment | 18 |
| Rubber Drive Tire Replacement..... | 18 |
| TROUBLESHOOTING | 19 |
| SERVICE SCHEDULE | 19 |
| WARRANTY AND PRODUCT REGISTRATION..... | 20-21 |

IMPORTANT

The figures and illustrations in this manual are provided for reference only and may differ from your specific model. Contact your Snapper dealer if you have questions.

Section 2 - OPERATING INSTRUCTIONS

1.1 INTRODUCTION

Before starting machine, visually check location of all operational controls and identify major parts discussed in Operator's Manual.

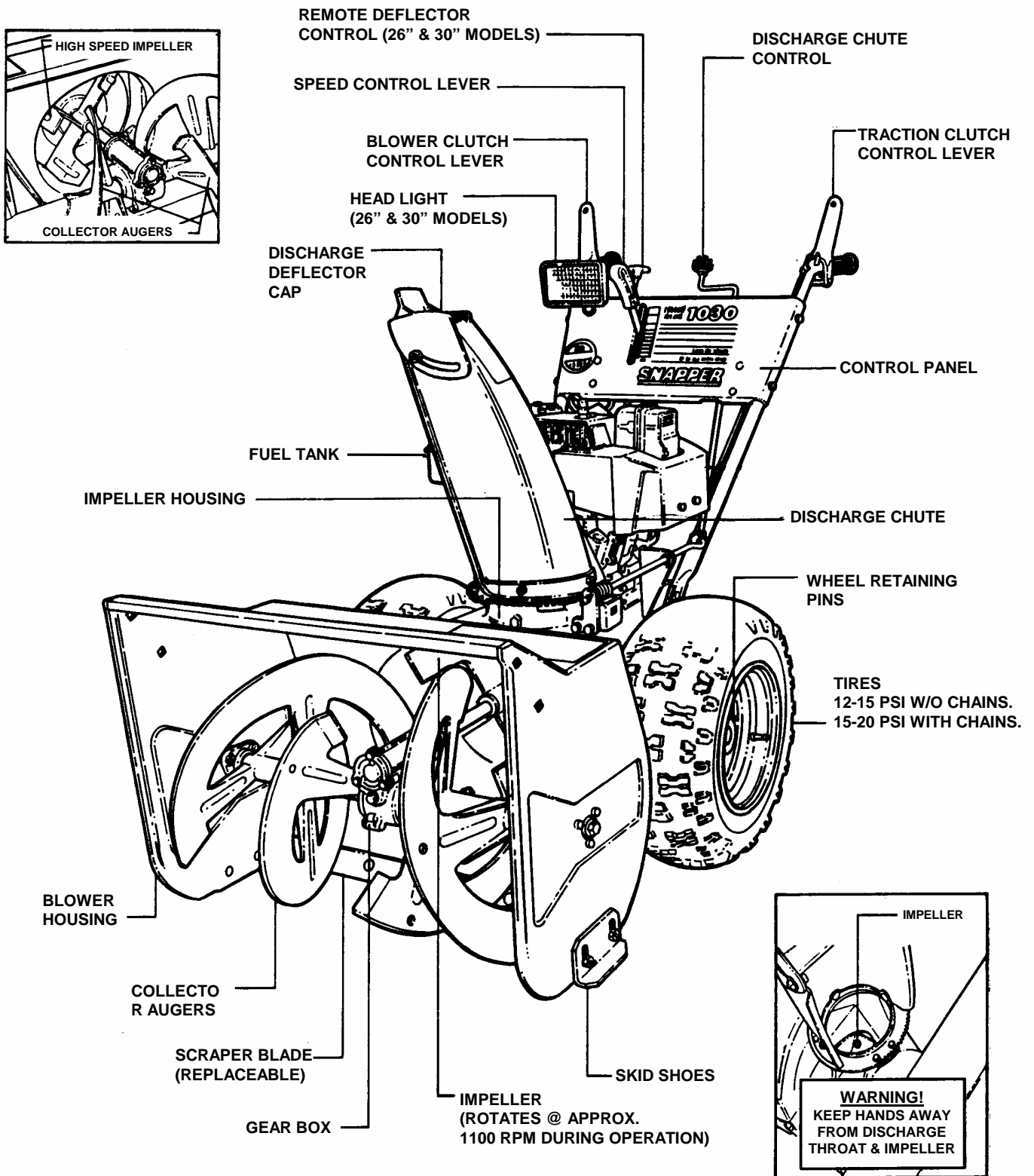

**FIGURE 1.1
NOMENCLATURE**

Section 2 - OPERATING INSTRUCTIONS

2.1 PRE-START CHECK LIST

Make the following checks and perform the service required before each start-up.

2.1.1. Check engine oil and add oil as needed to bring level up to the FULL mark. Refer to engine owner's manual for oil specifications.

2.1.2. Check guards, chutes, deflectors and covers to make sure all are in place and securely tightened.

2.1.3. Check auger/impeller control and wheel drive control to insure cables are connected and both levers operate freely. See Figure 2.1.

IMPORTANT: On 26" & 30" Auger models only. Standing in the operator's position, the left handle bar lever is for wheel drive engagement and disengagement. The right handle bar lever is for auger/impeller engagement and disengagement. Hold both levers down to handle bar for engagement and release levers for disengagement. When both levers are pressed down to the handle bar at the same time, the operator can release the right hand lever and the right lever will remain engaged as long as the left hand lever is held down to handle bar. Release the left hand lever and both levers will disengage.

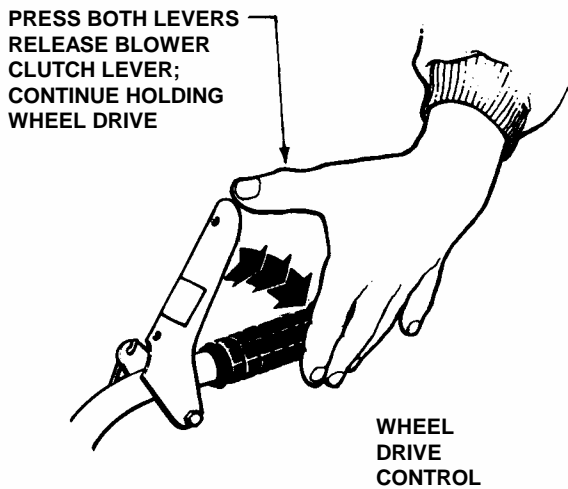

FIGURE 2.1

2.1.4. Check chute operation. Rotate chute crank to insure smooth rotation throughout its range. See Section 4.1.6. for worm gear adjustment.

2.1.5. Check tires and add or release air as needed to bring air pressure to 12 psi without tire chains. Air pressure with tire chains should be 16 psi.

IMPORTANT: Electric Start Kit optional accessory on some models.

⚠

WARNING

⚠

Use approved fuel container. DO NOT smoke near open fuel container. DO NOT fill fuel tank indoors or when engine is running. Allow engine to cool for at least ten minutes before refilling. Wipe off any spilled fuel before starting engine. DO NOT run engine indoors.

2.1.6. Add fuel to tank after pushing the machine outside where fumes can safely dissipate. Make sure cap is tightened after refueling. Wipe up any spilled fuel on machine and surrounding area. Refer to Engine Owners Manual for specifications.

2.1.7. Check auger/impeller housing and discharge chute, both must be free of all obstructions. Clean engine of any accumulation of spilled fuel, dirt, etc.

⚠

WARNING

⚠

DO NOT use an electrical extension cord that is damaged. A damaged electrical extension cord could cause a shock or fire. Thoroughly inspect electrical extension cord before using machine. If cord is damaged, do not use and do not operate machine. Replace damaged cord immediately. Contact your Snapper service dealer for assistance. To reduce the risk of electric shock, use only with an extension cord intended for outdoor use having a cord type: SW-A, SOW-A, STW-A, STOW-A, SJW-A, SJTW-A or SJTOW-A.

2.1.8. Check and make sure extension cord is in good condition. Extension cord should not have any broken insulation or exposed wires. Use an extension cord that is heavy enough to carry the correct amount of current to the machine. See Figure 2.2 for correct size to use depending on cord length and nameplate ampere rating. If in doubt, use the next heavier gauge cord.

| MINIMUM GAUGE FOR CORD SETS | | | | | |
|-----------------------------|---------------|------------------------------|--------|-----------------|---------|
| 120 or 230 Volt | | Total Length of Cord in Feet | | | |
| Rating - Amps | | 25 ft. | 50 ft. | 100 ft. | 150 ft. |
| More Than | Not More Than | A.W.G. | | | |
| 0 | 6 | 18 | 16 | 16 | 14 |
| 6 | 10 | 18 | 16 | 14 | 12 |
| 10 | 12 | 16 | 16 | 14 | 12 |
| 12 | 16 | 14 | 12 | Not Recommended | |

FIGURE 2.2

Section 2 - OPERATING INSTRUCTIONS

2.1 PRE-START CHECK LIST

2.1.9. Check the AC electrical outlet that will be used and make sure it is a polarized outlet. The machine has a polarized plug (one blade of plug is wider than the other) that will accept a polarized outlet (receptacle) only one way. If plug does not fit fully into your outlet, reverse the plug. If it still does not fit, contact a qualified electrician to install a proper polarized outlet. **DO NOT** modify or change this polarized plug in any way.

2.2 STARTING, OPERATION & STOPPING (RECOIL START MODELS)

2.2.1. ENGINE

1. Turn fuel shut off valve to the "ON" position. See Figure 2.3.

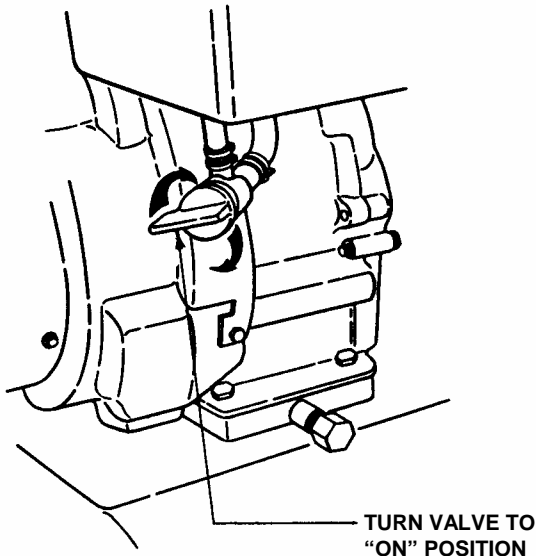

FIGURE 2.3

2. Insert key into ignition switch. See Figure 2.4.
3. Move choke control to the choke, "ON" position. See Figure 2.4.
4. Move engine speed control to the "FAST" position. See Figure 2.4.
5. Push primer three times to start a cold engine. **NOTE:** Do not use primer button to start warm engine. See Figure 2.4.

IMPORTANT: Stop the auger/impeller and wheel drive by releasing the auger/impeller and wheel drive control levers. Stop the engine by moving the engine speed control to stop or removing the key from the switch.

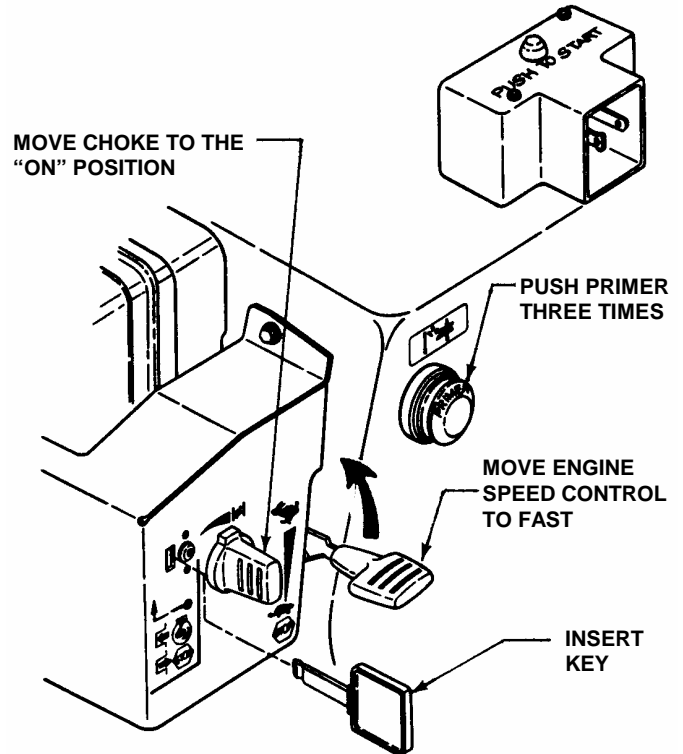

FIGURE 2.4

6. Pull rope start handle to crank engine.
7. After engine starts, move the choke control to the no choke, "OFF" position. Allow a brief warm-up until engine runs smooth.

(Continued on Next Page)

Section 2 - OPERATING INSTRUCTIONS

2.2 STARTING, OPERATION & STOPPING (RECOIL START MODELS)

(Continued From Previous Page)

2.2.2. PROPELLING SNOW THROWER

IMPORTANT: This snow thrower has six forward speeds and one reverse speed.

1. Move ground speed control to the desired speed position. See Figure 2.5.
2. Proceed to Section 2.2.4. to engage wheel drive.

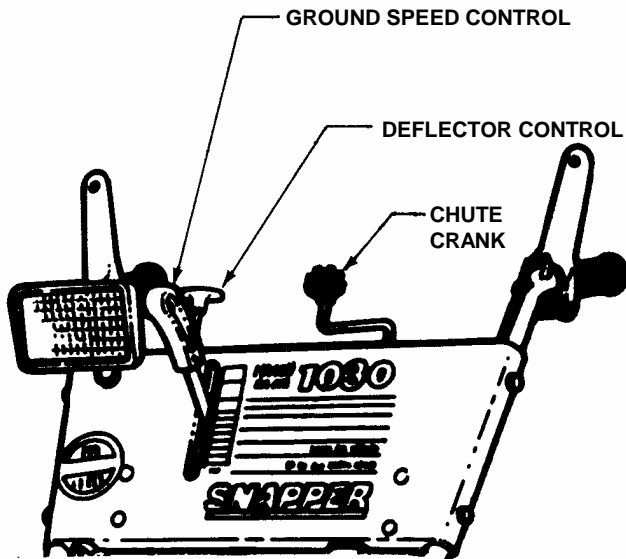

FIGURE 2.5

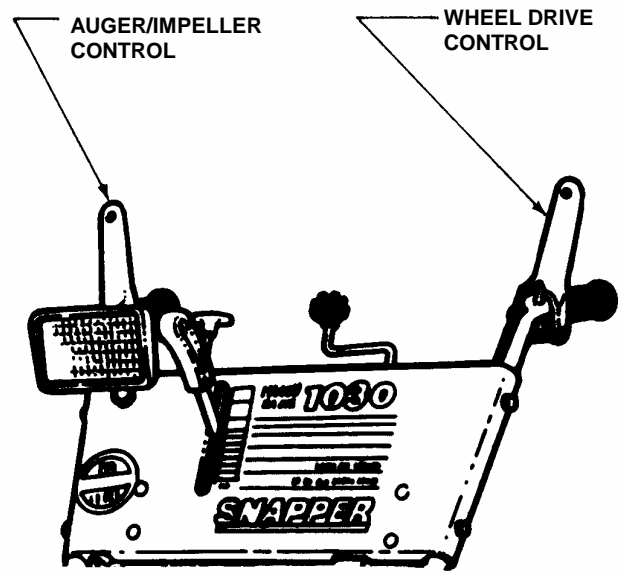



FIGURE 2.6

2.2.5. DISCHARGE CHUTE and DEFLECTOR ADJUSTMENT

1. Release auger/impeller control and wheel drive control levers to allow auger/impeller and ground speed to come to a complete stop.
2. Position the deflector in the desired location using deflector handle located on control panel. Rotate deflector handle counter clockwise to unlock. Push handle to raise or pull handle to lower the deflector. Rotate deflector handle clockwise to lock into position.
3. Rotate chute crank to position discharge chute in desired direction. Refer to Figure 2.5.

| | | |
|--|----------------|---|
|  | WARNING |  |
| <p>Objects can be thrown by the snow thrower while it is in operation. Thrown objects could cause serious injury to the operator or bystanders. Always wear safety goggles or other suitable eye protection. Keep people and pets away from area. Release auger/impeller clutch and wheel drive controls and make sure auger/impeller and wheel drive have STOPPED before rotating discharge chute, or adjusting deflector. DO NOT place hands near auger/impeller while engine is running</p> | | |

2.2.3. ENGAGING AUGER

1. Move auger/impeller control lever against handle to engage auger/impeller. See Figure 2.6.

2.2.4. ENGAGING WHEEL DRIVE

1. Move wheel drive control lever against handle to engage wheel drive. Ground speed can be changed while the machine is in operation by changing position of the ground speed control.
- IMPORTANT:** This snow thrower has six forward speeds and one reverse speed. See Figure 2.6.

Section 2 - OPERATING INSTRUCTIONS

2.2 STARTING, OPERATION & STOPPING (RECOIL START MODELS)

2.2.6. STOPPING - ENGINE, AUGER & WHEEL DRIVE

Stop the auger/impeller and wheel drive by releasing the auger/impeller and wheel drive control levers. Stop the engine by moving the engine speed control to the stop position or removing the key from the switch. Always remove key from key switch before leaving machine unattended. See Figure 2.7.

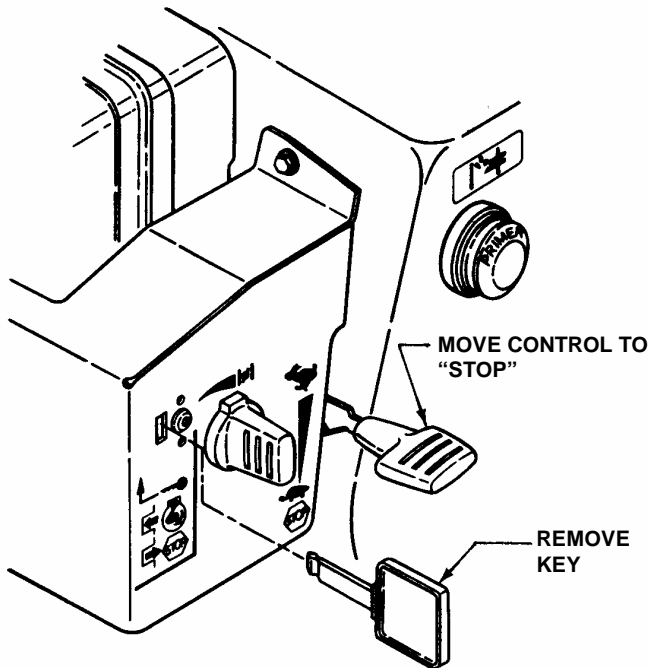

FIGURE 2.7

2.2 STARTING, OPERATION & STOPPING (ELECTRIC START MODELS)

WARNING

DO NOT use an electrical extension cord that is damaged. A damaged electrical extension cord could cause a shock or fire. Thoroughly inspect electrical extension cord before using machine. If cord is damaged, do not use and do not operate machine. Replace damaged cord immediately. Contact your Snapper service dealer for assistance. To reduce the risk of electric shock, use only with an extension cord intended for outdoor use having a cord type: SW-A, SOW-A, STW-A, STOW-A, SJW-A, SJTW-A or SJTOW-A.

2.2.7. ENGINE

1. Turn fuel shut off valve to the "ON" position. Refer to Figure 2.3.
2. Insert key into ignition switch. See Figure 2.8.
3. Connect the power cord to the starter switch box on the engine, then plug the other end into 120 volt AC receptacle.
4. Move choke control to the choke, "ON" position. See Figure 2.8.

IMPORTANT: Stop the auger/impeller and wheel drive by releasing the auger/impeller and wheel drive control levers. Stop the engine by moving the engine speed control to the stop position or removing the key from the switch.

5. Move engine speed control to the "FAST" position. See Figure 2.8.
6. Push primer button three times to start a cold engine. **NOTE:** Do not use primer button to start warm engine.
7. Push the electric starter button. DO NOT hold button for more than 20 seconds to avoid damaging the starting motor. See Figure 2.8.
8. After engine starts, move the choke control to the no choke "OFF" position. Allow a brief warm-up until engine runs smooth.
9. Disconnect power cord from AC receptacle. Disconnect power cord from machine and remove cord from area where machine will be in operation.

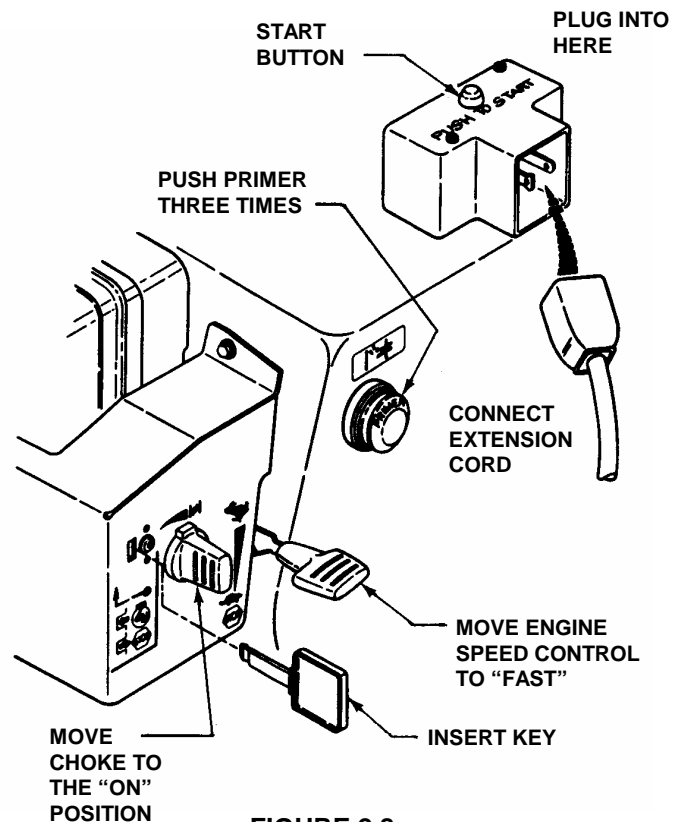



FIGURE 2.8

Section 2 - OPERATING INSTRUCTIONS

2.2 STARTING, OPERATION & STOPPING (ELECTRIC START MODELS)

(Continue From Previous Page)

| | | |
|---|----------------|---|
|  | WARNING |  |
| <p>Objects can be thrown by the snow thrower while it is in operation. Thrown objects could cause serious injury to the operator or bystanders. Always wear safety goggles or other suitable eye protection. Keep people and pets away from area.</p> | | |

2.2.8. ENGAGING AUGER

1. Pull auger/impeller control lever against handle to engage auger/impeller. Refer to Figure 2.6.

2.2.9. ENGAGING WHEEL DRIVE

1. Move wheel drive control lever against handle to engage wheel drive. Ground speed can be adjusted while the machine is moving by changing position of the ground speed control. Machine has six forward speeds and one reverse. Refer to Figure 2.5.

| | | |
|--|----------------|--|
|  | WARNING |  |
| <p>Release auger/impeller clutch control and make sure auger/impeller has STOPPED before rotating discharge chute, or adjusting deflector. DO NOT place hands near auger/impeller while engine is running.</p> | | |

2.2.10. DISCHARGE CHUTE and DEFLECTOR ADJUSTMENT

1. Release auger/impeller control and wheel drive control levers to allow auger/impeller and ground speed to come to a complete stop.
2. Position the deflector to the desired location using deflector handle located on control panel. Rotate deflector handle counter clockwise to unlock. Push handle to raise or pull handle to lower the deflector. Rotate deflector handle clockwise to lock into position.
3. Rotate chute crank to position discharge chute in desired direction. Refer to Figure 2.5.

2.2.11. STOPPING - ENGINE, AUGER & WHEEL DRIVE

Stop the auger/impeller and wheel drive by releasing the auger/impeller and wheel drive control levers. Stop the engine by moving the engine speed control to the stop position or removing the key from the switch. Always remove key from key switch before leaving machine unattended. Refer to Figure 2.7.

2.2.12. FREE WHEEL MACHINE

Snow Thrower can be transported without engine running and transmission drag.

1. Remove hair pins and clevis pins from both wheel axles. Remove wheels from axle. Apply a liberal amount of axle grease to the axle to allow the wheel to rotate freely.

2. Slide wheel inward toward main case.

3. Reinstall clevis pins and hair pins into outer holes to prevent wheel from sliding off of the end of axle. Wheels will rotate freely on axle. **IMPORTANT:** If engine is started the wheel drive will not operate unless wheels and axle are reconnected. Reinstall clevis pins and hair pins into holes in the hubs of the wheels and through axle. See Figure 2.9.

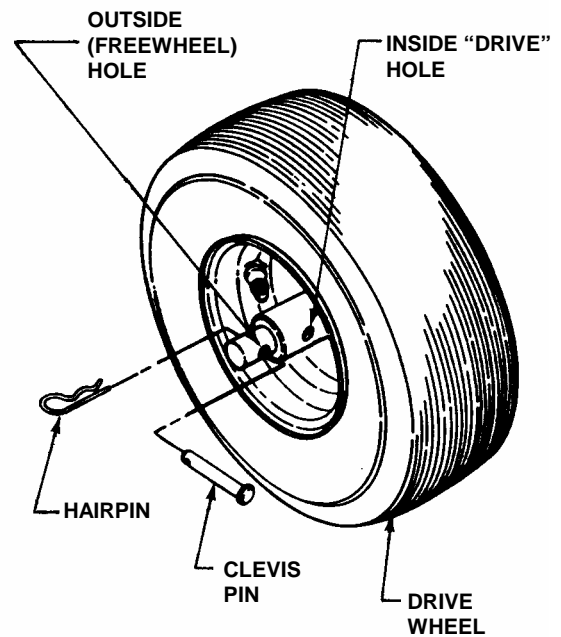

FIGURE 2.9

Section 3 - MAINTENANCE

3.1 INTRODUCTION

To retain the quality of the snow thrower, use only genuine SNAPPER replacement parts. Contact a local SNAPPER dealer for parts and service assistance. For the correct part or information for a particular snow thrower, always mention model and serial number.

3.2 SERVICE - AFTER FIRST 5 HOURS

3.2.1 CHECK AUGER DRIVE BELT

1. Visually check engine drive belt for cracking, fraying, severed or belt strands exposed. Replace belt before operating snow thrower. See Figure 3.1

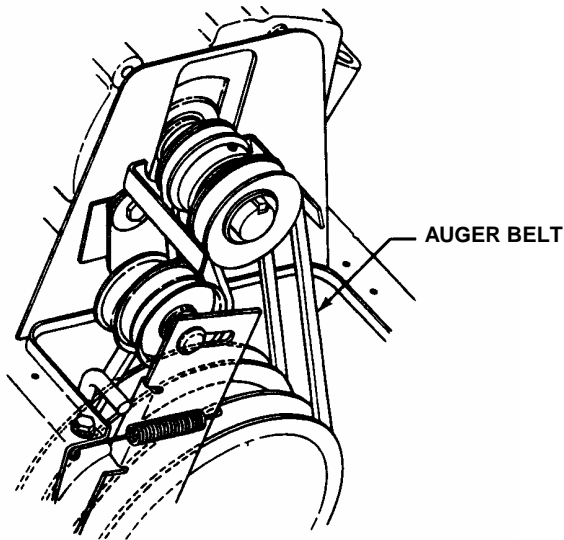

FIGURE 3.1

3.2.2 CHECK WHEEL DRIVE BELT

1. Visually check wheel drive belt for cracking, fraying, severed or belt strands exposed. Replace belt before operating snow thrower. See Figure 3.2.

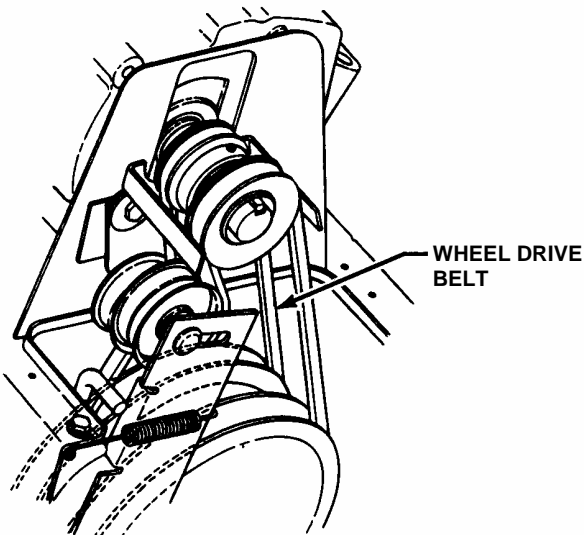

FIGURE 3.2

3.3 GENERAL LUBRICATION

Lubricate machine as instructed before and after operation each season.

3.3.1. GEAR CASE, AUGER SHAFT and AUGER BEARING LUBRICATION

1. Before each season of operation, apply two shots of grease from a grease gun into gear case. Snapper suggests using Benalene 900. The grease plug for the gear case is located in front of the gear case. See Figure 3.3.

2. Before each season of operation, apply two shots of grease from a grease gun into each auger bearing. Snapper suggests using Benalene 900. The grease fitting for the auger bearing is located on each end of the auger. See Figure 3.3.

3. Before each season of operation, apply two shots of general purpose grease from a grease gun into the auger shaft. The grease fitting for the auger shaft is located in the middle of each auger. Remove shear bolts and rotate auger to distribute grease evenly around shaft. Reinstall shear bolts and nuts. Tighten to 5 to 10 ft. lb. of torque. See Figure 3.3.

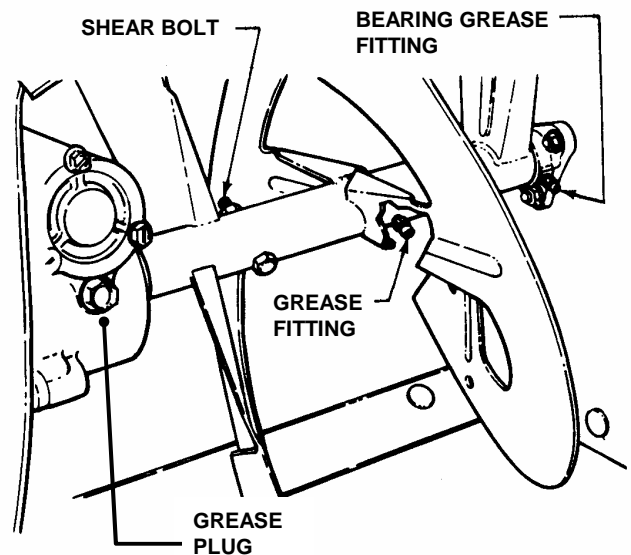

FIGURE 3.3

3.3.2. GENERAL LUBRICATION

After each season of operation, spread a small amount of grease on: The axle shafts for easy wheel removal. The discharge chute and mounting flange retainers for smooth rotation.

Section 3 - MAINTENANCE

3.4 ANNUALLY (END OF EACH SEASON)

Perform all maintenance as described in the maintenance schedule.

3.4.1. Engine

Refer to engine owner's manual for service instructions.

3.4.2. Spark Plug

Refer to engine owner's manual for service instructions.

3.5 STORAGE PROCEDURE

Refer to the Engine Owner's Manual for directions regarding engine storage preparations. Prepare the snow thrower for "end of season" storage as follows:

1. Drain fuel from fuel tank and let engine run until all fuel is out of the carburetor.
2. **Disconnect and remove the spark plug wire away from spark plug before any other preparations are made!**
3. Tape all openings closed to prevent spraying water into exhaust or air intakes during washing.
4. Tilt snow thrower up on its wheels and thoroughly clean the underside of the auger/impeller.
5. Lubricate all exposed metal with a light coating of oil to prevent corrosion.
6. Store the machine in a shed or other dry area, protected from weather.

3.6 MAINTENANCE and SERVICE PARTS

| MAINTENANCE and SERVICE PARTS | |
|---|---------------|
| Auger Drive Belt (Briggs Engines) | 1-3937 |
| Auger Drive Belt (Tecumseh Engines) | 1-3939 |
| Wheel Drive Belt (Briggs Engines) | 1-3936 |
| Wheel Drive Belt (Tecumseh Engines) | 2-9101 |
| Scraper Blade (24" Width Auger) | 3-6122 |
| Scraper Blade (26" Width Auger) | 3-9770 |
| Scraper Blade (30" Width Auger) | 3-6006 |
| Rubber Drive Tire | 1-0765 |
| Shear Bolts - 5/16-18 x 1-7/8" | 9-1550 |
| Hex Nuts - 5/16-18 | 9-1298 |
| Parts Manual for Large Frame Snow Throwers - Series 6 Models: 8246, 9266, 9266E, 11306 | #06069 |

Section 4 - REPAIR & ADJUSTMENTS

WARNING

DO NOT attempt any adjustments, maintenance, service, or repairs, with engine running. **Stop auger. Stop engine. Remove key. Disconnect spark plug wire and secure wire away from spark plug.**

4.1 AUGER/IMPELLER and WHEEL DRIVE BELT ADJUSTMENT/REPLACEMENT

When operating machine release the auger/impeller clutch control. The auger/impeller should come to a complete stop in 5 seconds. If the auger/impeller does not come to a complete stop in the required time, check and adjust belt tension. Inspect belts frequently for signs of excessive wear. Observe drive belts for slippage due to wear when operating machine. If slippage does occur, adjust/replace as follows.

4.1.1. AUGER and WHEEL DRIVE CABLE ADJUSTMENT

1. Measure control cable extension from a relaxed position to full extended position. Move control lever against handle. Measure the overall length of the spring. The length of the cable spring should increase by 3/8" when the clutch control lever is depressed. See Figure 4.1.

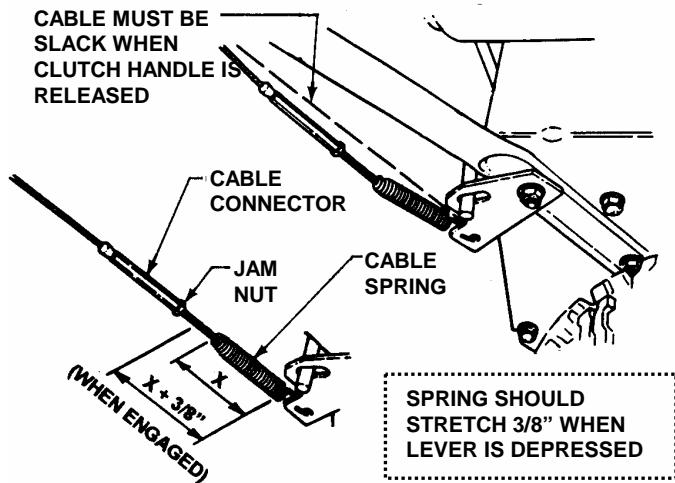

FIGURE 4.1

2. Adjust control cable by loosening jam nut at the upper end of cable. Hold threaded end of cable and then turn cable clockwise or counter clockwise until correct extension is achieved. Retighten jam nut.

IMPORTANT: DO NOT over tighten the control cables. The cables must have slack for the auger/impeller brake to function properly and for the wheel drive to de-clutch properly. If the auger control cannot be properly adjusted, belt adjustment and/or replacement will be required. Refer to Section "Auger Belt Idler Pulley Adjustment". If the wheel drive control cannot be properly adjusted, the rubber drive tire will require replacement. Refer to Section "Rubber Drive Tire Replacement".

4.1.2. AUGER BELT IDLER PULLEY ADJUSTMENT

NOTE: To adjust the idler pulley and properly tension the auger belt, the auger control cable adjustment must first be loosened as described in the following step. Cable adjustment must be checked after completing the idler pulley adjustment.

1. Loosen jam nut at the end of cable. Hold threaded end of cable and then turn metal housing of cable counter clockwise until threaded portion of cable is extracted from metal housing. Reinstall 1/2" of the threaded portion of cable back into metal housing. Retighten jam nut.
2. Remove belt cover. See Figure 4.2.

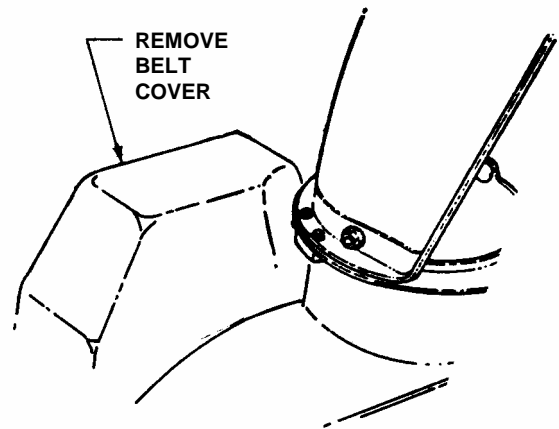

FIGURE 4.2

3. Loosen nut and bolt that secures the idler pulley. Move idler toward belt for more tension or away from belt for less tension. See Figure 4.3. Retighten bolt and nut securely.

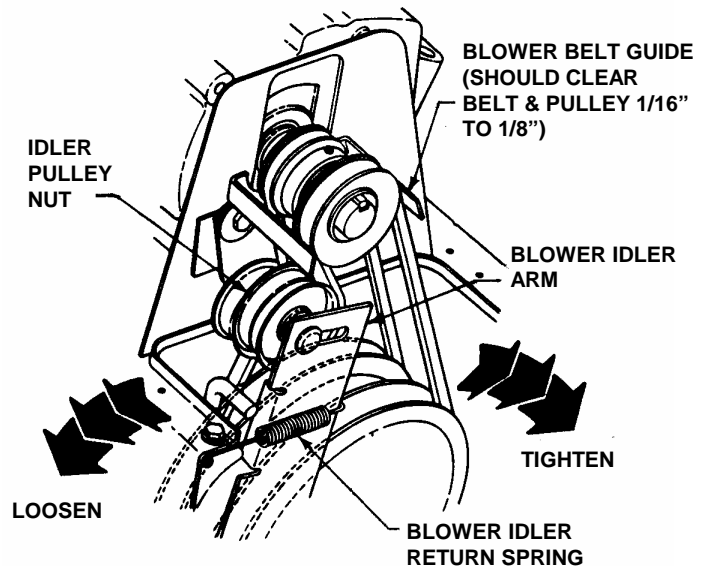

FIGURE 4.3

Section 4 - REPAIR & ADJUSTMENTS

WARNING

DO NOT attempt any adjustments, maintenance, service, or repairs, with engine running. Stop auger. Stop engine. Remove key. Disconnect spark plug wire and secure wire away from spark plug. Before tilting machine, drain all the fuel from fuel tank. Allow engine to run, outdoors where fumes can be safely dissipated, until all fuel is removed from carburetor.

4.1.2. AUGER DRIVE BELT ADJUSTMENT (IDLER PULLEY ADJUSTMENT) (Continued From Previous Page)

4. Recheck cable for proper extension (3/8").
5. Reinstall belt cover.

4.1.3. AUGER DRIVE BELT REPLACEMENT

Inspect belt frequently for signs of excessive wear. Visually check engine drive belt for cracking, fraying, severed or exposed belt strands.

1. Remove belt cover. See Figure 4.2.
2. Remove discharge chute.
3. Unhook both idler springs.
4. Loosen auger/impeller belt guide. See Figure 4.4.

IMPORTANT: Wheel drive belt will have to be removed from around engine drive pulley and engine shaft to install auger drive belt.

5. Remove auger drive belt from around engine pulley. See Figure 4.4.

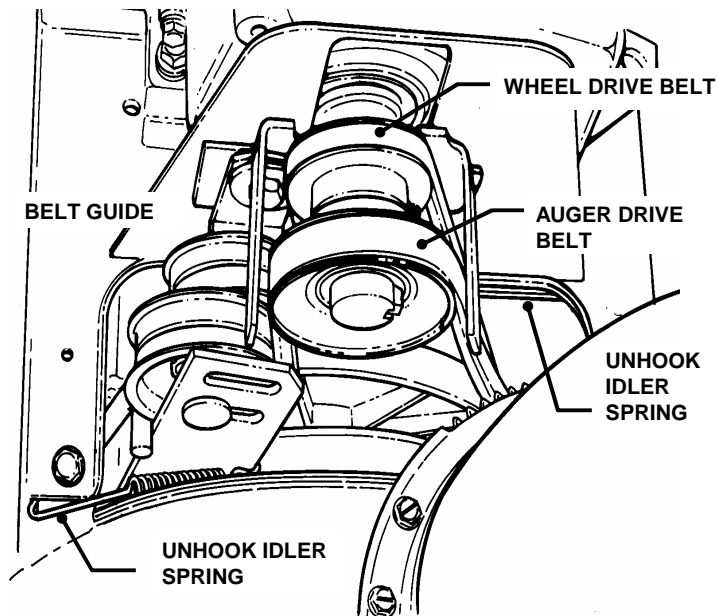

FIGURE 4.4

6. Tilt machine forward to gain access to drive system area. Secure machine in the tilted position to prevent tipping over. Remove drive system cover plate. See Figure 4.5.

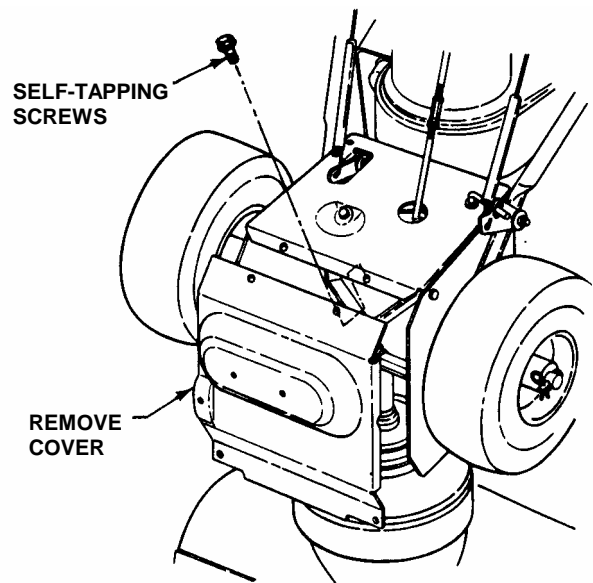

FIGURE 4.5

7. Remove auger drive belt from drive disc pulley. Route auger belt through drive system in between rubber drive tire and drive disc.
8. Route new auger drive belt through drive system. **NOTE:** New belt has to be routed in between rubber drive tire and drive disc to position it around auger pulley.
9. Reinstall wheel drive belt onto engine wheel drive pulley. Make sure belt is also positioned in the drive disc pulley groove.
10. Route auger drive belt around engine auger drive pulley. Make sure belt is also positioned in the drive disc pulley groove.
11. Position belt guide against auger drive belt and tighten securely.
12. Reinstall both idler springs.
13. Reinstall discharge chute, belt cover and drive system cover. Tighten screws securely.
14. Adjust idler for proper belt tension and control cable for proper spring extension. Refer to Section "Auger Belt Idler Pulley Adjustment".

Section 4 - REPAIR & ADJUSTMENTS

WARNING

DO NOT attempt any adjustments, maintenance, service, or repairs, with engine running. Stop auger. Stop engine. Remove key. Disconnect spark plug wire and secure wire away from spark plug. Before tilting machine, drain all the fuel from fuel tank. Allow engine to run, outdoors where fumes can be safely dissipated, until all fuel is removed from carburetor.

4.1.4. WHEEL DRIVE BELT REPLACEMENT

Inspect belt frequently for signs of excessive wear. Visually check engine drive belt for cracking, fraying, severed or exposed belt strands.

1. Remove belt cover. See Figure 4.2.
2. Remove discharge chute.
3. Unhook both idler springs.
4. Loosen auger/impeller belt guide. See Figure 4.6.

IMPORTANT: Auger drive belt will have to be removed from around engine drive pulley and engine shaft to install wheel drive belt.

5. Remove wheel drive belt from around engine pulley. See Figure 4.6.

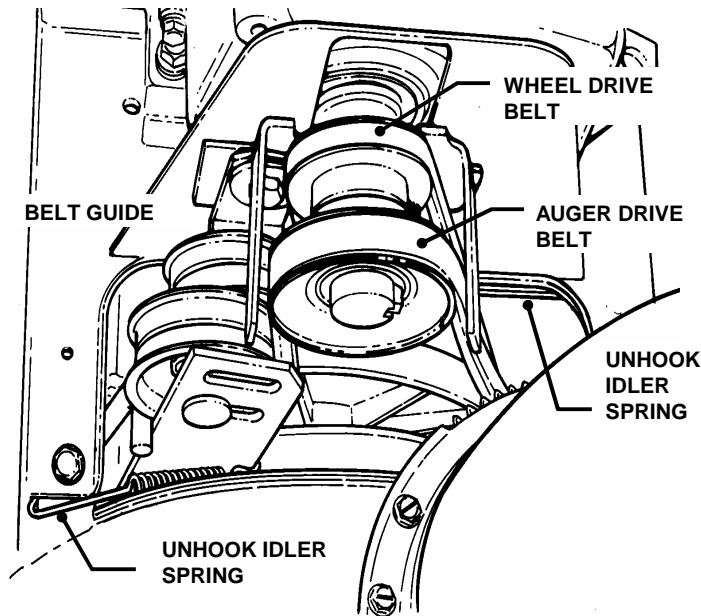

FIGURE 4.6

6. Tilt machine forward to gain access to drive system area. Secure machine in the tilted position to prevent tipping over. Remove drive system cover plate. See Figure 4.7.

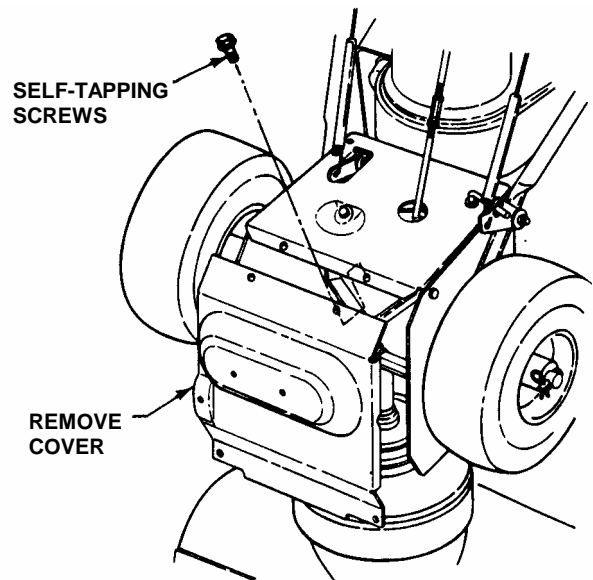

FIGURE 4.7

7. Remove wheel drive belt from drive disc pulley. Route wheel belt through drive system in between rubber drive tire and drive disc.
8. Route new wheel drive belt through drive system. **NOTE:** New belt has to be routed in between rubber drive tire and drive disc to position it around auger pulley.
9. Route wheel drive belt onto engine wheel drive pulley. Make sure belt is also positioned in the drive disc pulley groove.
10. Reinstall auger drive belt around engine auger drive pulley. Make sure belt is also positioned in the drive disc pulley groove.
11. Position belt guide against auger drive belt and tighten securely.
12. Reinstall both idler springs.
13. Reinstall discharge chute, belt cover and drive system cover. Tighten screws securely.

Section 4 - REPAIR & ADJUSTMENTS

4.1.5. SKID SHOE ADJUSTMENT

NOTE: It is recommended to raise the auger/impeller housing when clearing rough or graveled surfaces. To raise auger/impeller the skid shoes should be lowered.

1. Tilt machine up and place a wooden block under auger/impeller housing.
2. Loosen bolts on both skid shoes. Move shoes down to raise auger/impeller housing or move skid shoes up to lower auger/impeller housing. See Figure 4.8.

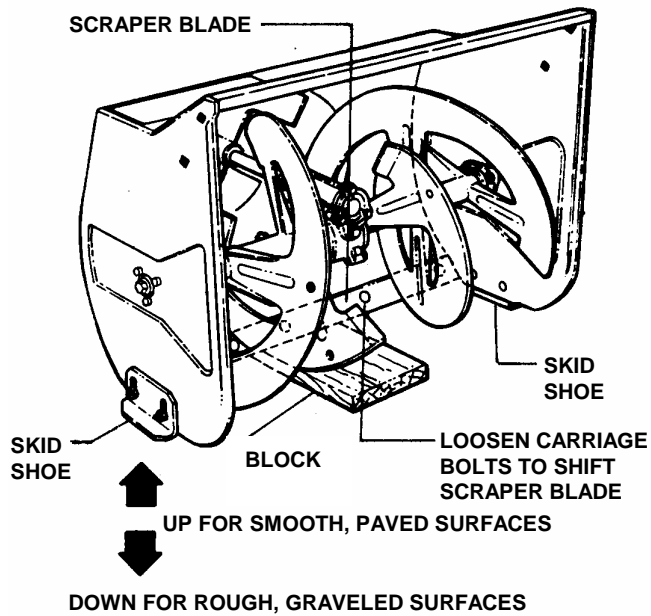

FIGURE 4.8

Section 4 - REPAIR & ADJUSTMENTS

4.1.6. SINGLE HANDLE CONTROL ADJUSTMENT

IMPORTANT: Standing in the operator's position, the left handle bar lever is for wheel drive engagement and disengagement. The right handle bar lever is for auger/impeller engagement and disengagement. Hold both levers down to handle bar for engagement and release levers for disengagement. When both levers are pressed down to the handle bar at the same time, the operator can release the right hand lever and the right lever will remain engaged as long as the left hand lever is held down to handle bar. Release the left hand lever and both levers will disengage.

1. Hold the wheel drive control lever down against the handle. See Figure 4.9.

2. Check position of the cam lock. It must align with the adjusting line located on the cam lock bracket.

3. To adjust, loosen the nuts on the cable guide support bracket and move the bracket in or out until the cam lock aligns with the adjusting line. Retighten nuts.

4. Hold the wheel drive control lever down to the handle bar, at the same time press the auger/impeller control lever down to the handle bar and hold in position.

5. Check the position of the cable ferrule in relation to the cam lock. The ferrule must be located $1/16"$ (.060) above the hook of the cam lock. To adjust, loosen the three nuts that secure the cam lock bracket. Slide bracket up or down until correct measurement is achieved. Retighten nuts securely. See Figure 4.9.

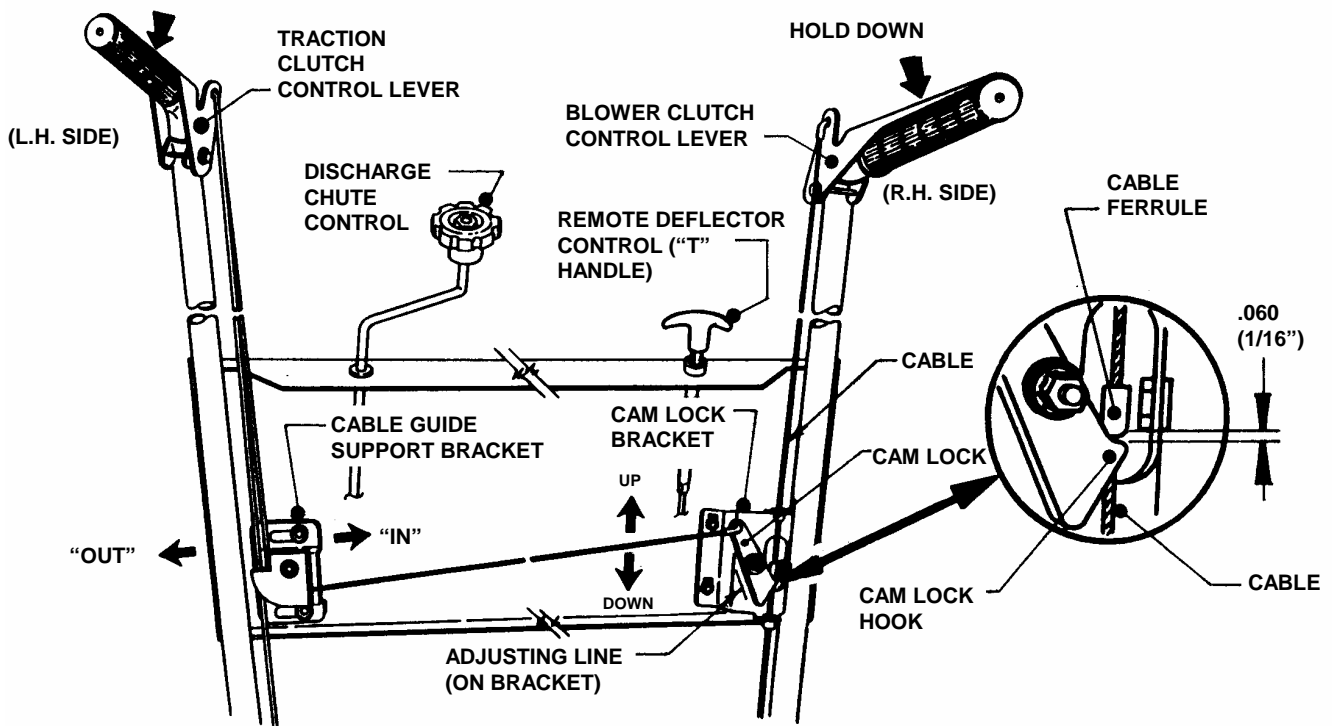

FIGURE 4.9

Section 4 - REPAIR & ADJUSTMENTS

4.1.7. AUGER SHEAR BOLT REPLACEMENT

IMPORTANT: If engine is operating correctly and auger/impeller drive belt is not damaged or severed, but the auger/impeller does not rotate it is possibly the auger/impeller shaft shear bolt.

1. Remove shear bolt and nut from auger. Discard old shear bolt and nut. **DO NOT** reuse bolt or nut under any circumstances. Always replace existing hardware with genuine Snapper new replacement shear bolts and nuts. **DO NOT** substitute these shear bolts and nuts as auger/impeller and engine damage can result.
2. Install new shear bolts and nuts. Tighten to 5 to 10 ft. lb. of torque. See Figure 4.10.

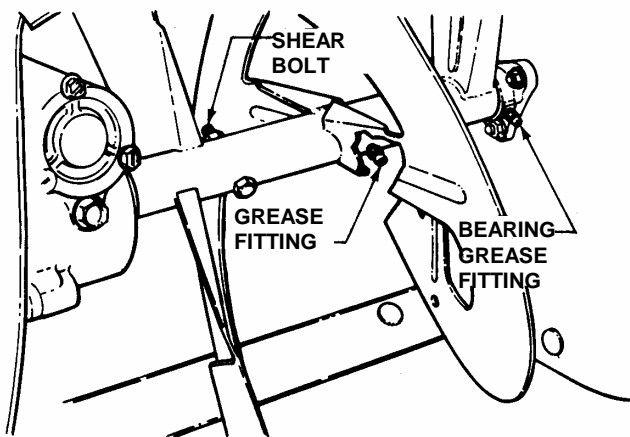

FIGURE 4.10

4.1.8. CHUTE CRANK ADJUSTMENT

1. Loosen adjustment bolt. Move crank worm bracket away from ring gear slightly. **NOTE:** The worm gear should always maintain full contact with ring gear after adjustment. Retighten adjustment bolt. If crank still does not operate satisfactorily, lubricate worm gear and ring gear with grease. See Figure 4.11.

4.1.9. RUBBER DRIVE TIRE REPLACEMENT

1. Tilt machine forward to gain access to drive system area. Secure machine in the tilted position to prevent tipping over. Remove drive system cover plate. See Figure 4.5.
2. Remove the three nuts that secure rubber drive tire to the chain case. Remove drive tire. See Figure 4.12.
3. Install new rubber drive tire. Reinstall the three nuts. Torque to 15 to 25 ft. lbs. See Figure 4.12.

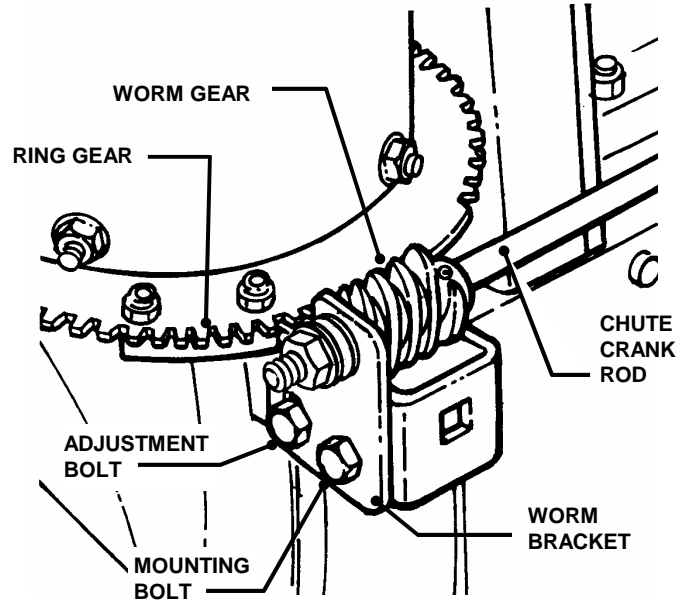

FIGURE 4.11

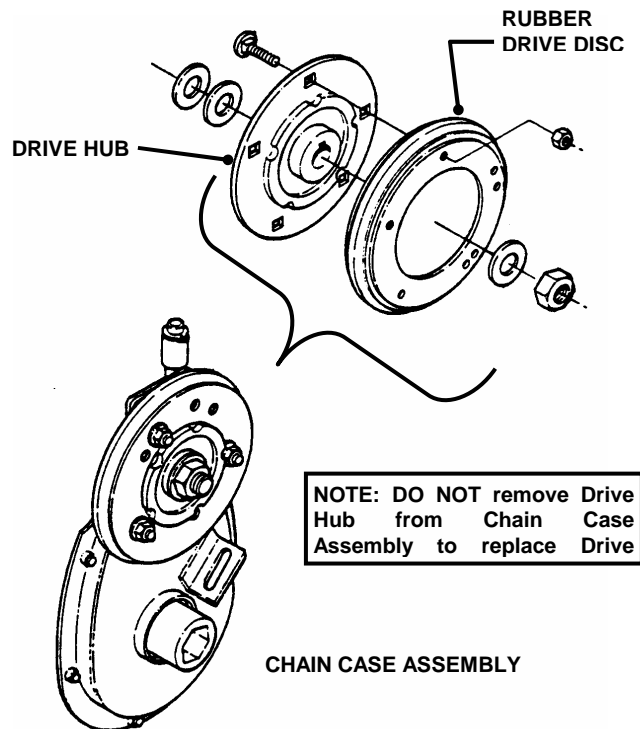

FIGURE 4.12

TROUBLESHOOTING

| PROBLEM | PROBABLE CAUSE | CORRECTIVE ACTION |
|---|--|---|
| Engine Will Not Start Using Recoil Starter | 1. Fuel tank empty. | 1. Fill fuel tank with fresh fuel/oil mix. |
| | 2. Engine needs choking and priming. | 2. Move choke control to "CHOKE" position. Push primer bulb three times. |
| | 3. Spark plug wire disconnected. | 3. Place spark plug wire onto spark plug. |
| | 4. Fuel shut off valve closed. | 4. Move fuel shut off valve to the on position. |
| Engine Will Not Start Using Electric Starter | 1. Power extension cord not plugged into machine or 120 Volt outlet for U.S.A. or 230 Volt for Europe. | 1. Plug power extension cord into machine & into 120 Volt outlet for U.S.A. or 230 Volt for Europe. |
| | 2. Power extension cord damaged. | 2. Discard damaged power extension cord. |
| | 3. Starter switch damaged or faulty. | 3. Replace starter switch. |
| Engine Stalls or Stops After Running | 1. Water, debris or stale fuel in fuel system. | 1. Drain and clean fuel system. |
| | 2. Choke control in the "CHOKE" position. | 2. Move choke control to "OFF" position. |
| | 3. Fuel tank empty. | 3. Fill with fuel to proper level. |
| | 4. Air intake clogged with snow or debris. | 4. Unclog air intake. |
| | 5. Spark plug defective or gap set improperly. | 5. Service spark plug. |
| Engine Loses Power | 1. Engine lubrication oil level is low. | 1. Add oil to the engine to full level. |
| | 2. Spark plug faulty. | 2. Service spark plug. |
| | 3. Water, debris or stale fuel in fuel system. | 3. Drain and clean fuel system. |
| Excessive Vibration | 1. Damaged, out of balance or bent auger. | 1. Service auger. |
| | 2. Loose engine or auger/impeller components. | 2. Service and tighten loose components. |
| | 3. Bent or loose Idler pulley. | 3. Tighten or replace pulley. |
| | 4. Cracked, severed or frayed belt. | 4. Replace belt. |
| Poor Snow Discharging | 1. Clogged discharge chute. | 1. Stop engine and unclog discharge chute. |
| | 2. Damaged or bent auger/impeller or components. | 2. Service auger/impeller or components. |
| | 3. Cracked, severed or frayed belt. | 3. Replace belt. |
| | 4. Belt tension out of adjustment. | 4. Adjust belt tension. |
| | 5. Insufficient lubrication in auger bearings. | 5. Lubricate all bearings as specified in manuals. |

SERVICE SCHEDULE

| ITEM | SERVICE PERFORMED | REF. | EACH USE | 5 HRS | 25 HRS | 50 HRS | 100 HRS | EACH SEASON |
|------------------------------|--|----------------|----------|-------|--------|--------|---------|-------------|
| Spark Plug | Replace | Engine Manual | | | | | X | |
| Engine Oil | Check Oil Level | Engine Manual | X | | | | | |
| | Initial Oil Change | Engine Manual | | X | | | | |
| | Periodic Oil Change | Engine Manual | | | X | | | |
| Air Filter | Clean or Replace | Engine Manual | | | | | | |
| Engine Cooling System | Clean Shroud & Fins | Engine Manual | | | | | X | |
| Drive Belts | Check For Wear, Tension and Adjustments | Page 11, 13-15 | | | X | X | | X |
| Auger & Impeller | Check For Damage, Lubrication, Stop Time | Page 11 | X | | | | | X |
| Tires | Check Air Pressure | Page 6 | X | | | | | |

SNAPPER®

2 YEAR LIMITED WARRANTY

For two (2) years from purchase date for the original purchaser's residential, non-commercial use, **SNAPPER**, through any authorized **SNAPPER** dealer will replace, free of charge (except for taxes where applicable), any part or parts found upon examination by the factory at McDonough, Georgia, to be defective in material or workmanship or both.

For ninety (90) days from purchase date for the original purchaser's commercial, rental, or other non-residential use, **SNAPPER**, through any authorized **SNAPPER** dealer will replace, free of charge, any part or parts found upon examination by the factory at McDonough, Georgia, to be defective in material or workmanship or both.

All transportation costs incurred by the purchaser in submitting material to an authorized **SNAPPER** dealer for replacement under this warranty must be paid by the purchaser.

This warranty does not apply to certain transmissions, to engines and their components, and batteries, as these items are warranted separately. This warranty does not apply to parts that have been damaged by accident, alteration, abuse, improper lubrication, normal wear, or other cause beyond the control of **SNAPPER**. This warranty does not cover any machine or component part that has been altered or modified changing safety, performance, or durability.

Batteries have a one (1) year warranty period with free replacement if required for one (1) year from the original purchase date. **SNAPPER** will not be responsible for any installation cost incurred. The battery warranty only covers original equipment batteries and does not cover damage to the battery or machine caused by neglect or abuse, destruction by fire, explosion, freezing, overcharging, improper maintenance, or use of improper electrolyte.

There is no other express warranty.

DISCLAIMER OF WARRANTY

Implied warranties, including those of merchantability and fitness for a particular purpose, are limited to two (2) years from purchase date for the original purchaser's residential or other non-commercial use, and ninety (90) days from purchase for the original purchaser's commercial, rental or other non-residential use, and to the extent permitted by law, any and all implied warranties are excluded. This is the exclusive remedy. Liabilities for consequential damages, under any and all warranties are excluded.

Some states do not allow limitations on how long an implied warranty lasts, or do not allow the exclusion or limitation of incidental or consequential damages, so the above limitation or exclusion may not apply to you.

This warranty gives you specific legal rights, and you may also have other rights which vary from state to state.

WARNING: THE USE OF REPLACEMENT PARTS OTHER THAN GENUINE SNAPPER PARTS MAY IMPAIR THE SAFETY OF SNAPPER PRODUCTS AND WILL VOID ANY LIABILITY AND WARRANTY BY SNAPPER ASSOCIATED WITH THE USE OF SUCH PARTS.

IMPORTANT: Please fill out the attached **SNAPPER** Product Registration Card immediately and mail to:
Snapper's Product Registration Center, P.O. Box 1379, McDonough, Georgia 30253

SNAPPER PRODUCT REGISTRATION FORM

**IMPORTANT: KEEP THIS INFORMATION FOR YOUR PERSONAL RECORDS
(Complete the following information on your Snapper purchase)**

Model Number _____

Serial Number _____

Date of Purchase _____

Retailer _____

Retailer's Phone Number _____

It is very important that you register your purchase with Snapper to ensure warranty coverage. Please mail your product registration card to:

Snapper at P.O. Box 1379, McDonough, Georgia 30253.

Or you may register on line at www.snapper.com.

You can contact us at our web site or if you would like to speak with a Customer Service Representative. Call us at the Snapper Customer Relations Center. For faster service please have your Serial Number and Model Number available.

Call the Snapper Customer Relations Center at 1-800-935-2967.

Eastern Standard Time

Monday through Friday from 8am to 6pm.

Saturday from 9am to 1pm.

Safety Instructions & Operator's Manual for

SNAPPER®

TWO STAGE LARGE FRAME SNOW THROWER SERIES 6

IMPORTANT

Snapper products are built using engines that meet or exceed all applicable emissions requirements on the date manufactured. The labels on those engines contain very important emissions information and critical safety warnings. Read, Understand, and Follow all warnings and instructions in this manual, the engine manual, and on the machine, engine and attachments. If you have any questions about your Snapper product, contact your local authorized Snapper dealer or contact Snapper Customer Service at Snapper, McDonough, GA. 30253. Phone: (1-800-935-2967).



WARNING

BATTERY POSTS, TERMINALS AND RELATED ACCESSORIES CONTAIN LEAD AND LEAD COMPOUNDS, CHEMICALS KNOWN TO THE STATE OF CALIFORNIA TO CAUSE CANCER AND BIRTH DEFECTS OR OTHER REPRODUCTIVE HARM. WASH HANDS AFTER HANDLING.



WARNING

ENGINE EXHAUST, SOME OF ITS CONSTITUENTS, AND CERTAIN VEHICLE COMPONENTS CONTAIN OR EMIT CHEMICALS KNOWN TO THE STATE OF CALIFORNIA TO CAUSE CANCER OR OTHER REPRODUCTIVE HARM.

SNAPPER® McDonough, GA., 30253 U.S.A.

COPYRIGHT © 2003
SNAPPER PRODUCTS INC.
ALL RIGHTS RESERVED

INSTRUCTION No. 7-5394 (I.R. 3/3/03)