

Safety Instruction & Operator's Manual for

SNAPPER[®]

2-STAGE **LARGE**
FRAME

SNOW THROWERS

MODELS

824

826

1030

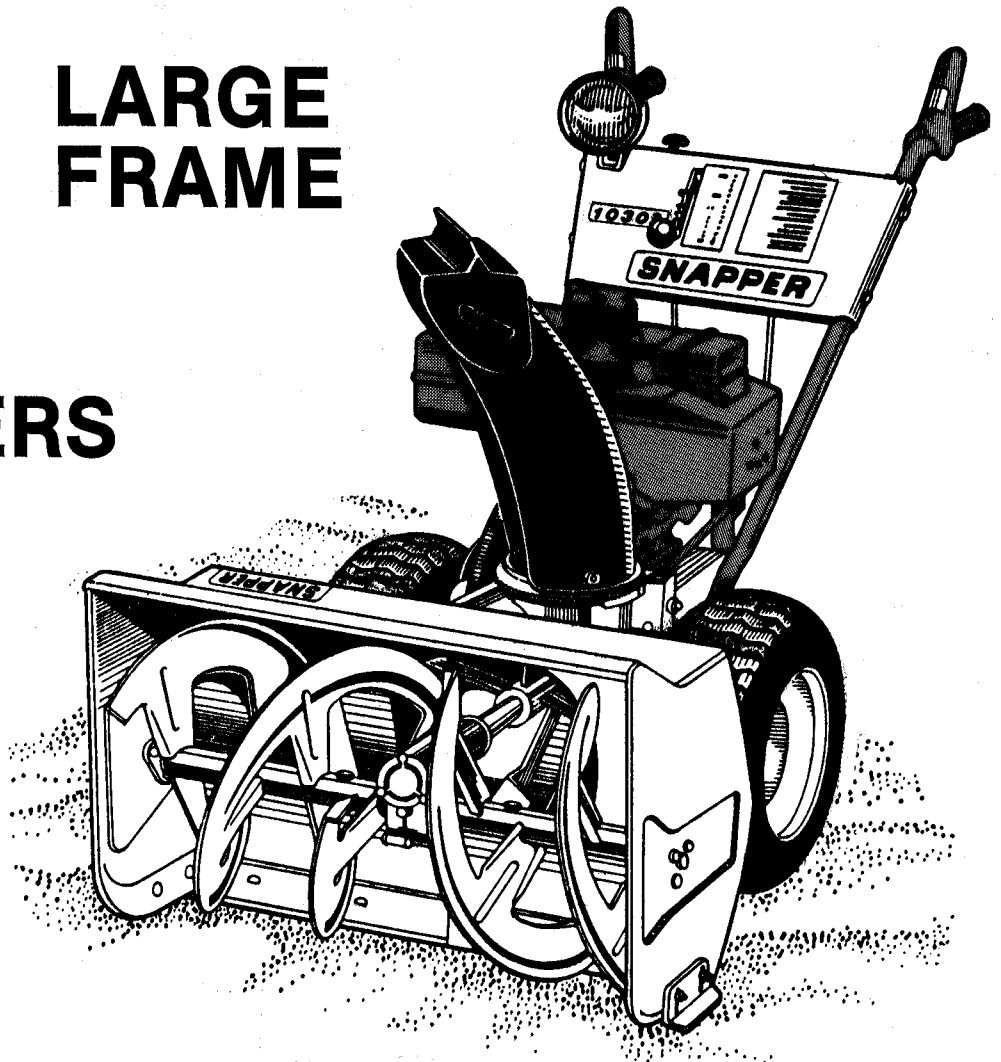

MODEL 1030 SHOWN

THANK YOU for buying a **SNAPPER** product! Your **SNAPPER SNOW THROWER** was designed and built to provide long and satisfactory service. Keep in mind that it, like any other mechanical device, can be potentially dangerous if used improperly and that no accident prevention program can be successful without the wholehearted cooperation of the person responsible for the operation of the equipment. Study this Operator's Manual carefully to learn about the operation of all controls and pay particular attention to the **IMPORTANT SAFETY PRECAUTIONS** on Page 2. Following these instructions will help you continue to enjoy the trouble-free operation expected of a **SNAPPER** product.

SNAPPER® McDonough, GA., 30253 U.S.A.

MANUAL #1-9366 (REV. 3, 11/93)



SAFETY INSTRUCTIONS



WARNING: This powerful snow thrower is capable of amputating hands and feet and of throwing objects causing injury. Read this manual carefully and question your Snapper Dealer if something is not clear. Should the dealer be unable to answer to your satisfaction, send a letter to the Snapper Customer Service Department at Snapper, Post Office Box 777, McDonough, Georgia 30253, or Phone: (404)954-2500.

PROTECTION FOR CHILDREN

1. DO NOT allow children in area when Snow Thrower is being operated.
2. DO NOT allow pre-teen children to operate Snow Thrower.
3. DO NOT allow irresponsible teenagers to operate the machine — allow teenager only if exhibiting mature judgement and then only after thorough instruction and under close supervision of an experienced operator.

PREPARATION

1. Read this manual, get to know where all controls are located and practice how to use them before starting for the first time and at the beginning of each season. Pay attention to Decals on engine and snow thrower.
2. Wear protective clothing including face mask and boots which will give you maximum footing on slippery surfaces.
3. Before the first snow fall, check the area to be cleared and remove all objects such as doormats, sticks, toys, wires, rocks, etc., which could be hurled or jam the snow thrower.
4. Survey the area to be cleared beforehand and plan where snow is to be blown. Be prepared to release blower clutch or to change deflector quickly to discharge away from windows, cars, buildings and doorways to avoid property damage or personal injury from hurled objects.
5. Adjust the collector housing height by adjusting skid shoes to clear rough spots or gravelled surfaces before starting.
6. Handle fuel with care. Store only in approved gasoline container. Move machine outdoors where fumes can be safely dissipated before filling tank. Never add fuel when engine is running. Allow cooling off period after stopping to avoid spilled fuel from igniting on contact with hot engine parts.

OPERATIONAL PRECAUTIONS

1. Before starting, make visual check to make sure Auger and Impeller housings are clear and all guards and shields are in place and tight.
2. Warn everyone in advance to stay clear of area but keep especially watchful for children and pets darting into area while operating.
3. Start engine only when exhaust fumes can be dissipated, allow brief warm-up period, practice operation of controls outside before putting the machine to work.
4. Start in slow speed and adjust traction speed to insure safe footing as you walk behind the unit. Exercise extreme caution to retain footing when reversing direction.
5. Transport unit with blower clutch handle released and activate only when snow is to be cleared. Set deflector to discharge desired distance beforehand.
6. Adjust traction speed slow enough to avoid overloading capacity and resulting in clogging of the Auger/Impeller housing.
7. Should the blower become clogged, release traction and blower clutch handles and stop the engine; as an additional precaution, disconnect the spark plug wire before attempting to unclog the collector and impeller.
8. If you strike a hard object and break the auger shear pin, stop the engine and as an additional precaution, disconnect the spark plug wire before inspecting for damage, and/or replacing the shear pin.
9. Stop the engine if unit starts to vibrate excessively as this normally indicates mechanical problems. As an additional precaution, disconnect the spark plug wire before servicing or repairing the machine.
10. Avoid clearing steep slopes and keep away from drop-off areas where footing is doubtful or where the machine could tip over. Clear snow across the face of slopes whenever possible.
11. Stop the engine and remove the key whenever you leave the unit unattended to eliminate the possibility of children or untrained adults attempting to operate the machine.

INTRODUCTION

This manual covers the recommended operating instructions and routine service requirements for Snapper two-stage snow throwers. On units with four digit model numbers, the first digit indicates engine horsepower and the next two digits indicate approximate blower housing width. With the five digit mode, the first two digits indicate horsepower and next two, blower housing width. The last digit is reserved for major model change. Differences between models are pointed out wherever pertinent in the manual.

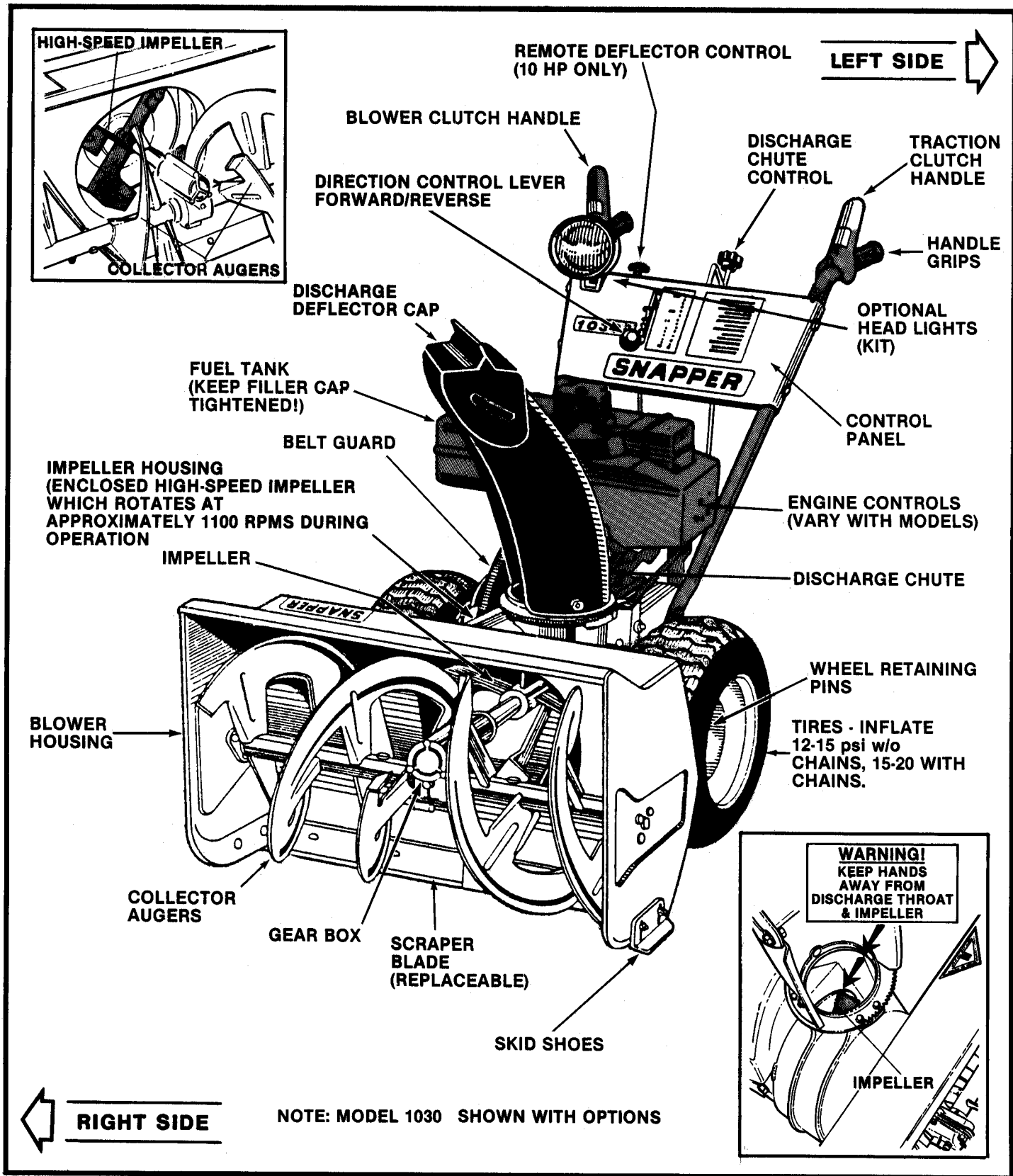

FIGURE 1 - LOCATION OF CONTROLS & OTHER FEATURES

OPERATING INSTRUCTIONS

Make sure that each person you authorize to operate your Snow Thrower reads this manual beforehand and pays particular attention to the safety precautions on the inside front cover and to the warning decals on the machine. Check and perform the following before each start-up.

PRE-START CHECK & ADJUSTMENTS

- **ENGINE LUBE:** Check level and add oil, if needed, of weight and grade specified in the Engine Owner's Manual.
- **FUEL SUPPLY:** After making sure unit is safely away from ignition producing appliances and in area where gasoline fumes can be dissipated, fill fuel tank with gasoline specified in Engine Manual.
- **CHECK TIRES** and bring pressure up to specifications - 12-15 psi without tire chains or 15-20 psi with chains.
- **CHECK UNIT** to make sure guards and shields are in place and tight. Also check blower housing to insure that it is clear of any debris.
- **RESET SKID SHOES** to suit area to be cleared. Lower skid shoes to provide greater clearance over gravel or raise the shoes for smooth, paved surface. Refer to FIG. 8 skid shoe adjustment for details.
- **SET DEFLECTOR CAP** to throw snow desired distance. Loosen wing nut, push cap edge back even with the chute to throw snow up to 30 feet away or pull cap all the way out to throw snow only about three feet. Retighten the wing nut after repositioning cap. Always stop engine before repositioning Cap or Remote Deflector Control.

OPERATIONAL CONTROLS

Know how to stop the Snow Thrower quickly in preparation for possible emergency situations. Forward or reverse motion is stopped by releasing your grip on the **TRACTION CLUTCH** handle on the left handle bar. The collector augers blades and impeller fan will stop rotating within five seconds* after releasing the **BLOWER CLUTCH** handle on the right. Stop the engines on all models by removing the ignition key. Other operational controls are discussed where pertinent under the following operating procedures.

*NOTE: If rotation continues after five seconds, refer to the **CLUTCH CABLE, BELT SERVICE** instructions for readjustment.

SINGLE CONTROL FEATURE: If you continue holding the **TRACTION CLUTCH** handle down while blowing snow, you can release the **BLOWER CLUTCH** handle without stopping the blower. This feature frees your right hand to turn the chute crank to discharge snow in a new direction. Releasing the **TRACTION CLUTCH** handle stops motion and the blower.

STARTING & WARM-UP

Whenever possible, push Snow Thrower outdoors before starting. If the unit must be started inside your garage, for example, make sure doors are wide open to provide maximum ventilation. Move the unit outdoors as soon as possible after starting. After performing the pre-start checks and services described earlier, proceed as follows:

1. **THROTTLE CONTROL:** Move control to **FAST** position.
2. **CHOKE:** Refer to Engine Manual for priming and/or choking details.
3. **ENGINE IGNITION:** On all units, insert key or turn key to **ON** position.

4(A) ROPE STARTING: On manual start models, pull starting rope out in smooth, steady motion until engine starts. To prolong the life of the starter rope, slowly guide the handle back to the engine rather than allowing it to snap back.

4(B) ELECTRIC STARTING: On units with plug-in 120 Volt electric start, connect the starter cable to the engine starter system then insert the three pronged plug into a grounded 110-volt power receptacle and depress the starter button on the cable until engine starts. Detach cable from receptacle and engine. On jump start equipped models, refer to instructions provided in kit.

NOTE: If engine does not start after five seconds of continuous cranking, release electric start button to prevent overheating of the starting motor. Locate and correct cause of starting problem before repeating electric starting attempt.

WARM-UP PERIOD: Allow brief warm-up outside with clutches released to avoid stalling cold engine. Reset Choke as instructed in Engine Manual as the unit warms up.

OPERATION: Select desired traction speed by adjusting **DIRECTION CONTROL LEVER**, depress **TRACTION CLUTCH** handle and drive unit to area to be cleared then depress **BLOWER CLUTCH** handle and proceed to blow snow. The **THROTTLE CONTROL** should normally be in the **FAST** position for best result under most conditions. **CAUTION:** If clogging occurs, back unit away from snow bank, release both **CLUTCH** handles and, as a further precaution, stop the engine and remove spark plug wire before clearing the snow from the housing and/or discharge chute.

BEFORE STOPPING: Move unit to cleared area, release **TRACTION CLUTCH** handle and run up to top speed with **BLOWER CLUTCH HANDLE** depressed to clear housing of slush and snow thus preventing freeze-up of the impeller upon restarting next time.

STOPPING PROCEDURE: On all units, remove the key to stop engine or move the **THROTTLE CONTROL** to **OFF** or **STOP**.

SERVICE PROCEDURE

LUBRICATION SERVICES

Refer to the Engine Manual for lubrication requirements on the engine powering your Snow Thrower. Your Snow Thrower unit has six grease fittings, four on the collector augers and two on the auger shaft bearings as shown in Fig. 2. The unit also has a lube checkpoint at the front of the gearbox shown in FIG. 3. Service these and the other general lube points as follows:

AUGER LUBRICATION: ONCE EACH YEAR, preferably at the end of the winter season, remove the two shear bolts, apply grease to the fittings then spin the auger to work the grease out along the auger shaft. Continue greasing and spinning augers until grease appears at both ends of each auger tube. Reinstall shear bolts and nuts after servicing. This procedure will prevent the auger shaft from rusting to the auger tube. Refer to FIG. 2.

BEARING LUBE: ONCE EACH YEAR, apply one or two shots of grease from gun to the bearing grease fittings located at the ends of the auger shaft just inside the blower housings. Refer to FIG. 2.

GENERAL LUBE POINTS: ONCE EACH YEAR, or more often if rust formation hampers operation, spread a light coating of grease on the chute crank worm and on the underside of the gear ring at the base of the discharge chute. Also squirt oil from oil can into the gap between the inside of the discharge chute and the outside of the discharge flange of the blower housing. Crank chute back and forth while oiling to spread lubrication evenly over both surfaces. Although not absolutely necessary, you may want to remove each wheel at the end of the season and apply a coating of grease on the axle shafts to prevent rust and allow the wheels to be moved more easily from transport to traction mode during the next season.

GEARBOX LUBE: AFTER EACH 25 HOURS of operation (or each time the engine oil level is checked) remove the plug at the front of the gearbox and check the oil level. With the Thrower on a flat, level surface, the oil should be even with the lower edge of the check hole. Use an oil can containing the same weight and grade of oil specified for the engine crankcase to bring the level up to the point of overflowing from the hole. Reinstall the oil plug after servicing.

CHUTE CRANK SERVICE

If the chute does not crank easily after lubricating as specified under GENERAL LUBE SERVICES, loosen both nuts on the outside of the crank worm bracket as shown in FIG. 4 and move the bracket slightly away from the chute gear ring or back in toward the ring until the chute again cranks with minimum effort. Retighten inside nut first then jam the outside nut tight against the inside nut to lock at the new setting.

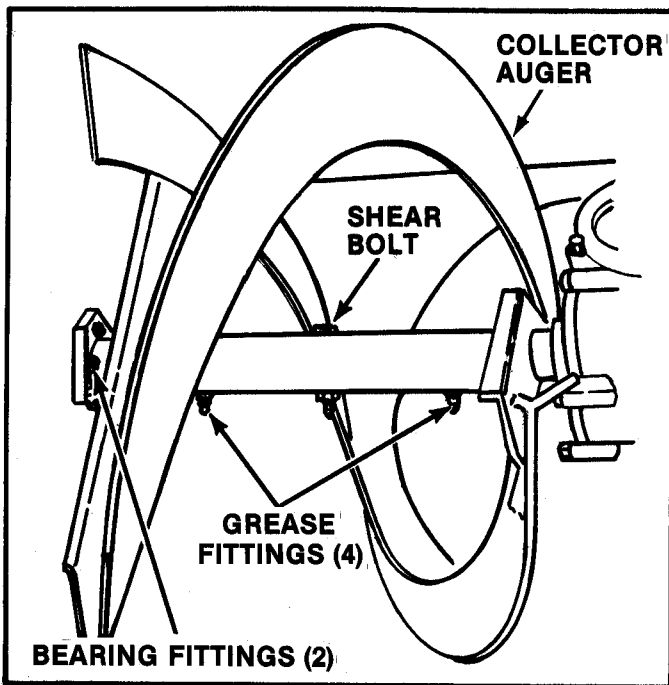

FIGURE 2 - GREASE FITTING LOCATIONS

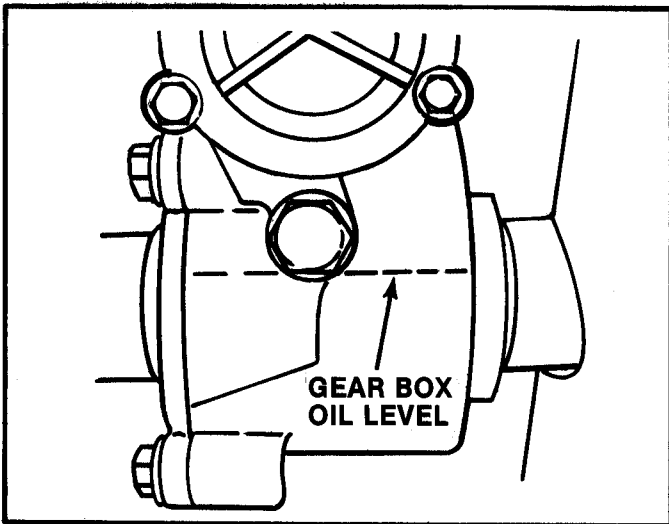

FIGURE 3 - GEAR BOX LUBRICATION

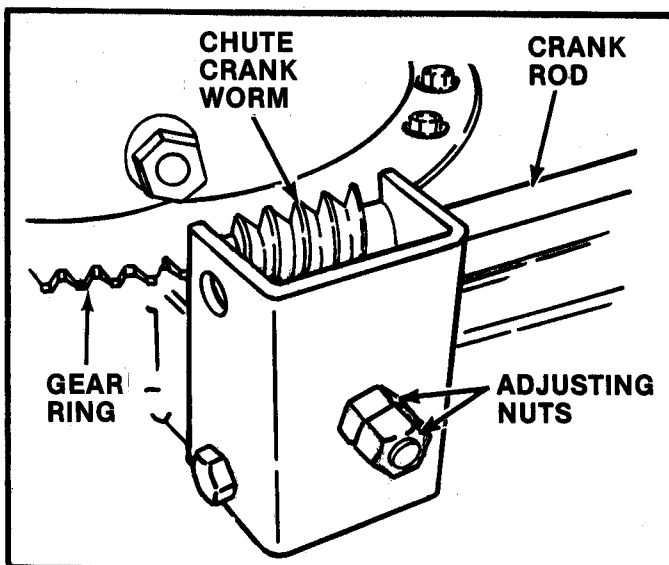

FIGURE 4 - CHUTE CRANK WORM GEAR

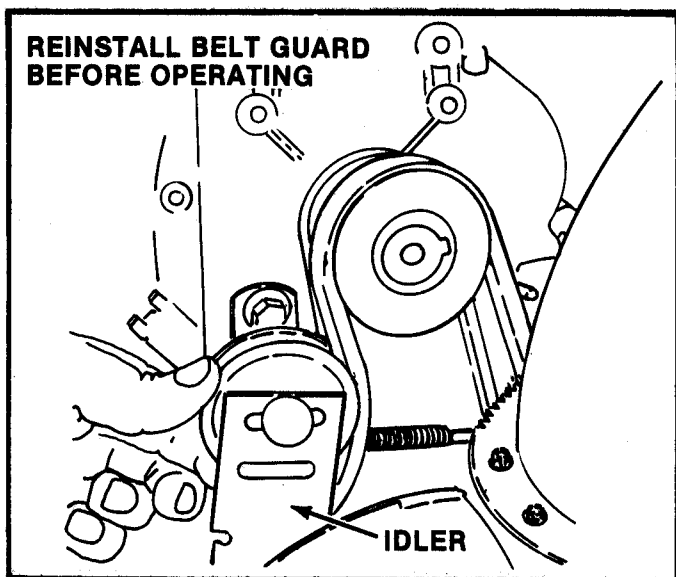

FIGURE 5 - BELT TENSION ADJUSTMENT

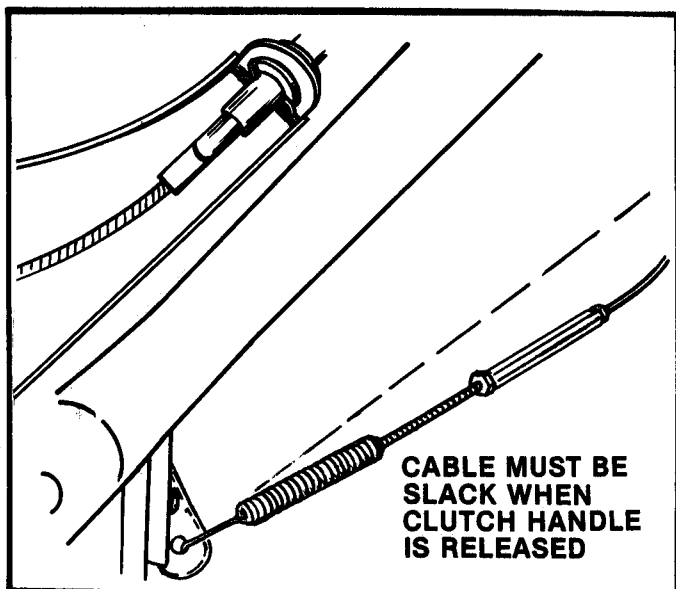

FIGURE 6 - CLUTCH CABLE SLACK

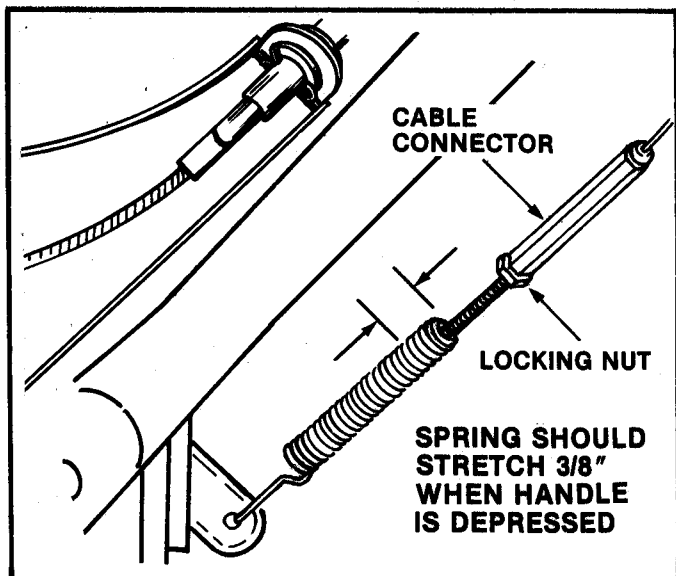

FIGURE 7 - CLUTCH CABLE TENSION

BELT SERVICE

Belts do not require attention at any specific interval but should be checked if performance deteriorates as this could be caused by slippage due to worn or loose belts. Check and adjust tension of clutch cables first as described in the CLUTCH ADJUSTMENT section then check the belts if poor performance continues after clutch cable tension has been corrected. Make sure the engine is stopped and the spark plug wire disconnected before working on the belts.

NOTE: Blower rotation should cease within five seconds after the clutch handle is released. If rotation continues after five seconds, cable may be too tight. If readjusting the cable does not correct the stopping time, check to make sure the idler return spring is connected and that the idler is properly set. See your Snapper Dealer to have this condition corrected.

BELT TENSION: Tension on the traction drive belt is automatically maintained by an individual idler spring. After removing the belt guard, check to make sure this spring is intact and properly hooked up to the frame and idler arm. If the spring is properly connected, check for excessively worn belts. Notice the return spring on the idler for the blower drive - this spring activates the brake. The idler should always return to braking position! Tension of the blower drive belt, which is on the outside groove of the engine drive pulley, is adjusted by loosening and repositioning the idler pulley--to increase tension, loosen the idler pulley retaining nut, hold the idler arm and push the pulley tighter against the belt. Retighten nut after repositioning and check for proper clutching action with blower clutch handle released. Tension of the traction belt on the inside groove is non-adjustable. Before reinstalling belt guard check to make sure the wire belt guide on the right side is about 1/16" away from the outside surface of the blower belt with clutch engaged. Bend the guide in or out to correct clearance.

CLUTCH CABLE ADJUSTMENT

If slippage is noted, check tension of both clutch cables. When properly adjusted, the cables should be completely slack with clutch handle released and tight when the handle is fully depressed. The springs on both cables should deflect 3/8" when the handle is depressed. To adjust, loosen nut on cable connector, turn connector to shorten or lengthen cable as needed to attain the 3/8" deflection, turn nut tight against connector tube to lock at correct setting (See FIG. 7).

SKID SHOE ADJUSTMENT

The skid shoes should be lowered to raise the blower housing to clear gravelled or rough surfaces, or adjust until almost even with the edges of the housing to allow clearing down to smooth paved surfaces. Note that the skid shoes can be installed upside down to track better over icy or hard-packed surfaces. To adjust the skid shoes, place a block under the lower edge of the blower housing, loosen the retaining nuts and slide shoe up or down to desired height then retighten the nuts. Set both skid shoes in the same position. Remove the block. See FIG. 8.

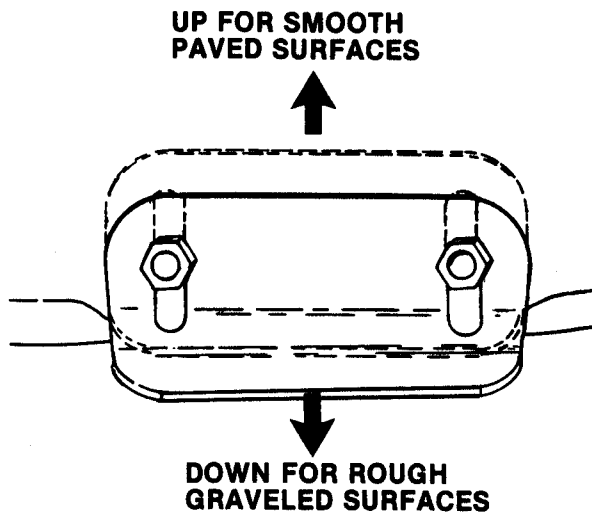

FIGURE 8 - SKID SHOE ADJUSTMENT

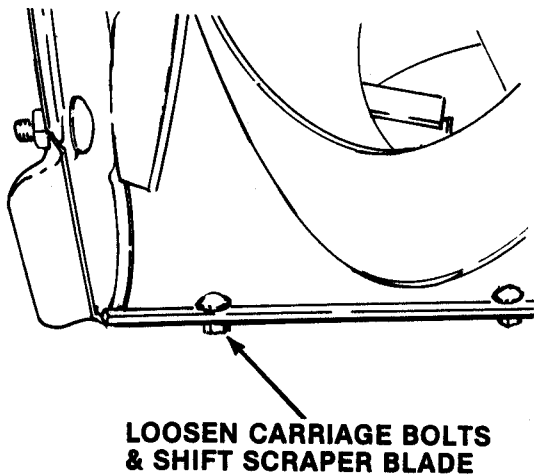

FIGURE 9 - SCRAPER BLADE ADJUSTMENT

SCRAPER BLADE

Your Snow Thrower is equipped with an adjustable scraper on the inside leading edge of the collector housing. Its purpose is to prevent wear and damage to the housing. When the scraper itself wears down close to the lower edge of the housing, loosen the five nuts on the backside of the housing and slide the scraper downward. Retighten the five nuts after repositioning. Replace the scraper if badly nicked or when it no longer can be adjusted below the edge of the housing.

CLUTCH CONTROL ADJUSTMENTS

If the clutch controls need readjusting, turn engine off. Disconnect spark plug wire! Refer to FIG. 10. Reset as follows:

(A) Have an assistant temporarily hold the traction clutch control down against the handle grip. The edge of the cam lock must be aligned with the adjustment line scribed on the cam lock bracket as shown. To align, loosen the two fasteners holding the cable guide support bracket and slide the bracket inward or outward as needed, then tighten the fasteners.

(B) With the traction clutch held down, have assistant hold the blower clutch control against handle. The ferrule (shown in the Inset of FIG. 10) must be located about 1/16" (.060" exact) above the hook of the cam lock. To adjust, loosen the 3 fasteners on the cam lock bracket and slide the bracket up or down until the setting is correct, then retighten the 3 fasteners on the cam lock bracket. Release controls.

REMOTE DEFLECTOR CONTROL

10 HP models are equipped with a Remote Deflector Control. Pushing/Pulling the "T" handle (located on Control Panel) raises/lowers the Deflector Cap - which determines the distance snow is thrown. To lock the Cap in a position, rotate the "T" handle 1/4 turn to the RIGHT.

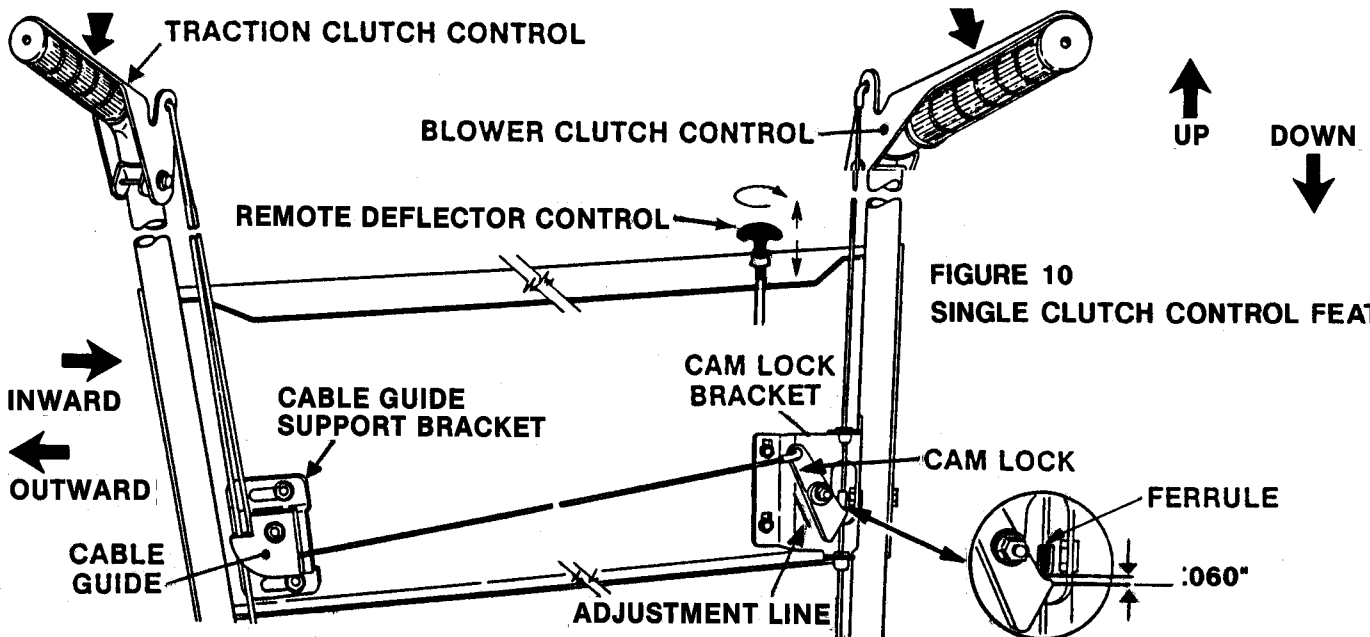
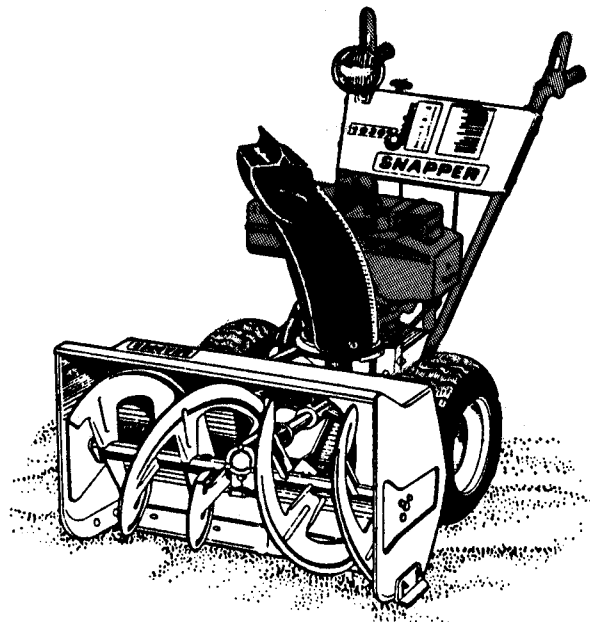

**FIGURE 10
SINGLE CLUTCH CONTROL FEATURE**

SERVICE ASSISTANCE

Contact your **SNAPPER** Dealer for replacement parts or for assistance when service is needed to keep your **SNOW THROWER** in top condition. To obtain the correct parts or advice for your particular model, always report the model and serial numbers as found on the nameplate attached to the frame. For engine parts and service, contact the engine manufacturer's dealer in your area. Complete **PARTS** and **SERVICE** (Overhaul and Repair) Manuals are available for your **SNOW THROWER** at nominal cost. Order these from your **SNAPPER** Dealer.

See your **SNAPPER** Dealer for these Accessories:
Tire Chains
Remote Deflector Control
Add on Light & Alternator Kit



SNAPPER®

2 YEAR LIMITED WARRANTY

For **two (2) years** from purchase date for the original purchaser's **residential**, non-commercial use, **SNAPPER**, through any **SNAPPER** dealer will replace, free of charge, any part or parts found upon examination by the factory at McDonough, Georgia, to be defective in material or workmanship or both.

For **ninety (90) days** from purchase date for the original purchaser's **commercial**, rental, or other non-residential use, **SNAPPER**, through any **SNAPPER** dealer will replace, free of charge, any part or parts found upon examination by the factory at McDonough, Georgia, to be defective in material or workmanship or both.

All transportation costs incurred by the purchaser in submitting material to a **SNAPPER** dealer for replacement under this warranty must be paid by the purchaser.

This warranty does not apply to engines and their components, or, Peerless® Transaxles, as these items are warranted separately by their manufacturers. This warranty does not apply to parts that have been damaged by accident, alteration, abuse, improper lubrication, normal wear, or other cause beyond our control.

There is no other express warranty.

Implied warranties, including those of merchantability and fitness for a particular purpose, are limited to two (2) years from purchase date for the original purchaser's residential, non-commercial use [ninety (90) days from purchase for the original purchaser's commercial, rental or other non-residential use], and to the extent permitted by law, any and all implied warranties are excluded. This is the exclusive remedy. Liabilities for consequential damages, under any and all warranties are excluded.

Some states do not allow limitations on how long an implied warranty lasts, or do not allow the exclusion or limitation of incidental or consequential damages, so the above limitation or exclusion may not apply to you.

This warranty gives you specific legal rights, and you may also have other rights which vary from state to state.

WARNING: THE USE OF REPLACEMENT PARTS OTHER THAN GENUINE SNAPPER PARTS MAY IMPAIR THE SAFETY OF SNAPPER PRODUCTS AND WILL VOID ANY LIABILITY AND WARRANTY BY SNAPPER ASSOCIATED WITH THE USE OF SUCH PARTS.

IMPORTANT: Please fill out the attached **SNAPPER** Product Registration Card immediately and mail to:
SNAPPER, McDONOUGH, GEORGIA 30253

SNAPPER® McDonough, GA., 30253 U.S.A.