

## #6-1014 REMOTE DEFLECTOR CONTROL for SNAPPER LARGE FRAME SNOW THROWERS

**INTRODUCTION:** This kit is to be used on large frame snowthrowers to allow operation of the deflector from operators position.

**INSTALLATION INSTRUCTIONS:** This kit requires a few tools: open end wrenches & drill. Install as follows:

**STEP 1:** Remove control panel and install control panel from kit. Be sure all nut, bolts and controls are tight.

**STEP 2:** Remove nut from engine base on right rear side (as viewed from operators position). Install cable bracket (item 4) over stud and secure with nut. See figure 1.

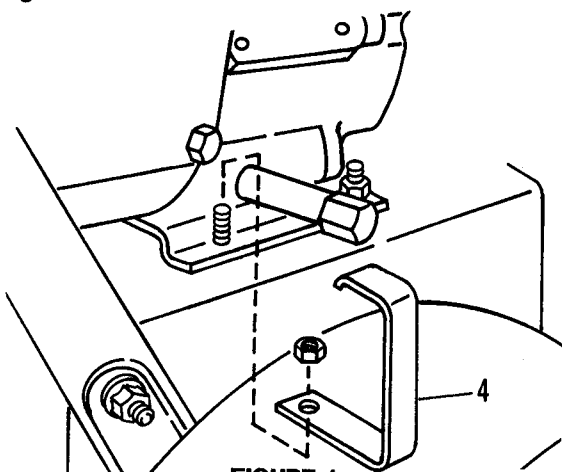

FIGURE 1

**STEP 3:** Using the back of this instruction sheet as a template, drill the two 1/4" holes into the right side (as viewed from the operators position) of chute.

**STEP 4:** Install cable mount (item 3) using two 1/4"x1/2" carriage bolts on inside of chute and secure with two 1/4" internal tooth lock washers and 1/4" hex nuts. See figure 2. Remove wing nut, washer and carriage bolt from left side of deflector and discard. Replace with 5/16x3/4" cap screw, washer and nut found in kit. Position these items the same as the right side and don't overtighten. Deflector has to be free to move up and down.

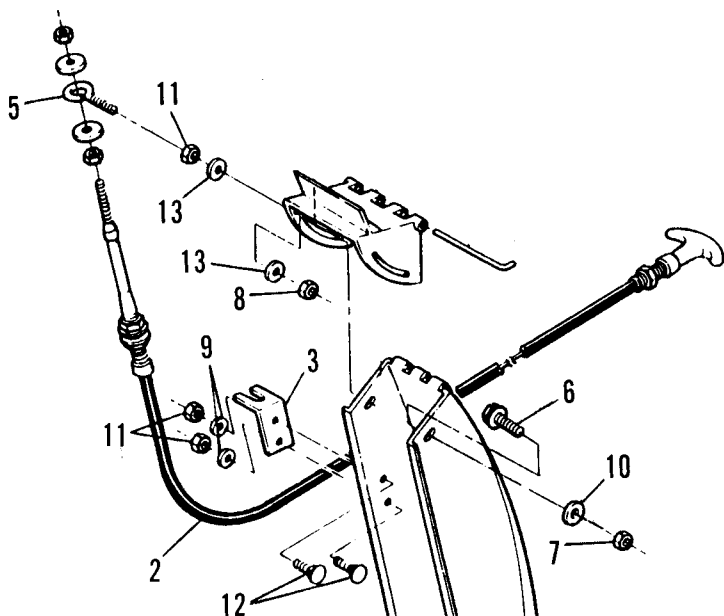

FIGURE 2

INSTRUCTION 1-9379 (I.R. 11/90)

**STEP 5:** Drill 1/4" hole in deflector as shown in figure 3. Insert eyebolt and retaining hardware into hole, do not overtighten, the eye-bolt must pivot smoothly and freely as the deflector moves up and down.

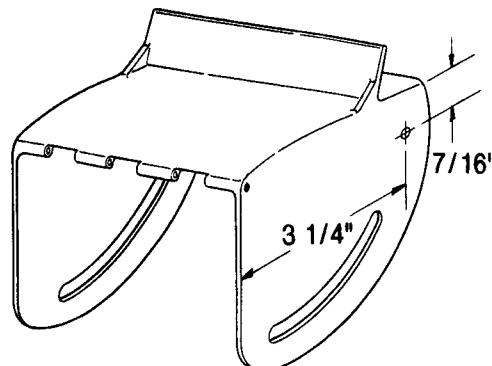

FIGURE 3

**STEP 6:** Insert control cable into control panel, align flat on the threads of cable with flat in panel. See figure 4. Tighten nuts securely. Remove one nut and washer from end of control cable; tighten other nut down onto cable shank. Insert cable into eyebolt as shown and install nut and washer onto cable as shown and tighten securely. Pull handle out to pull deflector down or push handle in to move deflector up. To lock the deflector in the desired position turn handle clockwise 1/4 turn.

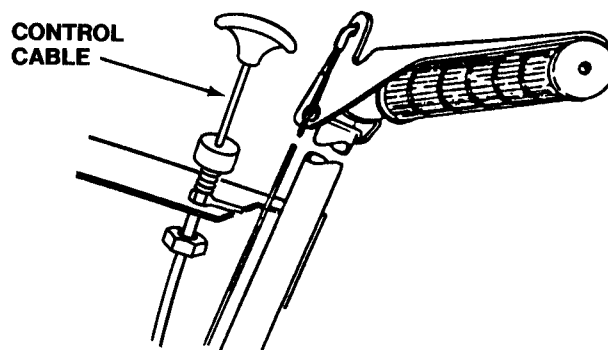
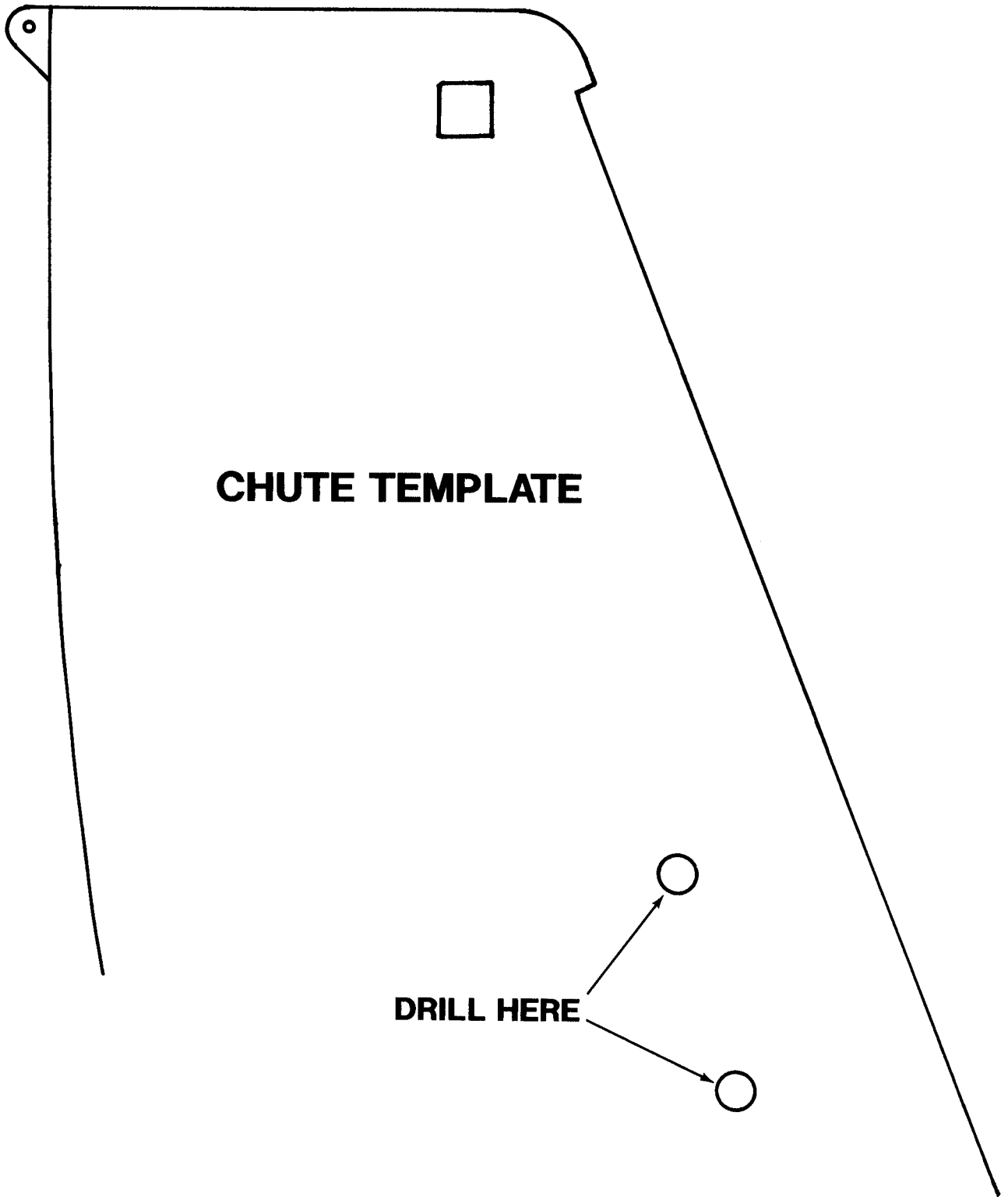

FIGURE 4

### ITEM PART NO. DESCRIPTION

-	6-1014	KIT, Remote Deflector Control (Includes items 1 thru 13)
1	5-2138	ASSEMBLY, Control Panel (NOT SHOWN)
2	1-9161	CABLE, Control
3	3-2813	MOUNT, Cable
4	3-3035	BRACKET, Cable
5	2-3798	BOLT, 1/4-20 Eye
6	9-1021	SCREW, 5/16-24x3/4" Hex Cap
7	9-1074	NUT, 5/16-24 Hex Lock
8	9-1099	NUT, 1/4-20 Hex Center Lock
9	9-1023	WASHER, 1/4 Internal Tooth Lock (2)
10	9-1076	WASHER, 5/16 Flat
11	9-1100	NUT, 1/4-20 Hex (3)
12	9-1064	BOLT, 1/4-20x1/2 Carriage (2)
13	9-1098	WASHER, 1/4 Flat (2)



# CHUTE TEMPLATE

DRILL HERE

**SNAPPER POWER EQUIPMENT**  
McDonough, GA., 30253 U.S.A.

