

# 1900 SERIES

## Attachments & Accessories

Includes  
Deutz-Allis  
Models

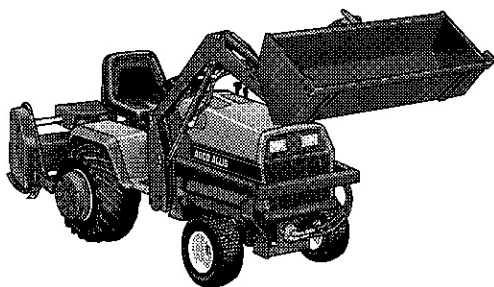

**AGCO ALLIS**

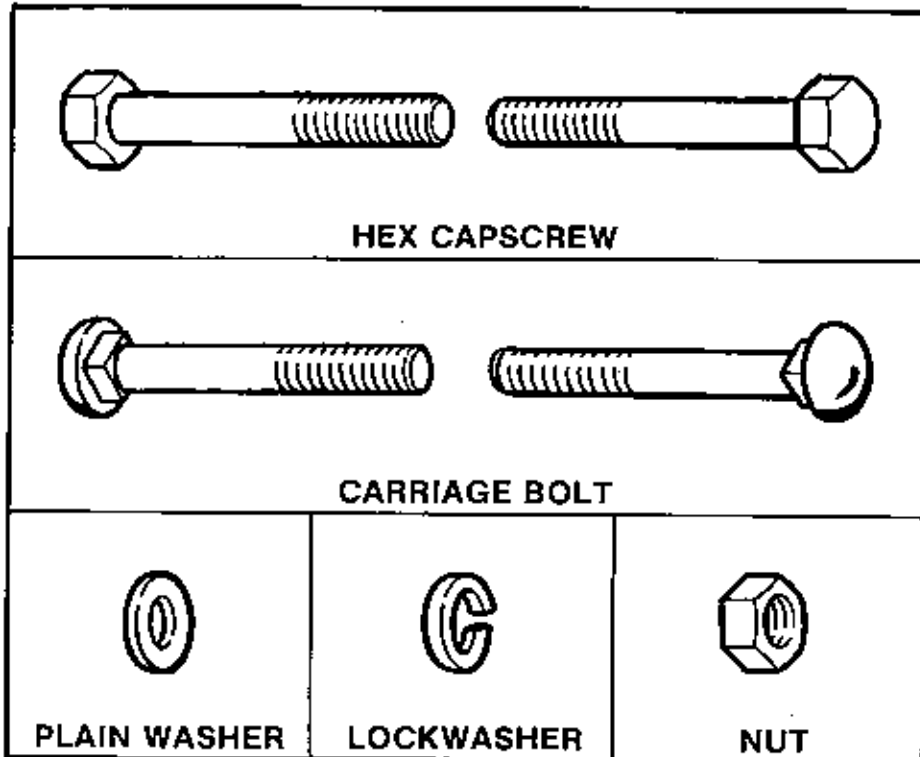

**HEX CAPSCREW**

**CARRIAGE BOLT**

**PLAIN WASHER**

**LOCKWASHER**

**NUT**

**HEX CAPSCREW IDENTIFICATION**

Shown below are actual size hex heads for standard screw sizes. Example: a 1/4" screw has a 7/16" head and thus requires a 7/16" wrench. To measure length, use the scale below.

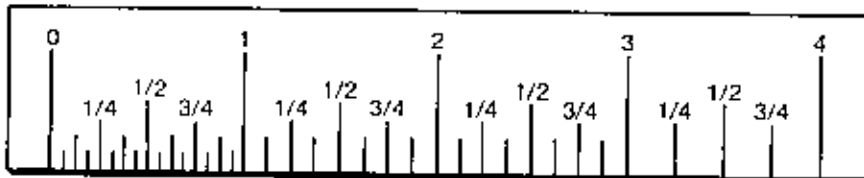
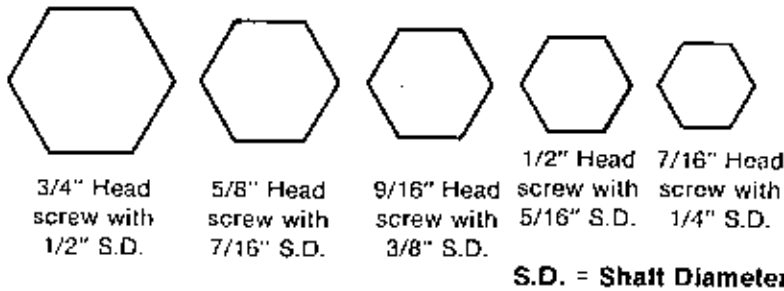

**WASHER AND NUT IDENTIFICATION**

Place the washer or nut on the above scale to determine the inside diameter. The actual inside diameter can vary 1/16 inch. Use the scale for comparison.

**STANDARD FASTENER IDENTIFICATION CHART**

Hardware sizes are given in the illustrations throughout this manual.

If a washer or nut is identified as "washer, 1/2" or "nut, 1/2", this means the inside diameter is 1/2 inch.

If a screw is identified as "screw, 1/2 x 2", this means the shaft diameter is 1/2 inch and the shaft of the screw is 2 inches long. If a screw is identified as "screw, 1/2-16 x 2", the number "16" means that the screw has 16 threads per inch.

**SAMPLE: SCREW IDENTIFICATION**

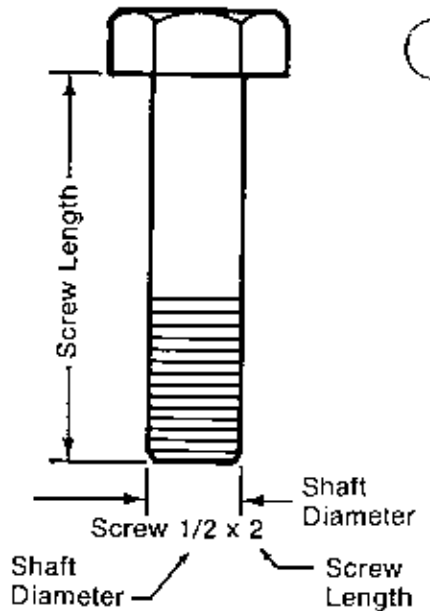

**SAMPLE: NUT IDENTIFICATION**

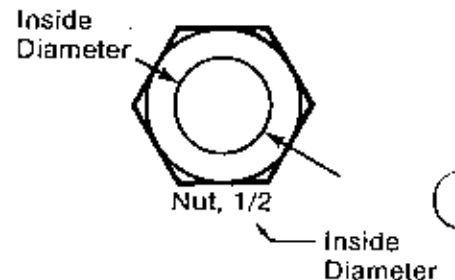

# Table of Contents

Mfg. No	Description	Page
1600236	DUMP CART .....	98
1690401	CART COVER & SIDE EXTENSION GROUP .....	72
1690982	42" SNOWTHROWER	
	Body & Rotor Group .....	34
	Spout Group .....	36
	Drive Group .....	38
	Hitch Group .....	40
	Drive Shaft .....	56
	Right Angle Gear Box (Durst) .....	56
	Right Angle Gear Box (Peerless) .....	58
1690984	60" MOWER	
	Housing & Cover Group .....	16
	Height Adjusting & Roller Group .....	20
	Arbor & Drive Group .....	22
	Deflector Group .....	26
	Decal Group .....	28
	Drive Assy. (Curtis, Durst) .....	30
	Drive Assy. (Peerless) .....	32
	Drive Shaft Group .....	32
1690986	48" MOWER	
	Housing & Cover Group .....	8
	Height Adjusting & Roller Group .....	10
	Arbor & Drive Group .....	12
	Deflector Group .....	14
	Decal Group .....	28
	Drive Assy. (Curtis, Durst) .....	30
	Drive Assy. (Peerless) .....	32
	Drive Shaft Group .....	32
1690989	38" TILLER	
	Chain & Cover Group .....	100
	Clutch & Drive Group .....	102
	Frame, Deflector & Tine Group .....	104
	Hitch & Lift Group .....	108
	Drive Shaft Group .....	110
	Durst Gear Box .....	110
	Peerless Gear Box .....	112
1690990	VACUUM COLLECTOR	
	Blower Housing & Hitch Extension .....	64
	Frame & Drive Group .....	66
	Drive Shaft Group .....	68
1690996	ONE POINT HITCH .....	124
1691000	46" DOZER BLADE	
	Blade Group .....	114
	Hitch Group .....	116
1691002	REAR P.T.O. GROUP .....	130
	Electrical Group .....	140
1691003	REAR LIFT KIT .....	128
1691009	42" MOWER	
	Housing & Cover Group .....	6
	Height Adjusting & Roller Group .....	10
	Arbor & Drive Group .....	12
	Deflector Group .....	14
	Decal Group .....	28
	Drive Assy. (Curtis, Durst) .....	30
	Drive Assy. (Peerless) .....	32
	Drive Shaft Group .....	32

Table of Contents - Continued

Mfg. No	Description	Page
1691010	REAR P.T.O. (2000 RPM)	
	Rear P.T.O. (2000 RPM) (Early Models) .....	132
	Rear P.T.O. (2000 RPM) (Later Models) .....	134
	Electrical Group .....	140
	Peerless Gear Box .....	170
1691170	42" ADAPTOR - VACUUM COLLECTOR .....	70
1691171	48" ADAPTOR - VACUUM COLLECTOR .....	70
1691182	42" MOWER	
	Housing & Cover Group .....	6
	Height Adjusting & Roller Group .....	10
	Arbor & Drive Group .....	12
	Deflector Group .....	14
	Decal Group .....	28
	Drive Assy. (Curtis, Durst) .....	30
	Drive Assy. (Peerless) .....	32
	Drive Shaft Group .....	32
1691183	48" MOWER	
	Housing & Cover Group .....	8
	Height Adjusting & Roller Group .....	10
	Arbor & Drive Group .....	12
	Deflector Group .....	14
	Decal Group .....	28
	Drive Assy. (Curtis, Durst) .....	30
	Drive Assy. (Peerless) .....	32
	Drive Shaft Group .....	32
1691184	60" MOWER	
	Housing & Cover Group .....	16
	Height Adjusting & Roller Group .....	20
	Arbor & Drive Group .....	22
	Deflector Group .....	26
	Decal Group .....	28
	Drive Assy. (Curtis, Durst) .....	30
	Drive Assy. (Peerless) .....	32
	Drive Shaft Group .....	32
1691195	HYDRAULIC KIT .....	164
1691196	REAR LIGHT KIT .....	162
1691257	42" TURBO COLLECTION SYSTEM	
	Blower Group .....	74
	Cover & Support Group .....	86
1691258	48" TURBO COLLECTION SYSTEM	
	Blower Group .....	74
	Cover & Support Group .....	88
1691259	60" TURBO COLLECTION SYSTEM	
	Blower Group .....	80
	Cover & Support Group .....	90
1691309	FRONT LOADER	
	Loader Mounting Kit & Parking Stand .....	144
	Loader Main Frame .....	146
	Ballast Box Group .....	148
	Hydraulic Group, Frame .....	150
	Hydraulic Group, Valve .....	152
	Control Valve .....	154
	Cylinder Assy., Bucket .....	156
	Cylinder Assy., Lift .....	156
	Pedal Group .....	160

Table of Contents - Continued

Mfg. No	Description	Page
*1691310 - 38"	Bucket Group .....	148
*1691311 - 48"	Bucket Group .....	148
*1691313	Single Lever Control Group .....	158
1691316	REAR WEIGHT CARRIER HITCH GROUP .....	166
1691317	FRONT WEIGHT CARRIER .....	166
1691338	BALLAST BOX .....	148
1691339	60" MOWER	
	Housing & Cover Group .....	18
	Height Adjusting & Roller Group .....	20
	Arbor & Drive Group .....	24
	Deflector Group .....	26
	Decal Group .....	28
	Drive Assy. (Curtis, Durst) .....	30
	Drive Assy. (Peerless) .....	32
	Drive Shaft Group .....	32
1691344	60" MOWER	
	Housing & Cover Group .....	18
	Height Adjusting & Roller Group .....	20
	Arbor & Drive Group .....	24
	Deflector Group .....	26
	Decal Group .....	28
	Drive Assy. (Curtis, Durst) .....	30
	Drive Assy. (Peerless) .....	32
	Drive Shaft Group .....	32
1691351	FRONT P.T.O. (540 RPM) .....	142
1691358	WIDE BODY CART COLLECTOR	
	Cart Group .....	94
	Tube & Hitch Group .....	96
1691359	FRONT TIRE (HI-CAP STEERING) GROUP .....	168
1691360	46" SNOWTHROWER	
	Body & Rotor Group .....	42
	Spout Group .....	44
	Spout Rotator Group .....	46
	Drive Group - Early Models (Before Serial No. 00309).....	48
	Drive Group - Later Models (After Serial No. 00308).....	50
	Hitch Group - Early Models (Before Serial No. 00309).....	52
	Hitch Group - Later Models (After Serial No. 00308).....	54
	Drive Shaft Group .....	56
	Gear Assy. ....	60
1691365	46" DOZER BLADE	
	Blade Group .....	114
	Hitch Group .....	120
	Hydraulic Group .....	122
1691366	ELECTRIC SPOUT ROTATOR .....	62
1691409	REAR WHEEL & TIRES GROUP (Turf).....	168
1691410	REAR WHEEL & TIRES GROUP (Ag).....	168
1691456	THREE POINT HITCH .....	126
1691526	WIDE BODY CART COLLECTOR	
	Cart Group .....	94
	Tube & Hitch Group .....	96
1691605	60" TURBO COLLECTION SYSTEM	
	Blower Group .....	82
	Cover & Support Group .....	90

\*These Mfg. Nos. are necessary for the installation of the Front Loader (Mfg. No. 1691309.)

Table of Contents - Continued

Mfg. No	Description	Page
1691606	<b>48" TURBO COLLECTION SYSTEM</b>	
	Blower Group .....	76
	Cover & Support Group .....	88
1691607	<b>42" TURBO COLLECTION SYSTEM</b>	
	Blower Group .....	76
	Cover & Support Group .....	86
1691609	<b>COLLECTION HOSE &amp; HITCH</b>	
	Assembly - 60" .....	92
1691610	<b>COLLECTION HOSE &amp; HITCH</b>	
	Assembly - 42"/48" .....	92
1691735	<b>38" TILLER</b>	
	Chain & Cover Group .....	100
	Clutch & Drive Group .....	102
	Frame, Deflector & Tine Group .....	106
	Hitch & Lift Group .....	108
	Drive Shaft Group .....	110
	Durst Gear Box .....	110
	Peerless Gear Box .....	112
1691765	<b>REAR LIFT KIT</b> .....	128
1691929	<b>FRONT TIRE (Hi-Cap Steering) Group</b> .....	168
1691930	<b>FRONT TIRE (Hi-Cap Steering) Group</b> .....	168
1691986	<b>DUMP CART</b> .....	98
1692002	<b>42" TURBO COLLECTION SYSTEM</b>	
	Blower Group .....	78
	Cover & Support Group .....	86
1692003	<b>48" TURBO COLLECTION SYSTEM</b>	
	Blower Group .....	78
	Cover & Support Group .....	88
1692004	<b>60" TURBO COLLECTION SYSTEM</b>	
	Blower Group .....	84
	Cover & Support Group .....	90
1692229	<b>REAR P.T.O. (2000 RPM)</b> .....	136
	Electrical Group .....	140
1692230	<b>REAR P.T.O. (3400 RPM)</b> .....	138
	Electrical Group .....	140
1692243	<b>47" SNOWTHROWER</b>	
	Gear Box Mounting .....	172
	Gear Box .....	174
	Drive Shaft Subassembly .....	174
	Chute Assy. ....	176
	Handcrank Assy. ....	178
	Rear Skid Shoe Assy. ....	180
	Auger Assy. ....	182
	Gear Box and Shaft Subassemblies .....	184
	Hitch & Lift Group .....	186
	Hitch Assy. ....	188
	Decal Group .....	190
<b>WHOLEGOODS (not shown):</b>		
1690095	<b>CHAINS (Tire)</b>	
1691352	<b>WEIGHTS - (Rear Wheels)</b>	
1691519	<b>ADAPTOR - Vac Collector for 60" Mowers</b>	
1691620	<b>VAC COLLECTOR CART SIDE EXTENSION &amp; COVER (for 17 cu. ft. Cart)</b>	
1691987	<b>DUMP CART (17 cu. ft.)</b>	
1691980	<b>SNOW CAB</b>	
1692241	<b>SNOW CAB</b>	

THIS PAGE INTENTIONALLY BLANK

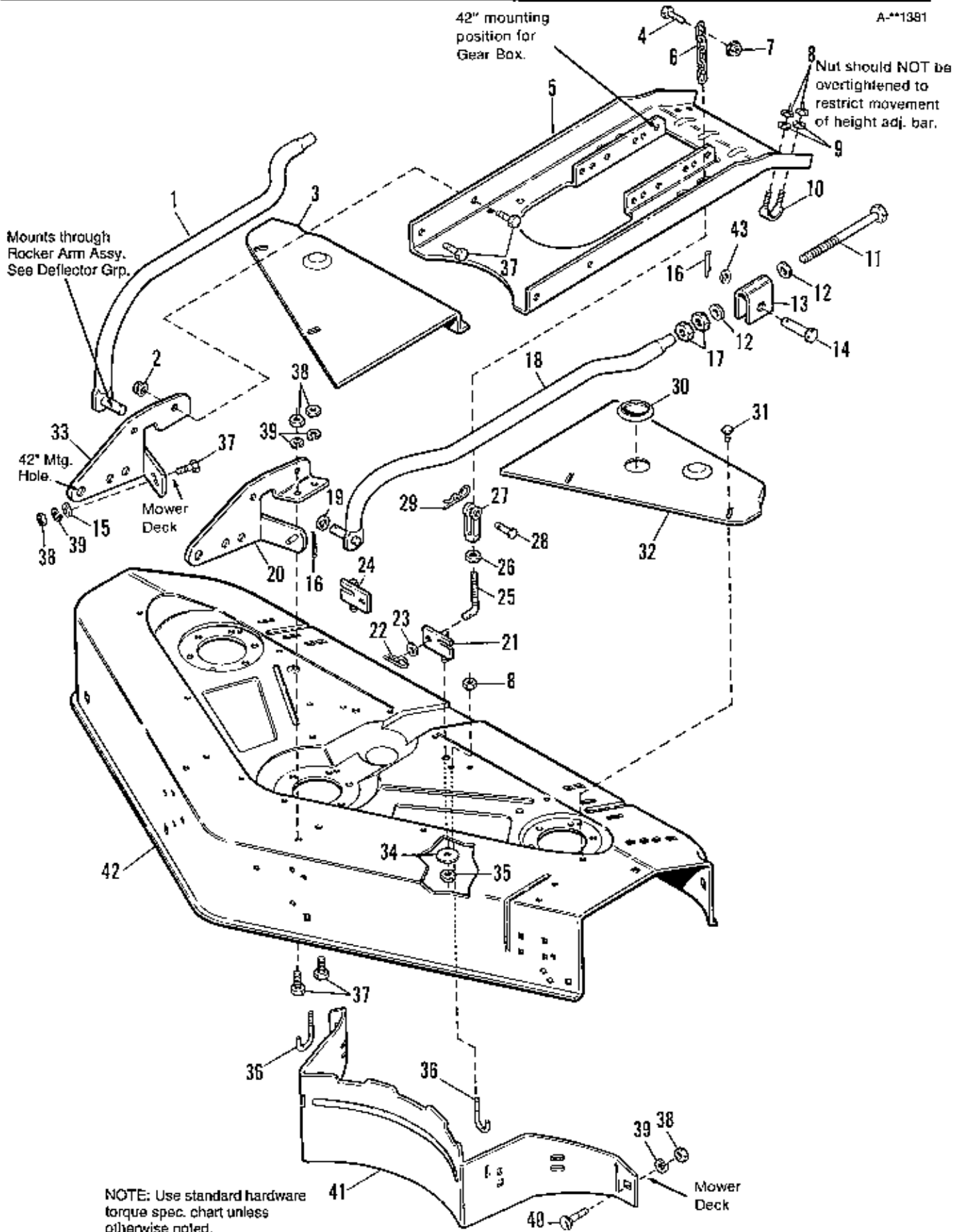

NOTE: Use standard hardware torque spec. chart unless otherwise noted.



## 42" Mower, Housing &amp; Cover Group

Ref. No.	Part No.	Qty.	Description
1	1677191	1	ARM ASSY., R.H.
2	1931211	4	NUT, Hex Whizlock, 3/8-16
3	1676094	1	COVER, Mower, R.H.
4	1921210	2	CAPSCREW, Hex Hd., 3/8-16 x 1
5	1678102	1	SUPPORT, "U" Channel
6	107031	2	CHAIN, 5 Link (Used with 23" Tires)
	1708266	2	CHAIN, 6 Link (Used with 28" Tires)
7	1930645	2	NUT, Hex, Flange, Lock, 3/8-16
8	1923362	6	NUT, Hex, Centerlock, 5/16-18
9	1917642	4	WASHER, 5/16
10	1678623	2	"U" BOLT, 1"
11	1960150	2	CAPSCREW, Hex, 5/8-18 x 5-1/2
12	1924366	4	WASHER, 5/8
13	1677182	2	TRUNNION
14	1960064	2	PIN, Trunnion
15	1917642	4	WASHER, 5/16
16	1918452	4	PIN, Cotter, 1/8 x 1
17	1922014	4	NUT, Hex, Jam, 5/8-18
18	1677190	1	ARM ASSY., L.H.
19	1919387	2	WASHER, 5/8
20	1676036	1	BRACKET ASSY., L.H.
21	1678615	1	BRACKET ASSY., Lift, L.H.
22	1960221	2	PIN, Hair, 1/16" Wire
23	1918326	2	WASHER, Plain, 5/16 x 3/4 x 1/16
24	1678616	1	BRACKET ASSY., Lift, R.H.
25	1678619	2	ROD, Bolt, Lift Chain
26	1920161	2	NUT, Hex, Jam, 5/16-18
27	1673575	2	CLEVIS, Lift
28	1673574	2	PIN, Clevis
29	1960074	2	CLIP, Hair Pin
30	1674020	1	PLUG, Mower Cover
31	1929000	6	SCREW, Hex, Taplike, 1/4-20 x 3/8
32	1676093	1	COVER, Mower, L.H.
33	1676035	1	BRACKET ASSY., R.H.
34	1924356	2	WASHER, Plain, 13/32 x 1-1/2 x 1/8
35	1930651	2	NUT, Hex, Centerlock, 3/8-16
36	1679385	2	SCREW, Baffle Hook
37	1921966	12	CAPSCREW, Hex, 3/8-16 x 7/8
38	1916950	10	NUT, Hex, 3/8-16
39	1916965	10	LOCKWASHER, 3/8
40	1931349	2	BOLT, Carriage, 3/8-16 x 7/8
41	1675587	1	BAFFLE, Mower
42	* 1685281	1	HOUSING, 42" Mower
43	1924361	2	WASHER, 1/2"

\* 1685281 is an orange deck  
 71685281 is a green deck  
 61685281 is a black deck

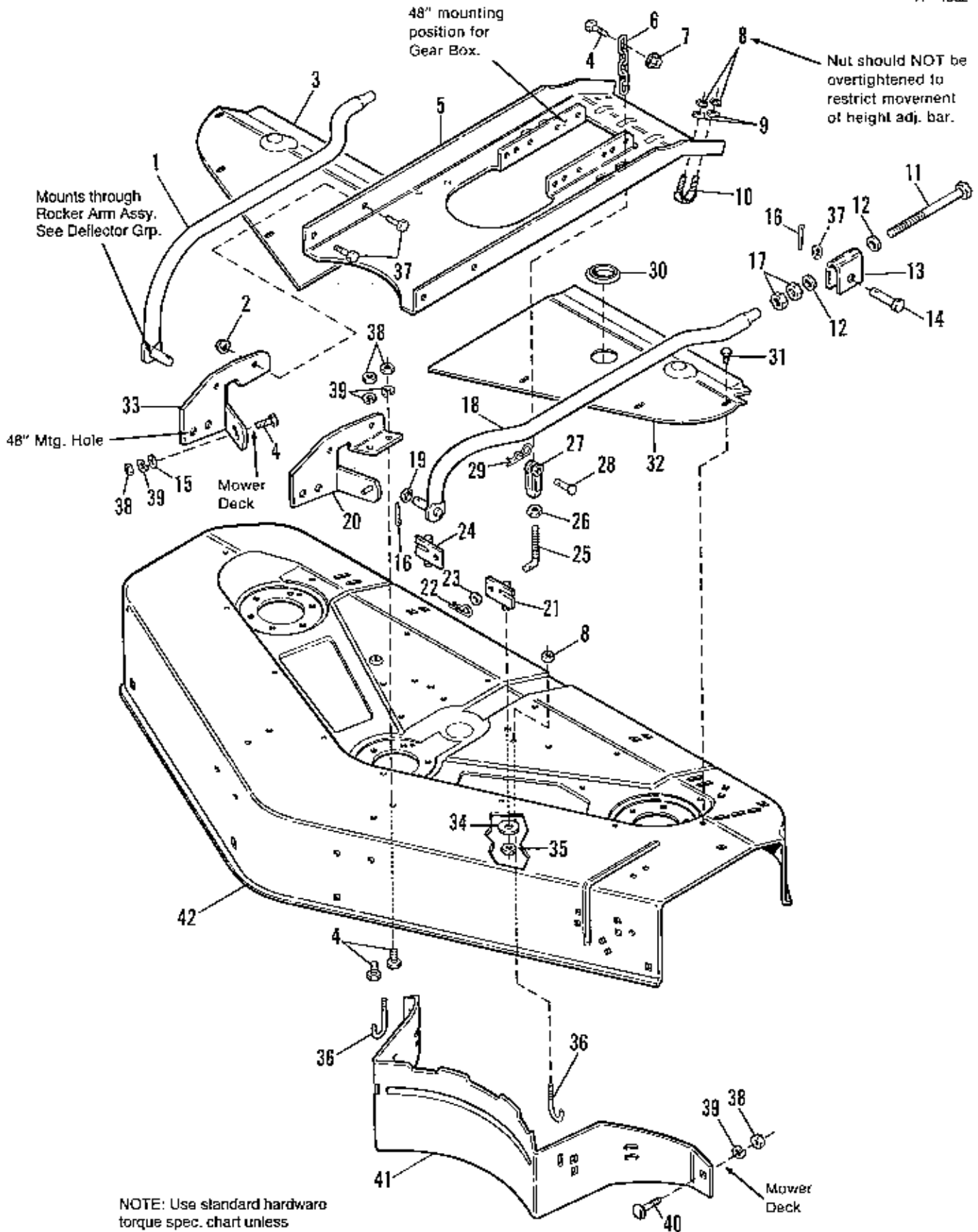

## 48" Mower, Housing &amp; Cover Group

Ref. No.	Part No.	Qty.	Description
1	1677189	1	ARM ASSY., R.H.
2	1931211	4	NUT, Hex Whizlock, 3/8-16
3	1679928	1	COVER, Mower, R.H.
4	1921210	14	CAPSCREW, Hex Hd., 3/8-16 x 1
5	1678101	1	SUPPORT, "U" Channel
6	107031	2	CHAIN, 5 Link (Used with 23" Tires)
	1708266	2	CHAIN, 6 Link (Used with 26" Tires)
7	1930645	2	NUT, Hex, Flange, Lock, 3/8-16
8	1923362	6	NUT, Hex, Centerlock, 5/16-18
9	1919326	4	WASHER, 11/32
10	1678623	2	"U" BOLT, 1"
11	1960150	2	CAPSCREW, Hex, 5/8-18 x 5-1/2
12	1924366	4	WASHER, 5/8
13	1677182	2	TRUNNION
14	1960064	2	PIN, Trunnion
15	1924940	4	WASHER, 13/32
16	1918452	4	PIN, Cotter, 1/8 x 1
17	1922014	4	NUT, Hex, Jam, 5/8-18
18	1677188	1	ARM ASSY., L.H.
19	1960020	2	WASHER, 21/32
20	1677353	1	BRACKET ASSY., L.H.
21	1678615	1	BRACKET ASSY., Lift, L.H.
22	1960221	2	PIN, Hair, 1/16" Wire
23	1919326	2	WASHER, Plain, 5/16 x 3/4 x 1/16
24	1678616	1	BRACKET ASSY., Lift, R.H.
25	1678619	2	ROD, Bolt
26	1920161	2	NUT, Hex, Jam, 5/16-18
27	1673575	2	CLEVIS, Lift
28	1673574	2	PIN, Clevis
29	1960074	2	CLIP, Hair Pin
30	1674020	1	PLUG, Mower Cover
31	1929000	10	SCREW, Hex, Taptite, 1/4-20 x 3/8
32	1679511	1	COVER, Mower, L.H.
33	1677354	1	BRACKET ASSY., R.H.
34	1924356	2	WASHER, Plain, 13/32 x 1-1/2 x 1/8
35	1930651	2	NUT, Hex, Centerlock, 3/8-16
36	1679385	2	SCREW, Baffle Hook
37	1924361	2	WASHER, 1/2"
38	1916950	10	NUT, Hex, 3/8-16
39	1916965	10	LOCKWASHER, 3/8
40	1931350	2	BOLT, Carriage, 3/8-16 x 1
41	1674774	1	BAFFLE, Mower
42	* 1685282	1	HOUSING, 48" Mower

\* 1685282 is an orange deck  
 71685282 is a green deck  
 61685282 is a black deck



## 42" &amp; 48" Height Adjusting &amp; Roller Group

Ref. No.	Part No.	Qty.	Description
1	1650157	1	BUTTON, Lift Handle
2	156209	1	GRIP, Lift Handle
3	1918265	3	WASHER, 5/16
4	1676526	1	SPRING
5	1922127	1	CAPSCREW, 5/16-18 x 1-3/4
6	1675721	1	ROD LATCH
7	1675710	1	LIFT HANDLE TUBE
8	1916950	16	NUT, Hex, 5/8-16
9	1916965	16	LOCKWASHER, 5/8
10	1931350	2	BOLT, Carriage, 3/8-16 x 1, Gr. 5
11	1677650	1	BRACE, Quadrant (42" Mower)
	1677651	1	BRACE, Quadrant (48" Mower)
12	1917372	6	NUT, Hex, 5/16-18
13	1917356	6	LOCKWASHER, 5/16
14	1676498	1	SPACER
15	1676490	1	LATCH
16	1923362	1	LOCKNUT, Hex, 5/16-18
17	1918451	1	PIN, Cotter, 1/8 x 3/4
18	1676140	1	QUADRANT
19	1921333	1	CAPSCREW, Hex Hd., 5/16-18 x 1
20	1678148	1	CAPSCREW, Flat Hd., Hex Socket, 5/16-18 x 1
21	1924940	5	WASHER, 13/32
22	1921210	1	CAPSCREW, 3/8-16 x 1
23	1931350	8	BOLT, Carriage, 3/8-16 x 1
24	1931352	2	BOLT, Carriage, 3/8-16 x 1-1/2
25	1960144	2	SCREW, Whizlock, 3/8-18 x 5/8
26	1676141	1	SHAFT ASSY., Rocker (42" Mower)
	1676143	1	SHAFT ASSY., Rocker (48" Mower)
27	1676088	2	SPACER
28	1676087	2	STRAP
29	1931355	2	BOLT, Carriage, 3/8-16 x 2-1/4
30	174870	2	SPACER
31	1674660	2	SPACER
32	172622	2	BOLT, Shoulder, 3/8-16 x 1-5/32
33	1924361	2	WASHER, Plain, 1/2 x 1-1/4 x 3/8
34	1677507	2	SLIDE
35	1918458	4	PIN, Cotter, 3/16 x 1
36	1960020	8	WASHER, 21/32
37	1676652	1	SPACER (42" Mower Only)
38	1676502	3	SPACER (Qty. 2 on 42" Mower)
39	1931333	4	BOLT, Carriage, 5/16-18 x 3/4
40	108224	1	BRACKET, Roller, L.H.
41	1668513	10	ROLLER
42	108426	1	BRACKET & SHAFT ASSY. (42" Mower)
	108454	1	BRACKET & SHAFT ASSY. (48" Mower)
43	1676136	1	BAR ASSY., Roller
44	1928721	1	SETSCREW, Sq. Hd., 5/16 x 1/2
45	1676134	1	SHAFT ASSY., Roller (42" Mower)
	1676136	1	SHAFT ASSY., Roller (48" Mower)
46	1676078	1	BRACKET, Roller, R.H.



## 42" &amp; 48" Mowers, Arbor &amp; Drive Group

Ref. No.	Part No.	Qty.	Description
1	1674213	1	SHAFT ASSY., Telescoping (See page 32 for Service Parts)
2	1923358	2	NUT, Hex, Lock, 1/4-20
3	1925688	1	CAPSCREW, Hex, 1/4-20 x 3
4	922138	2	KEY, Hi-Pro
5	1674642	1	DRIVE ASSY., Right Angle (See page 30 for Durst & Curtis Service Parts & page 32 for Peerless Service parts. Name is stamped on housing of gear box.)
6	1916965	4	LOCKWASHER, 3/8
7	1921965	4	CAPSCREW, 3/8-16 x 3/4
8	1674671	1	SPRING
9	1679487	1	ROD, Spring
10	1928731	1	LOCKNUT, Hex, Jam, 3/8-16
11	1679486	1	IDLER STOP
12	1916803	1	LOCKWASHER, Internal
13	1704314	3	GREASE FITTING
14	1674643	1	PULLEY ASSY., Drive
15	1928721	2	SETSCREW, Sq. Hd., 5/16 x 1/2
16	1674670	1	PULLEY, Idler
17	1960268	1	BOLT, Carriage, 3/8-16 x 1-1/4
18	1924940	7	WASHER, 13/32
19	1676148	2	BUSHING
20	1674669	1	SPACER
21	1700395	1	LEVER ASSY., Idler
22	918186	1	FITTING, Lube
23	1921971	1	CAPSCREW, Hex, 3/8-16 x 1-3/4
24	1923491	6	CAPSCREW, Hex, 7/16-14 x 1
25	1918199	3	LOCKWASHER, 7/16
26	1933263	3	WASHER, 7/16
27	1678681	3	PULLEY ASSY., Arbor Drive (42" Mower)
	1678663	3	PULLEY ASSY., Arbor Drive (48" Mower)
28	1657969	3	SHIELD, Bearing, Upper
29	1655729	3	ARBOR HOUSING, Top
30	108202	6	BEARING, Arbor
31	1676277	3	SHAFT, Arbor
32	1676278	3	ARBOR SHAFT & BEARING ASSY. (Incl. Ref. Nos. 30 & 31)
33	1675282	1	BELT, Arbor Drive (42" Mower)
	1675342	1	BELT, Arbor Drive (48" Mower)
34	1703273	3	ARBOR HOUSING, Bottom
35	1664847	18	SCREW, Hex, Taptite, 5/16-18 x 3/4
36	1700230	3	WASHER, Shim
37	1700229	3	SHIELD, Grass
38	1655777	3	ADAPTOR, Blade
39	1657528	3	RING, Self-Locking
40	1679917	3	BLADE, 42" Mower
	1679916	3	BLADE, 48" Mower
41	1679711	3	WASHER, Spline
42	1656916	3	WASHER, Spring
43	1928731	1	NUT, Hex, Top lock, Jam, 3/8-16
44	1930543	1	SETSCREW, Hex, 5/16-18 x 1/2
45	1707335	3	GASKET, Foam

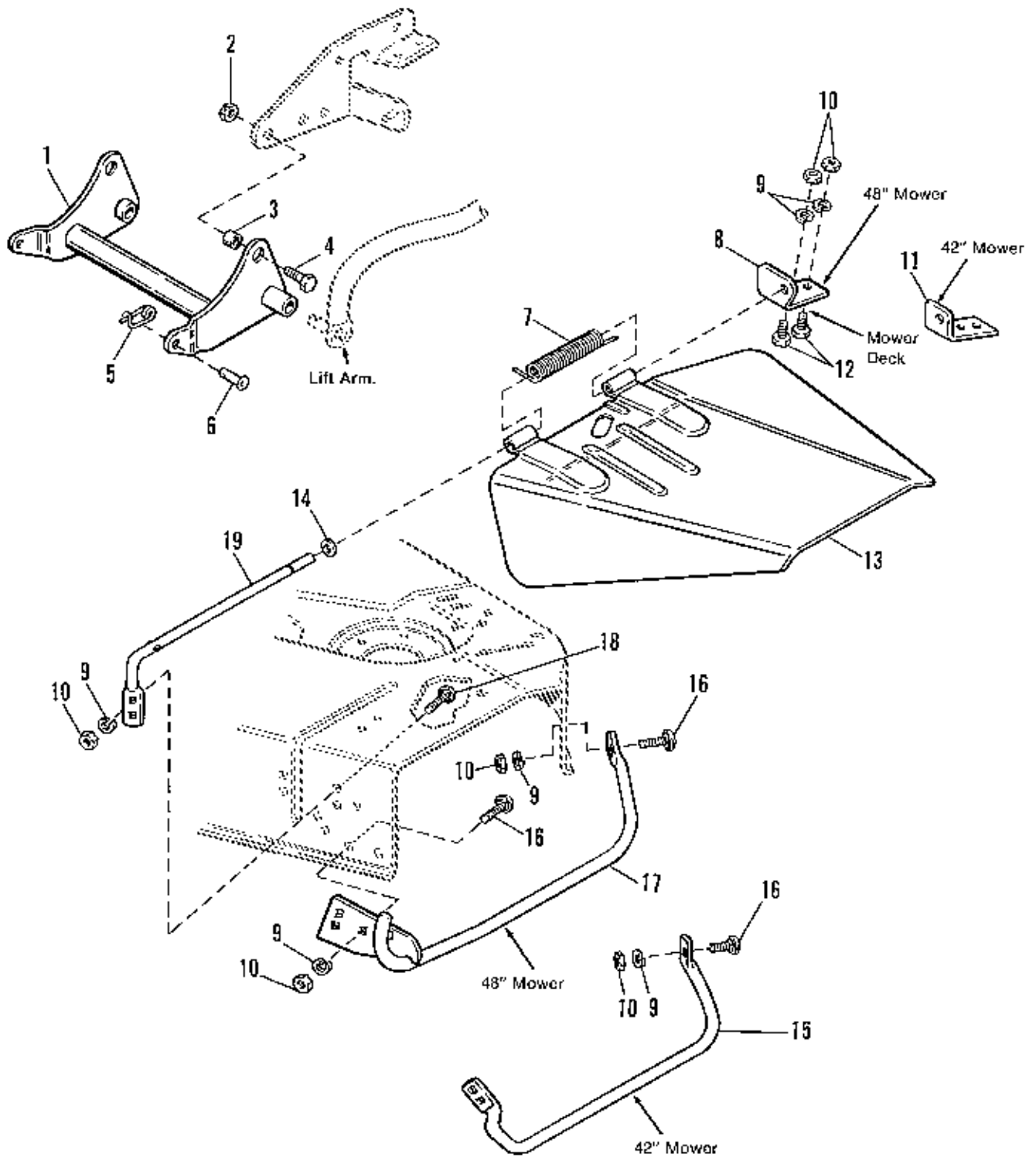

NOTE: Use standard hardware torque spec. chart unless otherwise noted.



## 42" &amp; 48" Mowers, Deflector Group

Ref. No.	Part No.	Qty.	Description
1	1674678	1	ARM ASSY., Rocker
2	1922134	2	LOCKNUT, Hex, 1/2-13
3	1676097	2	SPACER (Rocker Arm)
4	1921176	2	CAPSCREW, Hex, 1/2-13 x 1-1/4
5	176012	2	CLIP, Pin, Safety
6	156306	2	PIN, 3/8 x 1-1/2
7	1676213	1	SPRING, Torsion
8	1676203	1	BRACKET, Rod (48" Mower)
9	1916965	7	LOCKWASHER, 3/8
10	1916950	7	NUT, Hex, 3/8-16
11	1676380	1	BRACKET, Rod (42" Mower)
12	1921210	2	CAPSCREW, Hex, 3/8-16 x 1
13	1677157	1	DEFLECTOR ASSY.
14	1925125	1	WASHER, 7/16
15	1677223	1	STONE GUARD (42" Mower)
16	1931350	3	BOLT, Carriage, 3/8-16 x 1
17	1677261	1	STONE GUARD ASSY., (48" Mower)
18	1931349	2	BOLT, Carriage, 3/8-16 x 7/8
19	1676207	1	ROD, Hinge (42")
	1676208	1	ROD, Hinge (48")

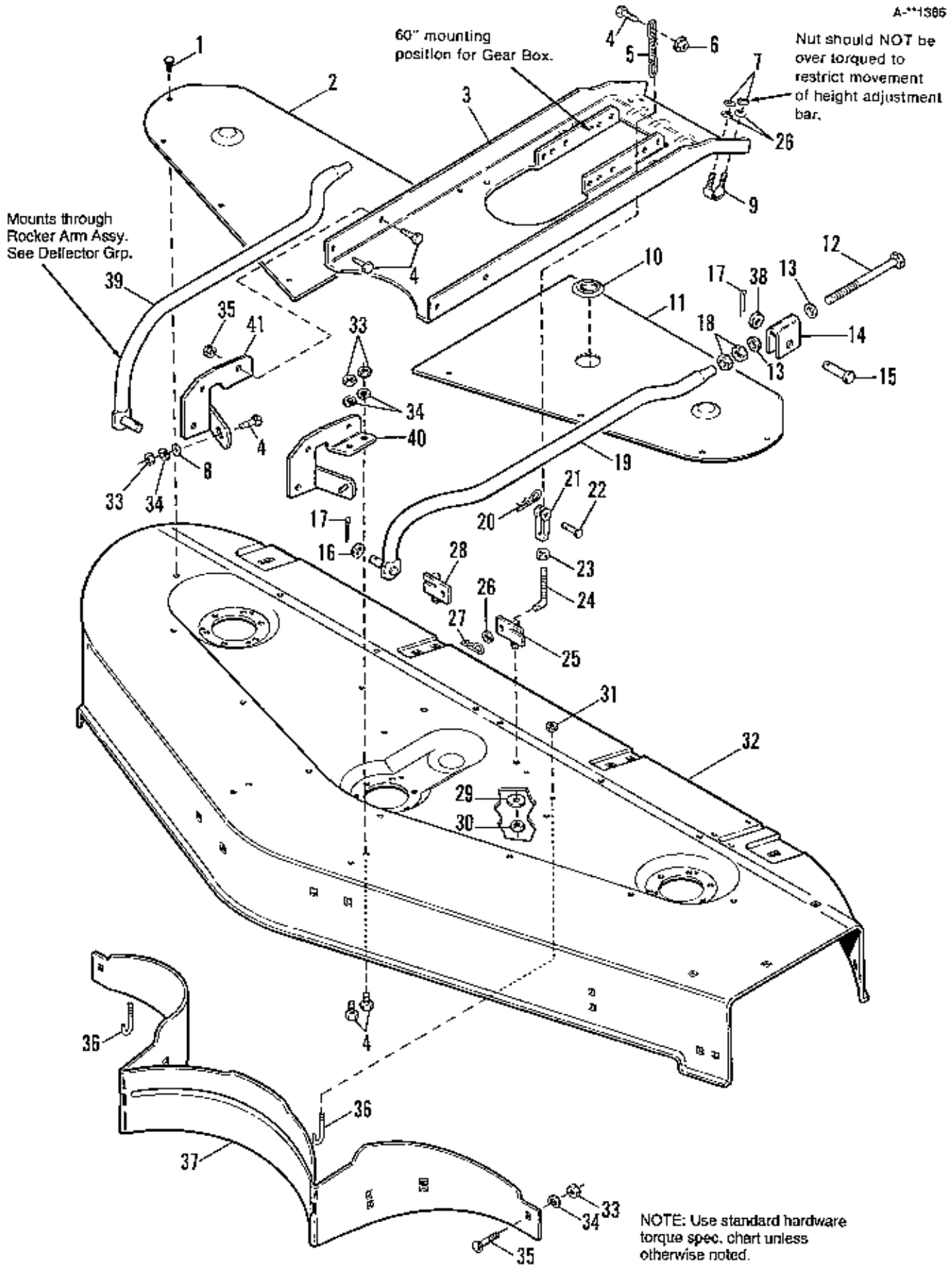

## 60" Mower, Housing &amp; Cover Group

Ref. No.	Part No.	Qty.	Description
1	1929000	10	SCREW, Hex, Taplite, 1/4-20 x 3/8
2	1676125	1	COVER, Mower, R.H.
3	1678181	1	SUPPORT, "U" Channel
4	1921210	12	CAPSCREW, Hex Hd., 3/8-16 x 1
5	107031	2	CHAIN, 5 Link (Used with 23" Tires)
	1708266	2	CHAIN, 6 Link (Used with 26" Tires)
6	1930645	2	NUT, Hex, Flange lock, 3/8-16
7	1923362	4	NUT, Centerlock, 5/16-18
8	1924940	4	WASHER, 13/32
9	1678103	2	CLAMP, "U"
10	1674020	1	PLUG, Mower Cover, L.H.
11	1676126	1	COVER, Mower, L.H.
12	1960150	2	CAPSCREW, Hex, 5/8-18 x 5-1/2
13	1924366	4	WASHER, 5/8
14	1677182	2	TRUNNION
15	1960064	2	PIN, Trunnion
16	1960020	2	WASHER, 5/8
17	1918452	4	PIN, Cotter, 1/8-1
18	1922014	4	NUT, Hex, Jam, 5/8-18
19	1677174	1	ARM ASSY., L.H.
20	1960074	2	CLIP, Hair Pin
21	1673575	2	CLEVIS, Lift
22	1673574	2	PIN, Rivet, Clevis
23	1920161	2	NUT, Hex, Jam, 5/16-18
24	1678619	2	ROD, Bolt
25	1678615	1	BRACKET ASSY., Lift, L.H.
26	1919326	6	WASHER, Plain, 5/16 x 3/4 x 1/16
27	1960221	2	CLIP, Hair Pin
28	1678616	1	BRACKET ASSY., Lift, R.H.
29	1924356	2	WASHER, Plain, 13/32 x 1-1/2 x 1/8
30	1930651	2	NUT, Hex, Centerlock, 3/8-16
31	1923362	2	NUT, Hex, Centerlock, 5/16-18
32	* 1685285	1	HOUSING, 60" Mower (Incl. Safety Decals)
33	1916950	10	NUT, Hex, 3/8-16
34	1916965	10	LOCKWASHER, 3/8
35	1931211	4	NUT, Hex, Whizlock, 3/8-16
36	1679385	2	"J" HOOK
37	1676020	1	BAFFLE, Mower
38	1924361	2	WASHER, Plain, 17/32
39	1677175	1	ARM ASSY., R.H.
40	1676040	1	BRACKET ASSY., L.H.
41	1676039	1	BRACKET ASSY., R.H.

\* 1685285 is an orange deck  
71685285 is a green deck

NOTE: Gauge Wheel Kit 1685316 is available to update Mfg. No. 1690984 units. See pages 18 & 19, Ref. Nos. 46, 47 & 48 and hardware for component and/or replacement parts.

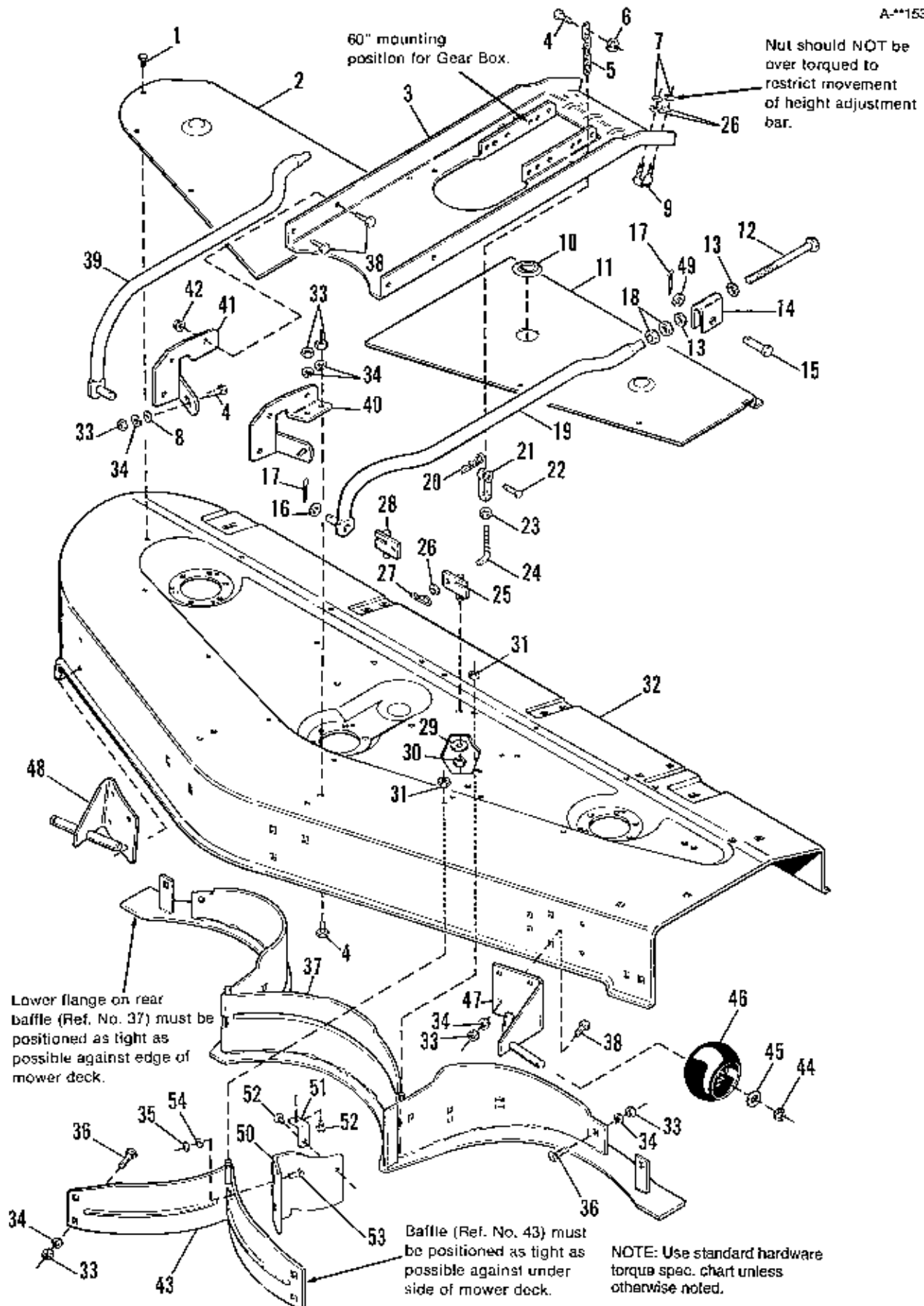

## 60" Mower, Housing &amp; Cover Group

Ref. No.	Part No.	Qty.	Description
1	1929000	9	SCREW, Hex, Taptite, 1/4-20 x 3/8
2	1676125	1	COVER, Mower, R.H.
3	1678181	1	SUPPORT, "U" Channel
4	1921210	12	CAPSCREW, Hex Hd., 3/8-16 x 1
5	107031	2	CHAIN, 5 Link (Used with 23" Tires)
	1708266	2	CHAIN, 6 Link (Used with 26" Tires)
6	1930645	2	NUT, Hex, Flange lock, 3/8-16
7	1923362	4	NUT, Centerlock, 5/16-18
8	1924940	4	WASHER, 11/32
9	1678103	2	CLAMP, "U"
10	1674020	1	PLUG, Mower Cover, L.H.
11	1700273	1	COVER, Mower, L.H.
12	1960150	2	CAPSCREW, Hex, 5/8-18 x 5-1/2
13	1924366	4	WASHER, 5/8
14	1677182	2	TRUNNION
15	1960064	2	PIN, Trunnion
16	1960020	2	WASHER, 21/32
17	1918452	4	PIN, Cotter, 1/8-1
18	1922014	4	NUT, Hex, Jam, 5/8-16
19	1677174	1	ARM ASSY., L.H.
20	1960074	2	CLIP, Hair Pin
21	1673575	2	CLEVIS, Lift
22	1673574	2	PIN, Rivet, Clevis
23	1920161	2	NUT, Hex, Jam, 5/16-18
24	1678619	2	ROD, Bolt
25	1678615	1	BRACKET ASSY., Lift, L.H.
26	1919326	6	WASHER, Plain, 5/16 x 3/4 x 1/16
27	1960221	2	CLIP, Hair Pin
28	1678616	1	BRACKET ASSY., Lift, R.H.
29	1924356	2	WASHER, Plain, 13/32 x 1-1/2 x 1/8
30	1930651	2	NUT, Hex, Centerlock, 3/8-16
31	1923362	3	NUT, Hex, Centerlock, 5/16-18
32	1685308	1	HOUSING, 60" Mower (Incl. Safety Decals)
33	1916950	20	NUT, Hex, 3/8-16
34	1916965	20	LOCKWASHER, 3/8
35	1917372	2	Nut, Hex, 5/16-18
36	1931350	8	CARRIAGE BOLT, 3/8-16 x 1
37	1702412	1	BAFFLE, Mower
38	1921966	8	CAPSCREW, Hex, 3/8-16 x 7/8
39	1677175	1	ARM ASSY., R.H.
40	1676040	1	BRACKET ASSY., L.H.
41	1676039	1	BRACKET ASSY., R.H.
42	1931211	4	NUT, Hex, Whizlock, 3/8-16
43	1702410	1	BAFFLE ASSY., Front
44	960386	2	RING, Retaining, Ext., 1/2
45	1960170	2	WASHER, Plain, 1/2 x 1
46	1700184	2	GAUGE WHEEL
47	1705078	1	BRACKET ASSY., Gauge Wheel, L.H.
48	1705079	1	BRACKET ASSY., Gauge Wheel, R.H.
49	1924361	2	WASHER, Plain
50	1702374	1	BAFFLE, Discharge
51	1668500	1	BRACKET, Mower
52	1924856	2	SCREW, Taptite, 5/16-18 x 1/2
53	1931333	2	BOLT, Carriage, 5/16-18 x 3/4
54	1917356	2	LOCKWASHER

\* 1685308 is an orange deck  
 71685308 is a green deck  
 61685308 is a black deck

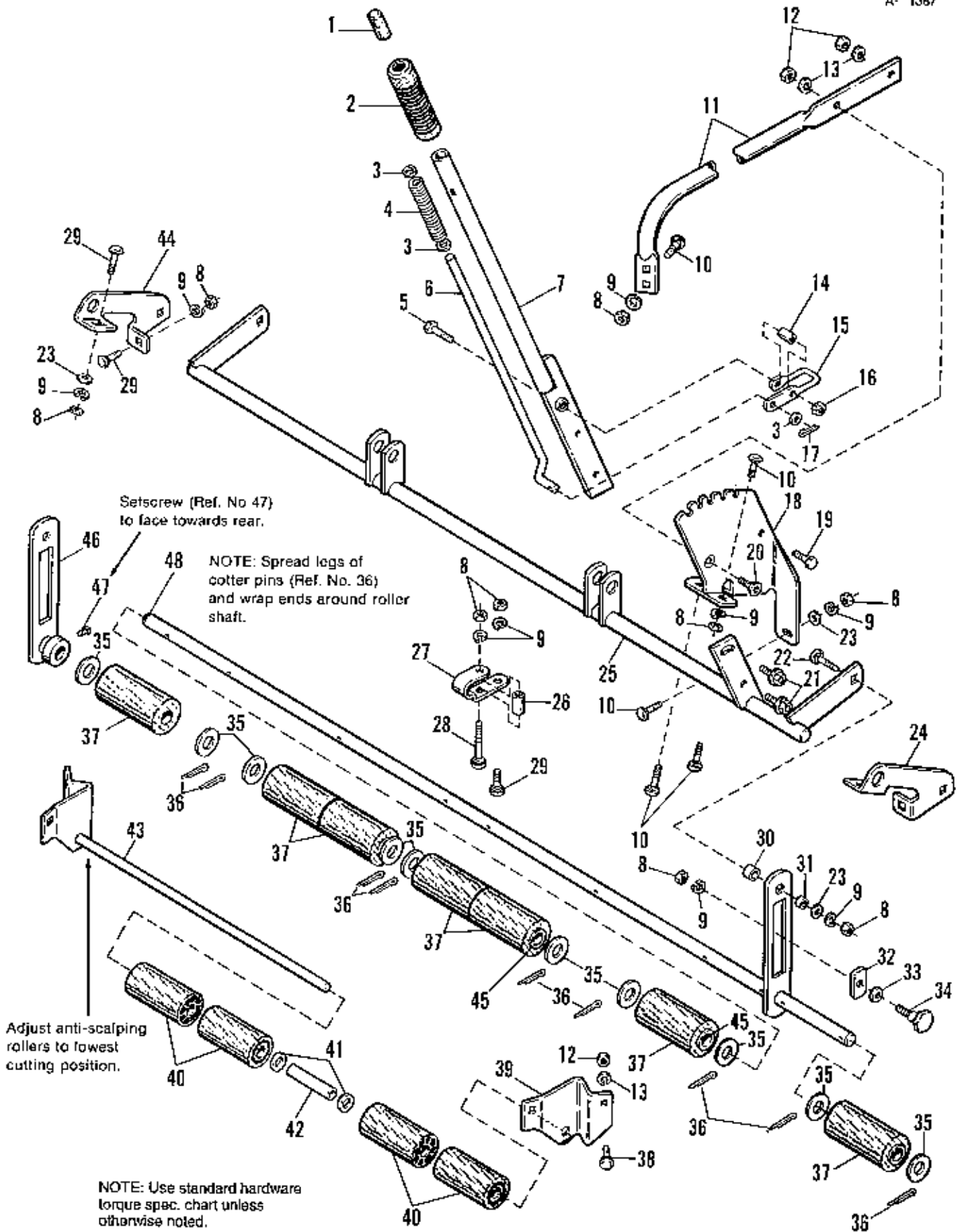

## 60" Mower, Height Adjusting &amp; Roller Group

Ref. No.	Part No.	Qty.	Description
1	1650157	1	BUTTON, Lift
2	156209	1	GRIP, Lift
3	1918265	3	WASHER, 5/16
4	1676526	1	SPRING
5	1922127	1	CAPSCREW, 5/16-18 x 1-3/4
6	1675721	1	ROD, Latch
7	1675710	1	LIFT HANDLE, Tube
8	1916950	18	NUT, Hex, 3/8-18
9	1916965	18	LOCKWASHER, 3/8
10	1931350	6	BOLT, Carriage, 3/8-16 x 1
11	1677652	1	BRACE, Quadrant
12	1917372	6	NUT, Hex, 5/16-18
13	1917356	6	LOCKWASHER, 5/16
14	1676498	1	SPACER
15	1676490	1	LATCH
16	1923362	1	LOCKNUT, Hex, 5/16-18
17	1918451	1	PIN, Cotter, 1/8 x 3/4
18	1676330	1	QUADRANT ASSY.
19	1921333	1	CAPSCREW, Hex Hd., 5/16-18 x 1
20	1678148	1	CAPSCREW, Flat Hd., Hex Socket, 5/16-18 x 1
21	1960144	2	SCREW, Whizlock, 3/8-16 x 5/8
22	1931352	2	BOLT, Carriage, 3/8-16 x 1-1/2
23	1924940	5	WASHER, 13/32
24	1676079	1	BRACKET, Roller, L.H.
25	1676089	1	SHAFT & LEVER ASSY.
26	1676088	2	SPACER (Strap)
27	1676087	2	STRAP
28	1931355	2	BOLT, Carriage, 3/8-16 x 2-1/4
29	1931350	2	BOLT, Carriage, 3/8-16 x 1
30	174870	2	SPACER (Shaft Assy.)
31	1674660	2	SPACER, (Shaft Assy.)
32	1677507	2	SLIDE
33	1924361	2	WASHER, Plain, 1/2 x 1-1/4
34	172622	2	BOLT, Shoulder, 3/8-16 x 1-5/32
35	1960201	10	WASHER, 1"
36	1918459	9	PIN, Cotter, 3/16 x 1-1/2
37	1678043	7	ROLLER ASSY. (Incl. Ref. No. 45)
38	1931333	4	BOLT, Carriage, 5/16-18 x 3/4
39	173270	1	BRACKET ASSY., Roller, L.H.
40	1668513	4	ROLLER
41	1960020	2	WASHER, 21/32
42	1676149	1	SPACER
43	1676404	1	BRACKET & SHAFT ASSY.
44	1676078	1	BRACKET, Roller, R.H.
45	1677762	10	BUSHING
46	1676075	1	BAR ASSY., Roller
47	1928721	1	SETSCREW, Sq. Hd.
48	1676072	1	SHAFT ASSY., Roller

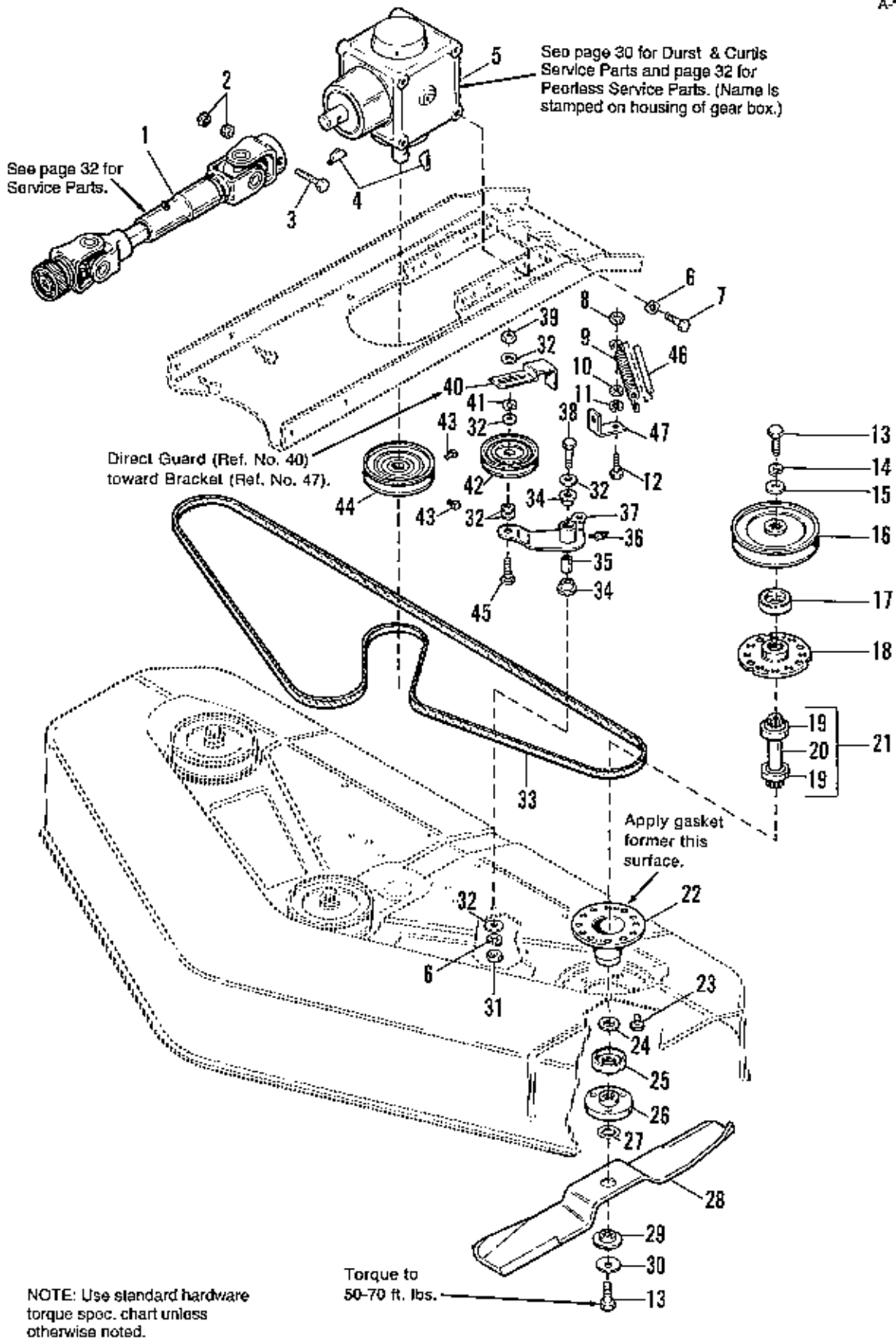



Ref. No.	Part No.	Qty.	Description
1	1674213	1	DRIVE SHAFT ASSY., Telescoping (See page 32 for Service Parts)
2	1923358	2	LOCKNUT, Hex, 1/4-20
3	1925688	1	CAPSCREW, Hex, 1/4-20 x 3
4	922138	2	KEY, Hi-Pro
5	1674642	1	RIGHT ANGLE GEAR CASE ASSY. (See page 30 for Durst & Curtis Service Parts, & page 32 for Peerless Service Parts. Name is stamped on housing of gear box.)
6	1916965	6	LOCKWASHER, 5/8
7	1921965	4	CAPSCREW, Hex, 3/8-16 x 3/4
8	1923362	1	LOCKNUT, Hex, 5/16-18
9	1674671	1	SPRING
10	1917372	1	Nut, Hex, 5/16-18
11	1917356	1	LOCKWASHER, 5/16
12	1921333	1	CAPSCREW, Hex, 5/16-18 x 1
13	1923491	6	CAPSCREW, Hex, 7/16-14 x 1
14	1918199	3	LOCKWASHER, 7/16
15	1933263	3	WASHER, 7/16
16	1678665	3	PULLEY ASSY., Arbor Drive
17	1657969	3	SHIELD, Bearing Upper
18	1655729	3	ARBOR HOUSING, Top
19	108202	6	BEARING (Arbor Shaft)
20	1676277	3	SHAFT, Arbor
21	1676278	3	ARBOR SHAFT & BEARING ASSY. (Incl. Ref. Nos. 19 & 20)
22	1655728	3	ARBOR HOUSING, Bottom
23	1664847	18	SCREW, Hex, Tapitite, 5/16-18 x 3/4
24	1664241	3	WASHER, Shim
25	1657588	3	SHIELD, Grass
26	1655777	3	ADAPTOR, Blade
27	1657528	3	RING, Self Locking
28	1676343	3	BLADE, 60" Mower
29	1676287	3	WASHER, Spline
30	1656916	3	WASHER, Spring
31	1916950	1	NUT, Hex, 3/8-16
32	1917642	6	WASHER, 5/16
33	1674570	1	BELT, Arbor Drive
34	1676148	2	BUSHING
35	1674669	1	SPACER
36	915019	1	FITTING, Lube
37	1700395	1	LEVER ASSY., Idler
38	1923701	1	CAPSCREW, Hex, 3/8-16 x 2
39	1928731	1	LOCKNUT, Hex, Jam, 3/8-16
40	1679486	1	IDLER STOP
41	1916803	1	LOCKWASHER, Internal, 3/8
42	1674670	1	PULLEY, Idler
43	1928721	2	SETSCREW, Sq. Hd., 5/16-1/2
44	1674643	1	PULLEY ASSY., Drive
45	1960032	1	CAPSCREW, Hex, 3/8-16 x 1-1/4
46	1679487	1	ROD
47	1668500	1	BRACKET

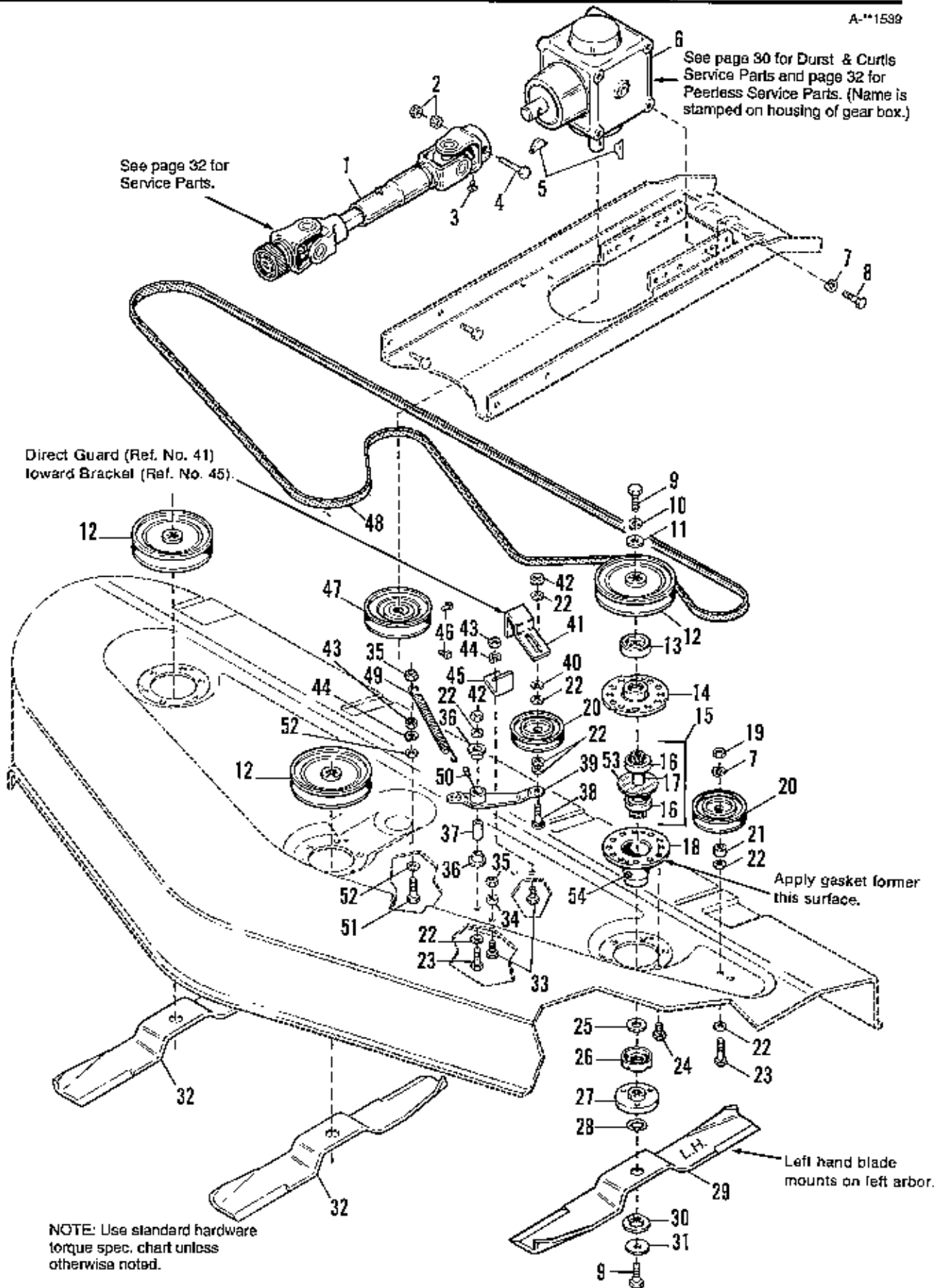

NOTE: Use standard hardware torque spec. chart unless otherwise noted.

## 60" Mower, Arbor &amp; Drive Group

Ref. No.	Part No.	Qty.	Description
1	1674213	1	DRIVE SHAFT ASSY., Telescoping (See page 32 for Service Parts.)
2	1923358	2	LOCKNUT, Hex, 1/4-20
3	1930543	1	SETSCREW, Hex, 5/16-18 x 1/2
4	1925688	1	CAPSCREW, Hex, 1/4-20 x 3
5	922138	2	KEY, Hi-Pro
* 6	1674642	1	RIGHT ANGLE GEAR CASE ASSY. (See page 30 for Durst & Curtis Service Parts & page 32 for Peerless Service Parts.)
7	1916965	5	LOCKWASHER, 5/8
8	1921965	4	CAPSCREW, Hex, 3/8-16 x 3/4
9	1923491	6	CAPSCREW, Hex, 7/16-14 x 1
10	1918199	3	LOCKWASHER, 7/16
11	1933263	3	WASHER, 7/16
12	1678665	3	PULLEY ASSY., Arbor Drive
13	1657969	3	SHIELD, Bearing, Upper
14	1655729	3	ARBOR HOUSING, Top
15	1676278	3	ARBOR SHAFT & BEARING ASSY.
16	108202	6	BEARING (Arbor Shaft)
17	1676277	3	SHAFT, Arbor
18	1703273	3	ARBOR HOUSING, Bottom
19	1916950	1	NUT, Hex, 3/8-16
20	1674670	2	PULLEY, Idler
21	157081	1	SPACER
22	1924940	10	WASHER, 13/32
23	1921971	2	CAPSCREW, Hex, 3/8-16 x 1-3/4
24	1664847	18	SCREW, Hex, Taptite, 5/16-18 x 3/4
25	1700230	3	WASHER, Shim
26	1700229	3	SHIELD, Grass
27	1655777	3	ADAPTOR, Blade
28	1657528	3	RING, Self-Locking
29	1702366	1	BLADE, 60" Mower, L.H. Rotation
30	1679711	3	WASHER, Splines
31	1656916	3	WASHER, Spring
32	1702365	2	BLADE, 60" Mower, R.H.
33	1921332	2	CAPSCREW, Hex, 5/16-18 x 3/4
34	1675481	1	SPACER
35	1923362	2	LOCKNUT, Hex, 5/16-18
36	1676148	2	BUSHING
37	1674669	1	SPACER
38	1960268	1	CARRIAGE BOLT, Hex, 3/8-16 x 1-1/4
39	1700395	1	LEVER ASSY., Idler
40	1916803	1	LOCKWASHER, Internal, 3/8
41	1679486	1	IDLER STOP
42	1928731	2	LOCKNUT, Hex, Jam, 3/8-16
43	1917372	2	NUT, Hex, 5/16-18
44	1917356	2	LOCKWASHER, 5/16
45	1668500	1	BRACKET
46	1928721	2	SETSCREW, Sq. Hd., 5/16-1/2
47	1674643	1	PULLEY ASSY., Drive
48	1700345	1	BELT, Arbor Drive
49	1700347	1	SPRING
50	915019	1	FITTING, Lube, 90
51	1921977	1	CAPSCREW, Hex, 5/16-18 x 1-3/4
52	1919326	2	WASHER, 11/32
53	1707335	3	GASKET, Foam
54	1704314	3	GREASE FITTING

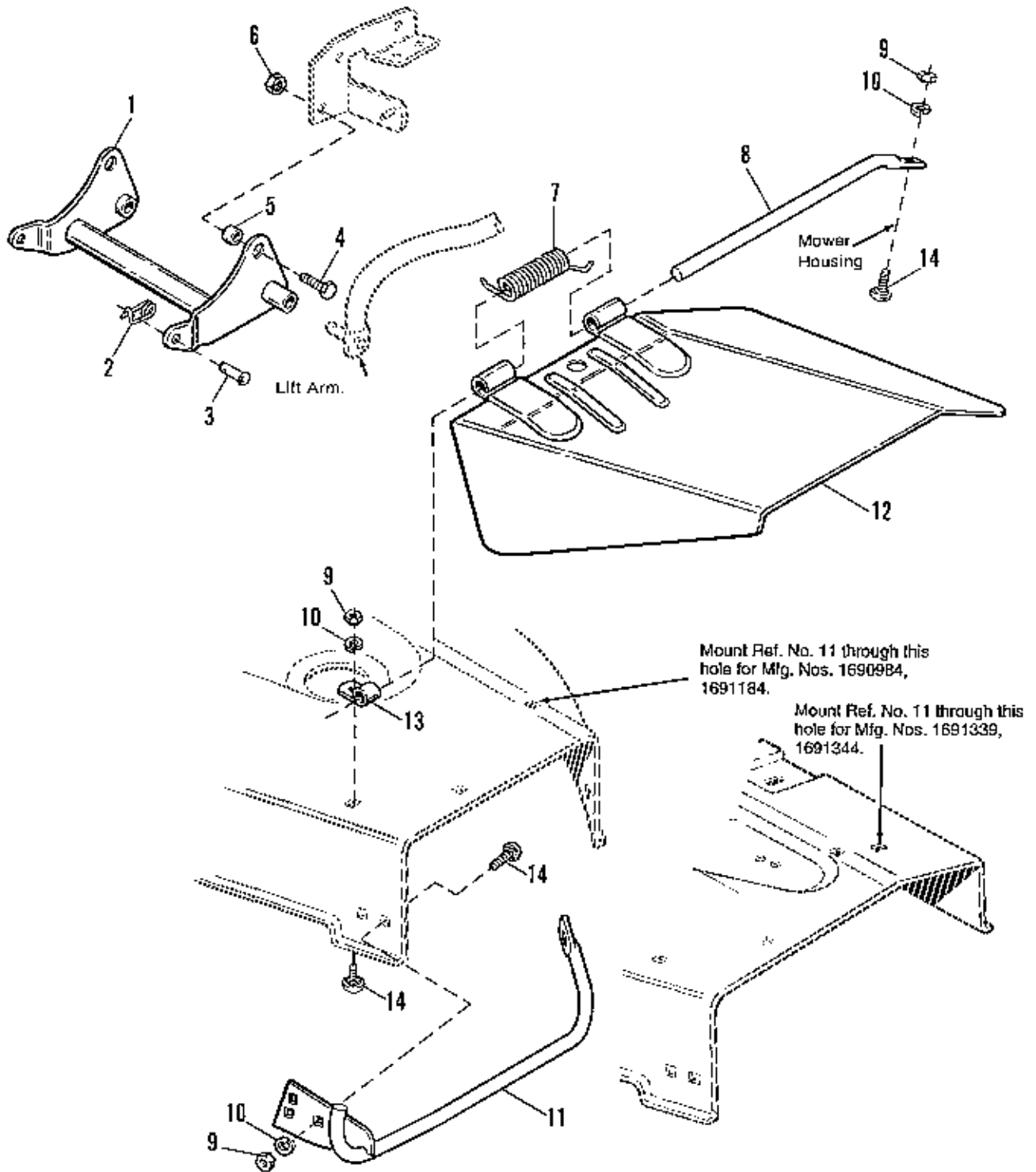

NOTE: Use standard hardware torque spec. chart unless otherwise noted.

## 60" Mower, Deflector Group

Ref. No.	Part No.	Qty.	Description
1	1674678	1	ARM ASSY., Rocker
2	176012	2	CLIP, Pin, Safety
3	156306	2	PIN, 3/8 x 1-1/2
4	1921176	2	CAPSCREW, Hex, 1/2-13 x 1-1/4
5	1676097	2	SPACER
6	1922134	2	NUT, Hex, Centerlock, 1/2-13
7	1676213	1	SPRING, Torsion
8	1673656	1	ROD, Hinge (1690984, 1691184 only)
	1700343	1	ROD, Hinge (1691339, 1691344 only)
9	1916950	3	NUT, Hex, 3/8-16
10	1916965	3	LOCKWASHER, 3/8
11	1677295	1	STONE GUARD ASSY. (1690984, 1691184 only)
	1700186	1	STONE GUARD ASSY. (1691339, 1691344 only)
12	1702451	1	DEFLECTOR ASSY.
13	1673655	1	BRACKET, Hinge
14	1931350	5	BOLT, Carriage, 3/8-16 x 1

NOTE: Arrows indicate top of Decal for positioning.

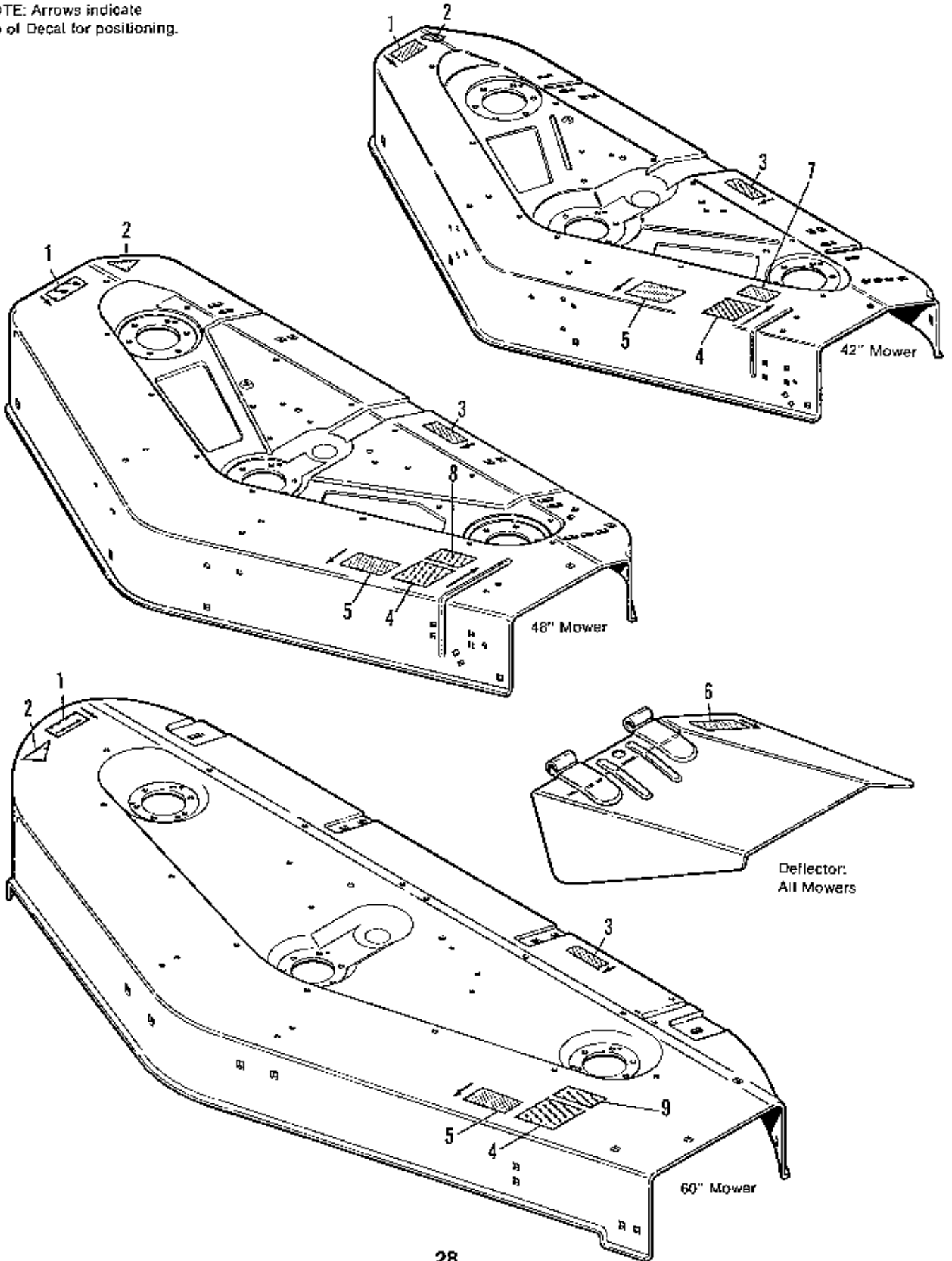

Ref. No.	Part No.	Qty.	Description
1	1676921	1	DECAL, Danger (1691184)
	1704276	1	DECAL, Danger (1691109, 1690986, 1691182, 1691183, 1691339, 1691344, )
2		1	DECAL, OPEI (Not Serviced)
3		1	I.D. PLATE (Not Serviced)
4	1676922	1	DECAL, Danger, Mower (1691184)
	1704277	1	DECAL, Danger, Mower (1691009, 1690986, 1691182, 1691183, 1691339, 1691344, )
5	1709069	1	DECAL, Belt Instruction (1691009, 1690984, 1690986, 1691182, 1691183, 1691184)
	1709068	1	DECAL, Belt Instruction (1691339, 1691344)
6	1664141	1	DECAL, Cutting Line
7	1704383	1	DECAL, Cutting width (42") (1691009)
8	1704384	1	DECAL, Cutting width (48") (1690986)
9	1704903	1	DECAL, Cutting width (60") (1691339)

Simplicity Mfg. Nos. 1690984 - 60" Mower  
 1690986 - 48" Mower  
 1691009 - 42" Mower  
 1691339 - 60" Mower

Agco Mfg. Nos. 1691182 - 42" Mower  
 1691183 - 48" Mower  
 1691344 - 60" Mower

Deutz Allis Mfg. No. 1691184 - 60" Mower

Safety Decals



16766921



1676922



1704276



1704277

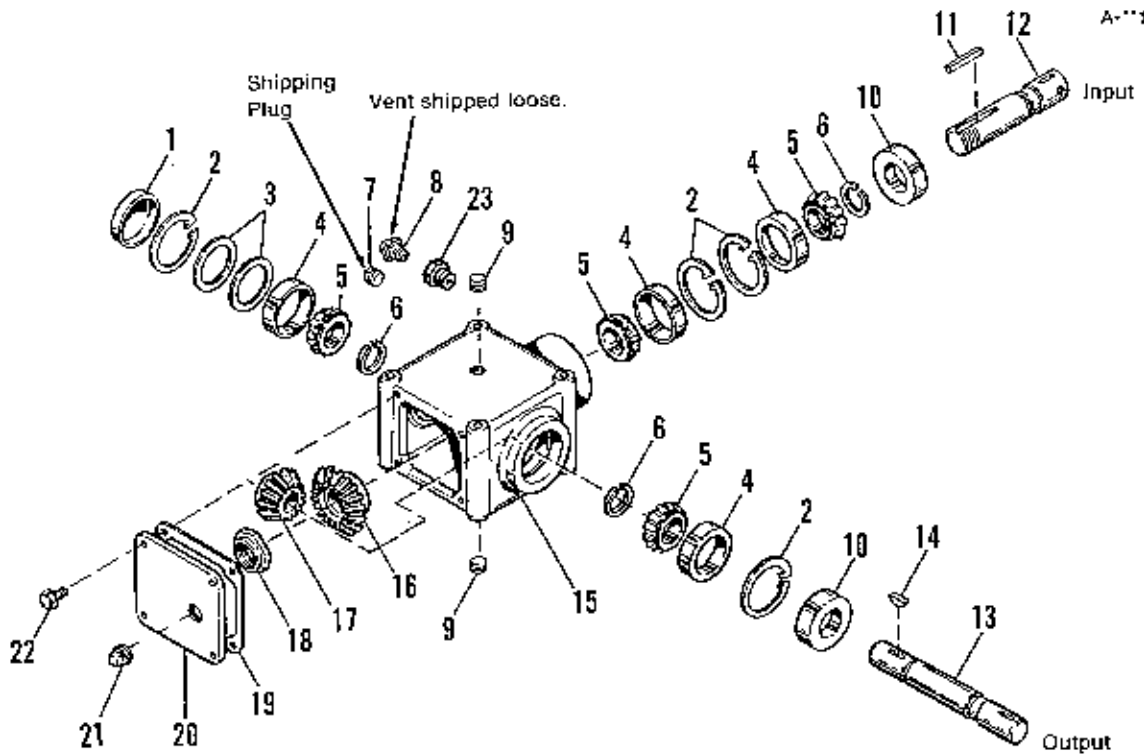
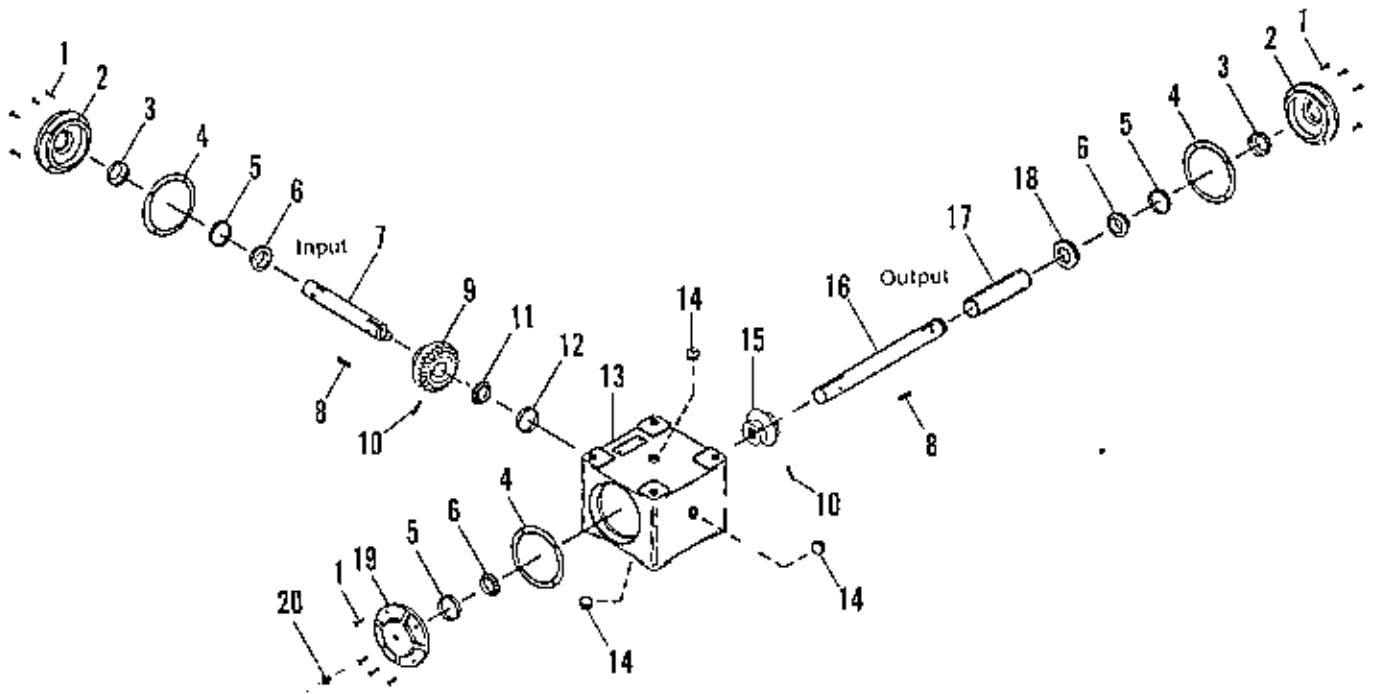



## 42", 48" &amp; 60" Mower, Drive Assy. (Curtis Gear Box)

Ref. No.	Part No.	Qty.	Description
1	1930591	12	SCREW, Hex Whizlock Flange, 5/16 x 3/4
2	1700894	2	CAP, Housing
3	118118	2	SEAL, Shaft, 1 x 1-1/2 x 5/16
4	* 1700895		GASKET, .015
	* 1700896		GASKET, .005
	* 1700897		GASKET, .003
5	170836	3	BEARING CUP
6	170835	3	BEARING, Cone
7	1700901	1	SHAFT, Pinion
8	1678932	2	KEY, 1/4 x 1/4 x 7/8
9	1700898	1	GEAR, Bevel
10	916796	2	ROLL PIN, 5/16 x 2
11	1700902	1	BEARING, Cone
12	1700903	1	BEARING CUP
13	1700889	1	HOUSING
14	901652	3	PLUG, Sq. Hd., Solid 1/4 NPT
15	1700905	1	GEAR, Pinion
16	1700890	1	SHAFT, Output
17	1700906	1	SPACER
18	1700907	1	WASHER
19	1700904	1	CAP, Housing
20	1678690	1	PLUG, Vent, 1/8-27

\*Use gaskets as required.

## 42", 48" &amp; 60" Mowers, Drive Assy. (Durst Gear Box)

Ref. No.	Part No.	Qty.	Description
1	173593	1	CAP, Bevel Gear Box
2	927700	4	SNAP RING
3	173598		SHIM, Bearing (Qty. as needed)
4	170836	4	CUP, Cone Bearing
5	170835	4	BEARING, Cone
6	1678907	3	SNAP RING
7	1668971	1	PLUG, 1/8-27 NPT
8	1678690	1	PLUG, Vent, 1/8-27 NPT
9	930674	2	PLUG, 3/8-18 NPT
10	1678912	2	SEAL
11	1678908	1	KEY, Sq., 1/4 x 1/4 x 3/4
12	1678910	1	SHAFT, Input
13	1678911	1	SHAFT, Output
14	905123	1	KEY, Woodruff, #9 (606) Hard
15	1678904	1	HOUSING, Bevel Gear
16	1678905	1	GEAR, Bevel, 24 Teeth
17	1678906	1	GEAR, Pinion, 16 Teeth
18	1678909	1	NUT, Stake, 1-18
19	173596	1	GASKET, Cover
20	1678903	1	COVER, Bevel Gear Box
21	901652	1	PLUG, Level, 1/4-18
22	1921332	4	CAPSCREW, 5/16-18 x 5/8
23	901825	1	REDUCER, 1/8-1/4



## Peerless Right Angle Drive Model 1100-012

Ref. No.	Part No.	Qty.	Description
1	770076		HOUSING, Right Angle Drive
2	786104A		CAP, Retainer
3	786117		CAP, Retainer
4	776221		SHAFT, Input
5	776222		SHAFT, Output
6	778169		GEAR, Bevel (27 Teeth)
7	778173		GEAR, Bevel (18 Teeth)
8	780131		SHIM, 1-1/2" OD x 1-1/64" ID x .002 Thick (Use as required.)
9	780138		SHIM, 2.000" OD x 1.531" ID x .002 thick (Use as required.)
10	780132		BEARING & CUP ASSY. (This assembly may have a shim washer included. The shim washer is not required at this location.)
11	780132		BEARING & CUP ASSY. (This is a factory sized assembly and may or may not include Ref. No. 8 Shim Washer. If Ref. No. 8 Shim Washer is supplied, it MUST be used in this location. All old Shim Washers MUST be discarded.)
12	780134		BEARING & CUP ASSY. (This is a factory sized assembly and may or may not include Ref. No. 9 Shim Washer. If Ref. No. 9 Shim Washer is included, it MUST be used in this location. All old Shim Washers MUST be discarded.)
14	788063		"O" RING
15	788064		SEAL, Oil
16	788065		SEAL, Oil
17	780136		SHIM, Cap Retainer
18	792037		SCREW, Hex Hd. Sems, 5/16-18 x 1
18A	792121		SCREW, Flat Socket Hd., 5/16-18 x 7/8
19	780137		RING, Load
20	792111		PLUG
22	792113		RING, Retaining
23	792110		JAM NUT, 3/4-16
24	792114		KEY, Woodruff
25	792115		WASHER, Flat
26	792116		PLUG, Pipe, 1/4-18
28	792039		PLUG, Pipe
29	792118		VALVE, Relief

See an authorized Tecumseh Dealer for parts & service. Peerless parts are not available through Simplicity.

Mfg. No. 1690984, 1690986, 1691009, 1691182, 1691183, 1691184, 1691339, 1691344

42", 48" & 60" Drive Shaft Group (Neapco - no marking on unit) (Weasler - name stamped on joint & shaft)

Ref. No.	Neapco Part No.	Weasler Part No.	Qty.	Description
1	1678806	1708309	1	REAR HALF ASSY., Drive Shaft (Incl. Ref. Nos. 2, 3 & 4)
2	1678807	178527	1	YOKE
3	1678805	1679003	2	JOURNAL ASSY. (Incl. Grease Fitting & E-Clips)
4	1703940	1708310	1	YOKE & TUBE ASSY.
5	1678799	1708307	1	FRONT HALF ASSY., Drive Shaft (Incl. Ref. Nos. 3 & 6 thru 11)
6	1703942	1708308	1	YOKE & SHAFT ASSY.
7	1678801	178530	1	YOKE ASSY. (Incl. Ref. Nos. 8 thru 11)
8	1702432		1	SPRING
9	1678802		1	SLIDE LOCK
10	1678804		2	BALL
11	1679531		1	SNAP RING
Not shown		1685480	1	SPRING-LOK KIT

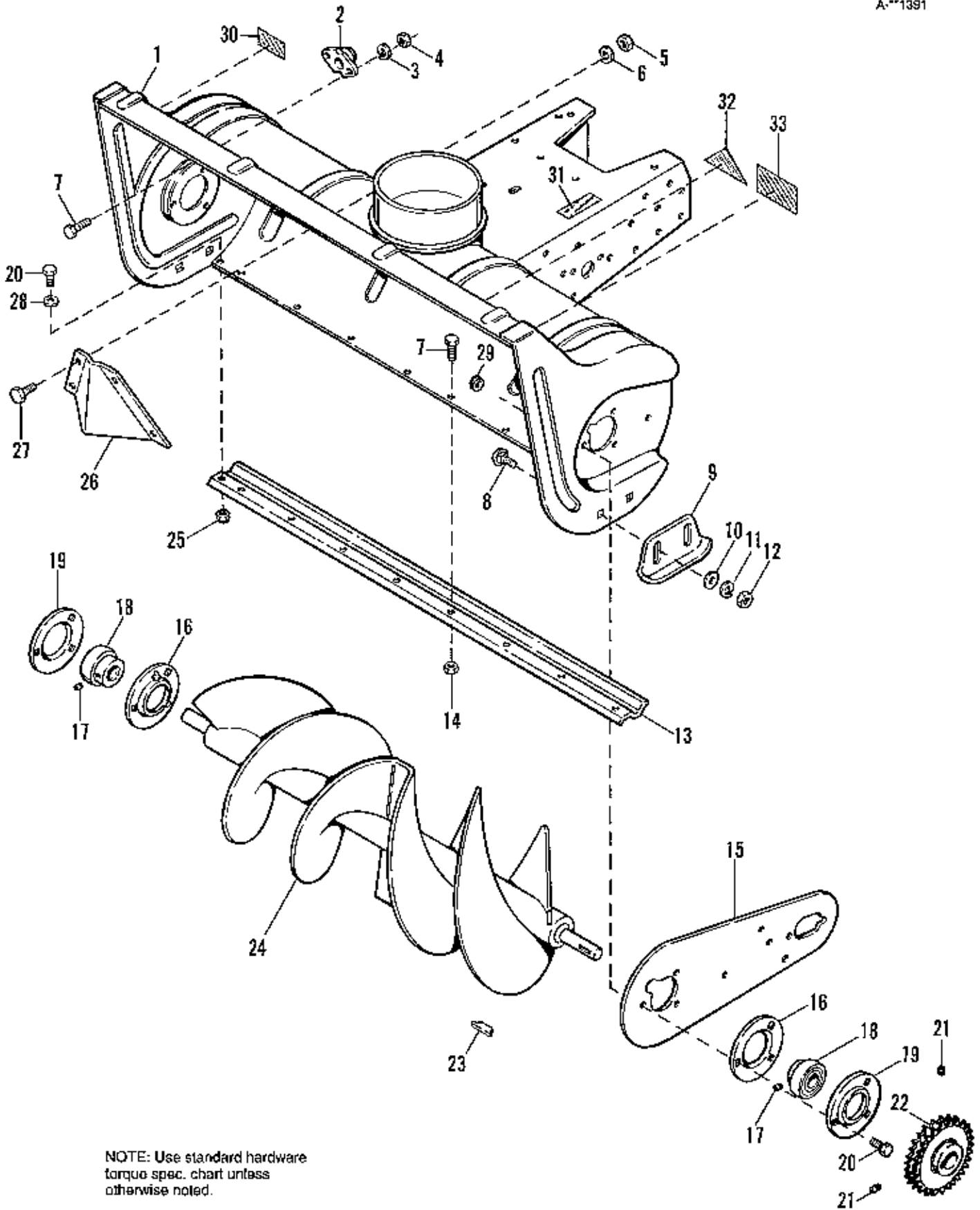

NOTE: Use standard hardware torque spec. chart unless otherwise noted.

Ref. No.	Part No.	Qty.	Description
1	1676059	1	BODY & FRAME ASSY.
2	171388	1	BEARING, Body Mounted
3	916964	2	LOCKWASHER, 1/4 Std.
4	1916622	2	NUT, Hex, 1/4-20
5	1917372	4	NUT, Hex, 5/16-18
6	1917356	4	LOCKWASHER, 5/16 Std.
7	1921959	10	CAPSCREW, Hex Hd., 1/4-20 x 5/8
8	922110	4	BOLT, Carriage, 3/8-16 x 3/4
9	177434	2	SKID SHOE
10	1924940	4	WASHER, 3/8 Std.
11	1916965	4	LOCKWASHER, 3/8
12	1916950	4	NUT, Hex, 3/8-16
13	106746	1	SCRAPER BAR
14	1923358	8	NUT, Hex, Lock, 1/4-20
15	1676632	1	PLATE, Side
16	172279	2	FLANGE, Bearing
17	1960110	2	SETSCREW, Hex Hd., 1/4-28 x 1/2
18	173934	2	BEARING, Cartridge, Auger
19	172278	2	FLANGE, Bearing
20	1921332	8	CAPSCREW, Hex Hd., 5/16-18 x 3/4
21	1677029	2	SETSCREW, 5/16-18
22	1676721	1	DOUBLE SPROCKET ASSY., 29 Teeth
23	151040	1	KEY
24	106748	1	ROTOR ASSY.
25	1923362	2	NUT, Hex, Lock, 5/16-18
26	106774	1	DEFLECTOR
27	1925205	4	CAPSCREW, Hex Hd., 5/16-18 x 5/8
28	1919326	2	WASHER, 1/4 Std.
29	1935048	6	NUT, Flangelock, 2 way, 5/16-18
<b>Decals</b>			
30	1679206	1	DECAL, Caution
31			DECAL, I.D. Plate (Not Serviced)
32			DECAL, OPEI (Not Serviced)
33	1677485	1	DECAL, Danger, Auger

## Safety Decals



Ref No. 30



Ref No. 33

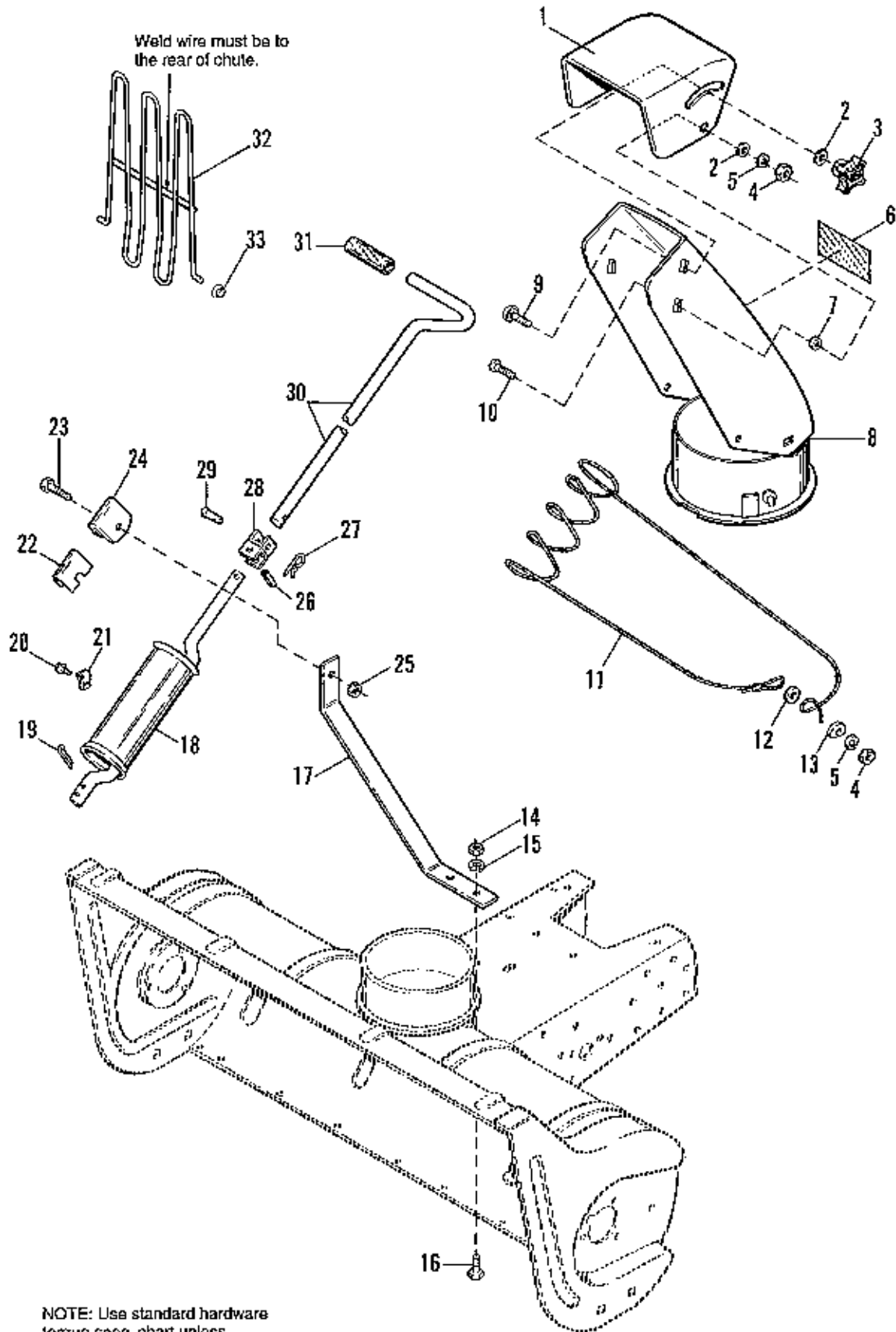

NOTE: Use standard hardware torque spec. chart unless otherwise noted.

Ref. No.	Part No.	Qty.	Description
1	1667791	1	DEFLECTOR
2	1919326	3	WASHER, 11/32 Std.
3	1670578	1	KNOB
4	1917372	3	NUT, Hex, 5/16-18
5	1917356	3	WASHER, Spring Lock, 5/16
6	1677488	1	DECAL, Danger, Blower
7	1667790	2	SPACER
8	1704294	1	CHUTE ASSY.
9	1931335	1	BOLT, Carriage, 5/16-18 x 1
10	1936482	2	SCREW, Truss, Phil. Hd., 5/16-18 x 3/4
11	171362	1	CABLE ASSY.
12	1919326	1	WASHER, 5/16 Std.
13	171379	1	WASHER, Cup
14	1916950	2	NUT, Hex, 3/8-16
15	1916965	2	LOCKWASHER, 3/8 Std.
16	1921210	2	CAPSCREW, Hex Hd., 3/8-16 x 1
17	1679013	1	BRACE, Handle
18	1676885	1	SPOUT CONTROL ASSY.
19	1918447	2	PIN, Cotter, 3/32 x 3/4
20	1927428	1	SCREW, Hex, Taplite, 1/4 x 3/8
21	171382	1	CLAMP
22	121175	1	LINER
23	1921221	1	CAPSCREW, Hex Hd, 5/16-18 x 1-1/2
24	152050	1	ROD GUIDE
25	1923362	1	NUT, Hex, Lock, 5/16-18
26	916169	1	PIN, Spring, 3/16 x 3/4
27	1960221	1	PIN, Hair
28	1676817	1	"U" JOINT ASSY.
29	1676883	1	PIN
30	1676880	1	HANDLE, Pivot
31	176933	1	GRIP, Handle
32	1704446	1	GUARD ASSY., Chute
33	1960126	2	PUSH NUT

## Safety Decal



Ref No. 6

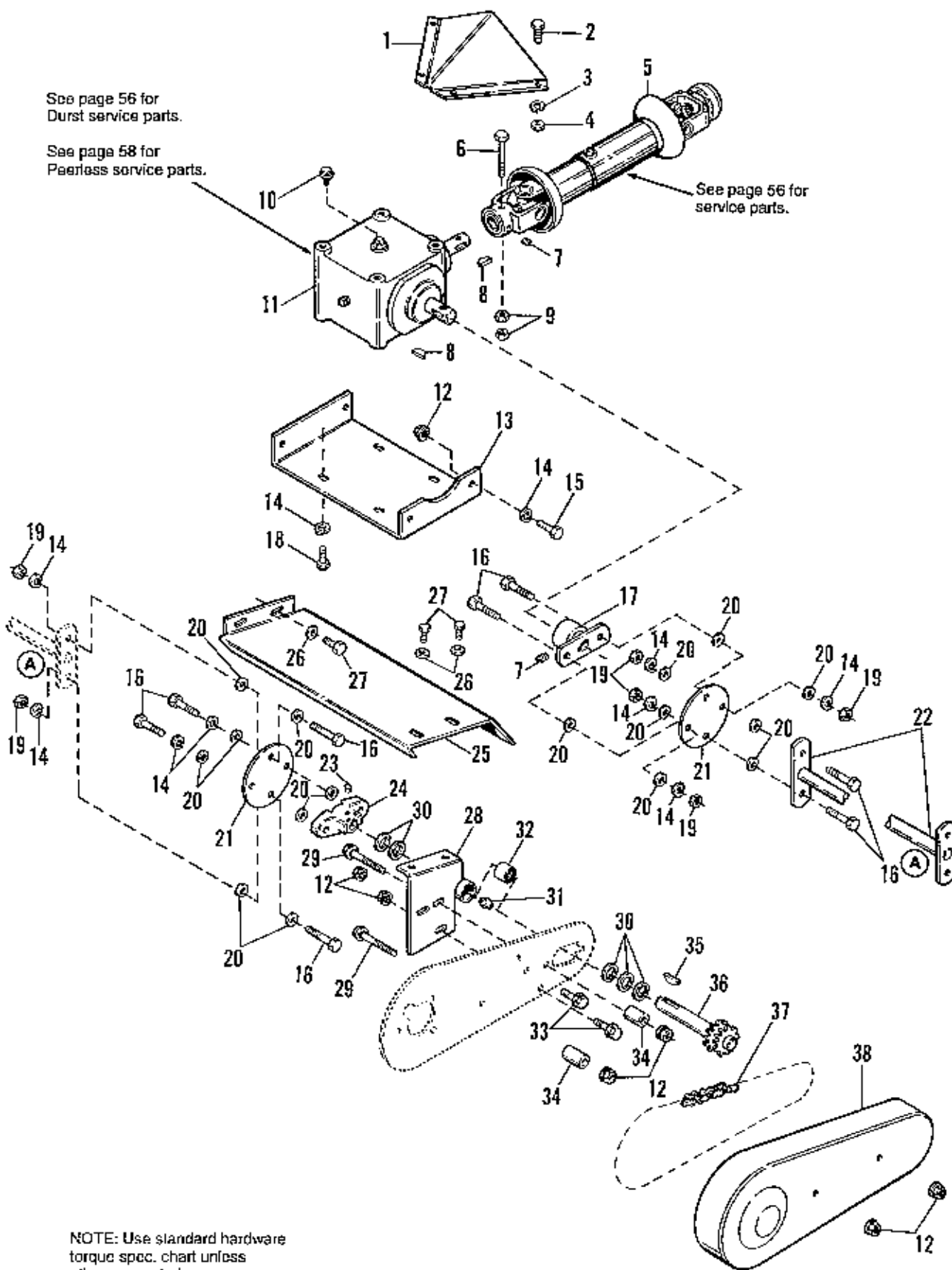



## 42" Snowthrower, Drive Group

Ref. No.	Part No.	Qty.	Description
1	106774	1	DEFLECTOR
2	1925205	4	CAPSCREW, Hex Hd., 5/16-18 x 5/8
3	1917356	4	LOCKWASHER, Spring, 5/16
4	1917372	4	NUT, Hex, 5/16-18, NC - 2B
5	1675387	1	DRIVE SHAFT ASSY. (See page 56 for Service Parts)
6	1925688	1	CAPSCREW, Hex Hd., 1/4-20 x 3
7	1930540	2	SETSCREW, Sq. Hd., 5/16-18 x 5/8
8	922138	2	KEY, Hi-Pro #HP708
9	1923358	2	NUT, Hex, Lock, 1/4-20
10	1678690	1	PLUG, Vent, 1/8-27 NPT
11	1676047	1	DRIVE ASSY., Right Angle (Incl. Ref. No. 10) (See page 56 for Durst Service Parts & page 58 for Peerless Service Parts.)
12	1926352	10	NUT, Hex, Flange, Whizlock, 3/8-16
13	1676053	1	BRACKET, Mounting (for Drive Assy.)
14	1916965	16	LOCKWASHER, 3/8 Std.
15	1921966	4	CAPSCREW, Hex Hd., 3/8-16 x 7/8
16	1920415	8	CAPSCREW, Hex Hd., 3/8-16 x 1-1/4
17	1676561	1	COUPLER ASSY., - Drive
18	1921965	4	CAPSCREW, 3/8-16 x 3/4
19	1916950	6	NUT, Hex, 3/8-16
20	157424	16	WASHER, Special
21	173026	2	COUPLING
22	1676559	1	SHAFT ASSY., Drive
23	924624	1	SETSCREW, 3/8-24 x 3/8
24	154198	1	FLANGE, Drive Shaft
25	1676623	1	COVER ASSY., Drive Shaft
26	1919326	4	WASHER, 5/16, Std.
27	1924856	4	SCREW, Hex, Taptite, 5/16-18 x 1/2
28	1676554	1	SUPPORT ASSY., w/Bearings (Incl. Ref. No. 32)
29	1960244	2	CAPSCREW, Hex, Whizlock, 3/8-16 x 2-3/4
30	168111	5	WASHER, Hardened
31	921133	1	FITTING, Grease
32	1679211	2	BEARING, Needle
33	1934654	2	SCREW, Hex, Whizlock, 3/8-16 x 1
34	1669105	2	SPACER
35	905123	1	KEY, Woodruff #9
36	1676722	1	SHAFT ASSY., (Drive, Chain)
37	1676739	1	CHAIN, Roller
38	1676738	1	GUARD, Chain

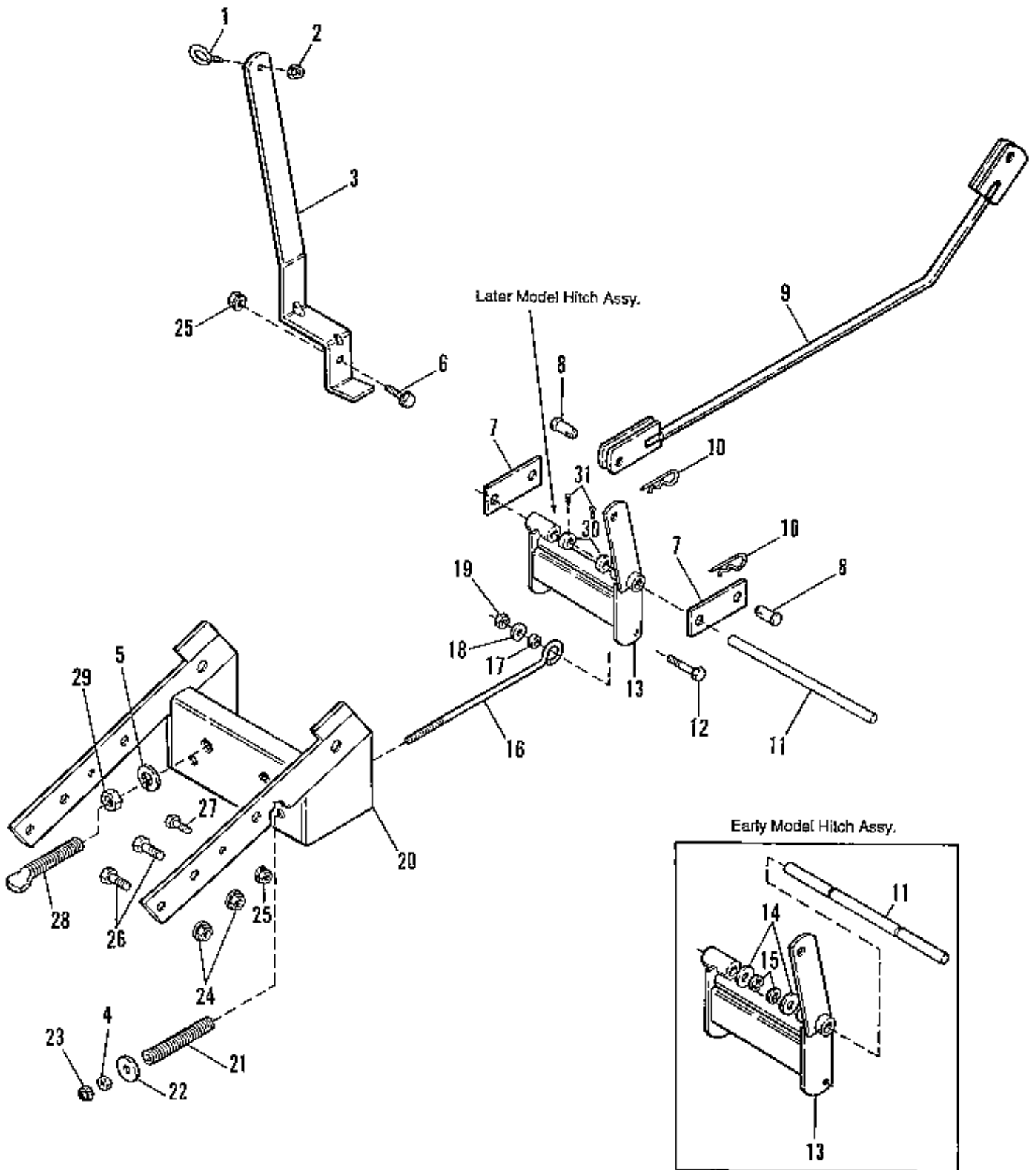

NOTE: Use standard hardware torque spec. chart unless otherwise noted.

## 42" Snowthrower, Hitch Group

Ref. No.	Part No.	Qty.	Description
1	172162	1	EYEBOLT
2	1923358	1	NUT, Hex, Lock, 1/4-20
3	1676912	1	SUPPORT, Control Rod
4	1916950	3	NUT, Hex, 3/8-16
5	1919332	2	LOCKWASHER, 3/4 Std.
6	1928727	1	SCREW, Hex, Flange Whizlock, 3/8-16 x 1-1/4
7	1675525	2	LINK
8	1960038	4	PIN, Clevis
9	1675390	1	LIFT ROD ASSY.
10	1960033	4	CLIP, Spring
11	* 1685484	1	SHAFT, Inner
	** 1708999	1	SHAFT, Inner
12	1922664	2	CAPSCREW, Hex Hd., 5/8-11 x 2
13	1675502	1	HITCH ASSY.
14	* 1919387	2	WASHER, Plain, 41/64 x 1-1/4 x 1/16
15	* 927793	2	RING, Retaining "E", 5/8
16	1675523	2	EYEBOLT
17	175647	2	SPACER
18	933757	2	WASHER, Plain, 41/64 x 1-3/4 x 1/8
19	1923353	2	NUT, Hex, Centerlock, 5/8-11
20	1703635	1	HITCH ASSY., Blower
21	1675524	2	SPRING, Compression
22	1960071	2	WASHER, 13/32 x 1-1/4 x 1/4
23	1917421	2	NUT, Jam, Hex, 3/8-16
24	1935041	4	NUT, Hex, Flange, Whizlock, 7/16-14
25	1928352	2	NUT, Hex, Flange, Whizlock, 3/8-16
26	1920676	4	CAPSCREW, Hex Hd., 7/16-14 x 1
27	1921210	2	CAPSCREW, Hex Hd., 3/8-16 x 1
28	1676959	2	STUD
29	1913160	2	NUT, Hex, 3/4-10
30	** 8031007	2	SET-COLLAR
31	** 1928721	2	SET- SCREW, Sq. Hd. cup point, 5/16-18 x 1/2

**NOT SHOWN: Hydraulic Oil Flow Restrictor Kit, Part No. 1685300**

\* Early Models (see art page)

\*\* Later Models (see art page)

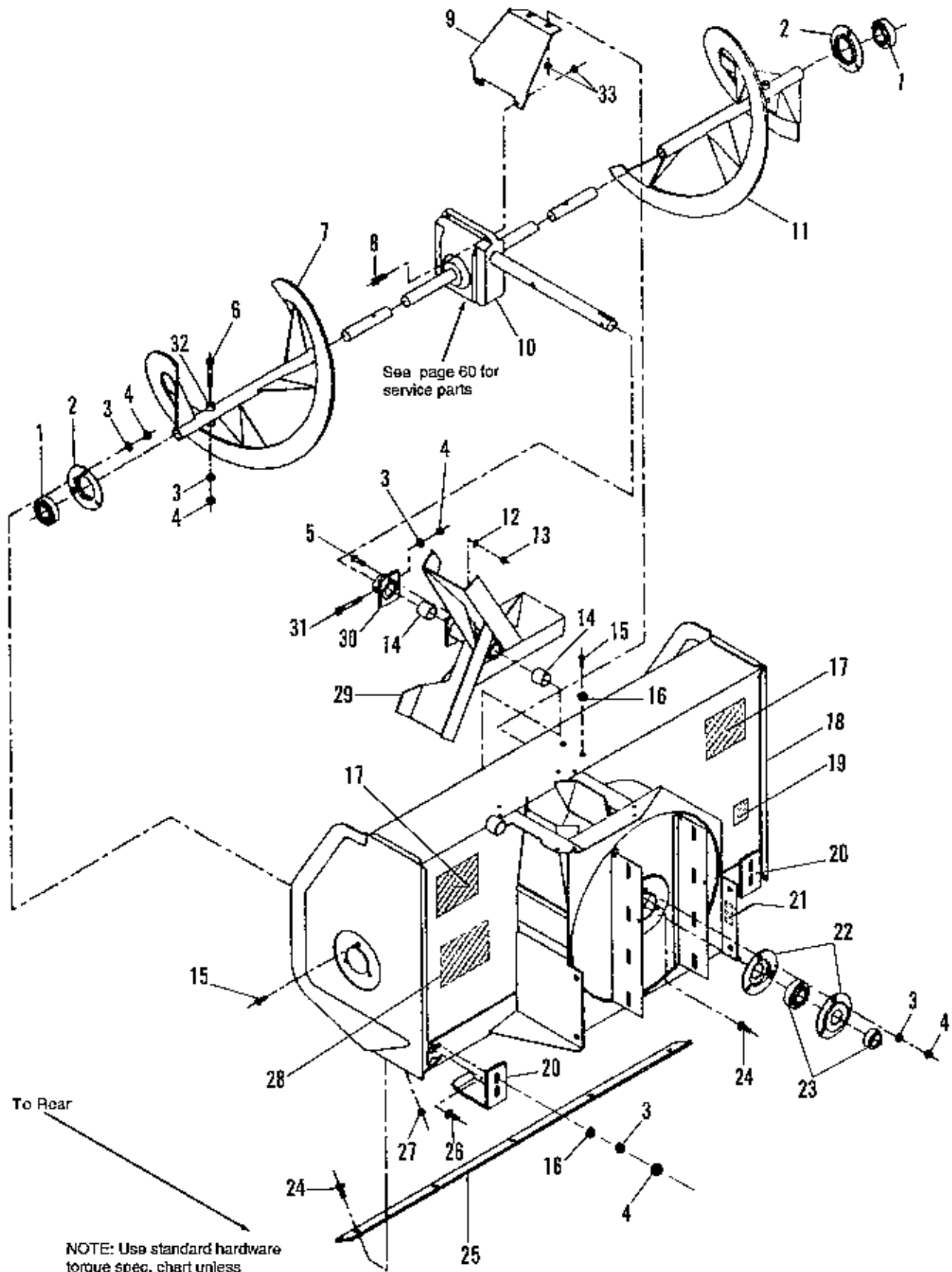

## 46" Snowthrower, Body &amp; Rotor Group

Ref. No.	Part No.	Qty.	Description
1	1701045	2	BEARING, w/Locking Screw
2	1701046	2	FLANGE, Bearing (Cover)
3	1917356	18	LOCKWASHER, 5/16
4	1917372	18	NUT, Hex, 5/16-18
5	1921961	1	BOLT, Shear, 1/4-20 x 1-1/4, Gr. 5
6	1700680	2	SHEAR BOLT, 5/16-18 x 2-1/4
7	1701042	1	AUGER ASSY., L.H.
8	1921977	2	CAPSCREW, Hex Hd., 5/16-18 x 1-1/4
9	1701047	1	BRACKET, Support (Worm Gear)
10	* 1701037	1	GEAR ASSY., Worm (Clockwise)(See page 60 for Service Parts.)
	** 1707748	1	GEAR ASSY., Worm (Clockwise)(See page 60 for Service Parts.)
11	1701044	1	AUGER ASSY., R.H.
12	1916964	1	LOCKWASHER
13	1916622	1	NUT, Hex, 1/4-20
14	168103	2	BUSHING, 1" O.D. x 1-1/8" O.D. x 1"
15	1921332	8	CAPSCREW, Hex Hd., 5/16-18 x 3/4
16	1918266	6	WASHER, Plain, S.A.E. 3/8
17	1701067	2	DECAL, Danger (Rotating Auger)
18	1701036	1	FRAME ASSY.
19	1701043	1	DECAL, Lube, Chain
20	1701051	2	SHOE, Skid
21	1701141	1	DECAL, Oil Level
22	172278	2	FLANGE, Bearing ( Cover)
23	173934	1	BEARING, w/Locking Collar
24	1931333	9	BOLT, Carriage, 5/16-18 x 3/4
25	1701050	1	EDGE, Cutting
26	1931335	4	BOLT, Carriage, 5/16-18 x 1
27	1928698	6	NUT, Hex Fin. Jam, 5/16-18 (Center or Top Lock)
28	1701142	1	DECAL, Shear Bolts
29	1701038	1	FAN ASSY.
30	1701040	1	ADAPTOR, Fan Shear Plate
31	1921978	1	CAPSCREW, Hex Hd., 5/16-18 x 2
32	1701052	4	BUSHING, Shear Bolt
33	1919438	2	NUT, Hex, ESNA, 5/16-18

\* Used on Mfg. No. 1671360 Before Serial No. 00309.

\*\* Used on Mfg. No. 1671360 After Serial No. 00308.

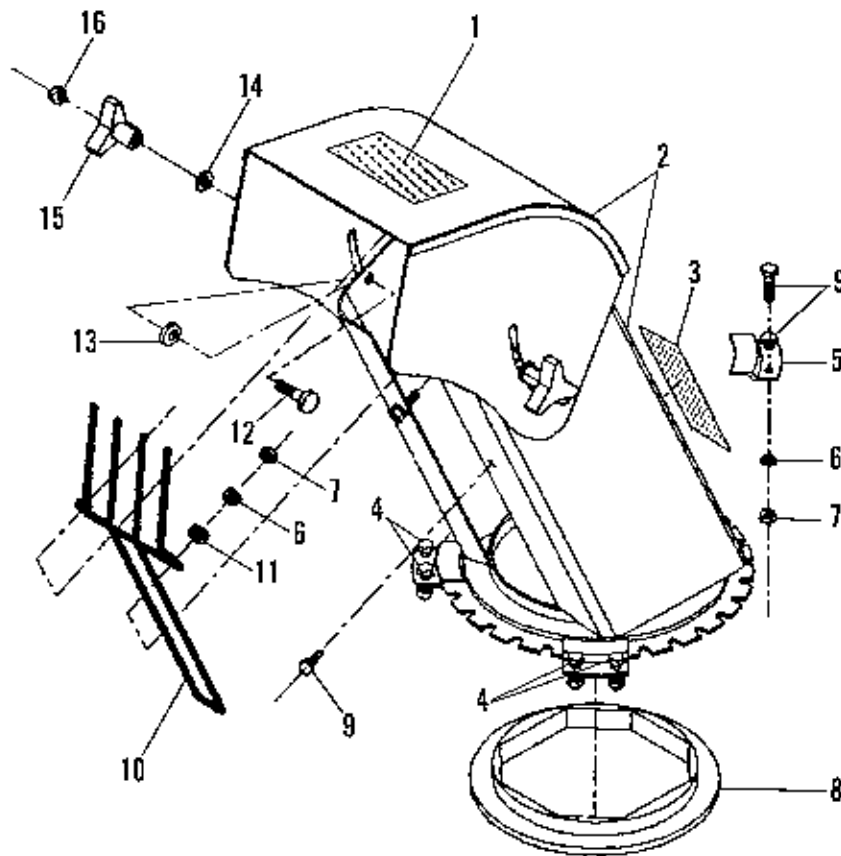

NOTE: Use standard hardware torque spec. chart unless otherwise noted.

## 46" Snowthrower, Spout Group

Ref. No.	Part No.	Qty.	Description
1	1701102	1	DECAL, Danger (Discharge Chute)
2	1701068	1	CHUTE & DEFLECTOR ASSY. w/Knobs & Decals (Incl. Ref. Nos. 1, 3 & 12 - 16.)
3	1701101	1	DECAL, Warning (Safe Operation)
4	1921958	6	CAPSCREW, Hex Hd., 1/4-20 x 1/2
5	1701071	4	PLATE, Retaining
6	1916964	10	LOCKWASHER, 1/4
7	1916622	10	NUT, Hex, 1/4-20
8	1701072	1	RING, Nylon
9	1923341	4	CAPSCREW, Hex Hd., 1/4-20 x 3/4
10	1701070	1	GUARD, Stone
11	1918265	2	WASHER, Plain, S.A.E. 5/16
12	1960223	2	BOLT, Carriage, 5/16-18 x 1-1/4
13	918267	2	WASHER, Plain, S.A.E. 7/16
14	1918266	2	WASHER, Plain, S.A.E. 3/8
15	1670578	2	KNOB
16	1923362	2	NUT, Hex Centerlock, 5/16-18

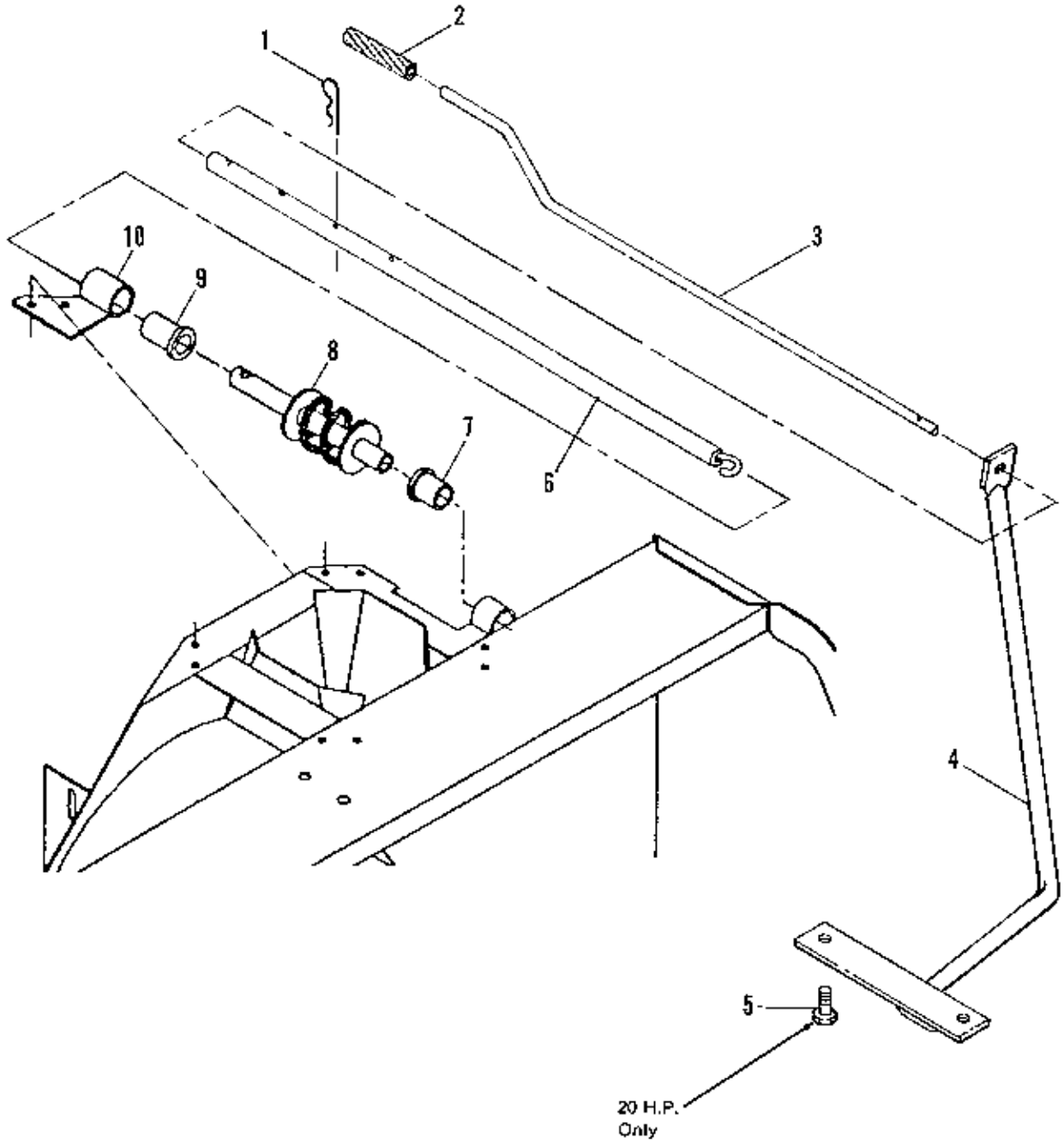

NOTE: Use standard hardware torque spec. chart unless otherwise noted.



46" Snowthrower, Spout Rotator Group

---

Ref. No.	Part No.	Qty.	Description
1	1960033	1	CLIP, Hair Pin, 1/8 x 2-9/16
2	1701079	1	GRIP, Handle (Rubber)
3	1706021	1	HANDLE
4	1701103	1	SUPPORT ASSY., Spout Rotator
5	1921212	1	CAPSCREW, Hex Hd., 5/16-14 x 1-1/2, Gr. 5
6	1706020	1	TUBE, Upper Rotation
7	1701073	1	BUSHING, Plastic w/Flange
8	1701074	1	WORM, Rotation
9	1701075	1	BUSHING, Plastic w/Flange
10	1701076	1	SUPPORT, Rotation, Worm

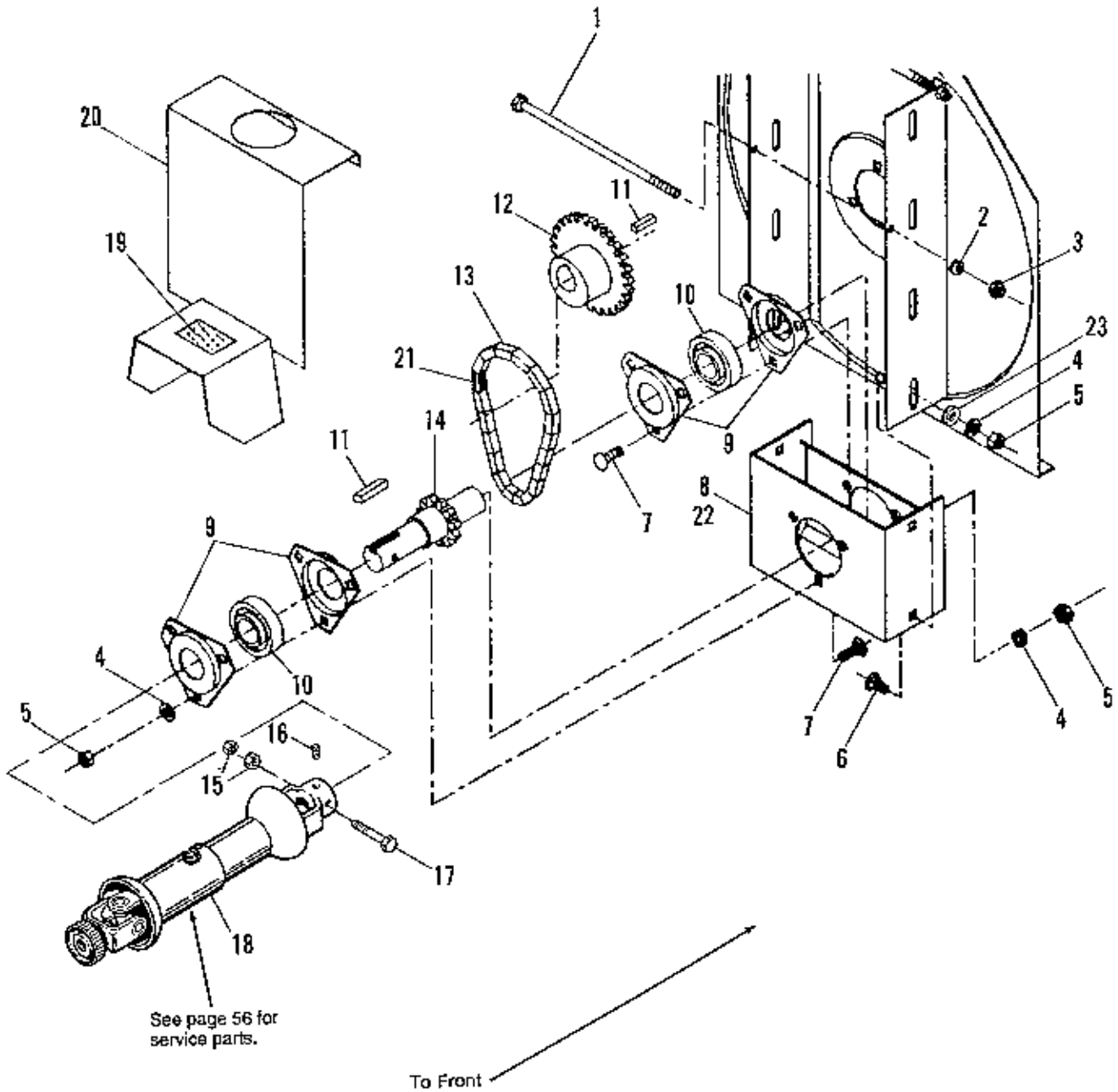

NOTE: Use standard hardware torque spec. chart unless otherwise noted.

## 46" Snowthrower, Drive Group

Ref. No.	Part No.	Qty.	Description
1	936288	2	CAPSCREW, Hex Hd., 1/4-20 x 7-1/2
2	1916964	2	LOCKWASHER, 1/4
3	1916622	2	NUT, Hex, 1/4-20
4	1917356	10	LOCKWASHER, 5/16
5	1917372	10	NUT, Hex, 5/16-18
6	1960282	4	BOLT, Carriage, 5/16-18 x 3/4
7	1920561	6	BOLT, Carriage, 5/16-18 x 5/8
8	1701080	1	BOX ASSY., Reduction (Incl. Ref. Nos. 4 & 5, Qty. 6; 7, 8, 9, 10, 14 & 22.)
9	1701083	4	BEARING, Flange
10	1701045	2	BEARING, 1" I.D. w/Locking Screw
11	154096	2	KEY, Parallel, Plain, 1/4 x 1/4 x 1-1/4
12	1701084	1	SPROCKET
13	1701085	1	CHAIN
14	1701082	1	SHAFT, Assy., Drive, w/Sprocket
15	1923358	2	NUT, Hex Lock, 1/4-20
16	1930540	1	SETSCREW, Sq. Hd., 5/16-18 x 5/8
17	1925688	1	CAPSCREW, Hex Hd., 1/4-20 x 2-1/2
18	1675387	1	DRIVE SHAFT (See page 56 for Service Parts)
19	1679461	1	DECAL, Danger
20	1701086	1	SHIELD, P.T.O.
21	1701260	1	LINK, Connecting, Chain
22	1701081	1	BOX, Reduction
23	1919381	4	WASHER

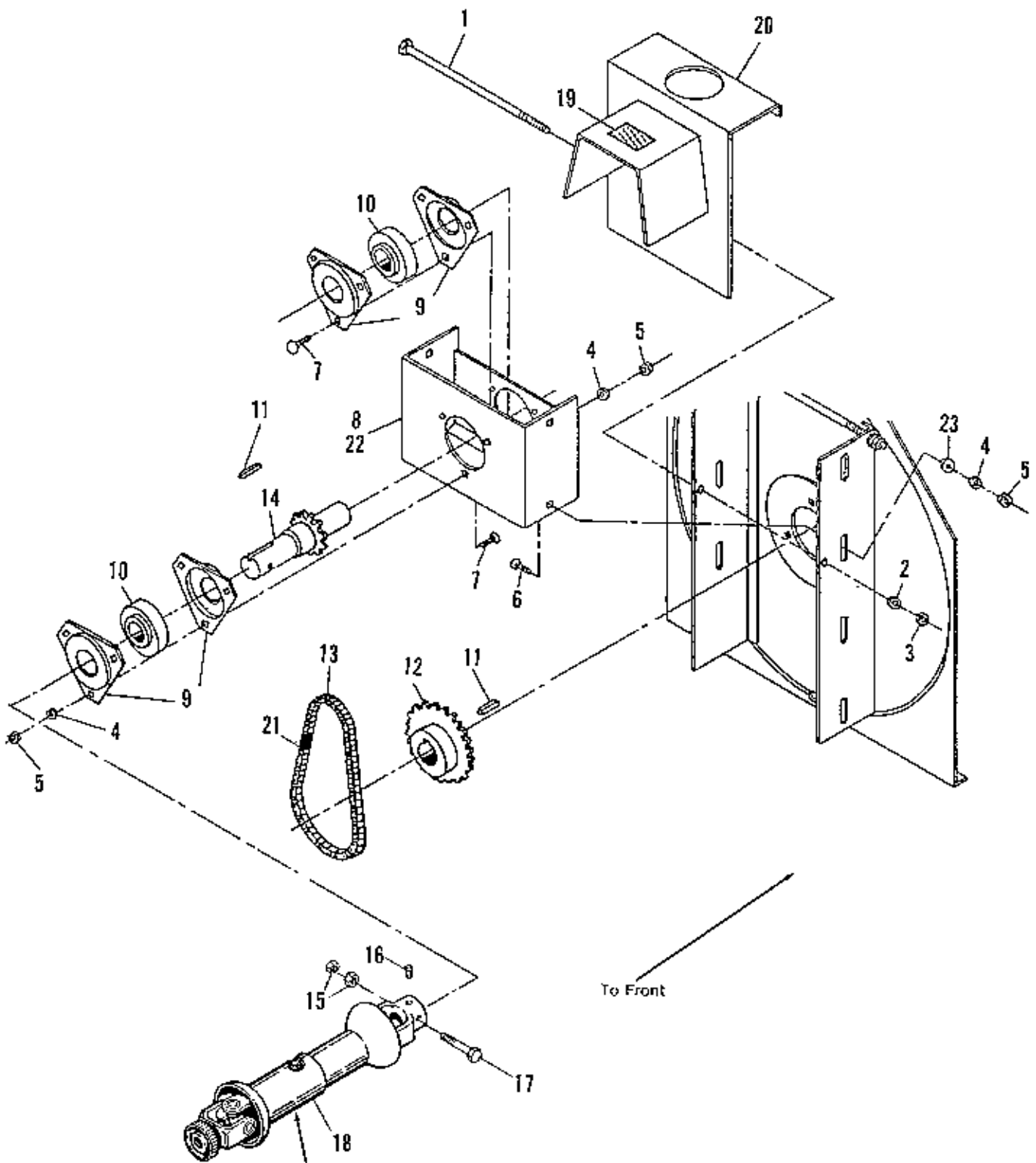

See page 56 for service parts.

NOTE: Use standard hardware torque spec. chart unless otherwise noted.

## 46" Snowthrower, Drive Group

Ref. No.	Part No.	Qty.	Description
1	936288	2	CAPSCREW, Hex Hd., 1/4-20 x 7-1/2
2	1916964	2	LOCKWASHER, 1/4
3	1916622	2	NUT, Hex, 1/4-20
4	1917356	10	LOCKWASHER, 5/16
5	1917372	10	NUT, Hex, 5/16-18
6	1960282	4	BOLT, Carriage, 5/16-18 x 3/4
7	1920561	6	BOLT, Carriage, 5/16-18 x 5/8
8	1701080	1	BOX ASSY., Reduction (Incl. Ref. Nos. 4 & 5, Qty. 6; 7, 8, 9, 10, 14 & 22.)
9	1701083	4	BEARING, Flange
10	1701045	2	BEARING, 1" I.D. w/Locking Screw
11	157652	2	KEY, Parallel, Plain, 1/4 x 1/4 x 1-1/4
12	1701084	1	SPROCKET
13	1701085	1	CHAIN
14	1701082	1	SHAFT, Assy., Drive, w/Sprocket
15	1923358	2	NUT, Hex Lock, 1/4-20
16	1930540	1	SETSCREW, Sq. Hd., 5/16-18 x 5/8
17	1925688	1	CAPSCREW, Hex Hd., 1/4-20 x 2-1/2
18	1675387	1	DRIVE SHAFT (See page 56 for Service Parts)
19	1679461	1	DECAL, Danger
20	1704160	1	SHIELD, P.T.O.
21	1701260	1	LINK, Connecting, Chain
22	1701081	1	BOX, Reduction
23	1919381	4	WASHER

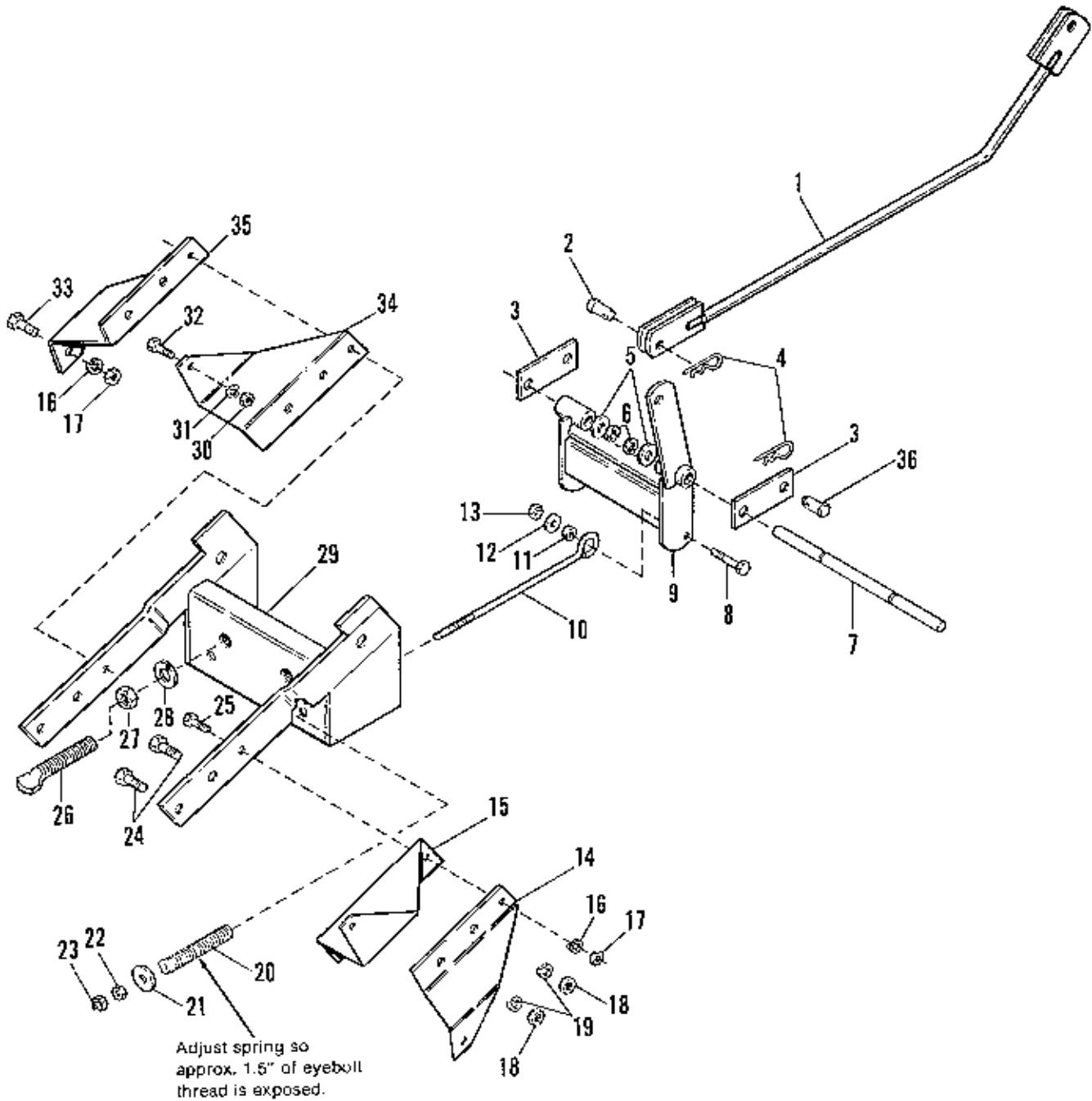

NOTE: Use standard hardware torque spec. chart unless otherwise noted.

## 46" Snowthrower, Hitch Group

Ref. No.	Part No.	Qty.	Description
1	1675390	1	LIFT ROD ASSY.
2	1960038	2	PIN, Clevis
3	1675525	2	LINK
4	1960033	4	CLIP, Hair Pin
5	1919387	2	WASHER, Plain, 41/64 x 1-1/4
6	927793	2	RING, Retaining, 5/8
7	1676350	1	SHAFT, Inner
8	1922664	2	CAPSCREW, Hex Hd., 5/8-11 x 2
9	1675502	1	HITCH ASSY.
10	1675523	2	EYEBOLT
11	175647	2	SPACER
12	933757	2	WASHER, Plain, 41/64 x 1-3/4
13	1923353	2	NUT, Hex, Centerlock, 5/8-11
14	1701104	1	BRACKET, Attaching, L.H., Lower
15	1701041	1	BRACKET, Attaching, L.H., Upper
16	1916965	4	LOCKWASHER, 3/8
17	1916950	4	NUT, 3/8-16
18	1918213	4	NUT, 7/16-14
19	1918199	4	LOCKWASHER, 7/16
20	1675524	2	SPRING, Compression
21	1960071	2	WASHER, 3/8 x 1-3/4 x 1/4
22	1916950	2	NUT, Hex, 3/8-16
23	1917421	2	NUT, Hex, Jam, 3/8-16
24	1920677	4	CAPSCREW, 7/16-14 x 1-1/4
25	1920415	2	CAPSCREW, 3/8-16 x 1-1/4
26	1676959	2	STUD
27	1913160	2	NUT, Hex, 3/4-10
28	1919332	2	LOCKWASHER, 3/4 Std.
29	1676389	1	HITCH ASSY., Blower
30	1916951	2	NUT, 1/2-13
31	1916966	2	LOCKWASHER, 1/2
32	1923114	2	CAPSCREW, Hex Hd., 1/2-13 x 1
33	1921210	2	CAPSCREW, Hex Hd., 3/8-16 x 1
34	1701105	1	BRACKET, Attaching, R.H., Upper
35	1701106	1	BRACKET, Attaching, R.H., Lower
36	1703683	2	PIN ASSY. (Flat Head)

**NOT SHOWN: Hydraulic Oil Flow Restrictor Kit, Part No. 1685300.**

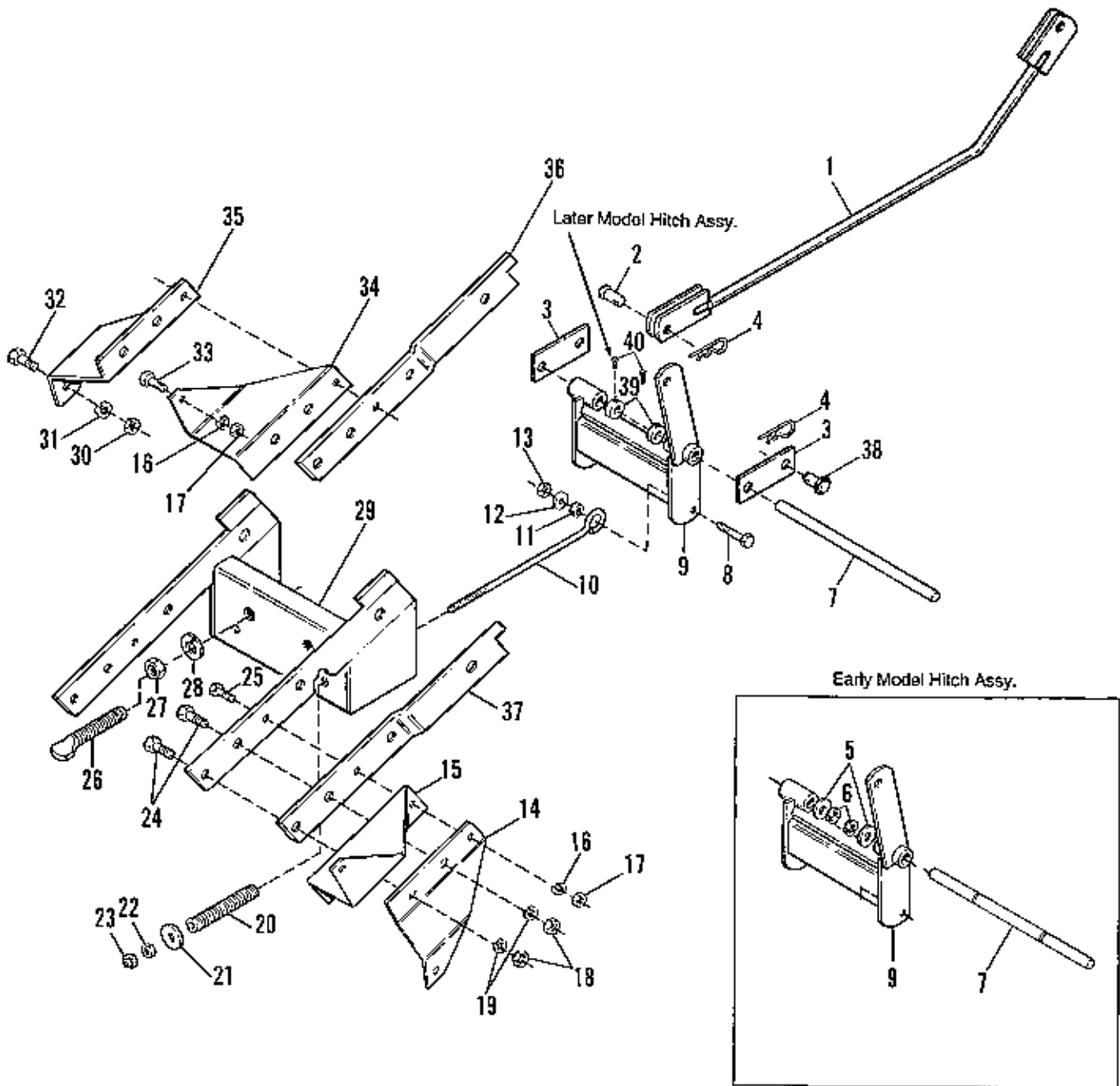

NOTE: Use standard hardware torque spec. chart unless otherwise noted.



## 46" Snowthrower, Hitch Group

Ref. No.	Part No.	Qty.	Description
1	1675390	1	LIFT ROD ASSY.
2	1960038	2	PIN, Clevis
3	1675525	2	LINK
4	1960033	4	CLIP, Hair Pin
5	* 1919387	2	WASHER, Plain, 41/64 x 1-1/4
6	* 927793	2	RING, Retaining, 5/8
7	* 1685484	1	SHAFT, Inner
	** 1708999	1	SHAFT, Inner
8	1922664	2	CAPSCREW, Hex Hd., 5/8-11 x 2
9	1675502	1	HITCH ASSY.
10	1675523	2	EYEBOLT
11	175647	2	SPACER
12	933757	2	WASHER, Plain, 41/64 x 1-3/4
13	1923353	2	NUT, Hex, Centerlock, 5/8-11
14	1703692	1	BRACKET, Attaching, L.H., Lower
15	1703693	1	BRACKET, Attaching, L.H., Upper
16	1916965	4	LOCKWASHER, 3/8
17	1916950	4	NUT, 3/8-16
18	1918213	4	NUT, 7/16-14
19	1918199	4	LOCKWASHER, 7/16
20	1675524	2	SPRING, Compression
21	1960071	2	WASHER, 3/8 x 1-3/4 x 1/4
22	1916950	2	NUT, Hex, 3/8-16
23	1917421	2	NUT, Hex, Jam, 3/8-16
24	1920677	4	CAPSCREW, 7/16-14 x 1-1/4
25	1920415	2	CAPSCREW, 3/8-16 x 1-1/4
26	1676959	2	STUD
27	1913160	2	NUT, Hex, 3/4-10
28	1919332	2	LOCKWASHER, 3/4 Std.
29	1703635	1	HITCH ASSY., Blower
30	1916951	2	NUT, 1/2-13
31	1916966	2	LOCKWASHER, 1/2
32	1923114	2	CAPSCREW, Hex Hd., 1/2-13 x 1
33	1921210	2	CAPSCREW, Hex Hd., 3/8-16 x 1
34	1703694	1	BRACKET, Attaching, R.H., Upper
35	1703695	1	BRACKET, Attaching, R.H., Lower
36	1703696	1	BRACKET, Stop, R.H.
37	1703697	1	BRACKET, Stop, L.H.
38	1703683	2	PIN ASSY. (Flat Head)
39	** 8031007	2	SET-COLLAR
40	** 1928721	2	SET- SCREW, Sq. Hd. cup point, 5/16-18 x 1/2

\* Early Models (see art page)

\*\* Later Models (see art page)

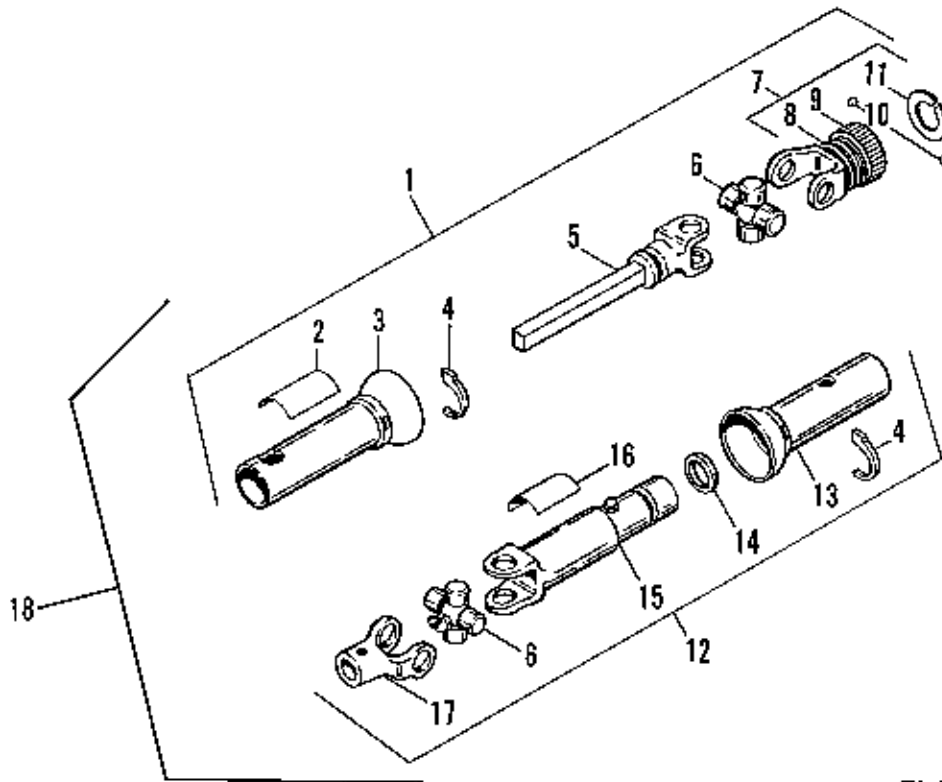

Right Angle Gear Box - Durst

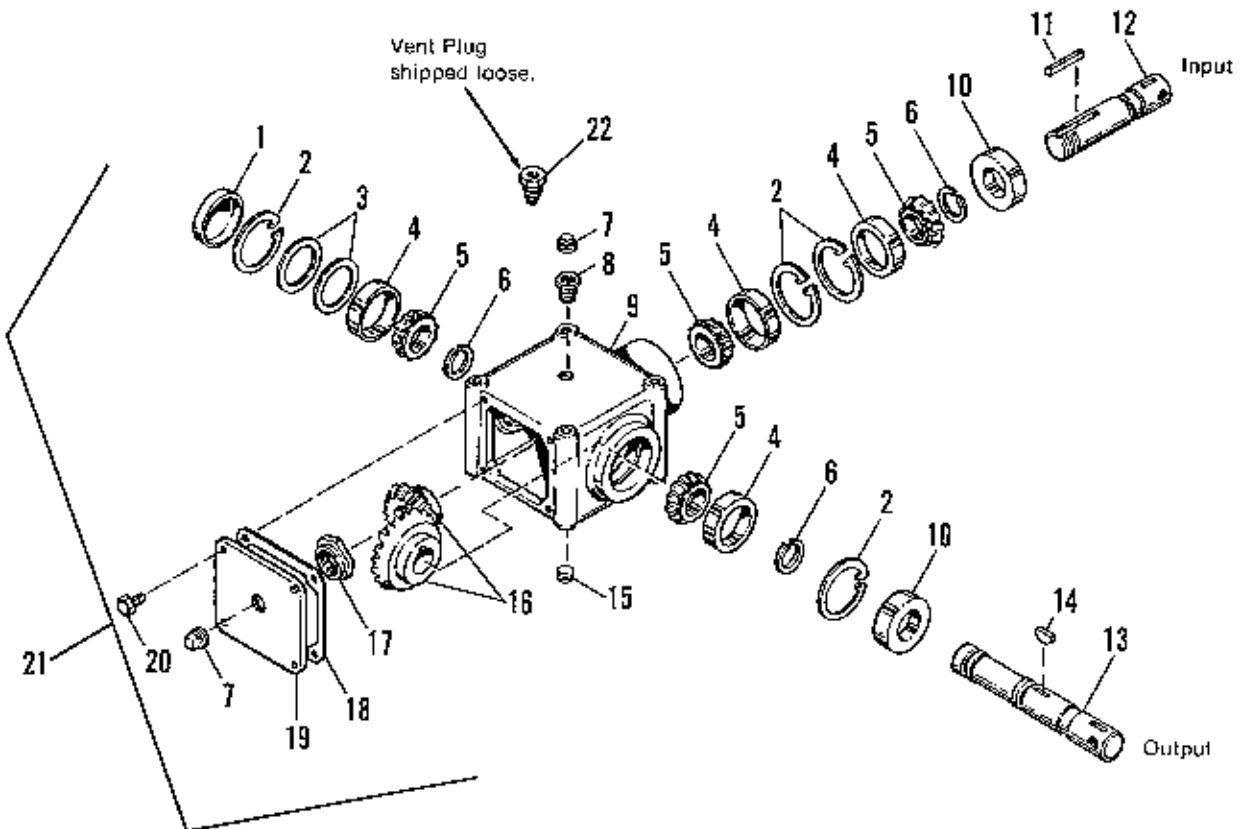

## 42" &amp; 46" Snowthrower, Drive Shaft ("WH" stamped on Weasler Shaft)

Ref. No.	Neapco Part No.	Weasler Part No.	Qty.	Description
1	1678821	1709346	1	DRIVE SHAFT ASSY., Tractor Half (Incl Ref. Nos. 2, 3, Qty. 2 of 4, 5, Qty 1 of Nos. 6, 7 - 11.)
2	1679461	N.A.	1	SHIELD DECAL
3	1679457	1709354	1	SHIELD, Outer
4	1679459	1709352	4	BEARINGS
5	1678822	1709351	1	YOKE & SHAFT ASSY.
6	1678805	1679003	2	JOURNAL ASSY.
7	1678801	1709350	1	YOKE ASSY. (Incl. Ref. Nos. 8 - 11, 28 - 31.)
8	1702432	*	1	SPRING
9	1678802	*	1	SLIDELOCK
10	1678804	*	2	BALLS
11	1679531	*	1	SNAP RING
12	1678823	1709348	1	DRIVE SHAFT ASSY. - Implement Half (Incl. Ref. Nos., Qty. 4 of 4, Qty. 1 of 6, & 13 - 17.)
13	1679458	1709335	1	SHIELD, inner
14	1679460	N.A.	1	NYLON BEARING
15	1678824	1709357	1	YOKE & TUBE ASSY.
16	1678829	N.A.	1	DANGER LABEL
17	1678807	1709358	1	YOKE
18	1675387	1675387	1	COMPLETE DRIVE ASSY (See page 44.)

\* Not Shown : 1685480, Qty. 1, Spring Lock Repair Kit (Weasler only)

## Mfg. No. 1690982

## Right Angle Gear Box - Durst

Ref. No.	Part No.	Qty.	Description
1	173583	1	CAP
2	927700	4	SNAP RING
3	173598		SHIM, Bearing (Use as needed.)
4	170836	4	CUP, Bearing
5	170835	4	BEARING, Cone
6	927320	3	SNAP RING
7	920129	2	PLUG, 1/8-27 NPT
8	1678933	1	REDUCER BUSHING, 1/8-3/8
9	1678926	1	HOUSING
10	1678912	2	SEAL
11	154096	1	KEY, Sq., 1/4 x 1/4 x 29/32 Hard
12	1678929	1	SHAFT, Input
13	1678930	1	SHAFT, Output
14	1678931	1	KEY, Woodruff "A" (807) Hard
15	930674	1	PLUG, Drain, 3/8-18 NPT
16	1678927	2	BEVEL GEAR, 17 Teeth
17	1678928	1	STAKE NUT, 1-18
18	173596	1	GASKET, Cover
19	1678903	1	COVER
20	1921332	4	CAPSCREW, 5/16-18 x 5/8
21	1676047	1	R. ANGLE GEAR CASE ASSY.
22	1678690	1	VENT PLUG, 1/8-27 NPT

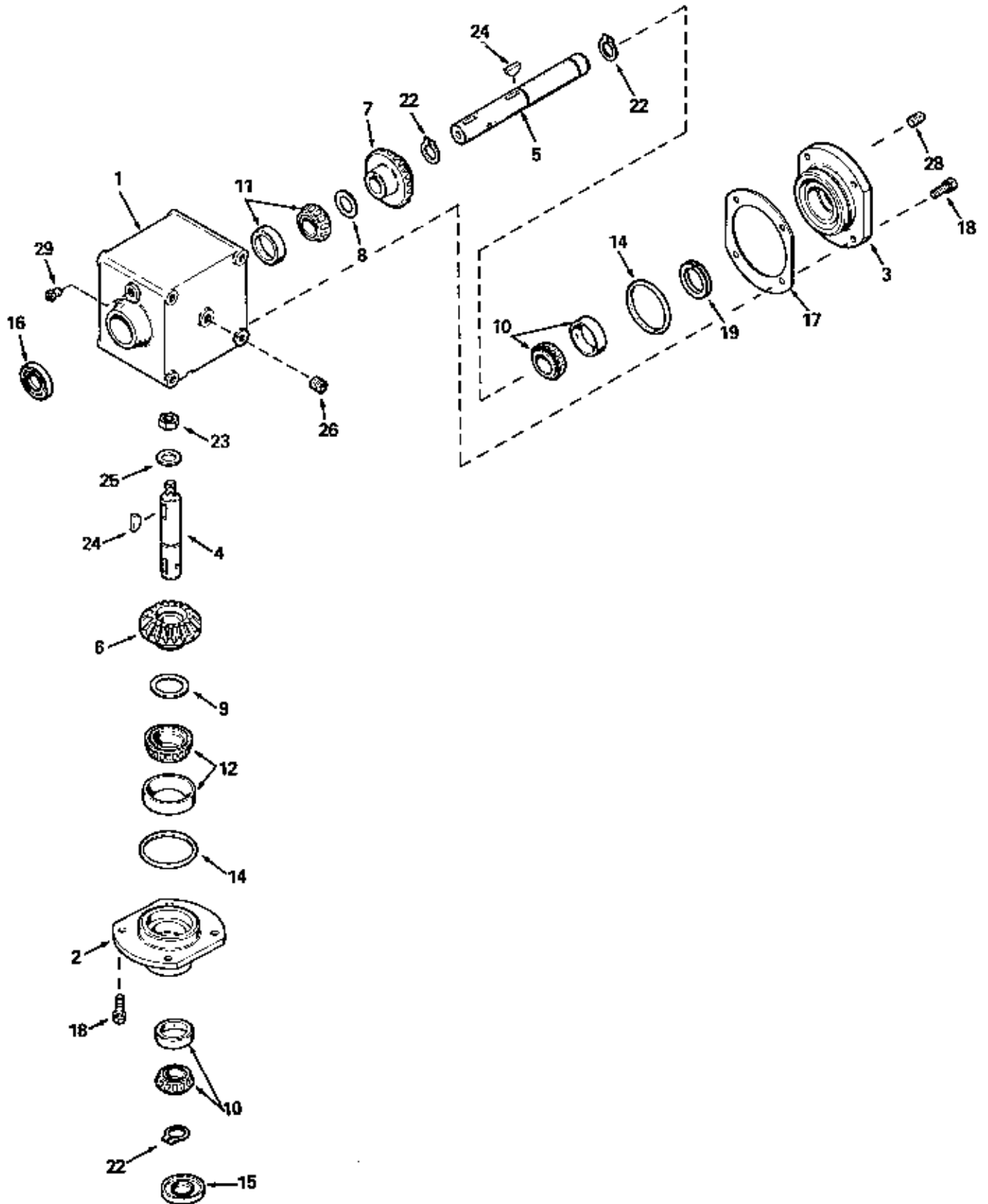

## Right Angle Gear Box - Peerless

Ref. No.	Part No.	Qty.	Description
1	770076		HOUSING, Right Angle Drive
2	786104A		CAP, Retainer
3	786106		CAP, Retainer
4	776221		SHAFT, Input
5	776223		SHAFT, Output
6	778224		GEAR, Bevel (26 Teeth)
7	778223		GEAR, Bevel (25 Teeth)
8	780131		SHIM (1-1/2" OD x 1-1/64" ID x .002 Thick) (Use as required.)
9	780138		SHIM (2.000" OD x 1.531" ID x .002 Thick) (Use as required.)
10	780132		BEARING & CUP ASSY. (This assembly may have a shim washer included. The shim washer is not required at this location.)
11	780132		BEARING & CUP ASSY. (This is a factory sized assembly and may or may not include Ref. No. 8 shim washer. If Ref. No. 8 shim washer is supplied, it must be used on this location. All old shim washers must be discarded.)
12	780134		BEARING & CUP ASSY. (This is a factory sized assembly and may or may not include Ref. No. 9 shim washer. If Ref. No. 9 shim washer is included, it must be used in this locatton. All old shim washers must be discarded.)
14	788063		"O" RING
15	788064		SEAL, Oil
16	788065		SEAL, Oil
17	780136		SHIM, Cap Retainer
18	792037		SCREW, Hex Hd., Sems, 5/16-18 x 1
19	780137		RING, Load
22	792113		RING, Retaining
23	792110		JAM NUT, 3/4-16
24	792114		KEY, Woodruff
25	792115		WASHER, Flat
26	792116		PLUG, Pipe, 1/4-18
28	792039		PLUG, Pipe
29	792118		VALVE, Relief

See an authorized Tecumseh dealer for parts and service. Peerless parts are not available through Simplicity.

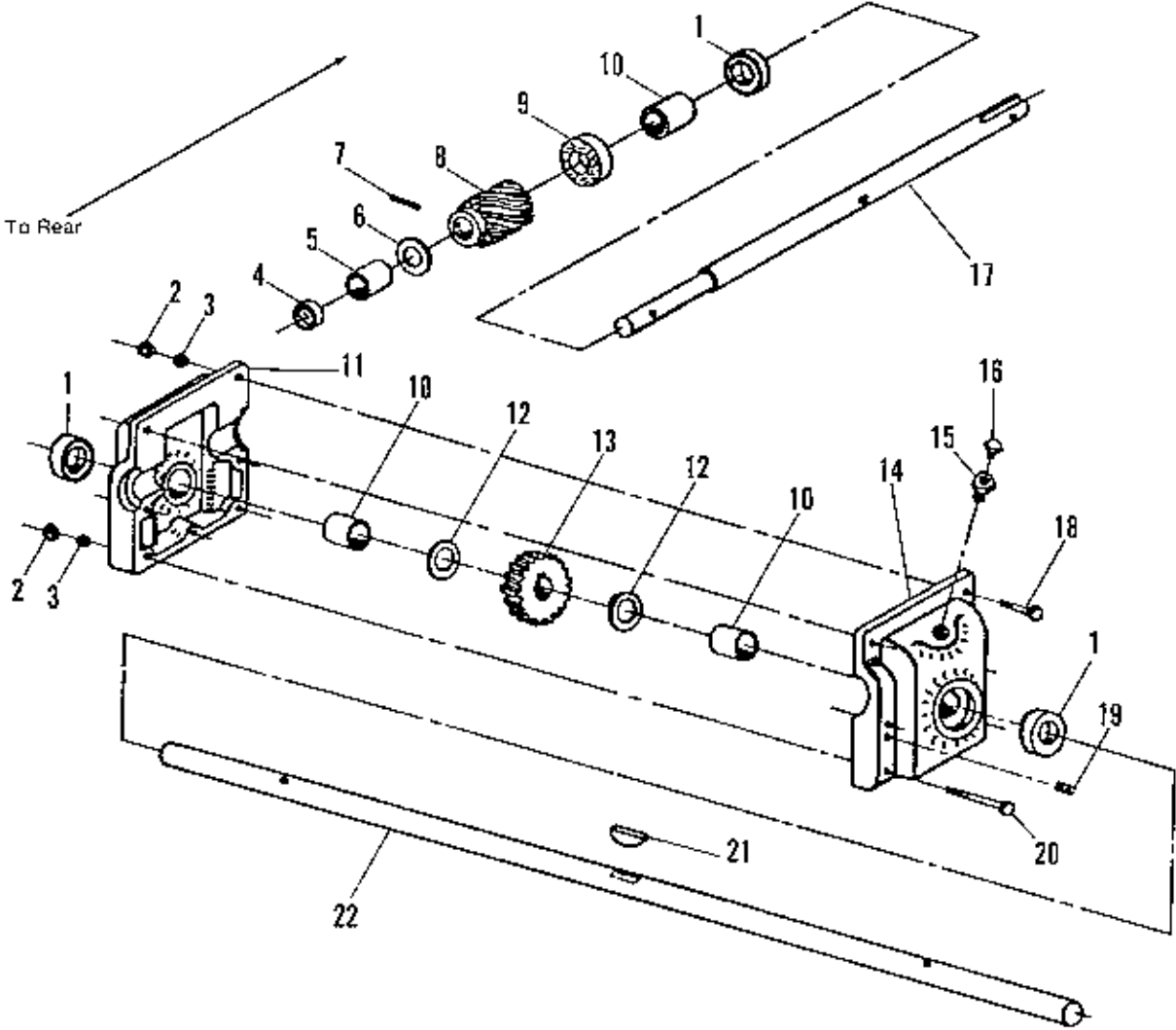

NOTE: Use standard hardware torque spec. chart unless otherwise noted.

## 46" Snowthrower, Gear Assembly

Ref. No.	Part No.	Qty.	Description
1	* 118118	3	SEAL, Oil (1 x 1-1/2 x 1/4)
	** 172588	3	SEAL, Oil (1 x 1-5/16 x 1/8)
2	1917372	6	NUT, Hex, 5/16-18
3	1917355	6	LOCKWASHER, 5/16
4	* 1701060	1	CAP, Input
	** 1707750	1	CAP, Input
5	* 1701059	1	BUSHING, 7/8 x 1-1/8 x 1
	** 1707749	1	BUSHING, 7/8 x 1-1/4 x 1
6	1701058	1	WASHER, 1-3/8
7	1701057	1	PIN, 1/4 x 1-3/8
8	1701056	1	WORM GEAR, R.H. Rotation
9	1701055	1	BEARING
10	1701054	3	BUSHING, 1" I.D. x 1-1/4" O.D. x 1"
11	* 1701061	1	COVER, R.H.
	** 1707751	1	COVER, R.H.
12	1701062	2	WASHER, 1-1/2
13	1701063	1	GEAR, Brass
14	* 1701064	1	COVER, L.H.
	** 1707752	1	COVER, L.H.
15	1678933	1	FITTING, Bushing, Reduction, 7/8 x 1/8 NPT
16	1678690	1	BREATHER, 1/8 NPT
17	* 1701065	1	SHAFT, Input
	** 1707753	1	SHAFT, Input
18	1921977	2	CAPSCREW, Hex Hd., 5/16-18 x 1-1/4
19	917673	1	PLUG, 1/8, NPT
20	1921719	4	CAPSCREW, Hex Hd., 5/16-18 x 2-1/4
21	1678931	1	KEY, Woodruff, 1/4 x 7/8
22	1701066	1	SHAFT, Output

To replace entire Gear Case Assy., order P/N 1707748.

\* Used on Mfg. No. 1691360 before Serial No. 00309.

\*\* Used on Mfg. No. 1691360 after Serial No. 00308.

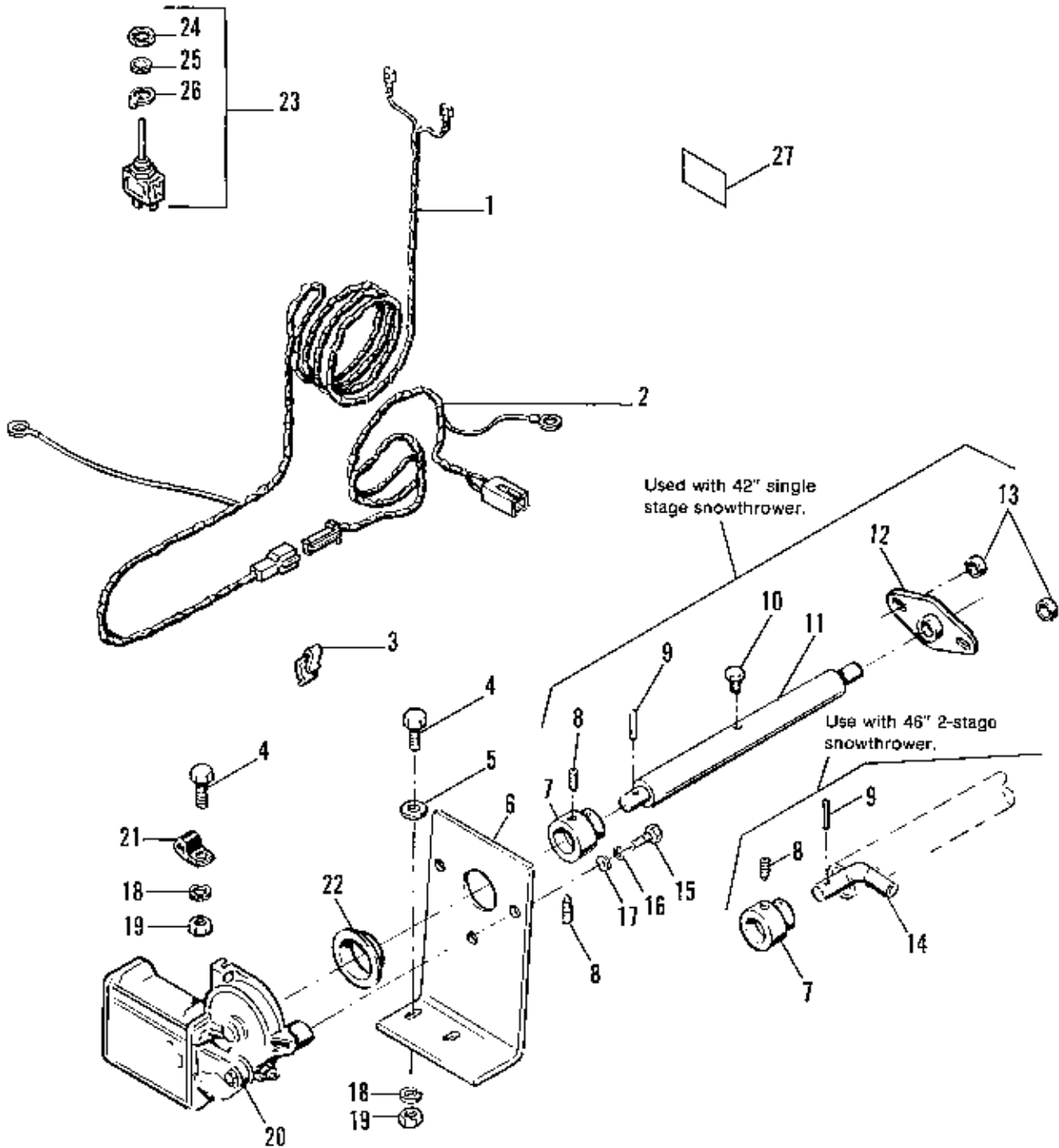

NOTE: Use standard hardware torque spec. chart unless otherwise noted.



## Electric Spout Rotator

Ref. No.	Part No.	Qty.	Description
1	1679168	1	HARNESSES, Wiring, Spout Switch
2	1679167	1	HARNESSES, Wiring, Spout Motor
3	172436	1	CLIP, Cable
4	1921210	3	CAPSCREW, Hex Hd., 3/8-16 x 1
5	1924940	2	WASHER, Plain, 13/32
6	176104	1	BRACKET, Motor
7	174078	1	HUB
8	1930547	3	SCREW, Hex Skt. Hd. Taplite, 1/4-2 x 3/8
9	1926228	2	PIN, Spring 5/32 Dia. x 1 Lg.
10	* 1927428	1	SCREW, Hex Washer Hd. Taplite, 1/4-2 x 3/8
11	* 176102	1	ROD, Spout Control
12	* 106491	1	BEARING, Self Aligning
13	* 165034	2	SPACER
14	** 1700887	1	PIN, Spout Control Rod
15	1923341	3	CAPSCREW, Hex Hd., 1/4-2 x 3/4
16	1918964	3	LOCKWASHER, Spring, 1/4
17	1921319	3	WASHER, Plain, 9/32
18	1918965	3	LOCKWASHER, Spring, 3/8
19	1918950	3	NUT, Hex, 3/8-16
20	1664115	1	MOTOR, Spout Control
21	122186	1	CLAMP
22	174072	1	BEARING, Flange
23	174428	1	SWITCH, Spout Control
24	1650959	1	NUT
25	1650960	1	LOCKWASHER, Int. Th.
26	1650958	1	RING, Locking
27	1679156	1	DECAL, Spout Rotator

\* Used on 42" single stage snowthrower (see page 62).

\*\* Used on 46" 2-stage snowthrower (see page 62).

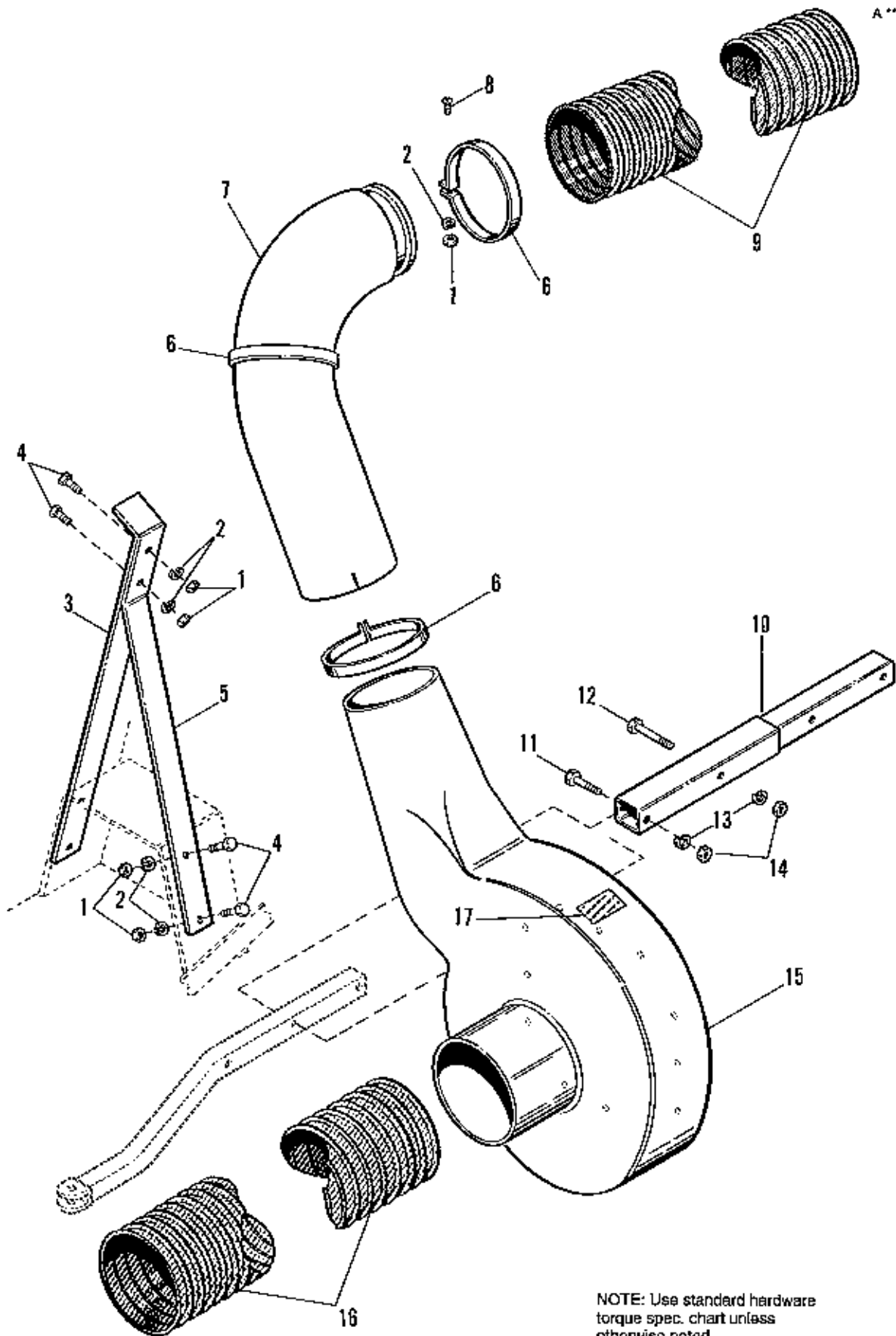

NOTE: Use standard hardware torque spec. chart unless otherwise noted.

Ref. No.	Part No.	Qty.	Description
1	1916622	9	NUT, Hex, 1/4-20 Std.
2	1916964	9	WASHER, Lock, 1/4 Std.
3	1677144	1	SUPPORT, R.H., Outlet Tube
4	1923341	6	CAPSCREW, Hex Hd., 1/4-20 x 3/4
5	1677146	1	SUPPORT, L.H., Outlet Tube
6	123067	3	CLAMP, Hose, 6" Dia.
7	1675511	1	ELBOW, Blower Housing
8	1928866	3	SCREW, Mach. Rd. Hd., 1/4-20 x 3
9	1678490	1	HOSE, Exhaust, 6" Dia. x44" Long
10	1677446	1	HITCH EXTENSION ASSY.
11	1923701	1	CAPSCREW, Hex Hd., 3/8-16 UNC x 2
12	1921972	1	CAPSCREW, Hex Hd., 3/8-16 UNC x 2-1/2
13	1918965	2	WASHER, Lock, 3/8 Std.
14	1916950	2	NUT, Hex, 3/8-16 UNC
15	1685350	1	HOUSING, Fan
16	1677387	1	HOSE, Inlet, 7" Dia. x 44" Long
17	177084	1	DECAL, Caution

## SAFETY DECAL

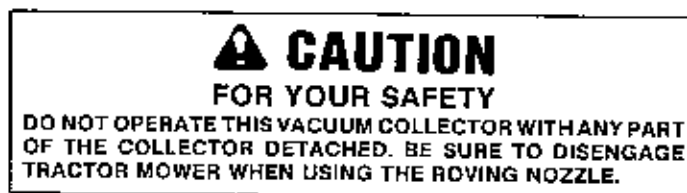

Ref. No. 17

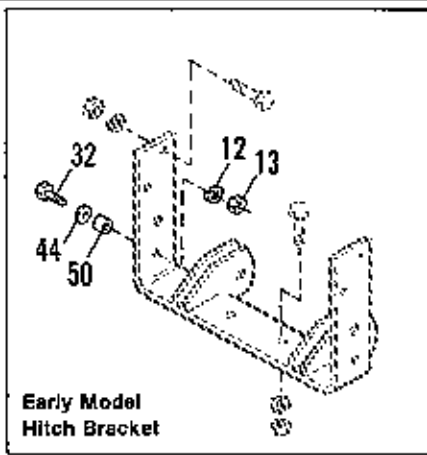

Early Model  
Hitch Bracket

See page 68 for  
Service Parts.

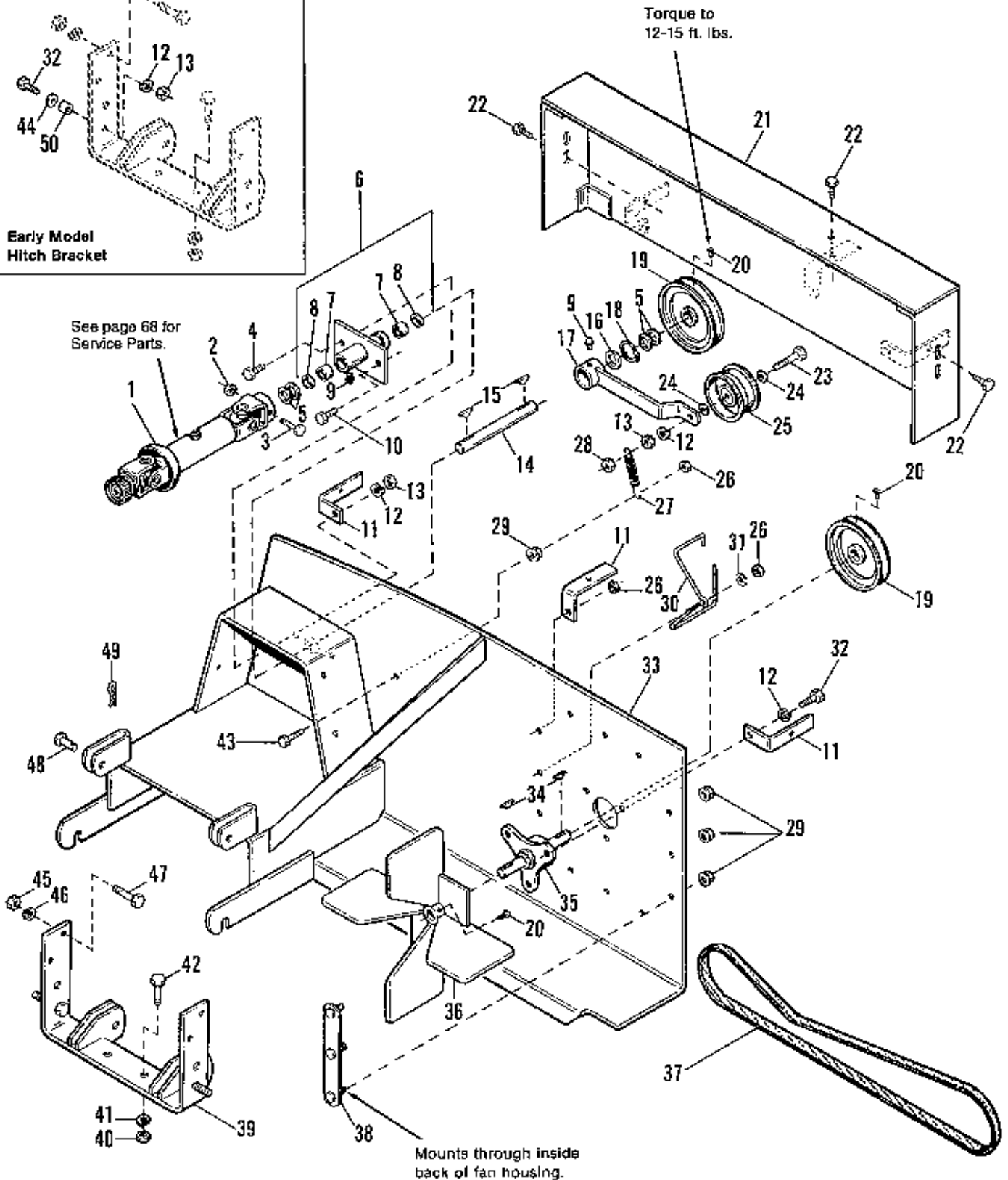

Torque to  
12-15 ft. lbs.

Mounts through inside  
back of fan housing.

NOTE: Use standard hardware  
torque spec. chart unless  
otherwise noted.

## Vacuum Collector, Frame &amp; Drive Group

Ref. No.	Part No.	Qty.	Description
1	1679594	1	DRIVE SHAFT ASSY., w/Shield (See page 68 for service parts.)
2	1923358	1	NUT, Hex, Lock, 1/4-20
3	1921963	1	CAPSCREW, Hex Hd., 1/4-20 x 2
4	1921965	1	CAPSCREW, Hex Hd., 3/8-16 x 3/4, Gr. 5
5	960231	4	WASHER, Thrust, 3/4 x 1-3/8 x 1/16
6	1677364	1	SUPPORT ASSY. (Incl. Ref. Nos. 7, 8 & 9)
7	154258	2	BEARING, Needle
8	1611789	2	SEAL
9	921139	2	FITTING, Grease
10	1921210	1	CAPSCREW, Hex Hd., 3/8-16 x 1
11	1677412	3	BRACE, Bell Cover
12	1916965	6	LOCKWASHER, Spring, 3/8
13	1916950	3	NUT, Hex, 3/8-16
14	1677127	1	SHAFT, Vacuum Collector
15	930672	2	KEY, Hi-Pro, 3/16 x 5/8
16	960177	1d	WASHER
17	1676120	1	PIVOT ASSY., Idler
18	927744	1	EXTERNAL SNAP RING, 1-3/8
19	106663	2	PULLEY
20	1928721	3	SETSCREW, Sq. Hd., 5/16-18 x 1/2
21	1677266	1	BELT GUARD ASSY.
22	1927428	3	SCREW, Taptite, 1/4-20 x 3/8
23	1923701	1	CAPSCREW, Hex Hd., 3/8-16 x 2, Gr. 5
24	1917378	2	WASHER, Plain, 3/8 Std.
25	1657712	1	PULLEY, Idler
26	1928698	3	NUT, Hex, Centerlock, Jam, 5/16-18
27	174896	1	SPRING, Tension, Idler
28	1930651	1	NUT, Hex, Centerlock, 3/8-16
29	1927557	11	NUT, Hex, Flange, Whizlock, 5/16-18
30	1677329	1	STOP, Belt
31	1917642	1	WASHER, Plain, 5/16 Std.
32	1921210	3	CAPSCREW, Hex Hd., 3/8-16 x 1
33	1677158	1	FRAME ASSY.
34	930670	2	KEY, Hi-Pro, 3/16 x 3/4
35	123087	1	FLANGE, SHAFT & BEARING ASSY.
36	123015	1	FAN ASSY.
37	1677488	1	BELT, Drive
38	1657456	4	BAR, Housing
39	1679731	1	BRACKET, Assy. Hitch
40	1916951	2	NUT, Hex, 1/2-13
41	1916966	2	WASHER, Springlock, 1/2
42	1921176	2	CAPSCREW, Hex Hd., 1/2-13 x 1-1/4
43	1921333	1	CAPSCREW, Hex Hd., 5/16-18 x 1, Gr. 5
44	* 1922755	2	WASHER, Plain, 3/8-1 x 1/8
45	1918219	4	NUT, Hex, 7/16-14
46	1918199	4	WASHER, Springlock, 7/16
47	1920677	4	CAPSCREW, Hex Hd., 7/16-14 x 1-1/4
48	8271015	2	CLEVIS, Pin, 3/8 x 1-1/4
49	1918196	2	QUICK PIN, 3/32 x 1-7/8
50	* 174870	2	SPACER

\* "Early Model" hitches only, see art on page 66.

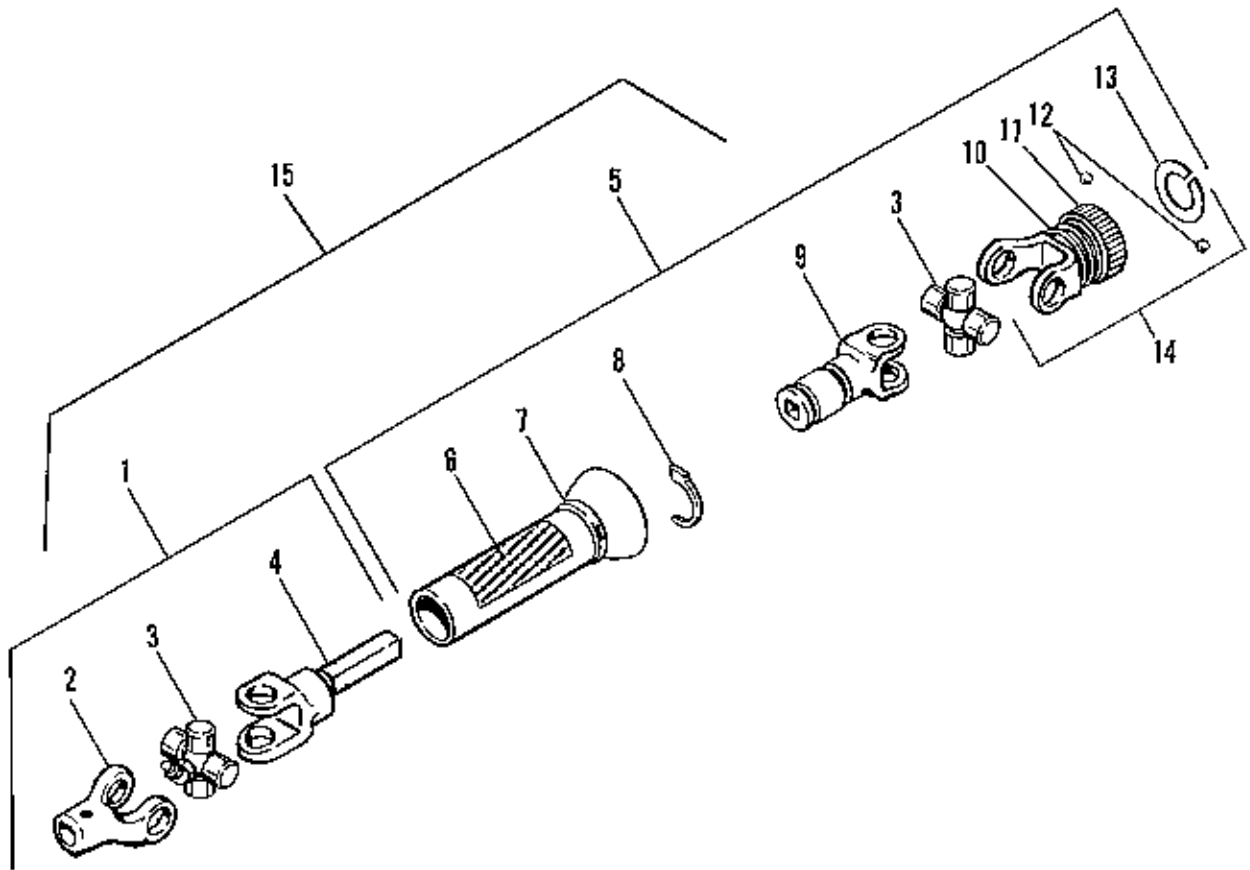

Vacuum Collector, Drive Group

---

Ref. No.	Part No.	Qty.	Description
1	1678865	1	YOKE & SHAFT ASSY. (Incl. Ref. Nos. 2, Qty. 1 of 3, & 4)
2	1678864	1	YOKE
3	1678805	2	JOURNAL ASSY.
4	1678863	1	YOKE & SHAFT
5	1678944	1	SLIP YOKE ASSY., w/Shield (Incl. Qty. 1 of Ref. No. 3 & Ref. Nos 6 - 14.)
6	1679461	1	DECAL, Shield
7	1678867	1	SHIELD
8	1678827	3	BEARINGS
9	1679661	1	SLIP YOKE ASSY.
10	1678803	1	SPRING
11	1678802	1	SLIDE LOCK
12	1678804	2	BALLS
13	1679531	1	SNAP RING
14	1678801	1	YOKE ASSY. (Incl. Ref. Nos. 10 - 13)
15	1679594	1	COMPLETE DRIVE SHAFT ASSY.

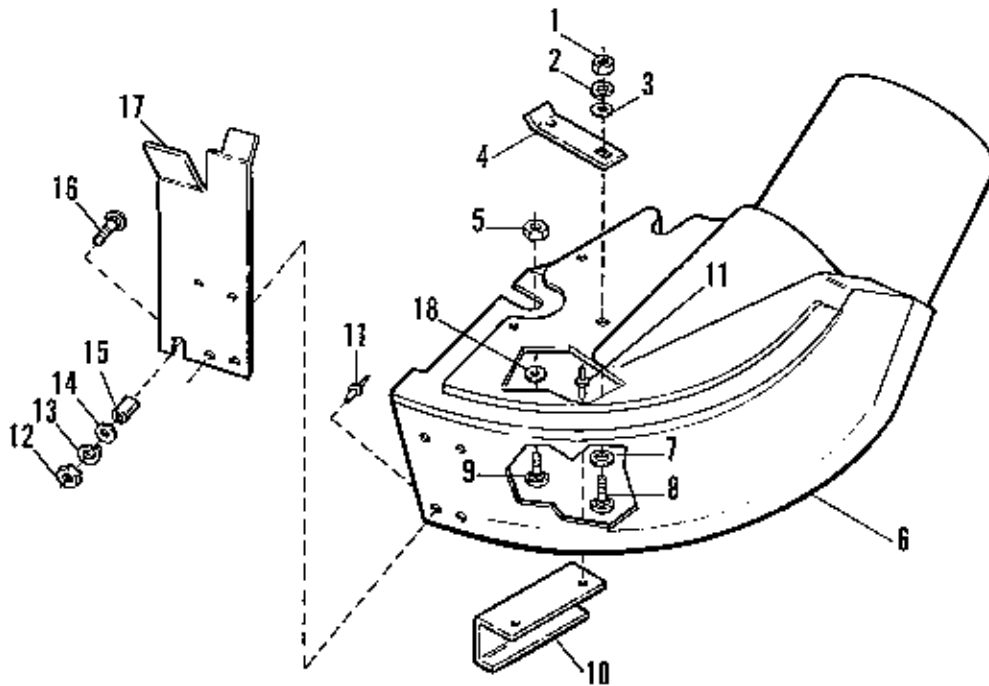

NOTE: Use standard hardware torque spec. chart unless otherwise noted.

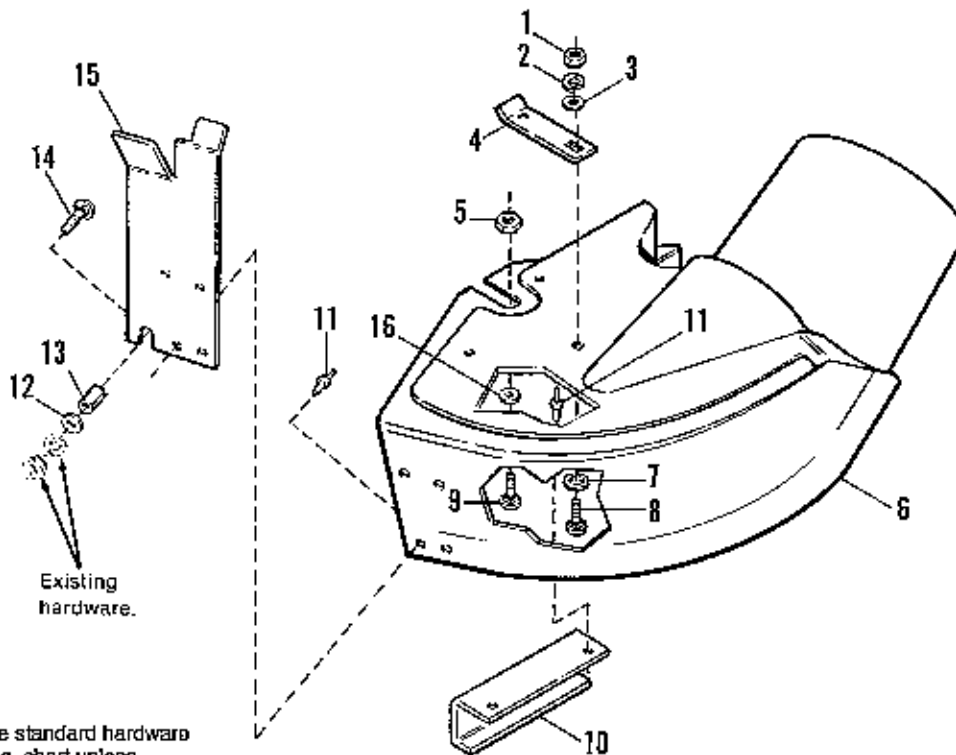

NOTE: Use standard hardware torque spec. chart unless otherwise noted.



## 42" Adaptor Group - Vacuum Collector

Ref. No.	Part No.	Qty.	Description
1	1917372	1	NUT, Hex, 5/16-18 UNC, 2B
2	1917356	1	LOCKWASHER, 5/16, Helical Spring
3	1917642	1	WASHER, Plain, 3/8 x 7/8
4	1678786	1	LATCH, Spring
5	1960251	1	NUT, Hex, Centerlock, Jam, 3/8-16 UNC
*6		1	ADAPTOR ASSY.
7	1917378	1	WASHER, Plain, 7/16 x 1
8	1931335	1	BOLT, Rd. Hd., 5/16-18 UNC x 1
9	1931349	1	BOLT, Rd. Hd., 3/8-16 UNC x 7/8
10	1679548	1	ADAPTOR, Hold Down
11	928706	6	RIVET, Oval Hd., 3/16 x 5/16
12	1916950	1	NUT, Hex, 3/8-16 UNC
13	1916965	1	LOCKWASHER, 3/8 Helical Spring
14	1919384	1	WASHER, Plain, 3/8 x 1-1/4 x 1/8
15	1663752	1	SPACER
16	1931350	1	BOLT, Rd. Hd., 3/8-16 UNC x 1
17	1700260	1	DEFLECTOR BRACE ASSY.
18	1960027	1	WASHER, Plain, 1/2 x 7/8

\*Order complete Adaptor Assembly, Mfg. No. 1691170.

## 48" Adaptor - Vacuum Collector

Ref. No.	Part No.	Qty.	Description
1	1917372	1	NUT, Hex, 5/16-18 UNC, 2B
2	1917356	1	LOCKWASHER, 5/16 Helical Spring
3	1917642	1	WASHER, Plain, 3/8 x 7/8
4	1678786	1	LATCH, Spring
5	1960251	1	NUT, Hex, Centerlock, Jam, 3/8-16 UNC
*6		1	ADAPTOR ASSY.
7	1917378	1	WASHER, Plain, 7/16 x 1
8	1931335	1	BOLT, Rd. Hd., 5/16-18 UNC x 1
9	1931349	1	BOLT, Rd. Hd., 3/8-16 UNC x 7/8
10	1679548	1	ADAPTOR, Hold Down
11	928706	6	RIVET, Oval Hd., 3/16 x 5/16
12	1919384	1	WASHER, Plain, 3/8 x 1-1/4 x 1/8
13	1663752	1	SPACER
14	1923220	1	BOLT, Rd. Hd., 3/8-16 UNC x 1-1/4
15	1700260	1	DEFLECTOR BRACE ASSY.
16	1960027	1	WASHER,, Plain, 1/2 x 7/8

\*Order complete Adaptor Assembly, Mfg. No. 1691171.

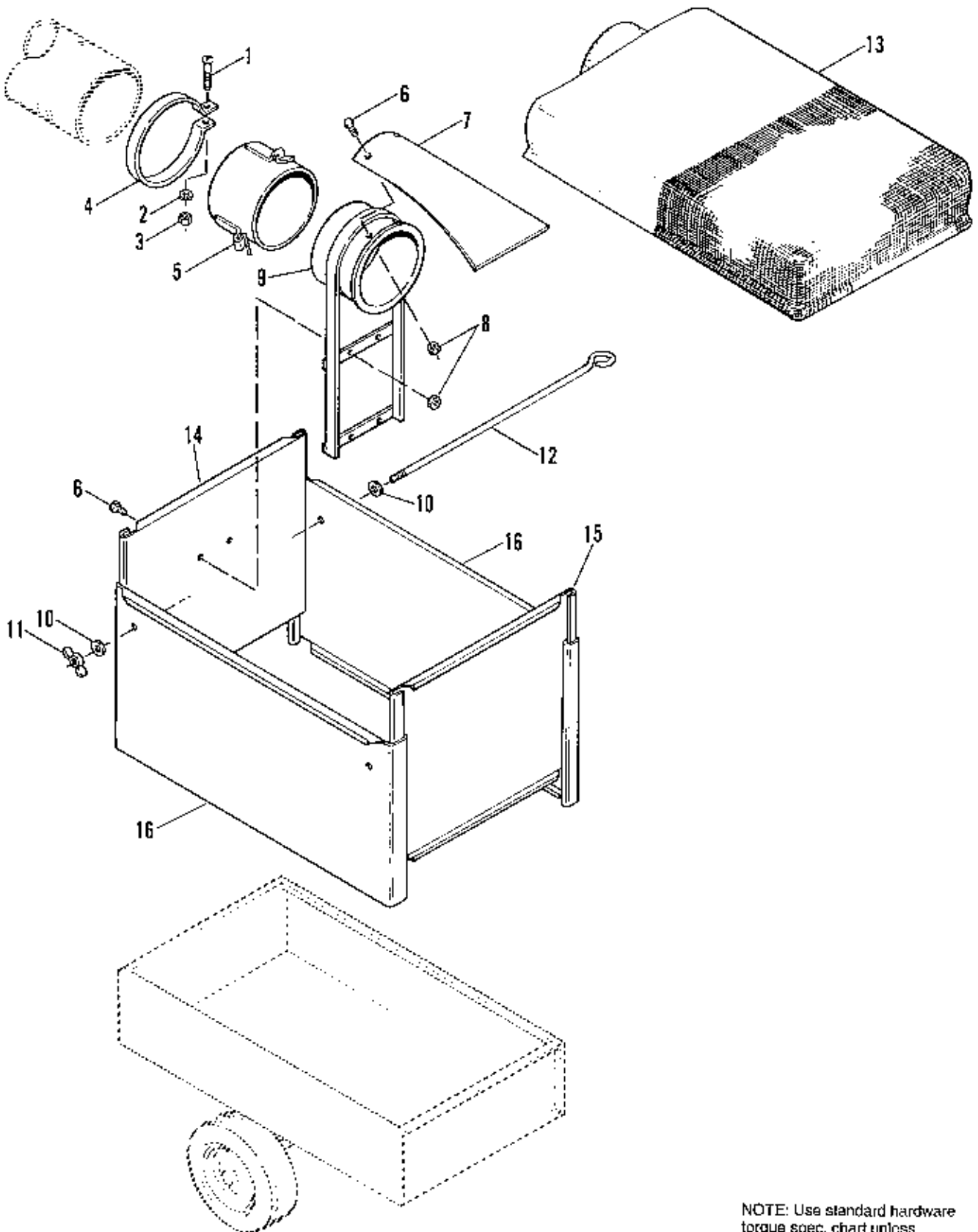

NOTE: Use standard hardware torque spec. chart unless otherwise noted.

Cart Cover & Side Extension Group

---

Ref. No.	Part No.	Qty.	Description
1	1928866	1	SCREW, Rd. Hd., 1/4-20 x 3
2	1916964	1	LOCKWASHER, 1/4
3	1916622	1	NUT, Hex, 1/4-20
4	123067	1	CLAMP, Hose, 6" Dia.
5	1665782	1	CONNECTOR, Hose 6"
6	1921959	4	CAPSCREW, Hex Hd., 1/4-20 x 5/8
7	1665781	1	DEFLECTOR
8	1923358	4	LOCKNUT, Hex, 1/4-20
9	1665780	1	CONNECTOR, Metal, 6"
10	1917377	4	WASHER
11	916952	2	WINGNUT, 1/4-20
12	1665778	2	ROD, 17"
13	1665779	1	BONNET
14	1665777	1	PANEL, Front
15	1665776	1	PANEL, Rear
16	1665775	2	PANEL, Side

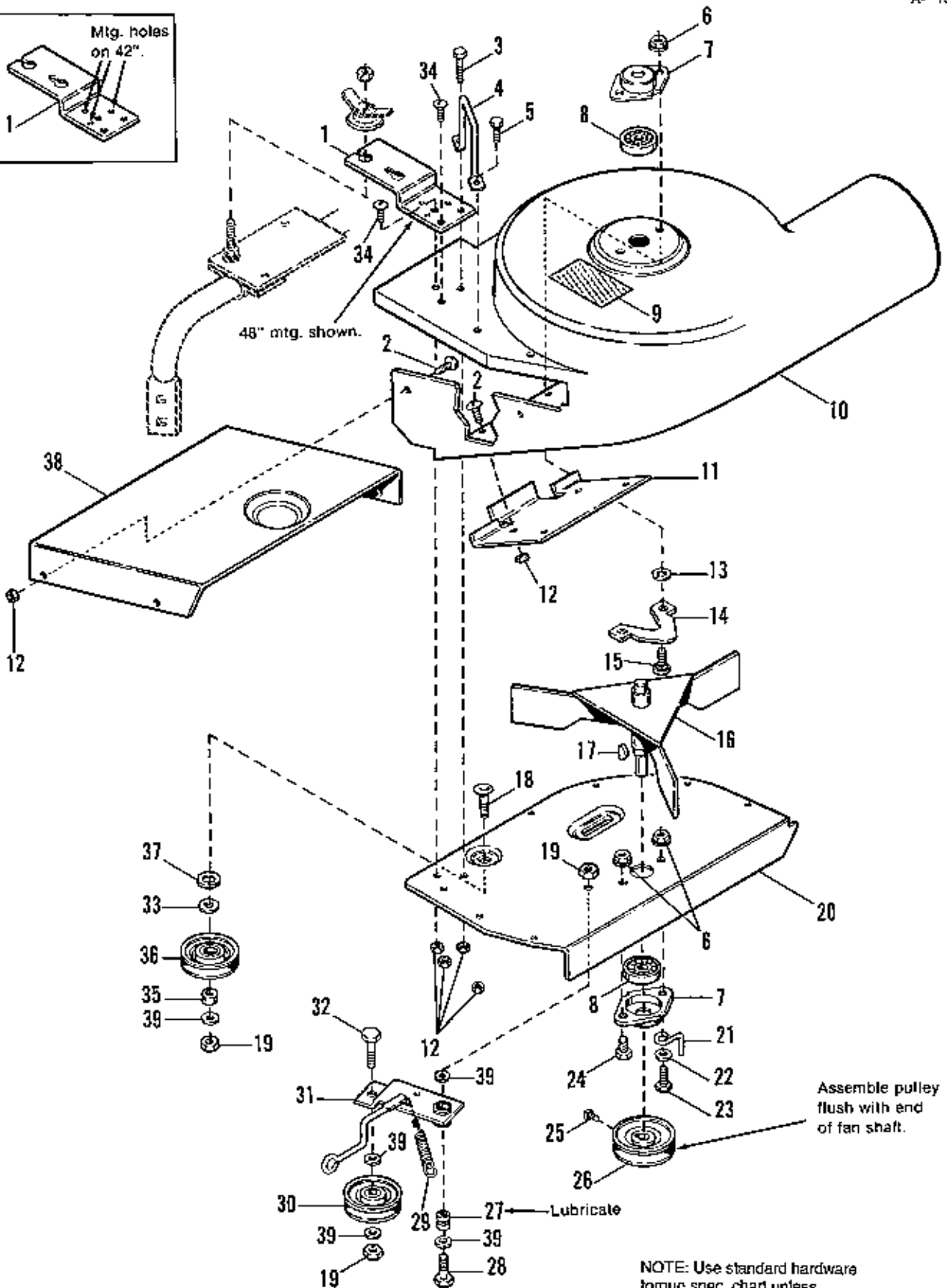
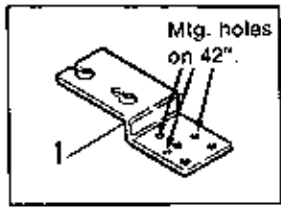

Ref. No.	Part No.	Qty.	Description
1	1679897	1	MOUNTING PLATE
2	1921959	16	CAPSCREW, Hex Hd., 1/4-20 x 5/8
3	1924009	1	CAPSCREW, Hex, 1/4-20 x 7/8
4	1700936	1	STOP, Deflector
5	1923341	1	CAPSCREW, Hex, 1/4-20 x 3/4
6	1927557	4	NUT, Flange, Lock, 5/16-18
7	1667341	2	BEARING, Retainer
8	1705897	2	BEARING
9	1700259	1	DECAL, Warning
10	1700922	1	HOUSING, Blower (Incl. Ref. No. 9)
11	1679900	1	HOOK, Stoneguard
12	1930641	17	NUT, Hex Flange Whizlock, 1/4-20
13	933988	2	PUSH NUT, 5/16
14	1678811	1	PLATE, Flange
15	1931333	2	CARRIAGE BOLT, 5/16-18 x 3/4
16	1678601	1	FAN ASSY.
17	918312	1	KEY, Woodruff
18	1960268	1	CARRIAGE BOLT, 3/8-16 x 1-1/4
19	1928731	2	NUT, Hex Jam Lock, 3/8-16
20	1679901	1	PLATE, Shroud
21	1678924	1	STOP, Belt
22	1919326	1	WASHER, Plain, 11/32
23	1960104	1	CAPSCREW, Thin Hd., 5/16-18 x 3/4
24	1920787	1	CAPSCREW, Hex Hd., 5/16-18 x 1/2
25	1928691	1	SETSCREW, Socket Hd., 5/16-18 x 5/16
26	1678612	1	PULLEY, Driven
27	1666114	1	SPACER
28	1921969	1	CAPSCREW, Hex Hd., 3/8-16 x 1-1/2
29	1679554	1	SPRING, Tension
30	174561	1	PULLEY, Idler, Adjustable
31	1701827	1	IDLER ARM ASSY.
32	1921210	1	CAPSCREW, 3/8-16 x 1
33	1928731	1	LOCKNUT, Hex, Jam, 3/8-16
34	1935945	2	SCREW, Truss Hd., 1/4-20 x 3/4
35	1666294	1	SPACER
36	1708030	1	PULLEY, Idler, Fixed
37	1924361	1	WASHER, Plain, 1/2
38	1700635	1	COVER, Top
39	1924940	5	WASHER, 13/32

## SAFETY DECAL



Ref. No. 9 SAFETY DECAL



Ref. No.	Part No.	Qty.	Description
1	1679897	1	MOUNTING PLATE
2	1921959	15	CAPSCREW, Hex Hd., 1/4-20 x 5/8
3	1960346	1	CAPSCREW, Hex, 1/4-20 x 2-1/4
4	1700936	1	STOP, Deflector
5	1924009	1	CAPSCREW, Hex, 1/4-20 x 7/8
6	1927557	4	NUT, Flange, Lock, 5/16-18
7	1667341	2	BEARING, Retainer
8	1705897	2	BEARING
9	1700259	1	DECAL, Warning
10	1702640	1	HOUSING, Blower (Incl. Ref. No. 9)
11	1679900	1	HOOK, Stoneguard
12	1930641	17	NUT, Hex Flange Whizlock, 1/4-20
13	933988	4	PUSH NUT, Nylon, 1/4-20
14	1678811	1	PLATE, Flange
15	1931333	3	CARRIAGE BOLT, 5/16-18 x 3/4
16	1702433	1	FAN ASSY. (5 Blade)
17	918312	1	KEY, Woodruff
18	1960268	1	CARRIAGE BOLT, 3/8-16 x 1-1/4
19	1928731	3	NUT, Hex Jam Lock, 3/8-16
20	1702554	1	PLATE, Shroud
21	170397	1	STOP, Belt
22	1919326	1	WASHER, Plain, 11/32
23	1960104	2	CAPSCREW, Thin Hd., 5/16-18 x 3/4
24	1702563	1	BUSHING
25	1928691	1	SETSCREW, Socket Hd., 5/16-18 x 3/8
26	1702685	1	PULLEY, Driven
27	1666114	1	SPACER
28	1921969	1	CAPSCREW, Hex Hd., 3/8-16 x 1/2
29	1679554	1	SPRING, Tension
30	174561	1	PULLEY, Idler, Adjustable
31	1701827	1	IDLER ARM ASSY.
32	1921210	1	CAPSCREW, 3/8-16 x 1
33	157424	1	WASHER, Special
34	1935946	2	SCREW, Truss Hd., 1/4-20 x 3/4
35	1666294	1	SPACER
36	1708030	1	PULLEY, Idler, Fixed
37	1676435	1	WASHER, Plain, 1/2
38	1702553	1	COVER, Top
39	1917356	1	WASHER, Spring
40	1917372	1	NUT, Hex, 5/16
41	1924940	5	WASHER, 13/32

## SAFETY DECAL



Ref. No. 9





## Turbo Collector (42" &amp; 48" Mowers) - Blower Group

Ref. No.	Part No.	Qty.	Description
1	1679897	1	MOUNTING PLATE
2	1921959	13	SCREW, Hex Hd., 1/4-20 x 5/8
3	1960346	1	CAPSCREW, Hex, 1/4-20 x 2-1/4
4	1700936	1	STOP, Deflector
5	1924009	1	CAPSCREW, Hex, 1/4-20 x 7/8
6	1927557	6	NUT, Flange, Lock, 5/16-18
7	1665982	4	BEARING, Retainer
8	108202	2	BEARING
9	1700259	1	DECAL, Warning
10	1706654	1	HOUSING, Blower (Incl. Ref. No. 9)
11	1679900	1	HOOK, Stoneguard
12	1930641	17	NUT, Hex Flange Whiz, 1/4-20
13	933988	6	PUSH NUT, Nylon, 1/4-20
14	1676435	1	WASHER, Plain, 1/2
15	1931333	7	CARRIAGE BOLT, 5/16-18 x 3/4
16	1706631	1	FAN ASSY. (5 Blade)
17	960403	1	KEY, Woodruff
18	1960268	1	CARRIAGE BOLT, 3/8-16 x 1-1/4
19	1928731	3	NUT, Hex Jam Lock, 3/8-16
20	1706652	1	PLATE, Shroud
21	170397	1	STOP, Belt
22	1919326	1	WASHER, Plain, 11/32
23	1702553	1	COVER, Top
24	1924940	5	WASHER, 13/32
25	1928691	1	SETSCREW, Sq. Hd., 5/16-18 x 3/8
26	1706634	1	PULLEY, Driven
27	1666114	1	SPACER
28	1921969	1	CAPSCREW, Hex Hd., 3/8-16 x 1/2
29	1679554	1	SPRING, Tension
30	174561	1	PULLEY, Idler, Adjustable
31	1701827	1	IDLER ARM ASSY.
32	1921210	1	CAPSCREW, 3/8-16 x 1
33	157424	1	WASHER, Special
34	1917356	1	LOCKWASHER, 5/16
35	1917372	1	NUT, Hex, 5/16
36	1708030	1	PULLEY, Idler, Fixed
37	1923341	2	CAPSCREW, Hex Hd., 1/4-20 x 3/4

## SAFETY DECAL

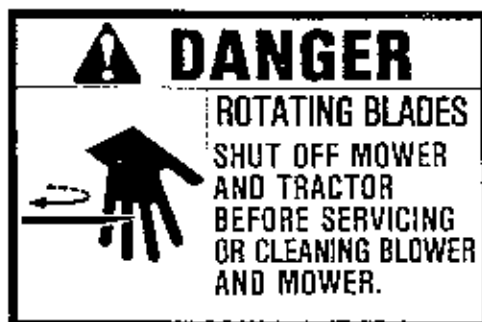

Ref. No. 9

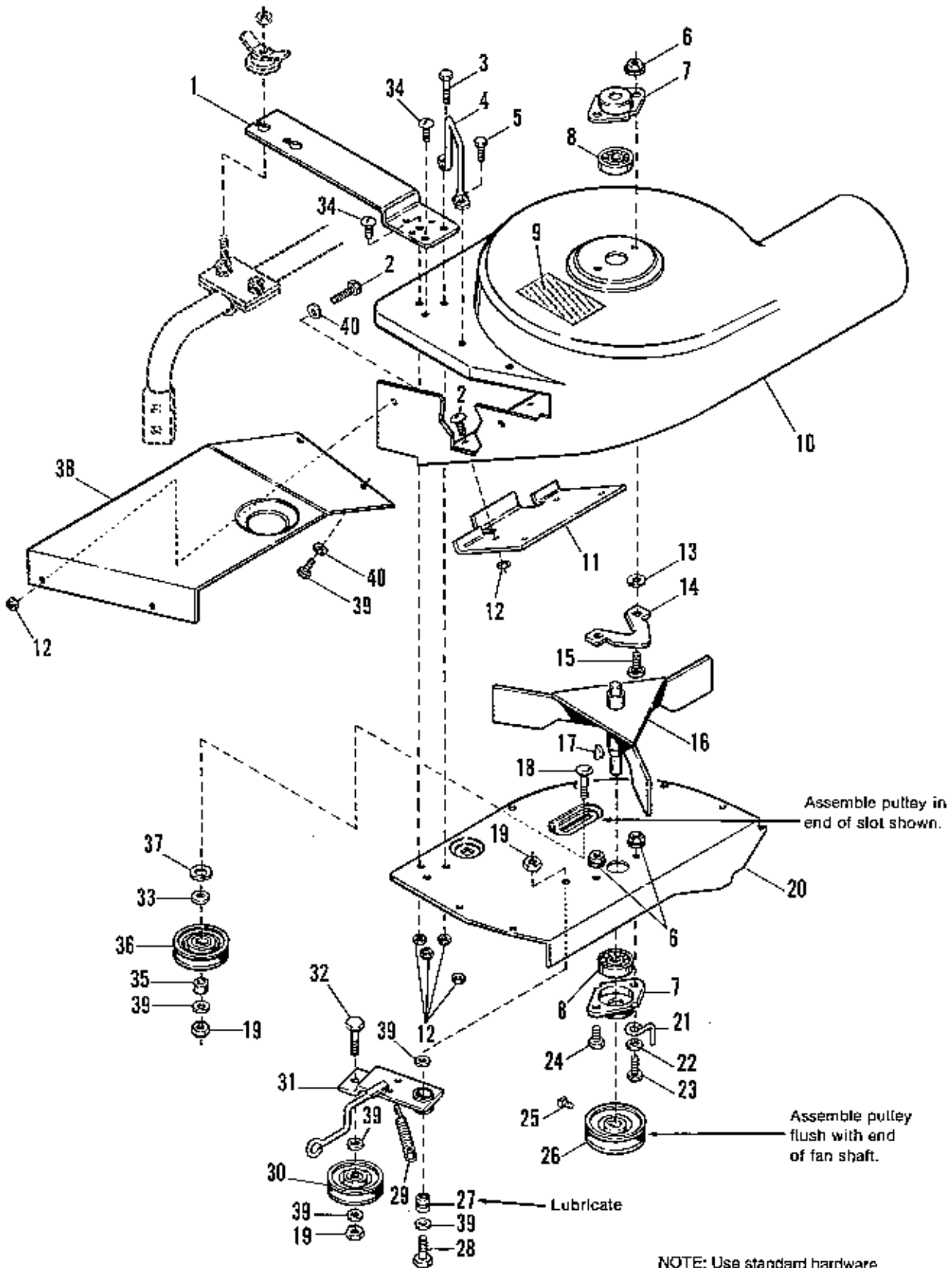

Ref. No.	Part No.	Qty.	Description
1	1678912	1	MOUNTING PLATE, 60"
2	1921959	15	CAPSCREW, Hex Hd., 1/4-20 x 5/8
3	1924009	1	CAPSCREW, Hex, 1/4-20 x 7/8
4	1700936	1	STOP, Deflector
5	1923341	1	CAPSCREW, Hex, 1/4-20 x 3/4
6	1927557	4	NUT, Flange Lock, 5/16-18
7	1867341	2	BEARING, Retainer
8	1705897	2	BEARING
9	1700259	1	DECAL, Warning
10	1700921	1	TURBO HOUSING (Incl. Ref. No. 9)
11	1679900	1	HOOK, Stoneguard
12	1930641	17	NUT, Hex Flange Whizlock 1/4-20
13	933988	2	PUSHNUT, 5/16 Stud
14	1678811	1	PLATE, Flange
15	1931333	2	CARRIAGE BOLT, 5/16-18 x 3/4
16	1678601	1	FAN ASSY.
17	1918312	1	KEY, Woodruff
18	1960268	1	CARRIAGE BOLT, 3/8-16 x 1-1/4
19	1928731	2	NUT, Hex Jam Lock, 3/8-16
20	1700845	1	PLATE, Shroud
21	1678924	1	STOP, Belt
22	1919326	1	WASHER, Plain, 11/32
23	1960104	1	CAPSCREW, Hex, Thin Hd., 5/16-18 x 3/4
24	1920787	1	CAPSCREW, 5/16-18 x 1/2
25	1928691	1	SET SCREW, Socket Hd., 5/16-18 x 3/8
26	1678612	1	PULLEY, Driven
27	1666114	1	SPACER
28	1921969	1	CAPSCREW, Hex, 3/8-16 x 1-1/2
29	1679554	1	SPRING, Tension
30	174581	1	PULLEY, Idler
31	1701827	1	IDLER ARM ASSY.
32	1921210	1	CAPSCREW, 3/8-16 x 1
33	1928731	1	LOCKNUT, Hex, Jam, 3/8-16
34	1935945	2	SCREW, Truss Hd., 1/4-20 x 3/4
35	1666294	1	SPACER
36	1708030	1	PULLEY, Idler.
37	1924361	1	WASHER, Plain, 1/2
38	1700658	1	COVER, Top
39	1924940	5	WASHER, Plain, 13/32
40	1921319	4	WASHER, Plain, 9/32

## SAFETY DECAL

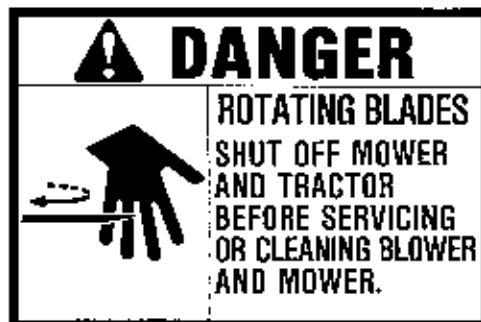

Ref. No. 9

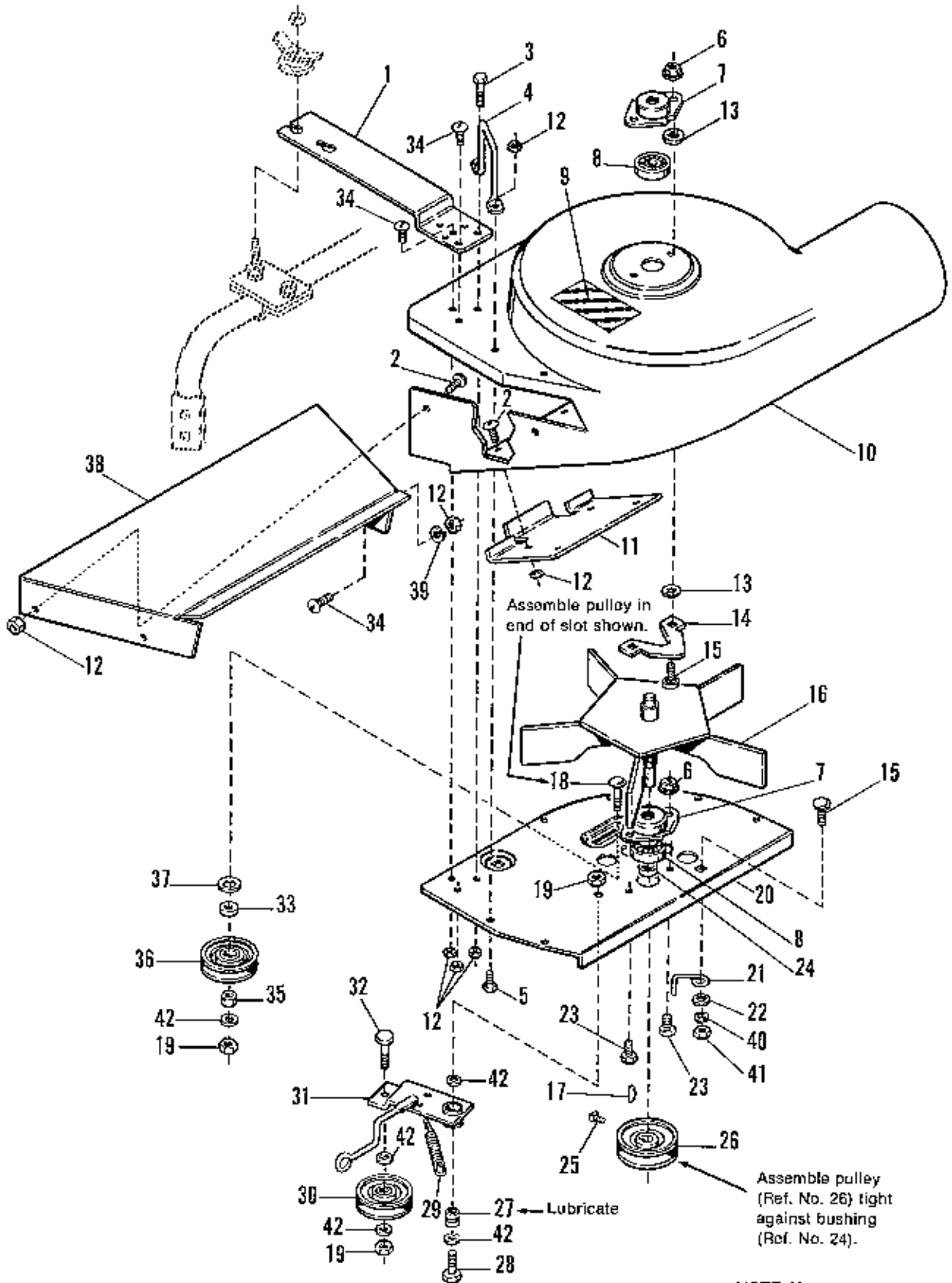

## 60" Turbo Collection System - Blower Group

Ref. No.	Part No.	Qty.	Description
1	1679912	1	MOUNTING PLATE, 60"
2	1921959	15	CAPSCREW, Hex Hd., 1/4-20 x 5/8
3	1960346	1	CAPSCREW, Hex, 1/4-20 x 2-1/4
4	1700936	1	STOP, Deflector
5	1924009	1	CAPSCREW, Hex, 1/4-20 x 7/8
6	1927557	4	NUT, Flange Lock, 5/16-18
7	1667341	2	BEARING, Retainer
8	1705897	2	BEARING
9	1700259	1	DECAL, Warning
10	1702639	1	TURBO HOUSING (Incl. Ref. No. 9)
11	1679900	1	HOOK, Stoneguard
12	1930641	17	NUT, Hex Lock Nylon, 1/4-20
13	933988	2	PUSHNUT, 5/16 Stud
14	1678811	1	PLATE, Flange
15	1931333	2	CARRIAGE BOLT, 5/16-18 x 3/4
16	1702433	1	FAN ASSY. (5 Blade)
17	918312	1	KEY, Woodruff
18	1960288	1	CARRIAGE BOLT, 3/8-16 x 1-1/4
19	1928731	3	NUT, Hex Jam Lock, 3/8-16
20	1702554	1	PLATE, Shroud
21	170397	1	STOP, Belt
22	1919328	1	WASHER, Plain, 11/32
23	1960104	2	CAPSCREW, Hex, Thin Hd., 5/16-18 x 3/4
24	1702563	1	BUSHING
25	1928691	1	SET SCREW, Socket Hd., 5/16-18 x 3/8
26	1702685	1	PULLEY, Driven
27	1666114	1	SPACER
28	1921969	1	CAPSCREW, Hex, 3/8-16 x 1-1/2
29	1679554	1	SPRING, Tension
30	174561	1	PULLEY, Idler
31	1701827	1	IDLER ARM ASSY.
32	1921210	1	CAPSCREW, 3/8-16 x 1
33	157424	1	WASHER, Special
34	1935945	4	SCREW, Truss Hd, 1/4-20 x 3/4
35	1666294	1	SPACER
36	1708030	1	PULLEY, Idler
37	1676435	1	WASHER, Plain, 1/2
38	1702589	1	COVER, Top
39	1921319	2	WASHER, Plain, 9/32
40	1917356	1	WASHER, Spring
41	1917372	1	NUT, Hex, 5/16
42	1924940	5	WASHER, 13/32

## SAFETY DECAL

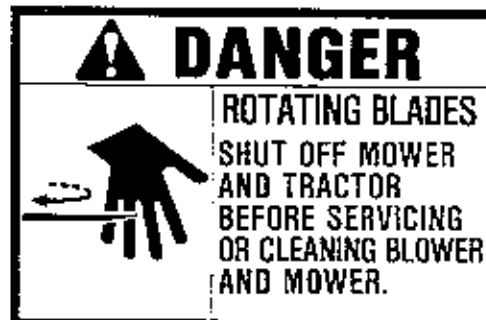

Ref. No. 9



## 60" Turbo Collection System - Blower Group

Ref. No.	Part No.	Qty.	Description
1	1679912	1	MOUNTING PLATE, 60"
2	1921959	15	SCREW, Hex Hd., 1/4-20 x 5/8
3	1960346	1	CAPSCREW, Hex, 1/4-20 x 2-1/4
4	1700936	1	STOP, Deflector
5	1924009	1	CAPSCREW, Hex, 1/4-20 x 7/8
6	1927557	6	NUT, Flange, Lock, 5/16-18
7	1665982	4	BEARING, Retainer
8	108202	2	BEARING
9	1700259	1	DECAL, Warning
10	1706718	1	TURBO HOUSING, (Incl. Ref. No. 9)
11	1679900	1	HOOK, Stoneguard
12	1930641	17	NUT, Hex Flange Whiz, 1/4-20
13	933988	6	PUSH NUT, Nylon, 1/4-20
14	1676435	1	WASHER, Plain, 1/2
15	1931333	7	CARRIAGE BOLT, 5/16-18 x 3/4
16	1706631	1	FAN ASSY. (5 Blade)
17	960403	1	KEY, Woodruff
18	1960268	1	CARRIAGE BOLT, 3/8-16 x 1-1/4
19	1928731	3	NUT, Hex Jam Lock, 3/8-16
20	1706652	1	PLATE, Shroud
21	170397	1	STOP, Belt
22	1919326	1	WASHER, Plain, 11/32
23	1702589	1	COVER, Top
24	1924940	5	WASHER, 13/32
25	1928691	1	SETSCREW, Sq. Hd., 5/16-18 x 3/8
26	1706634	1	PULLEY, Driven
27	1666114	1	SPACER
28	1921969	1	CAPSCREW, Hex Hd., 3/8-16 x 1/2
29	1679554	1	SPRING, Tension
30	174561	1	PULLEY, Idler, Adjustable
31	1701827	1	IDLER ARM ASSY.
32	1921210	1	CAPSCREW, 3/8-16 x 1
33	157424	1	WASHER, Special
34	1917356	1	LOCKWASHER, 5/16
35	1917372	1	NUT, Hex, 5/16
36	1708030	1	PULLEY, Idler,
37	1923341	2	CAPSCREW, Hex Hd., 1/4-20 x 3/4

## SAFETY DECAL

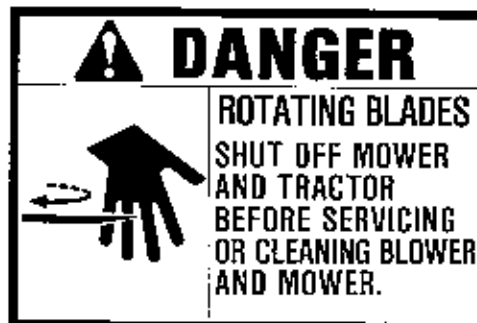

Ref. No. 9

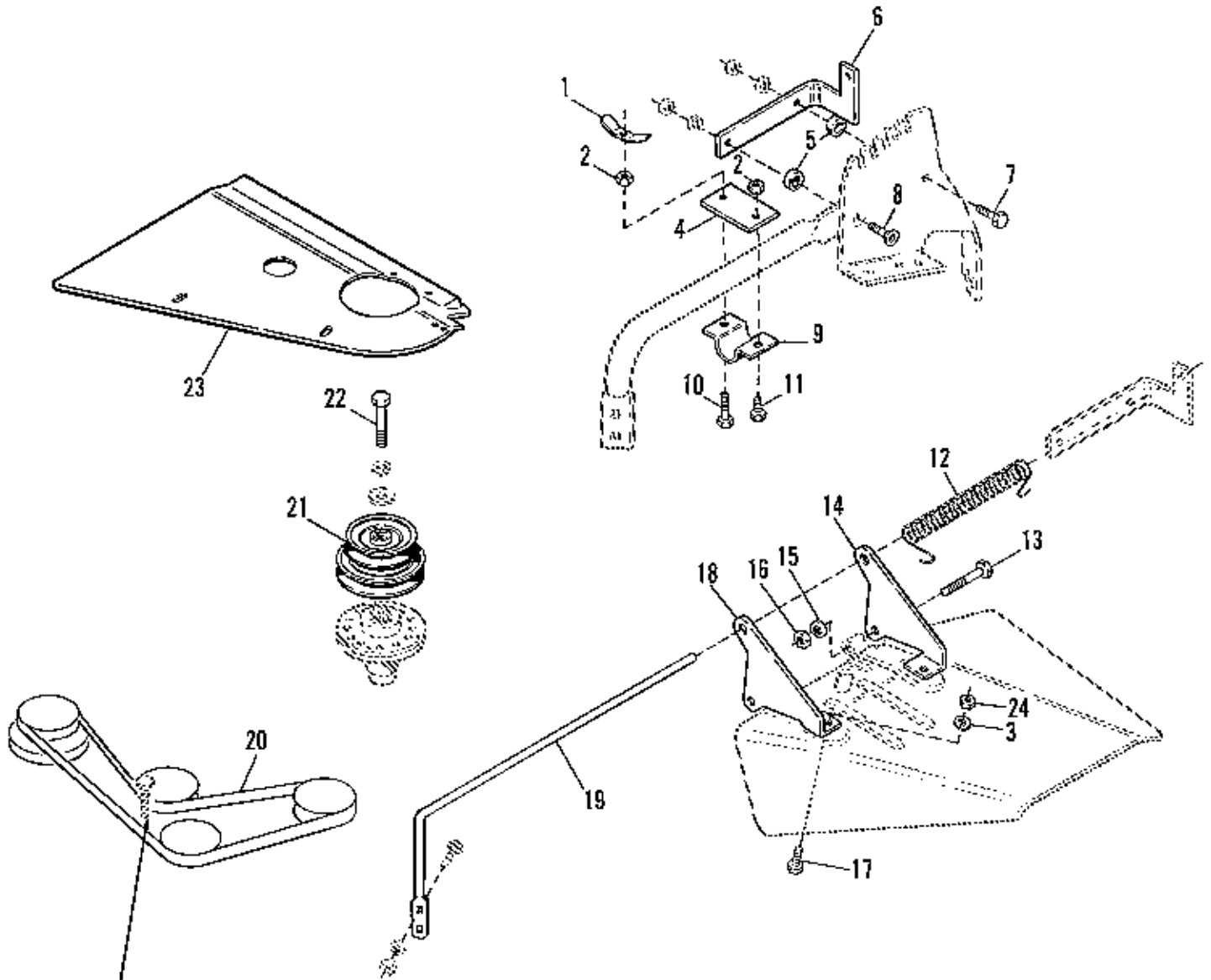

NOTE: For installation & operational purposes, belt (Ref. No. 27) must be installed to the **outboard** side of cap screw (see Ref. No. 3, page 76) as shown.

NOTE: Use standard hardware torque spec. chart unless otherwise noted.



## 42" Turbo Collection System - Cover &amp; Support Group

Ref. No.	Part No.	Qty.	Description
1	1702157	1	WING NUT
2	1928698	2	NUT, Hex Jam Lock, 5/16-18
3	1917356	2	LOCKWASHER, 5/16
4	1679899	1	CLAMP, Upper
5	1666697	2	SPACER
6	1700797	1	PIVOT ASSY., Deflector
7	1921977	1	CAPSCREW, Hex, 5/16-18 x 1-1/4 (1691257 only)
	1922127	1	CAPSCREW, Hex, 5/16-18 x 1-3/4 (1691607 & 1692002 only)
8	1700850	1	SCREW, Flat Hd., Hex Soc., 5/16-18 1-3/4
9	1679898	1	CLAMP, Lower
10	1921977	1	CAPSCREW, Hex Hd., 5/16-18 x 1-1/4
11	1925205	1	CAPSCREW, Hex Hd., 5/16-18 x 5/8
12	1700852	1	SPRING, Torsion
13	1926109	2	CAPSCREW, Hex Hd., 7/16-14 x 2-1/4 (1691257 & 1691607 only)
	1926110	2	CAPSCREW, Hex Hd., 7/16-14 x 2-3/4 (1692002 only)
14	1700802	1	PIVOT, Bracket, R.H.
15	1918199	2	LOCKWASHER, 7/16
16	1918213	2	NUT, Hex, Full, 7/16-14
17	1923325	2	CAPSCREW, Hex, 5/16-18 x 7/8
18	1700801	1	PIVOT, Bracket, L.H.
19	1700846	1	ROD, Hinge
20	1679913	1	V-BELT
21	1679904	1	PULLEY ASSY. (Arbor)
22	1927120	1	CAPSCREW, Hex Hd., 7/16-14 x 2-1/4
23	1700012	1	COVER, L.H., Mower
24	1917372	2	NUT, Hex, Full, 5/16-18

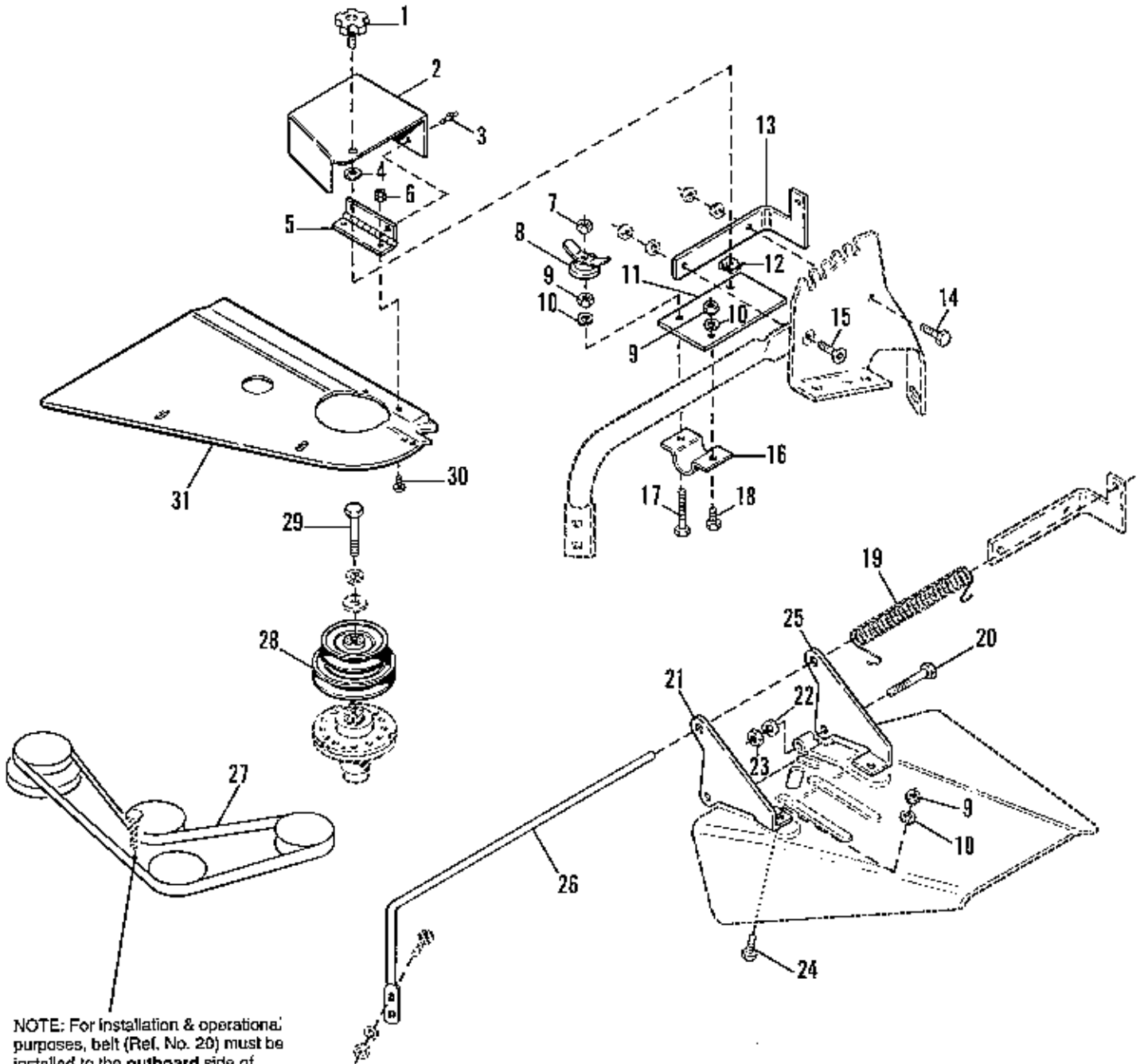

NOTE: For installation & operational purposes, belt (Ref. No. 20) must be installed to the **outboard** side of cap screw (see Ref. No. 3, page 76) as shown.

NOTE: Use standard hardware torque spec. chart unless otherwise noted.

## 48" Turbo Collection System - Cover &amp; Support Group

Ref. No.	Part No.	Qty.	Description
1	1700669	1	PLASTIC KNOB
2	1700728	1	COVER ASSY.
3	928707	2	RIVET
4	933988	1	PUSH NUT, 5/16
5	1700649	1	HINGE
6	1928919	2	NUT, Hex Washer, #10-32
7	1923362	1	NUT, Hex Full Lock, 5/16-18
8	1679163	1	WING NUT ASSY.
9	1917372	4	NUT, Hex Full, 5/16-18
10	1917356	4	LOCKWASHER, 5/16
11	1700638	1	CLAMP, Upper
12	935255	1	PAL NUT, 5/16-18
13	1700797	1	PIVOT ASSY., Deflector
14	1921977	1	CAPSCREW, Hex, 5/16-18x 1-1/4
15	1700849	1	SCREW, Flat Hd., Hex Soc., 5/16-18
16	1679898	1	CLAMP, Lower
17	1960318	1	CAPSCREW, Hex Hd., 5/16-18 x 2-1/2
18	1925205	1	CAPSCREW, Hex Hd., 5/16-18 x 5/8
19	1700851	1	SPRING, Torsion
20	1926109	2	CAPSCREW, Hex Hd., 7/16-14 x 2-1/4 (1691258 & 1691606 only)
	1696110	2	CAPSCREW, Hex Hd., 7/16-14 x 2-3/4 (1692003 only)
21	1700801	1	PIVOT, Bracket, L.H.
22	1918199	2	LOCKWASHER, 7/16
23	1918213	2	NUT, Hex, Full, 7/16-14
24	1923325	2	CAPSCREW, Hex, 5/16-18 x 7/8
25	1700802	1	PIVOT, Bracket, R.H.
26	1700800	1	ROD, Hinge
27	1679914	1	V-BELT
28	1679903	1	PULLEY ASSY. (Arbor)
29	927120	1	CAPSCREW, Hex Hd., 7/16-14 x 2-1/4
30	922121	2	SCREW, Rd. Hd., Mach., #10-32 x 3/8
31	1700013	1	COVER, L.H., Mower

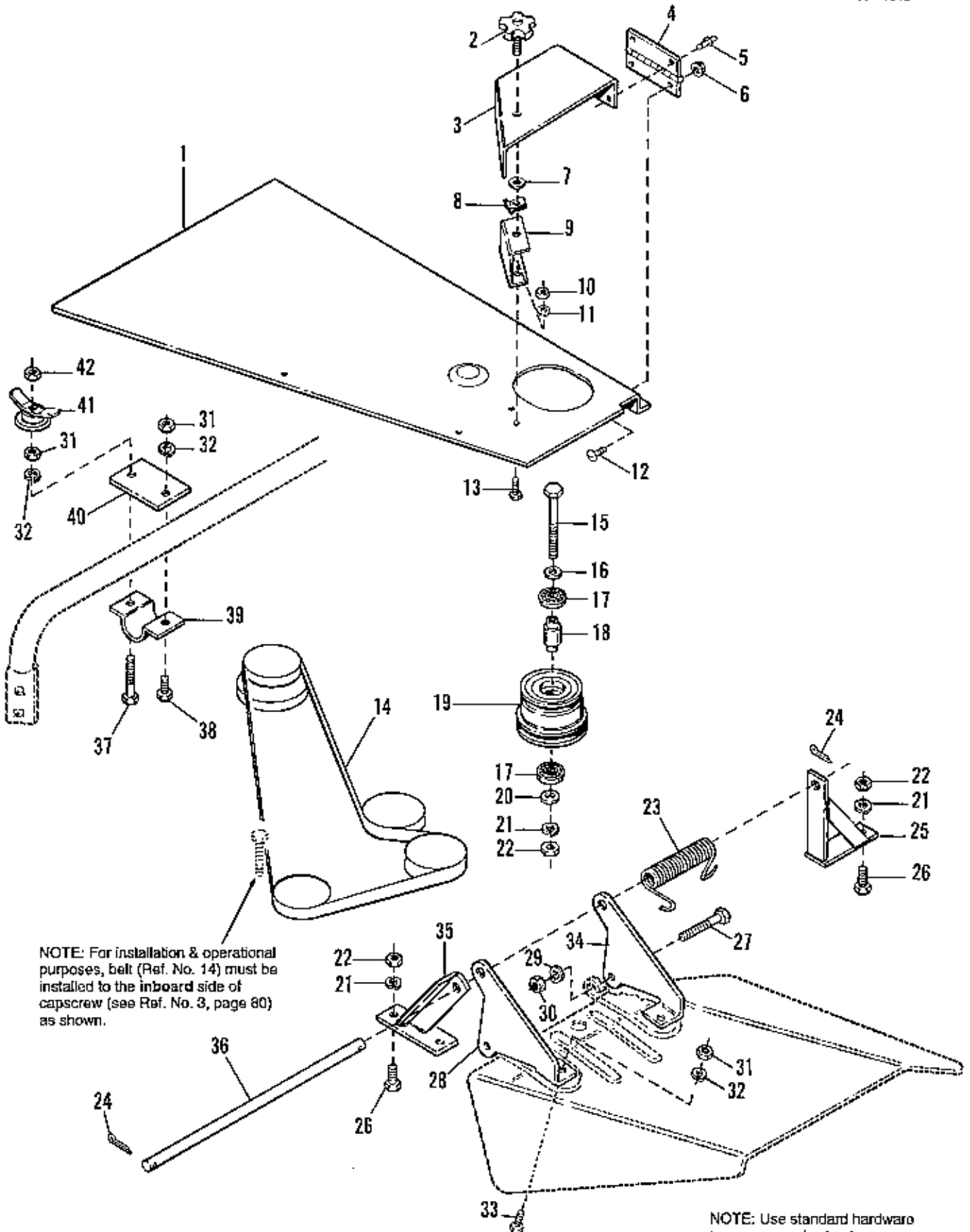

NOTE: For installation & operational purposes, belt (Ref. No. 14) must be installed to the inboard side of capscrew (see Ref. No. 3, page 80) as shown.

NOTE: Use standard hardware torque spec. chart unless otherwise noted.

## 60" Turbo Collection System - Cover &amp; Support Group

Ref. No.	Part No.	Qty.	Description
1	1700647	1	COVER, L.H. Mower
2	1700669	1	PLASTIC KNOB
3	1700668	1	COVER ASSY., (Incl. Ref. Nos. 4 & 5)
4	1700649	1	HINGE
5	928707	2	RIVET, 3/16 x 5/16
6	1928919	2	NUT, Hex, Washer #10-32
7	933988	1	PUSH NUT, 5/16 Stud
8	935255	1	PALNUT, 5/16-18
9	1700654	1	BRACKET, Belt Cover
10	1916622	2	NUT, Hex, Full, 1/4-20
11	1916964	2	LOCKWASHER, 1/4
12	922121	2	SCREW, Rd. Hd., Mach., #10-32 x 3/8
13	1921958	2	CAPSCREW, Hex, 1/4-20 x 1/2
14	1679915	1	V-BELT
15	1922918	1	SCREW, Cap, Hex, 3/8-16 x 3-1/4
16	157424	1	WASHER, Special
17	1705897	2	BEARING
18	1700651	1	SPACER, Pulley
19	1700650	1	PULLEY
20	1700652	1	SPACER
21	1916965	3	LOCKWASHER, 3/8
22	1916950	3	NUT, Hex, Full, 3/8-16
23	1700852	1	SPRING, Torsion
24	1918447	2	PIN, Cotter, 3/32 x 3/4
25	1700832	1	HINGE ASSY., Rear
26	1921210	2	CAPSCREW, Hex, 3/8-16 x 1
27	1926109	2	CAPSCREW, Hex, 7/16-14 x 2-1/4
28	1700801	1	PIVOT, Bracket, L.H.
29	1918199	2	LOCKWASHER, 7/16
30	1918213	2	NUT, Hex, Full, 7/16-14
31	1917372	4	NUT, Hex, Full, 5/16-18
32	1917356	4	LOCKWASHER, 5/16
33	1923325	2	CAPSCREW, Hex, 5/16-18 x 7/8
34	1700802	1	PIVOT, Bracket, R.H.
35	1700828	1	HINGE ASSY., Front
36	1700853	1	ROD, Pivot
37	1960318	1	CAPSCREW, Hex, 5/16-18 x 2-1/2
38	1925205	1	CAPSCREW, Hex, 5/16-18 x 5/8
39	1679898	1	CLAMP, Lower
40	1679899	1	CLAMP, Upper
41	1679163	1	NUT ASSY.
42	1923362	1	NUT, Hex, Full, Lock, 5/16-18

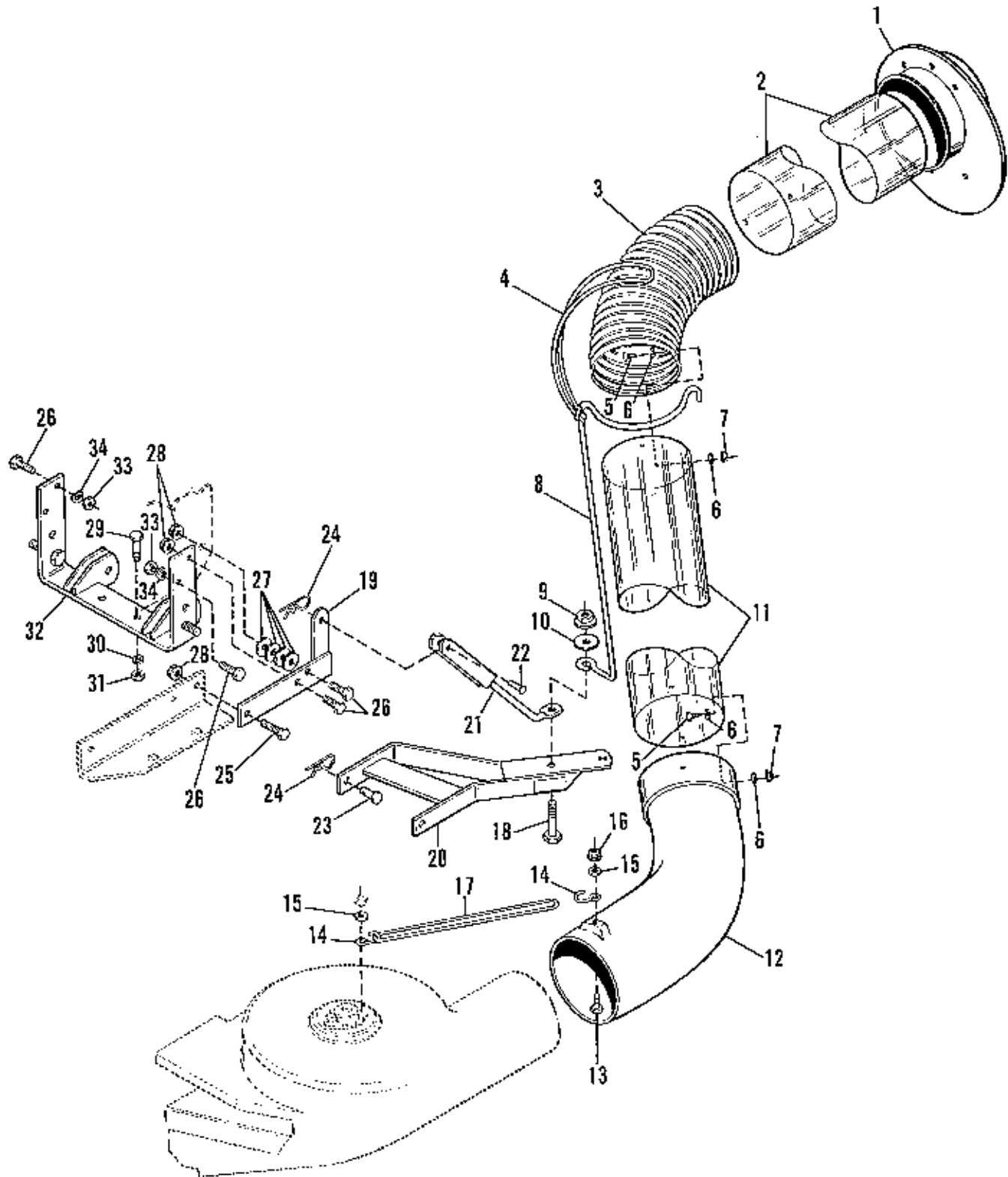

NOTE: Use standard hardware torque spec. chart unless otherwise noted.

## Turbo Hose &amp; Hitch Group

Ref. No.	Part No.	Qty.	Description
1	1703147	1	CONNECTOR, Cart (7.0" Dia.)
2	1702762	1	TUBE
3	1679895	1	HOSE
4	1665872	1	STRAP
5	1930531	12	SCREW, Truss Hd., #10-32 x 1/2
6	1923212	24	WASHER, Plain, #10
7	1928919	12	NUT, Hex, & Washer Assy., #10-32
8	1702517	1	SUPPORT, Tube
9	1930644	1	NUT, Hex, Flange, 1/2-13
10	1926192	1	WASHER
11	1702791	1	TUBE ASSY. (Mfg. No. 1691610) (w/decal*)
	1702792	1	TUBE ASSY. (Mfg. No. 1691609) (w/decal*)
12	1702516	1	ELBOW
13	1925205	1	CAPSCREW, Hex, 5/16-18 x 5/8
14	1702765	2	HOOK
15	1917642	2	WASHER, Plain, 5/16
16	1935048	1	NUT, Flange, Lock, 5/16
17	172744	1	STRAP
18	1921024	1	CAPSCREW, Hex Hd., 1/2-13 x 2
19	1702613	1	SUPPORT ASSY.
20	1702575	1	DRAWBAR ASSY.
21	1702578	1	SUPPORT ASSY., Drawbar
22	155037	1	PIN, Round Hd.
23	1960116	2	PIN, Yoke
24	1960033	3	CLIP, Spring
25	1923027	1	CAPSCREW, Hex Hd., 7/16-14 x 1-3/4
26	1920677	5	CAPSCREW, Hex Hd., 7/16-14 x 1-1/4
27	1924940	4	WASHER, Flat
28	1930650	3	NUT, Flange
29	1921176	2	CAPSCREW, Hex Hd., 1/2-13 x 1-1/4
30	1916968	2	WASHER, Lock, 1/2
31	1916951	2	NUT, Hex, 1/2-13
32	1679731	1	BRACKET ASSY., Hitch
33	1918213	3	NUT, Hex, 7/16-14
34	1918199	3	WASHER, 7/16

\*Ref. No. 11 Includes Part No. 1675766, Qty. 1, of Cleaning Instruction Decal.

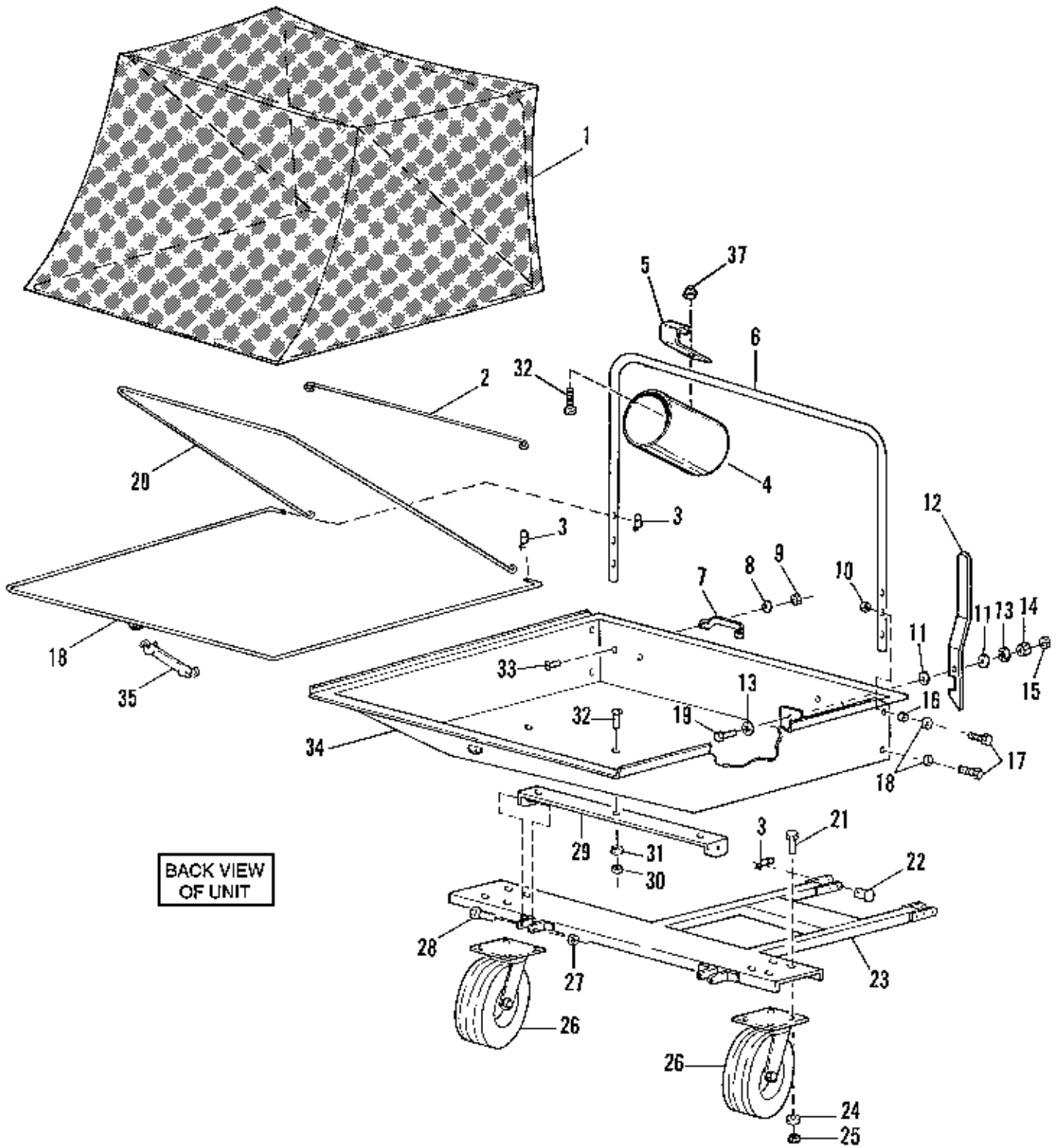

BACK VIEW  
OF UNIT

NOTE: Use standard hardware  
torque spec. chart unless  
otherwise noted.



## Wide Body Cart Collector - Cart Group

Ref. No.	Part No.	Qty.	Description
1	1700760	1	COVER
2	1700763	1	ROD, Straight
3	176012	2	CLIP, Safety, Hairpin
4	1700866	1	SLEEVE, Plastic, Connecting
5	1708097	1	CLAMP, Sleeve
6	1700758	1	TUBE, Support
7	1700768	2	HANDLE, Lift
8	1916964	4	LOCKWASHER, 1/4
9	1916622	4	NUT, Hex, 1/4-20
10	1923362	4	NUT, Lock, 5/16-18
11	1917642	6	WASHER, Flat, 5/16 (1691367 & 1691358)
	1919326	6	WASHER, Flat, 5/16 (1691526 only)
12	1700765	1	HANDLE, Latch
13	177649	2	WASHER, Spring, 5/16
14	1917372	1	NUT, Hex, Full, 5/16-18
15	1920161	1	NUT, Jam, 5/16-18
16	1700267	2	SPACER, Plastic, 5/16
17	1921677	4	CAPSCREW, Hex Hd., 5/16-18 x 1-1/2
18	1700762	1	ROD, Frame
19	1921977	1	CAPSCREW, Hex Hd., 5/16-18 x 1-1/4
20	1700761	1	ROD, Support
21	1921210	8	BOLT, Hex, 3/8-16 x 1
22	102004	2	PIN, 1/2 x 1-1/4
23	1700769	1	FRAME
24	1917378	8	WASHER, Flat, 3/8 S.A.E.
25	1930651	8	NUT, Hex Lock, 3/8-16
26	1676892	2	WHEEL, Swivel, 410/350-4
27	1922134	2	NUT, Hex Lock, 1/2-13
28	1921176	2	CAPSCREW, Hex Hd., 1/2-13 x 1-1/4
29	1700767	1	"U" BRACKET
30	1917372	3	NUT, Hex, 5/16-18
31	1917356	3	LOCKWASHER, 5/16
32	1918249	3	BOLT, Slotted, Truss Hd.
33	1921958	4	CAPSCREW, Hex Hd., 1/4-20 x 1/2
34	1700757	1	BOX
35	1700266	1	STRAP, Rubber, 6"
36	1921958	1	CAPSCREW, 1/4-20 x 1/2
37	1920397	1	NUT, Nylon insert, 1/4-20

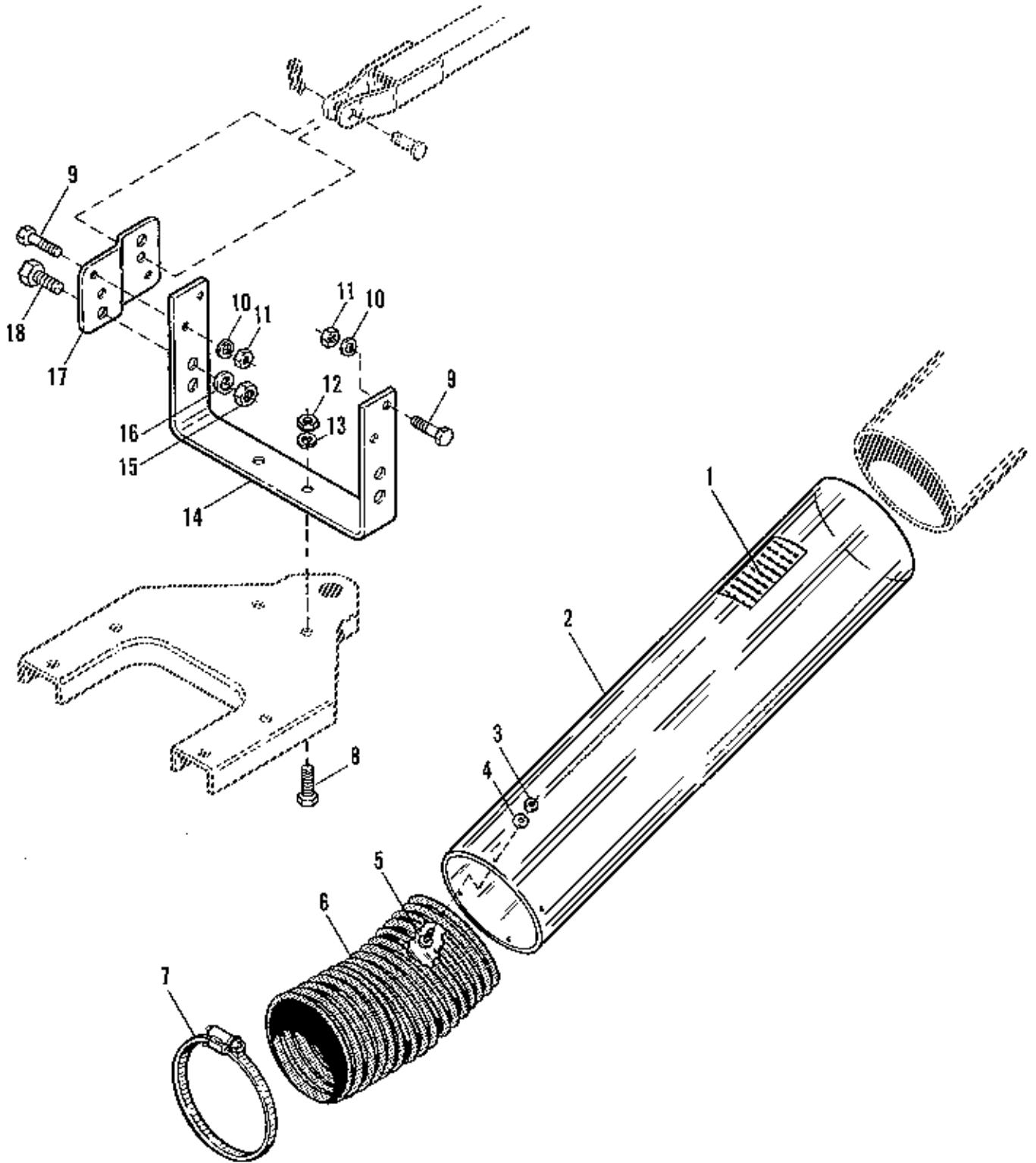

NOTE: Use standard hardware torque spec. chart unless otherwise noted.

## Wide Body Cart Collector - Tube &amp; Hitch Group

Ref. No.	Part No.	Qty.	Description
1	1675766	1	DECAL, Cleaning Inst.
2	1700773	1	TUBE ASSY. (Incl. Ref. No. 1)
3	1930627	4	NUT, Hex, Full, Lock, #10-32
4	1923212	4	WASHER, Plain, #10
5	1930531	4	SCREW, Phillips, Truss Hd., #10-32 x 1/2
6	1679895	1	HOSE
7	1679896	1	CLAMP, 6"
8	1921176	2	CAPSCREW, Hex, 1/2-13 x 1-1/4
9	1921212	4	CAPSCREW, Hex Hd., 7/16-14 x 1-1/2
10	1918199	4	LOCKWASHER, 7/16
11	1918213	4	NUT, Hex, Full, 7/16
12	1916951	2	NUT, Hex, Full, 1/2-13
13	1916966	2	LOCKWASHER, 1/2
14	1675645	1	BRACKET, Hitch (Frame)
15	1915726	2	NUT, Hex, Full, 5/8
16	1917373	2	LOCKWASHER, 5/8
17	1700674	2	BRACKET, Hitch (Cart)
18	1923151	2	CAPSCREW, Hex Hd., 5/8-11 x 1-1/4

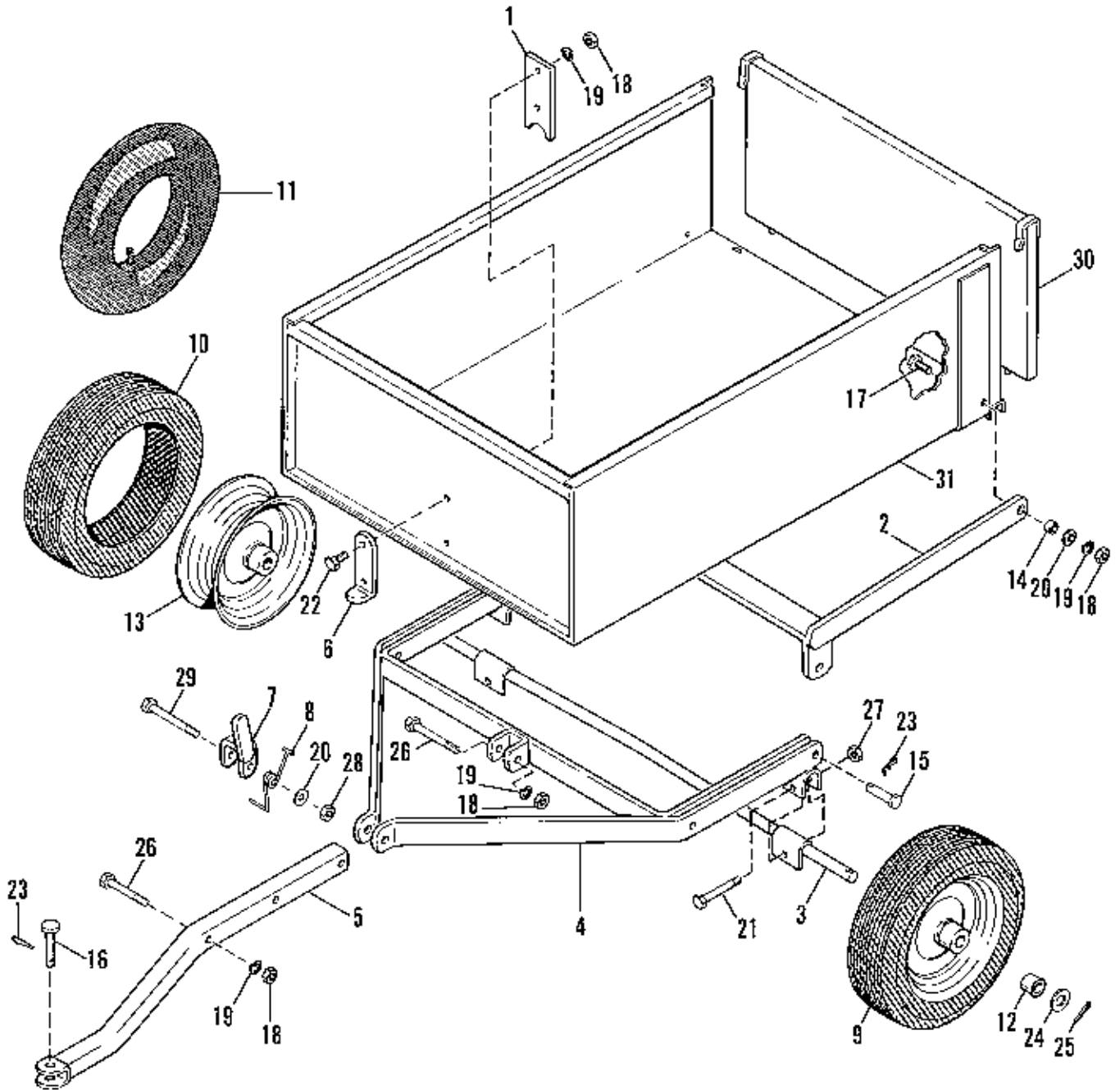

## Dump Cart

Ref. No.	Part No.	Qty.	Description
1	102005	1	PLATE, Box Guide
2	102024	1	PIVOT, Box Assy.
3	102027	1	AXLE ASSEMBLY
4	102035	1	FRAME ASSEMBLY
5	102037	1	TONGUE ASSEMBLY
6	102040	1	PLATE, Box Catch
7	102051	1	CLEVIS ASSEMBLY
8	102075	1	SPRING, Torsion
9	170320	2	WHEEL & TIRE ASSY.
10	102052	2	TIRE
11	153038	2	TUBE, 4.00 x 8
12	156316	4	BEARING
13	170319	2	WHEEL
14	8151076	2	BUSHING
15	102004	2	PIN, Pivot
16	105249	1	PIN
17	921210	2	CAPSCREW, Hex, 3/8-16 x 1
18	1916950	6	NUT, Hex, Full, 3/8-16
19	916965	6	LOCKWASHER, 3/8
20	1917378	3	WASHER, 3/8
21	1921978	2	CAPSCREW, 5/16-18 x 2
22	1920415	2	CAPSCREW, Hex, 3/8-16 x 1-1/4
23	1918196	3	PIN, Quick
24	1918433	2	WASHER, Plain, 3/4
25	1918459	2	PIN, Cotter, 3/16 x 1-1/2
26	1922130	2	CAPSCREW, Hex, 3/8-16 x 2-1/4
27	1923362	2	NUT, Hex, Full, 5/16-18
28	1930651	1	NUT, Hex, Full, 3/8-16
29	1930596	1	CAPSCREW, Hex, 3/8-16 x 2-3/4
30	1668462	1	END GATE ASSY.
31	1668478	1	BODY, Trailer

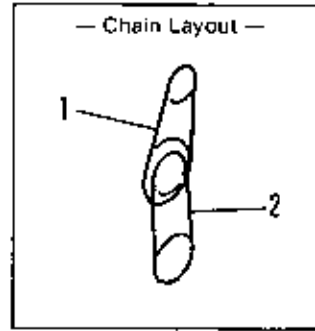

Remove all end play when assembling upper shaft.

Position upper shaft tube for proper chain alignment before tightening clamps.

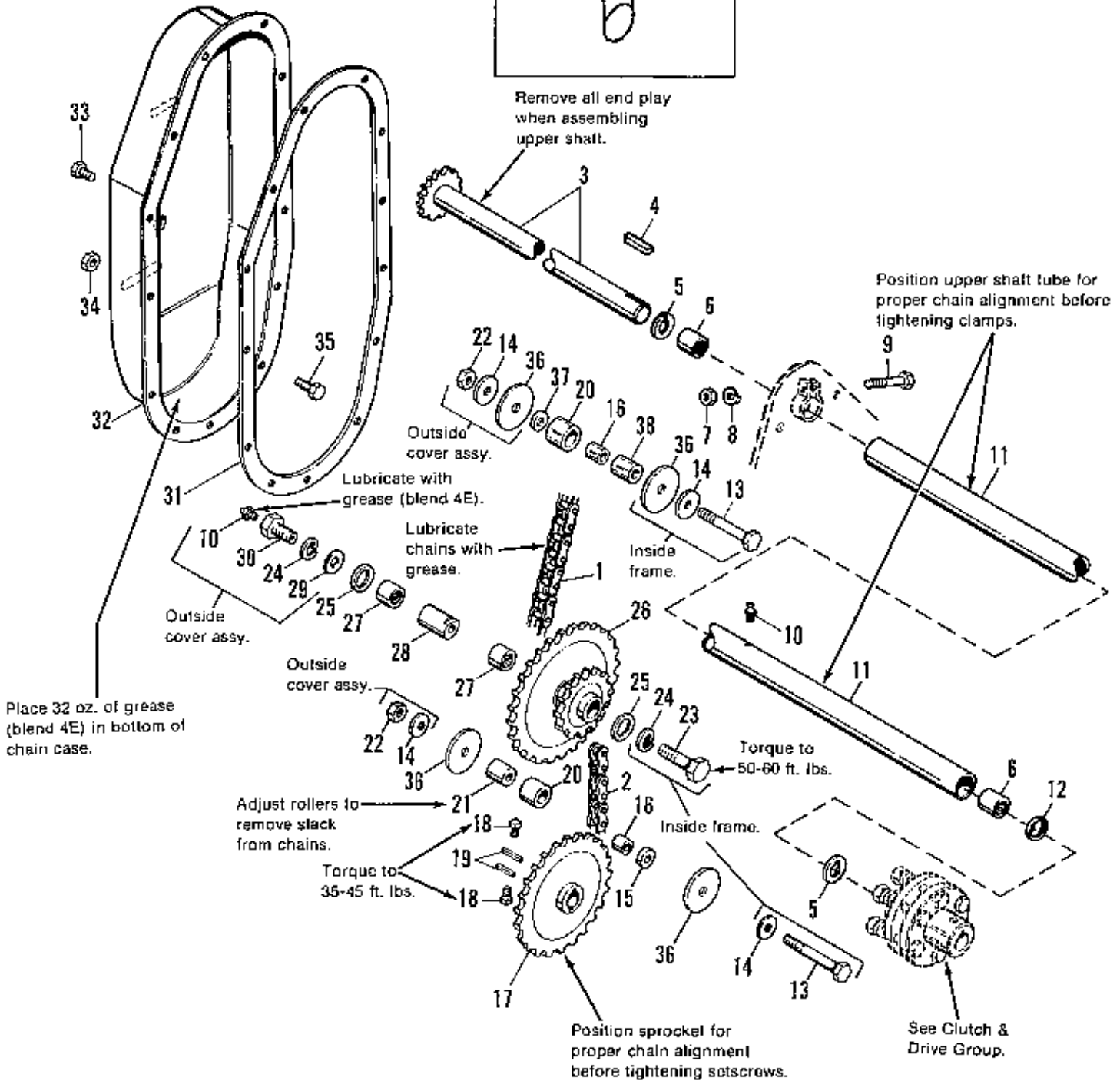

## 38" Tiller - Chain &amp; Cover Group

Ref. No.	Part No.	Qty.	Description
1	172496	1	CHAIN, Roller (upper - 31-1/4") (1690989 only)
	1703624	1	CHAIN, Roller (upper - #50, 27-1/2") (1691735 only)
2	172497	1	CHAIN, Roller (lower - 30")
3	1678856	1	SHAFT & SPROCKET ASSY.
4	905123	1	KEY
5	8061012	2	WASHER
6	172747	2	BEARING, Needle
7	1917372	1	NUT, Hex, Full, 5/16-18
8	1917356	1	LOCKWASHER, 5/16
9	1921221	1	CAPSCREW, Hex, 5/16-18 x 1-1/2
10	912608	2	FITTING, Grease
11	1678855	1	HOUSING ASSY. (Incl. Ref. No. 6 & Ref. No. 12)
12	1669372	1	SEAL, Shaft Assy.
13	1922648	2	CAPSCREW, Hex Hd., 3/8-16 x 4
14	1924356	4	WASHER, Special, 13/32 x 1-1/2
15	172454	1	SPACER
16	170369	2	SPACER, Chain Roller
17	172777	1	SPROCKET ASSY. (Single Gear Plate)
18	1930536	2	SETSCREW, Sq. Hd., 3/8-16 x 3/4
19	172669	2	KEY
20	170177	2	ROLLER, Chain
21	172453	1	SPACER
22	1930651	2	LOCKNUT, Hex, 3/8-16
23	1929528	1	CAPSCREW, Hex Hd., 1/2-20 x 1
24	1916988	2	LOCKWASHER, 1/2
25	8281014	2	WASHER
26	172774	1	SPROCKET ASSY. (2 Gear Plates)
27	105195	2	BEARING
28	172456	1	SPACER
29	1918431	1	WASHER, 1/2
30	105132	1	BOLT, Side R.H.
31	172482	1	GASKET
32	1657551	1	COVER ASSY. (1690989 only)
	1703643	1	COVER ASSY. (1691735 only)
33	1924856	1	SCREW, Hex Tapite, 5/16-18 x 1/2
34	1923362	12	LOCKNUT, Hex, 5/16-18
35	1925205	12	CAPSCREW, Hex Hd., 5/16-18 x 5/8
36	960188	4	WASHER
37	157424	1	WASHER, Special, 3/8 x 1
38	172452	1	SPACER

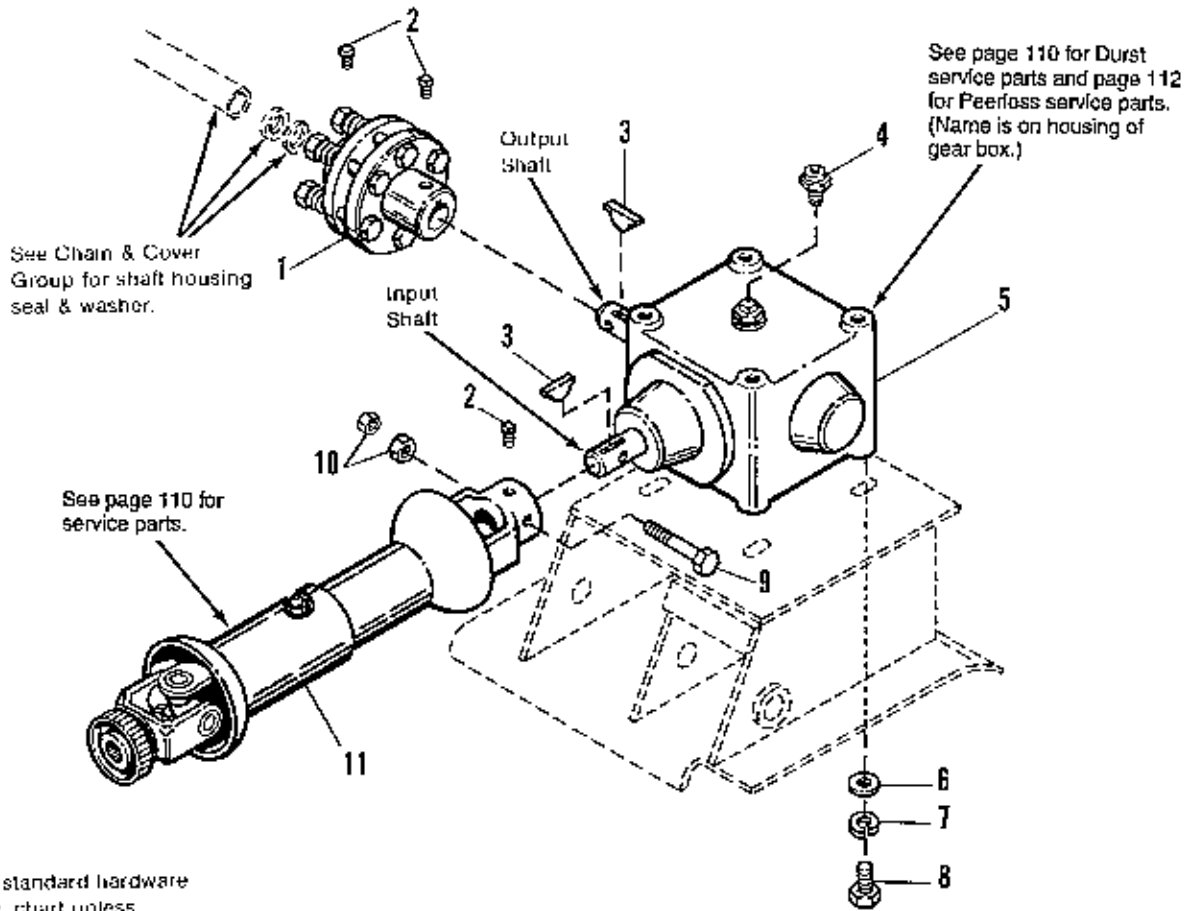

NOTE: Use standard hardware torque spec. chart unless otherwise noted.

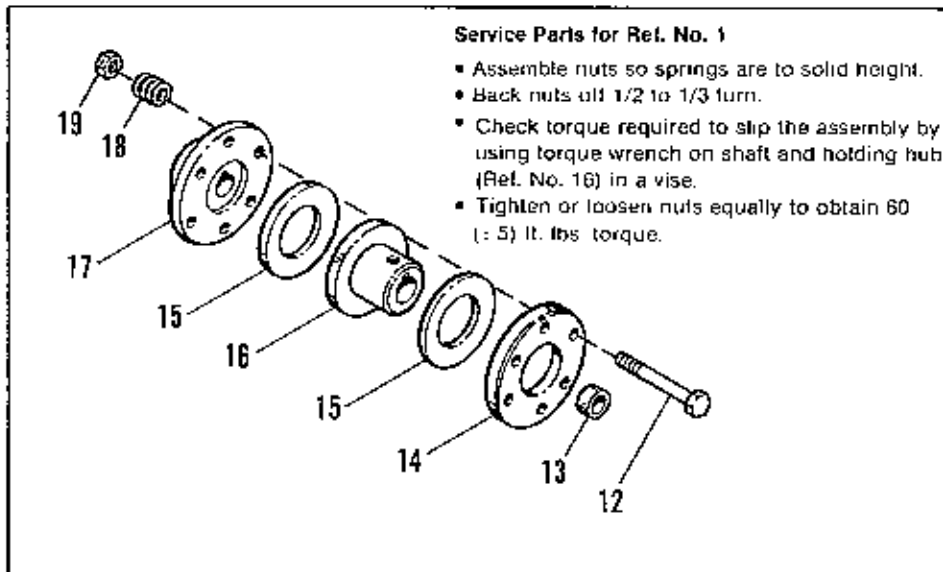



## 38" Tiller - Clutch &amp; Drive Group

Ref. No.	Part No.	Qty.	Description
1	1679678	1	TORQUE LIMITER ASSY. (Incl. Ref. Nos. 12-19)
2	1674333	3	SETSCREW, 5/16-18 x 3/4
3	922138	2	KEY, Hi-Pro, 1/4 x 7/8
4	1678690	1	PLUG, Vent, 1/8-27 NPT
5	1679681	1	DRIVE ASSY., Right Angle (See page 110 for Durst Service Parts & page 112 for Peerless Service Parts.)
6	1924940	4	WASHER, Flat, 3/8 Std.
7	1916965	4	WASHER, Lock, 3/8
8	1921965	4	CAPSCREW, Hex Hd., 3/8-16 x 3/4
9	1925688	1	CAPSCREW, Hex Hd., 1/4-20 x 3
10	1923358	2	NUT, Hexlock, 1/4-20
11	1675387	1	DRIVESHAFT ASSY. (See page 110 for Service Parts.) (1690989 only)
	1703938	1	DRIVESHAFT ASSY. (See page 110 for Service Parts.) (1691735 only)
12	1923141	6	CAPSCREW, Hex Hd., 5/16-18 x 2-3/4
13	1678851	1	BUSHING
14	173327	1	PLATE, Clutch
15	173329	2	DISC, Clutch
16	1679679	1	HUB ASSY. (Incl. Ref. No. 13)
17	1679680	1	HUB, Clutch
18	173575	6	SPRING
19	1923362	6	NUT, Hex, Centerlock, 5/16-18

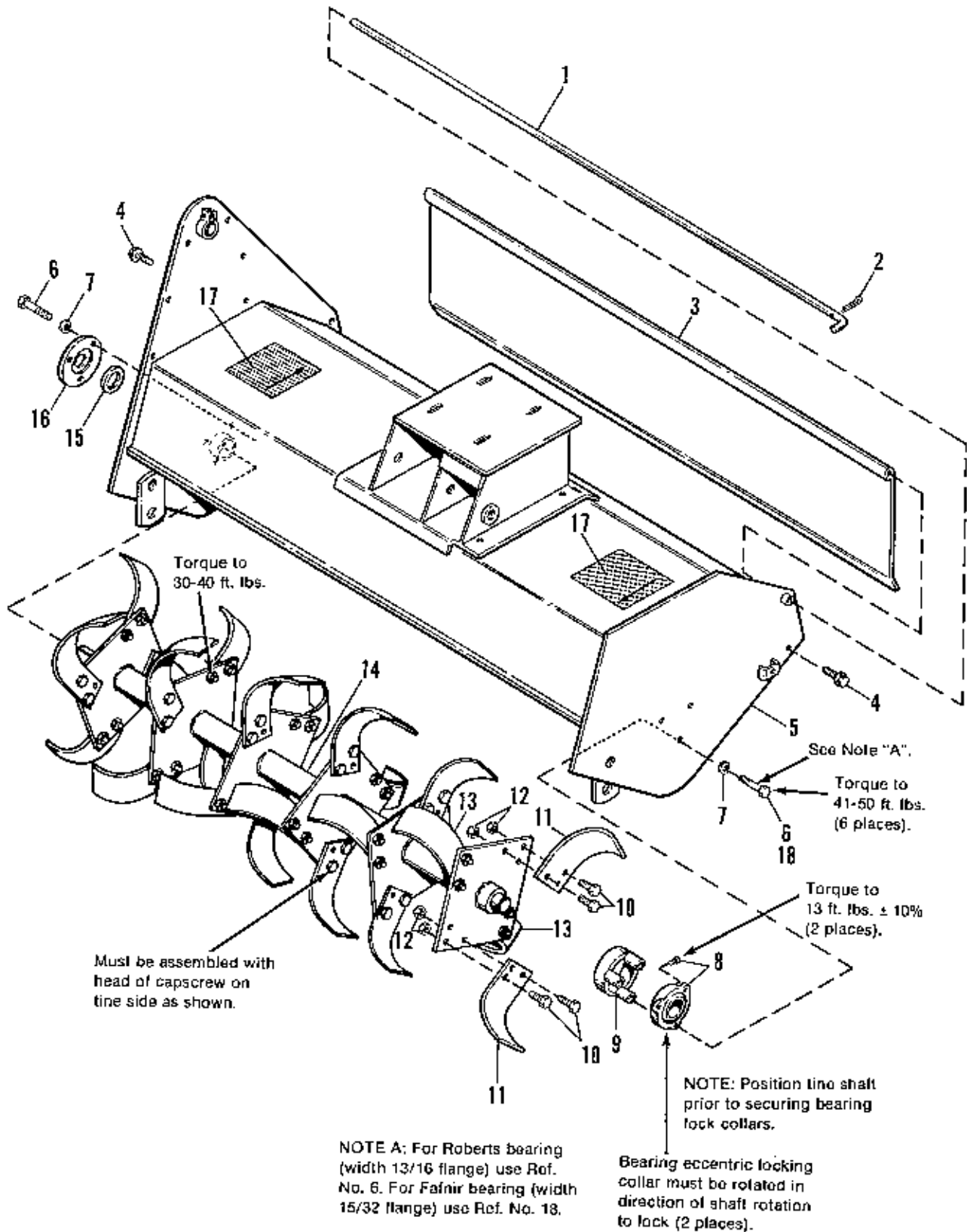

NOTE: Use standard hardware torque spec. chart unless otherwise noted.

## 38" Tiller - Frame, Deflector &amp; Tine Group

Ref. No.	Part No.	Qty.	Description
1	1657389	1	ROD, Deflector
2	1918448	1	PIN, Cotter, 3/32 x 1
3	1657384	1	DEFLECTOR
4	1928635	2	SCREW, Thd. Form., Taptite, 3/8-16 x 1-1/4
5	1685387	1	HOUSING ASSY.
6	1922606	6	CAPSCREW, Hex Hd., 3/8-16 x 1-3/4 (Used with Roberts bearing only)
7	1916965	6	LOCKWASHER, 3/8
8	1685396	2	FLANGE, Bearing Kit (Incl. Ref. No. 9)
9	1703932	2	GUARD ASSY., Trash
10	1925204	48	CAPSCREW, Hex Hd., 3/8-16 x 1
11	172512	12	TINE, L.H.
12	1930645	48	LOCKNUT, Hex, 3/8-16
13	172511	12	TINE, R.H.
14	1657400	1	SHAFT ASSY., Tine
15	172458	1	SEAL
16	172507	1	RETAINER, Seal
17	1679700	2	DECAL, Danger
18	1922605	6	CAPSCREW, Hex Hd., 3/8-16 x 1-1/4 (Used with Fafnir bearing.)

## SAFETY DECAL

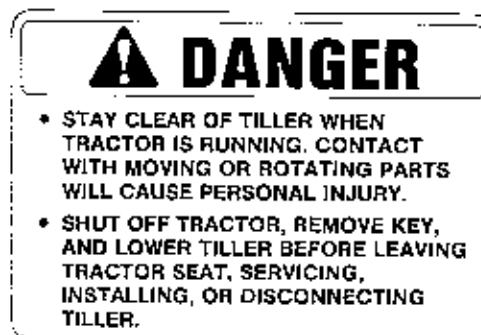

Ref. No. 17

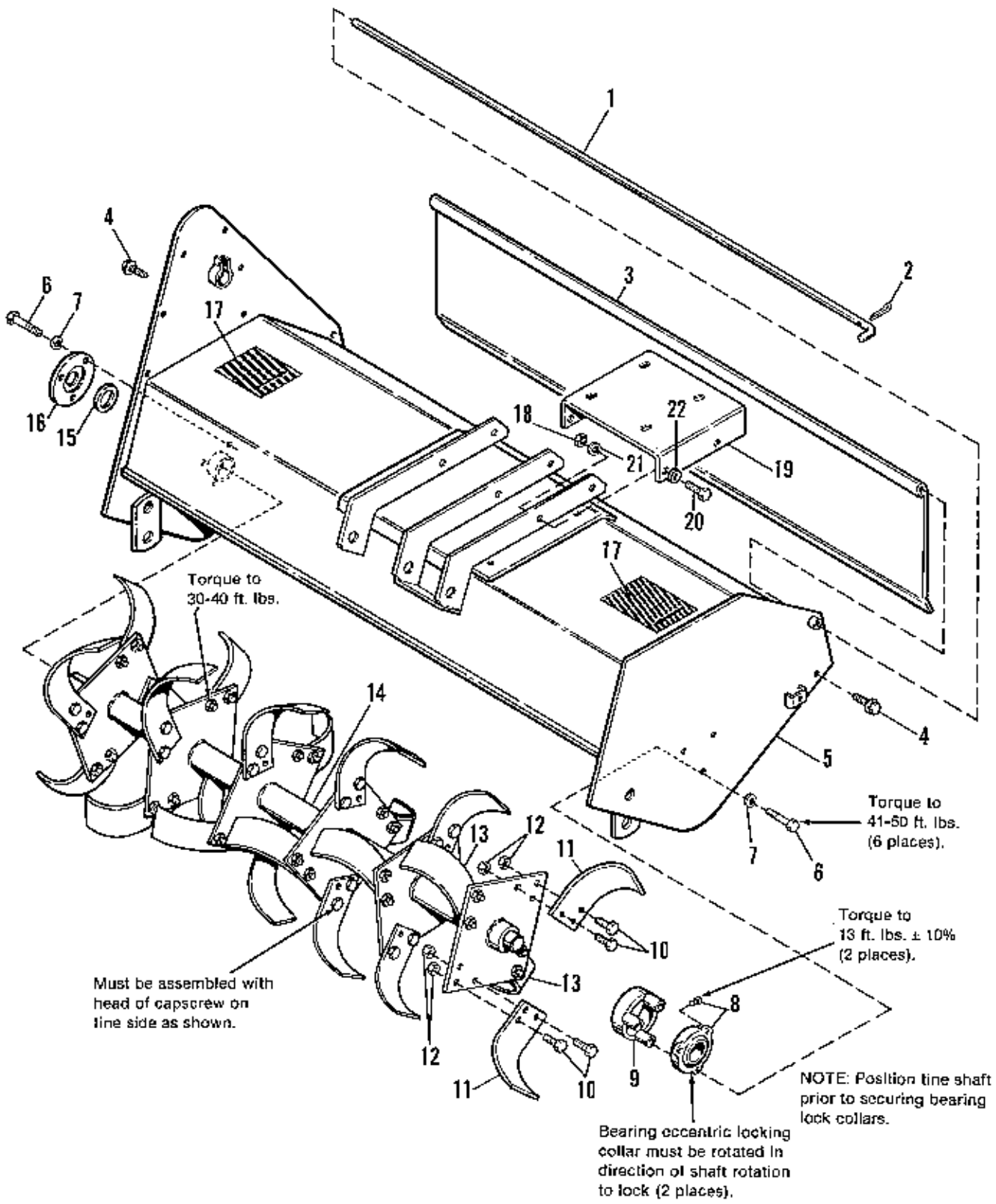

NOTE: Use standard hardware torque spec. chart unless otherwise noted.

Ref. No.	Part No.	Qty.	Description
1	1657389	1	ROD, Deflector
2	1918448	1	PIN, Coller, 3/32 x 1
3	1657384	1	DEFLECTOR
4	1928635	2	SCREW, Thd. Form., Taptito, 3/8-16 x 1-1/4
5	1703628	1	HOUSING ASSY.
6	1922605	6	CAPSCREW, Hex Hd., 3/8-16 x 1-1/4
7	1916965	6	LOCKWASHER, 3/8
8	1704042	2	FLANGE, Bearing
9	1703932	2	GUARD ASSY., Trash
10	1925204	48	CAPSCREW, Hex Hd., 3/8-16 x 1
11	172512	12	TINE, L.H.
12	1930645	48	LOCKNUT, Hex, 3/8-16
13	172511	12	TINE, R.H.
14	1657400	1	SHAFT ASSY., Tine
15	172458	1	SEAL
16	172507	1	RETAINER, Seal
17	1679700	2	DECAL, Danger
18	1916950	4	NUT, 3/8-16
19	1703690	1	SUPPORT, Gear Box
20	1921210	4	CAPSCREW, 3/8-16 x 3/4
21	1916965	4	LOCKWASHER, 3/8
22	1924940	1	WASHER, 13/32

## SAFETY DECAL



Ref. No. 17

NOTE: Use standard hardware torque spec. chart unless otherwise noted.

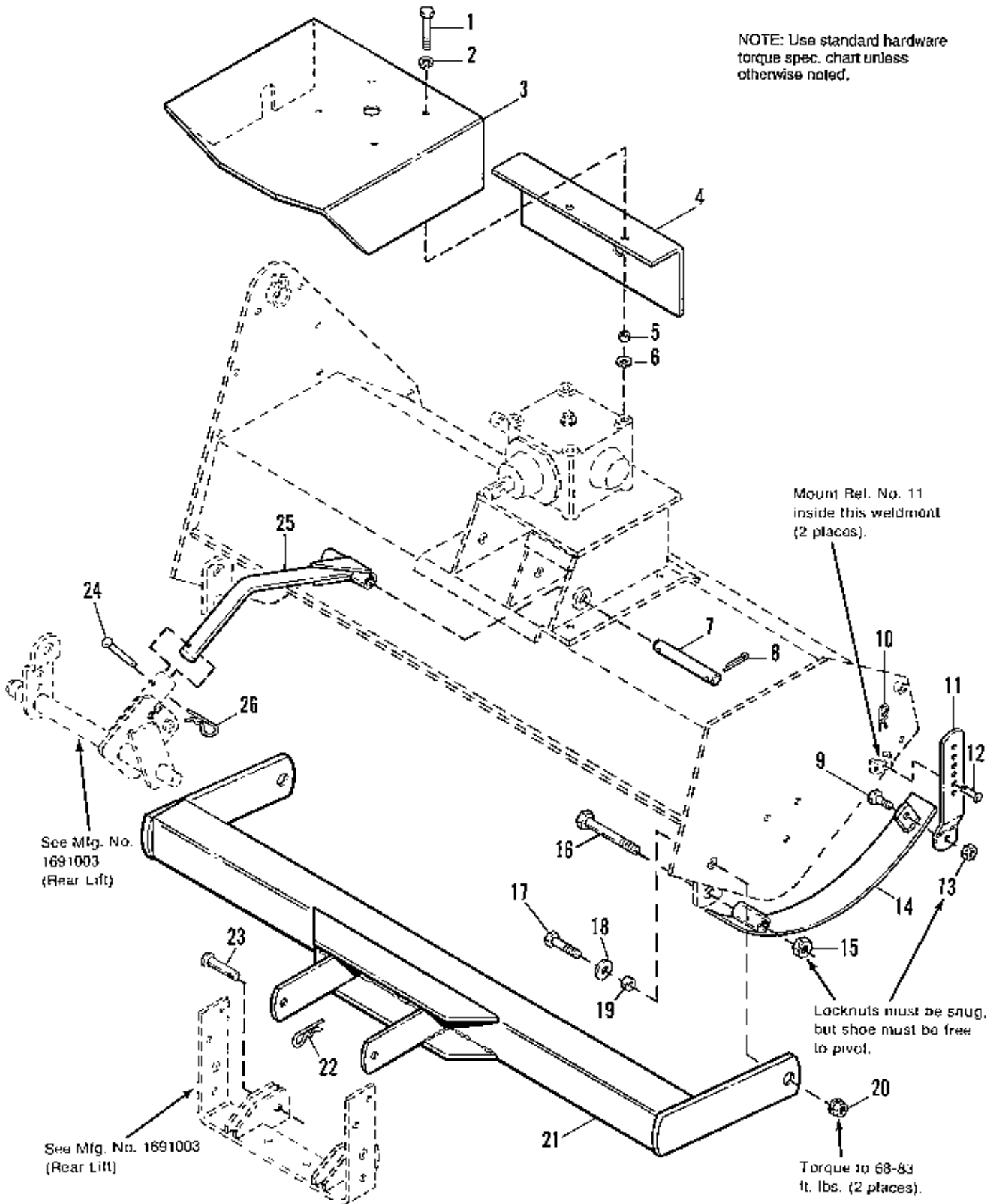

## 38" Tiller - Hitch &amp; Lift Group

Ref. No.	Part No.	Qty.	Description
1	1921971	4	CAPSCREW, Hex Hd., 3/8-16 x 1-3/4
2	1916965	4	WASHER, Lock Spring
3	1679428	1	SHIELD, Gear Box, Top
4	1679427	1	SHIELD, Gear Box, Back
5	1701787	4	SPACER
6	931942	4	NUT, Push Pal, 1-3/8
7	1678547	1	PIN, Pivot
8	1919314	2	PIN, Colter
9	1921210	2	CAPSCREW, Hex Hd., 3/8-16 x 1
10	1918196	2	PIN, Quick, 1-7/8
11	172879	2	BRACKET, Adjusting
12	1923087	2	PIN, Yoke, 3/8
13	1930651	2	LOCKNUT, Hex, 3/8-16
14	172875	2	SKID ASSY.
15	1923353	2	LOCKNUT, Hex, 5/8-11
16	1960289	2	CAPSCREW, Hex Hd., 5/8-11 x 3
17	1920328	2	CAPSCREW, Hex Hd., 1/2-13 x 1-1/2
18	1926192	2	WASHER, Plain, 1/2 x 1-1/4
19	105386	2	SPACER
20	1930644	2	NUT, Lock Flange, 1/2-13
21	1678842	1	HITCH ASSY., 38" Tiller
22	1960033	2	CLIP, Spring
23	1960116	2	PIN, Yoke
24	118053	1	PIN
25	1678844	1	LIFT BAR ASSY. (1690989)
	1703598	1	LIFT BAR ASSY. (1691735)
26	1960074	1	CLIP, Hair Pin, 3/32 x 1-5/8

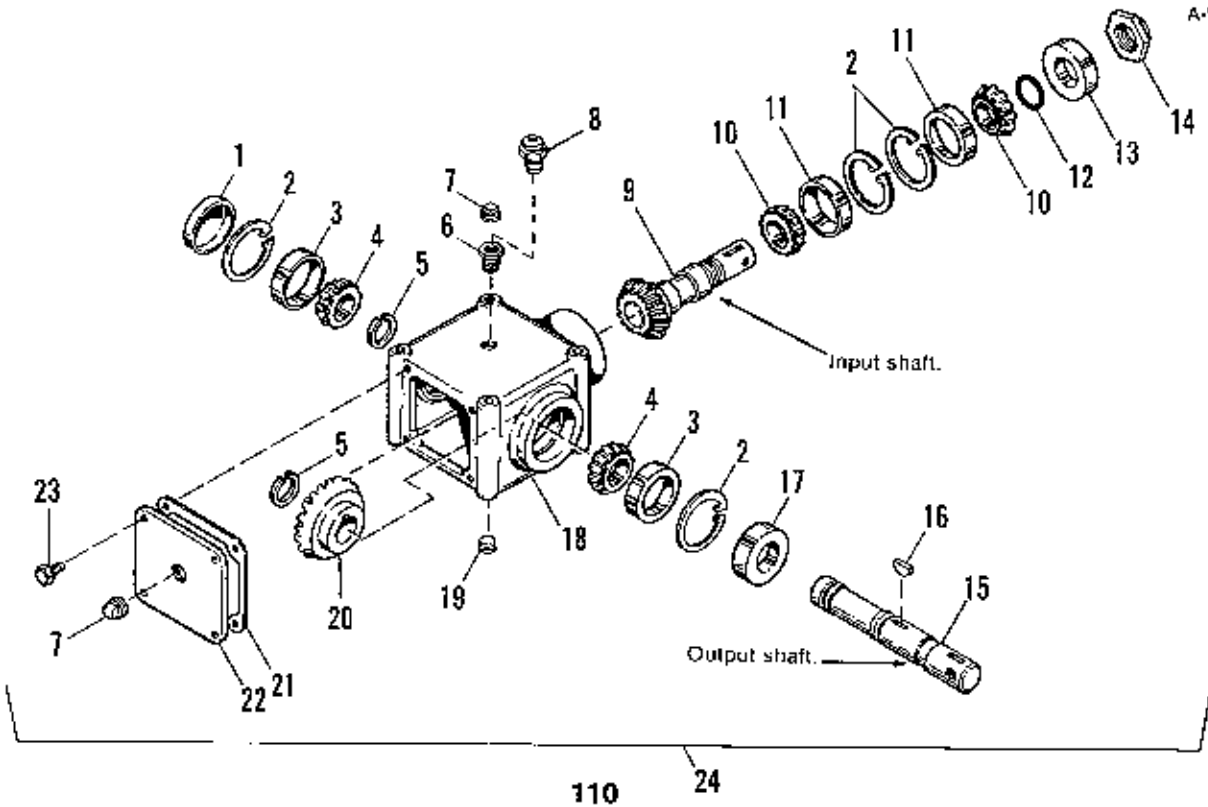
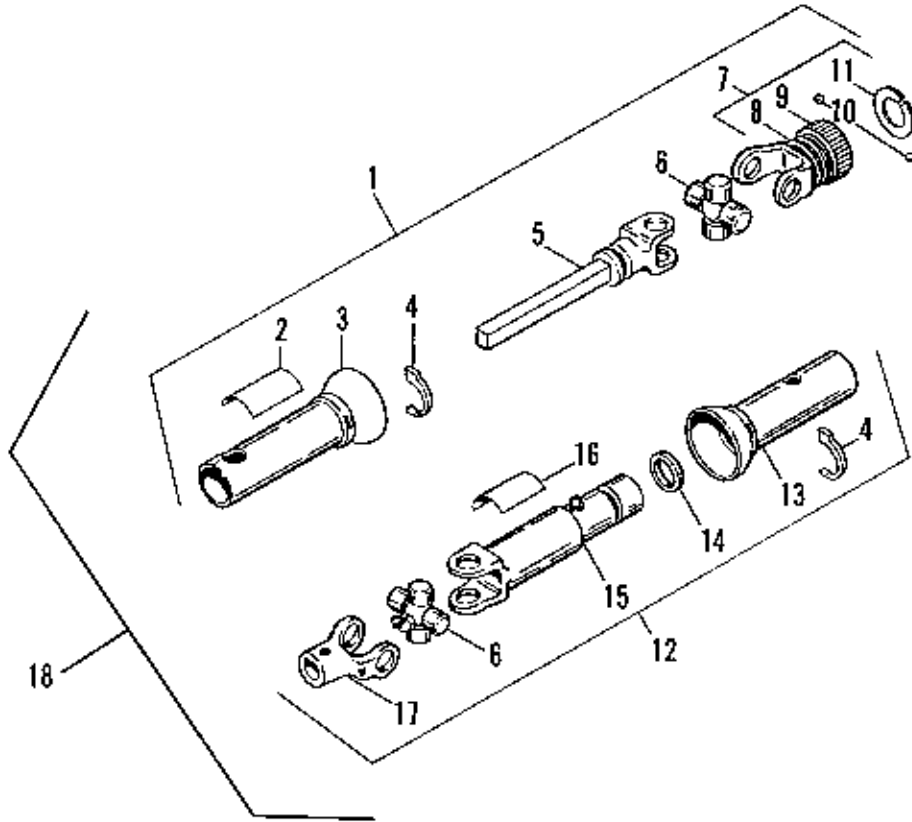



## 38" Tiller - Drive Shaft

Ref. No.	Part No.	Qty.	Description
1	* 1678821	1	DRIVE SHAFT ASSY. - TRACTOR HALF (1690989)
	* 1703943	1	DRIVE SHAFT ASSY. - TRACTOR HALF (1691735)
2	1679461	2	SHIELD DECAL, Outer Shield
3	1685392	1	SHIELD, Outer (1690989)
	1703941	1	SHIELD, Outer (1691735)
4	1679459	4	BEARING
5	1678822	1	YOKE & SHAFT ASSY. (1690989)
	1703942	1	YOKE & SHAFT ASSY. (1691735)
6	1678805	2	JOURNAL ASSY.
7	1678801	1	YOKE ASSY. (Incl. Ref. Nos. 8 - 11)
8	1702432	1	SPRING
9	1678802	1	SLIDELOCK
10	1678804	2	BALL
11	1679531	1	SNAP RING
12	** 1678823	1	DRIVE SHAFT ASSY. - IMPLEMENT HALF (1690989)
	* 1703940	1	DRIVE SHAFT ASSY. - IMPLEMENT HALF (1691735)
13	1685393	1	SHIELD, Inner (1690989)
	1703944	1	SHIELD, Inner (1691735)
14	1679460	1	NYLON BEARING
15	1678824	1	YOKE & TUBE ASSY. (1690989)
	1703939	1	YOKE & TUBE ASSY. (1691735)
16	1678829	1	DANGER LABEL
17	1678807	1	YOKE
18	1675387	1	ASSY., Complete (1690989)
	1703938	1	ASSY., Complete (1691735)

\* Incl. Ref. Nos. 2, 3, Qty. 2 of 4, Qty. 1 of 6, 7 - 11.

\*\* Incl. Ref. Nos. Qty. 2 of 4, Qty. 1 of 6, 13 - 17.

## 38" Tiller - Durst Gear Box

Ref. No.	Part No.	Qty.	Description
1	173593	1	CAP
2	927700	4	SNAP RING
3	170836	2	BEARING, Cup
4	170835	2	BEARING, Cone
5	927320	2	SNAP RING, Output
6	1678933	1	REDUCTION BUSHING, 1/8 - 3/8
7	1668971	2	PLUG, 1/8-27, N.P.T.F.
8	1678690	1	PLUG, Vent, 1/8 x 27 N.P.T.
9	1679687	1	GEAR W/SHAFT, Pinion - 16T
10	1679696	2	BEARING, Cone
11	1679695	2	BEARING, Cup
12	1679692	1	"O" RING
13	1679690	1	SEAL, Input
14	1679688	1	NUT, Stake, Input, 1-1/8-18
15	1679689	1	SHAFT, Output
16	1678931	1	KEY, Woodruff
17	1679691	1	SEAL, Output
18	173586	1	HOUSING
19	930674	1	PLUG, Drain, 3/8-18 N.P.T.F.
20	1679686	1	GEAR, Bevel - 32T
21	173596	1	GASKET, Cover
22	1678903	1	COVER
23	1925205	4	CAPSCREW, Hex Hd., 5/16-18 x 5/8
24	1679681	1	DRIVE ASSY., Right Angle

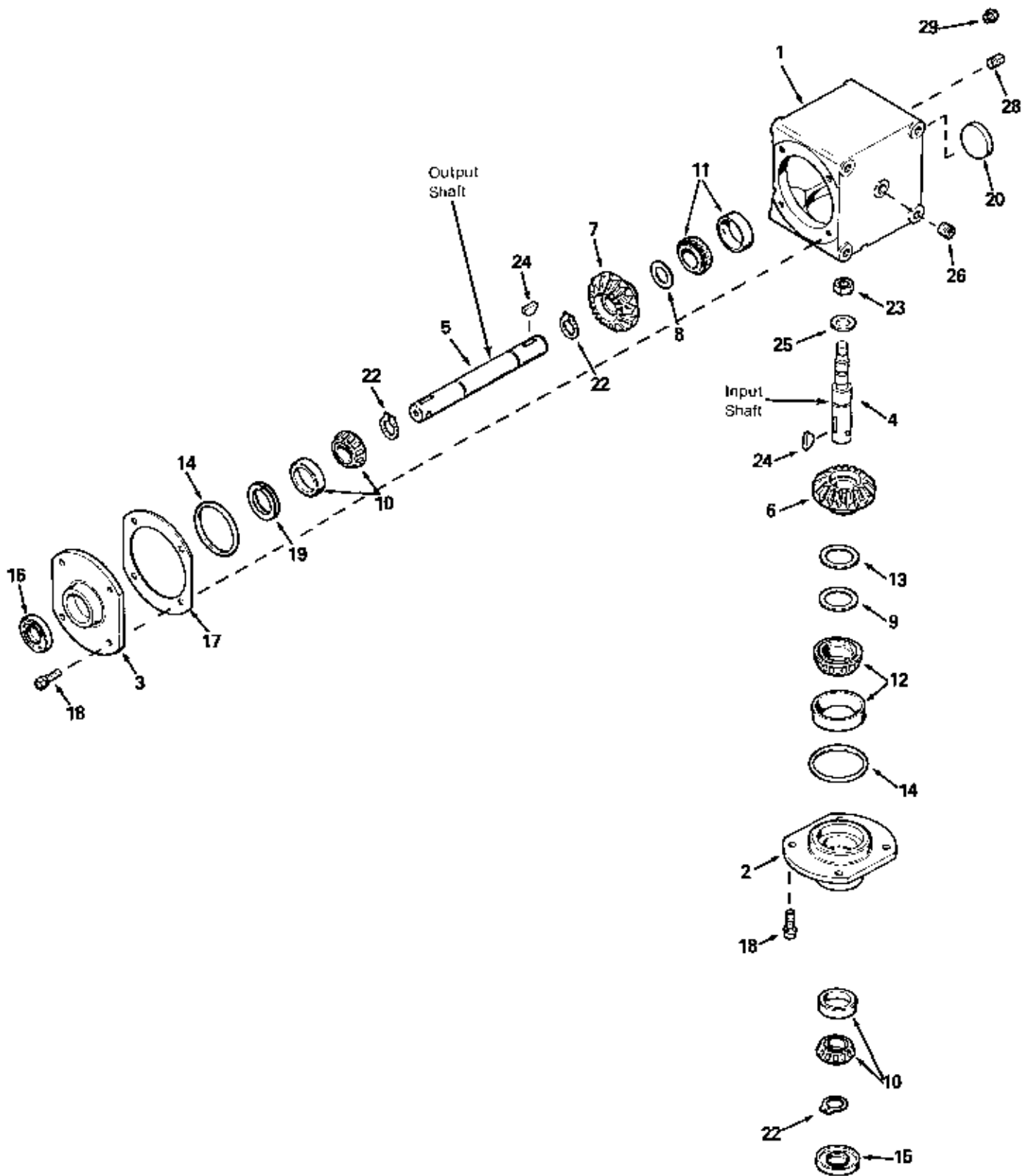

## Peerless Gear Box

Ref. No.	Part No.	Qty.	Description
1	770076	1	HOUSING, Right Angle Drive
2	786125	1	CAP, Retainer
3	786105	1	CAP, Retainer
4	776268	1	SHAFT, Input
5	776222	1	SHAFT, Output
6	778233	1	GEAR, Bevel (14 teeth)
7	778232	1	GEAR, Bevel (28 teeth)
8	780131	1	SHIM (1-1/2" O.D. x 1-1/64" I.D. x .002 thick) (Use as required)
9	780147	1	SHIM (1-3/4" O.D. x 1.265" I.D. x .002 thick) (Use as required)
10	780132	1	BEARING & CUP ASSY. (This assembly may have a shim washer included. The shim washer is not required at this location.)
11	780132	1	BEARING & CUP ASSY. (This is a factory sized assembly and may or may not include Ref. No. 8 Shim Washer. If Ref. No. 8 Shim Washer is supplied, it must be used in this location. All old shim washers must be discarded.)
12	780148	1	BEARING & CUP ASSY. (This is a factory sized assembly and may or may not include Ref. No. 9 Shim Washer. If Ref. No. 9 Shim Washer is included, it must be used in this location. All old shim washers must be discarded.)
13	780101	1	RACE, Thrust
14	788063	2	"O" Ring
15	788064	1	SEAL, Oil
16	788065	1	SEAL, Oil
17	780136	1	SHIM, Cap Retainer
18	792037	8	SCREW, Hex Hd. Sems, 5/16-18 x 1
19	780137	1	RING, Load
20	792111	1	PLUG
22	792113	3	RING, Retaining
23	792126	1	JAM NUT, 1/2-20, Hex
24	792114	1	KEY, Woodruff
25	792127	1	WASHER, Flat
26	792116	2	PLUG, Pipe, 1/4-18
28	792039	1	PLUG, Pipe, 1/8"
29	792118	1	VALVE, Relief

**NOTE:** See an authorized Tecumseh dealer for parts and service. Peerless parts are not available through Simplicity.

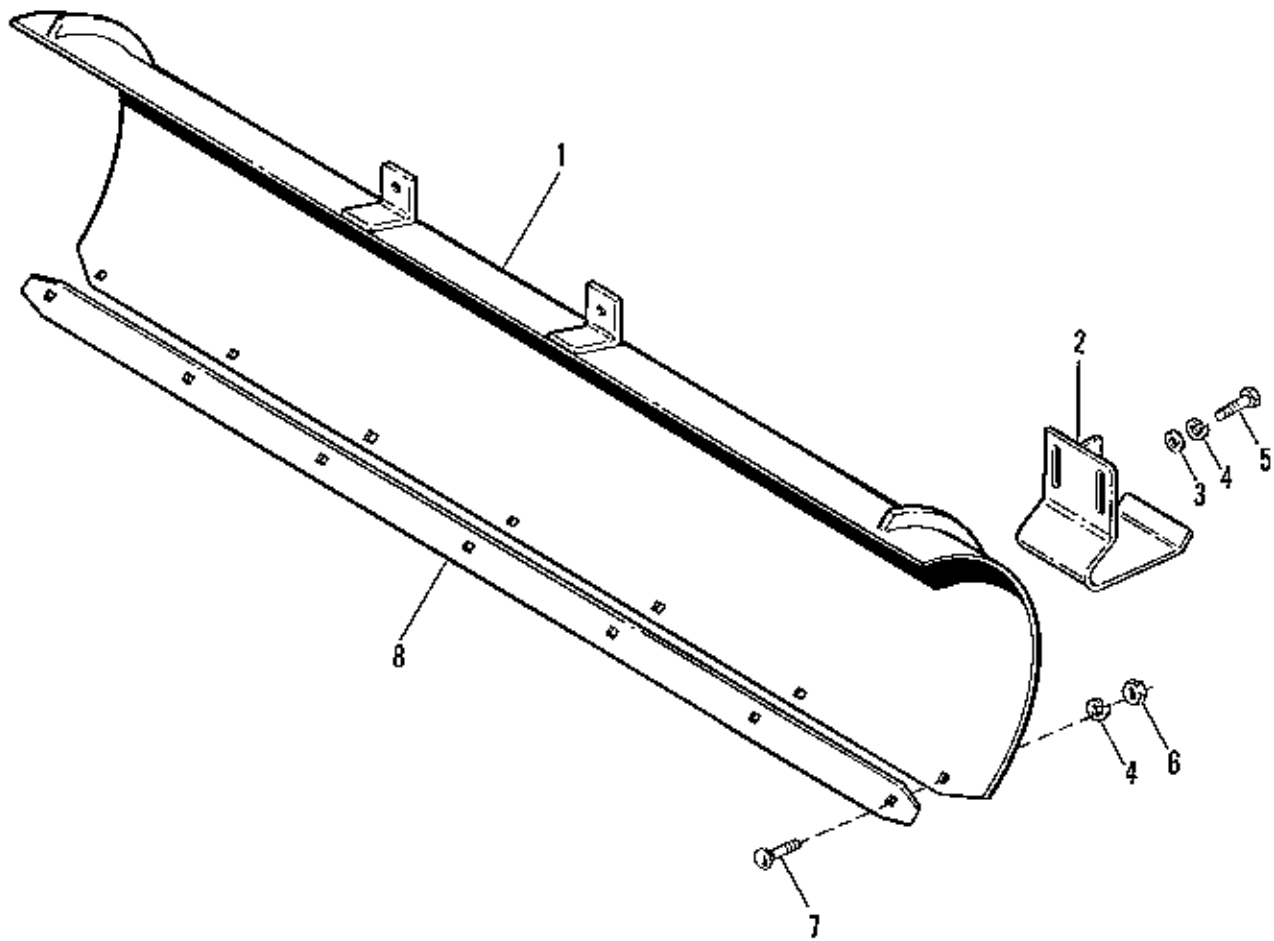

NOTE: Use standard hardware torque spec. chart unless otherwise noted.

46" Dozer Blade (Blade Group)

---

Ref. No.	Part No.	Qty.	Description
1	107096	1	BLADE ASSY.
2	107106	2	SHOE ASSY.
3	1917378	4	WASHER, 3/8 Std.
4	1916965	11	LOCKWASHER, 3/8 Std.
5	1921965	4	CAPSCREW, Hex Hd., 3/8-16 x 3/4
6	1916950	7	NUT, Hex, 3/8-16
7	1931350	7	BOLT, Carriage, 3/8-16 x 1
8	107105	1	PLATE, Wear

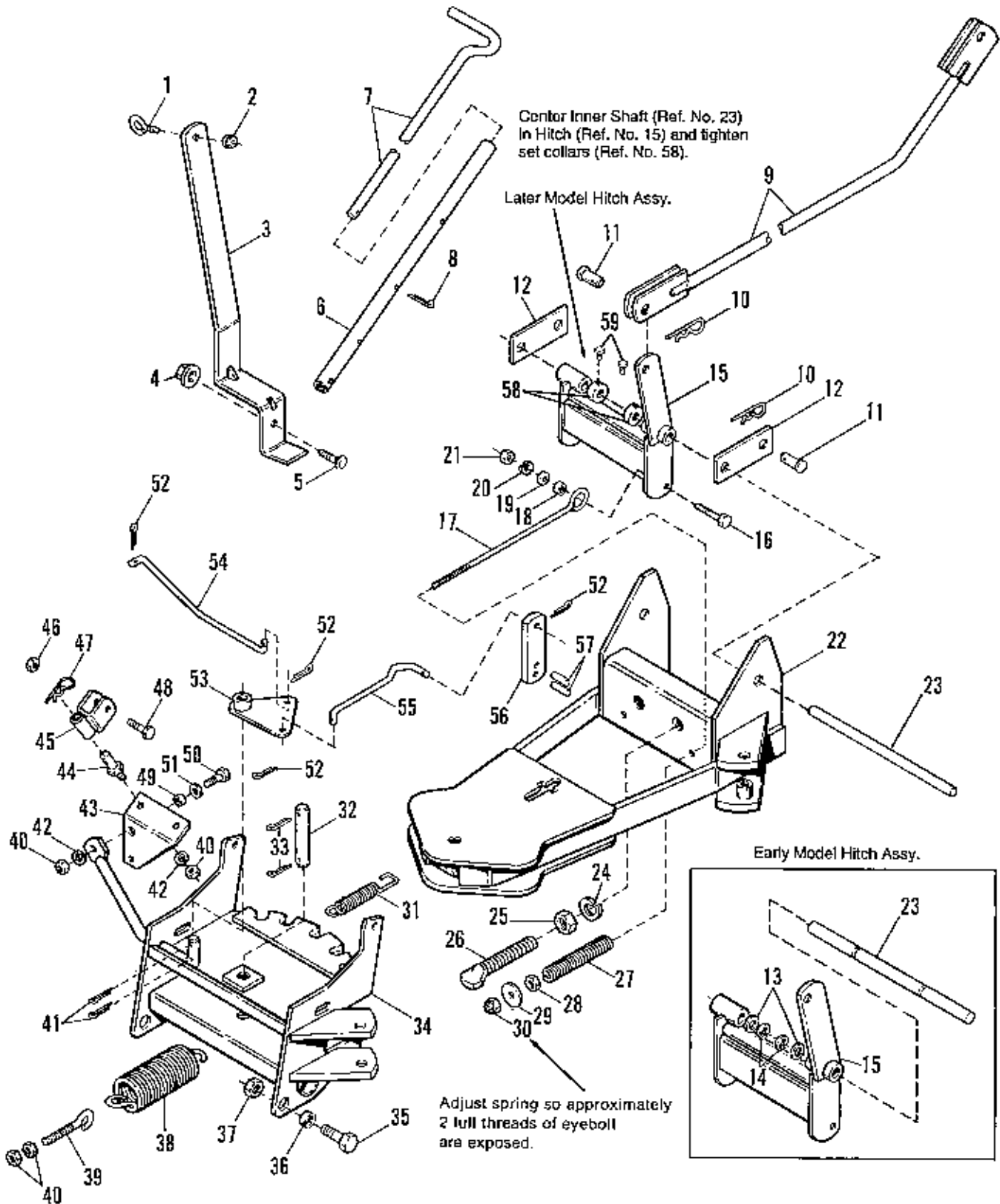

NOTE: Use standard hardware  
torque spec. chart unless  
otherwise noted.

## 46" Dozer Blade (Hitch Group)

Ref. No.	Part No.	Qty.	Description
1	172162	1	EYEBOLT
2	1923358	1	NUT, Hex Lock, 1/4-20
3	1676912	1	SUPPORT, Control Rod
4	1928352	1	NUT, Hex, Flange Whizlock, 3/8-16
5	1928727	1	BOLT, Carriage, 3/8-16 x 1-1/4
6	1679063	1	SLEEVE, Connector
7	1676880	1	HANDLE, Pivot
8	1918452	1	PIN, Cotter, 1/8 x 1, Pil.
9	1675390	1	LIFT ROD ASSY.
10	1960033	4	CLIP, Spring
11	1960038	4	PIN, Clevis
12	1675525	2	LINK
13	* 1919387	2	WASHER, Plain, 41/64 x 1-1/4 x 1/16
14	* 927793	2	E-RING, Retaining, 5/8
15	1675502	1	HITCH ASSY.
16	1922664	2	CAPSCREW, Hex Hd., 5/8-11 x 2
17	1679055	2	EYEBOLT
18	175647	2	SPACER
19	933757	2	WASHER, Plain, 41/64 x 1-3/4 x 1/8
20	1917373	2	LOCKWASHER, 5/8 Std.
21	1923353	2	NUT, Hex, 5/8-11
22	1700664	1	HITCH ASSY, Dozer
23	* 1676350	1	SHAFT, Inner, Hitch
	** 1708999	1	SHAFT, Inner, Hitch
24	1919332	2	LOCKWASHER, 3/4 Std.
25	1913160	2	NUT, Hex, 3/4-10
26	1676959	2	STUD, 3/4-10 UNC - 2A
27	1675524	2	SPRING, Compression
28	1917421	2	NUT, Jam, Hex, 3/8-16
29	1960071	2	WASHER, 13/32 x 1-1/4 x 1/4
30	1916950	2	NUT, Hex, 3/8-16

See pages 118 - 119 for Ref. Nos. 31 -59.

\* Used on Early Models (see art page).

\*\* Used on Later Models (see art page.).

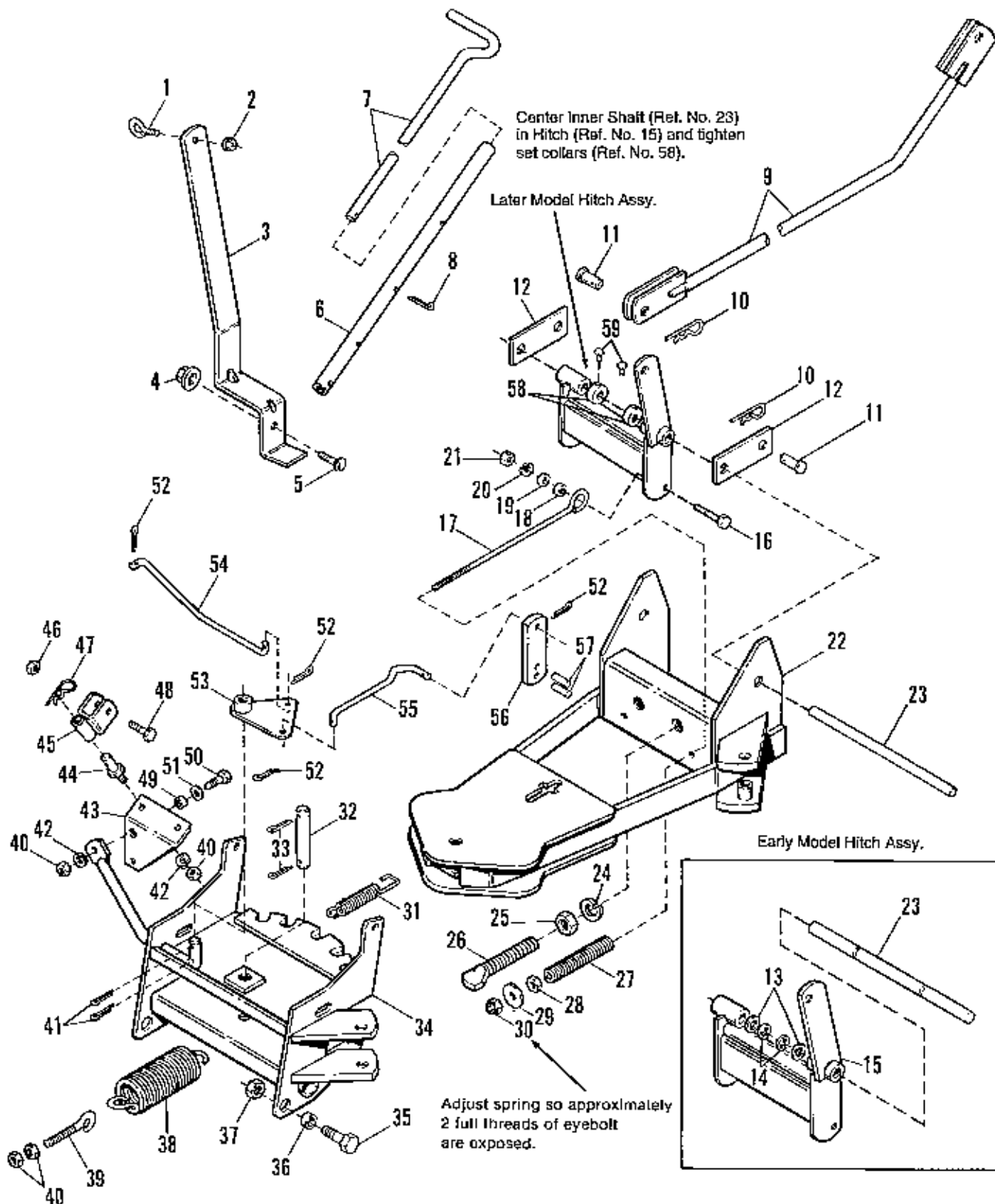

NOTE: Use standard hardware  
torque spec. chart unless  
otherwise noted.



## 46" Dozer Blade (Hitch Group)

Ref. No.	Part No.	Qty.	Description
31	107135	1	SPRING
32	174066	1	PIN, Pivot
33	1919314	2	PIN, Cotter, 3/16 x 1-1/4
34	1700665	1	FRAME ASSY., Pivot
35	1920328	2	CAPSCREW, Hex Hd., 1/2-13 x 1-1/2
36	105051	2	SPACER
37	1922134	2	NUT, Hex, Lock, 1/2-13
38	101126	2	SPRING, Tension
39	107121	2	EYEBOLT
40	1917372	6	NUT, Hex, 5/16-18
41	1918452	2	PIN, Cotter, 1/4 x 1
42	1917356	2	LOCKWASHER, 5/16 Std.
43	1676988	1	ARM, Pivot
44	107120	1	STUD
45	106131	1	FORK ASSY.
46	1929362	1	NUT, Hex, Lock, 5/16-18
47	1960074	1	CLIP, Spring
48	1921221	1	CAPSCREW, Hex Hd., 5/16-18 x 1-1/2
49	1666697	1	SPACER
50	1921333	1	CAPSCREW, Hex Hd., 5/16-18 x 1
51	1917642	1	WASHER, 5/16 Std.
52	1918447	4	PIN, Cotter, 3/32 x 3/4
53	107116	1	PLATE ASSY., Pivot
54	107118	1	ROD, Pivot
55	107136	1	ROD, Latch
56	174073	1	LATCH
57	921468	2	PIN, Spring, 7/32 x 1
58	** 8031007	2	SET COLLAR
59	** 1928721	2	SET SCREW, Sq. Hd. cup point, 5/16-18 x 1/2

See pages 116 - 117 for Ref. Nos. 1 - 30

\* Used on Early Models (see art page).

\*\* Used on Later Models (see art page.).

Early Model Hitch Assy.

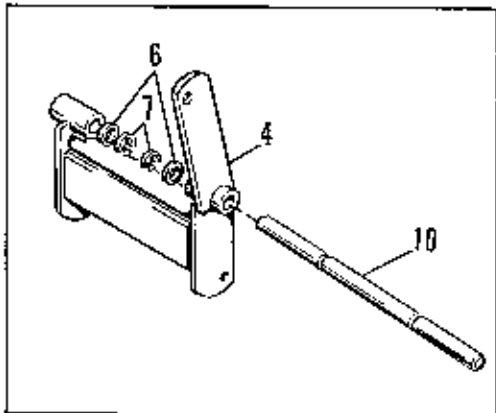

Center Inner Shaft (Ref. No. 10)  
in Hitch (Ref. No. 4) and tighten  
set collars (Ref. No. 32).

Later Model Hitch Assy.

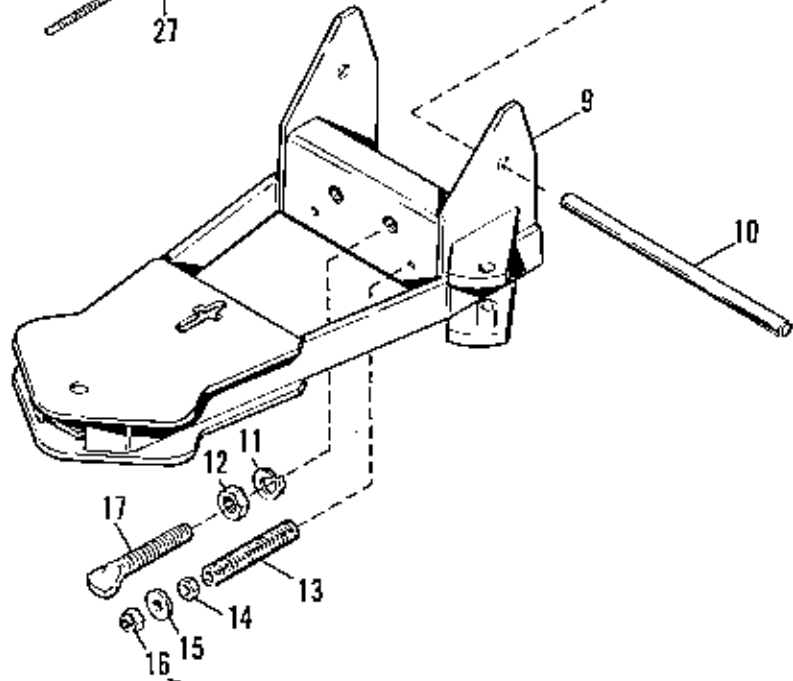
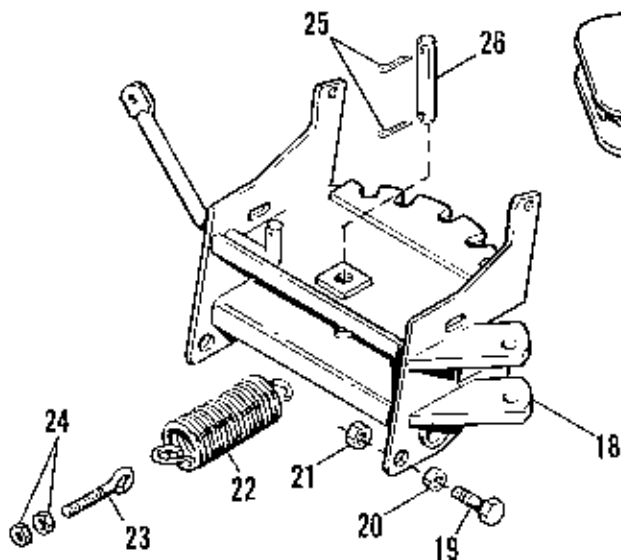
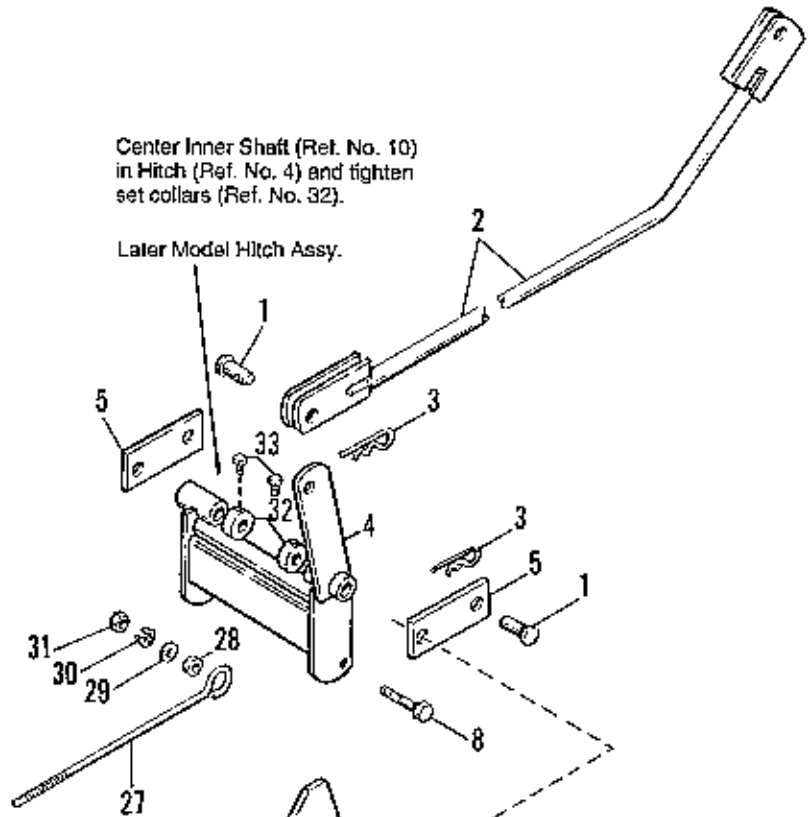

Adjust spring so approximately  
2 full threads of eyebolt  
are exposed.

NOTE: Use standard hardware  
torque spec. chart unless  
otherwise noted.

## 46" Dozer Blade (Hitch Group)

Ref. No.	Part No.	Qty.	Description
1	1960038	4	PIN, Clevis
2	1675390	1	ROD ASSY., Lift
3	1960033	4	CLIP, Spring
4	1675502	1	HITCH ASSY.
5	1675525	2	LINK
6	* 1919387	2	WASHER, Plain, 41/64 x 1-1/4 x 1/16
7	* 927793	2	E-RING, Retaining
8	1922664	2	CAPSCREW, Hex Hd., 5/8-11 x 2" Lg.
9	1700664	1	HITCH ASSY, Dozer
10	* 1676350	1	SHAFT, Inner
	** 1708999	1	SHAFT, Inner
11	1919332	2	LOCKWASHER, 3/4"
12	1913160	2	NUT, Hex, 3/4-10
13	1675524	2	SPRING, Compression
14	1917421	2	NUT, Hex Jam, 3/8-16
15	1960071	2	WASHER, 13/32 x 1-1/4 x 1/4
16	1916950	2	NUT, Hex, 3/8-16
17	1676959	2	STUD, 3/4-10
18	1700665	1	FRAME ASSY, Pivot
19	1920328	2	CAPSCREW, Hex Hd., 1/2-13 x 1 Lg.
20	105051	2	SPACER
21	1922134	2	NUT, Hex, Lock, 1/2-13
22	101126	2	SPRING, Tension
23	107121	2	EYEBOLT
24	1917372	4	NUT, Hex, 5/16-18
25	1919314	2	PIN, Cotter, 3/16 x 1-1/4 Lg.
26	174066	1	PIN, Pivot
27	1679055	2	EYEBOLT
28	175647	2	SPACER
29	933757	2	WASHER, Plain, 41/64 x 1-3/4 x 1/8
30	1917373	2	LOCKWASHER, 5/8
31	1923353	2	NUT, Hex, 5/8-11
32	** 8031007	2	SET COLLAR
33	** 1928721	2	SETSCREW, Square Hd. Cup Point, 5/16-18 x 1/2

\* Used on Early Models (see art page).

\*\* Used on Later Models (see art page.).

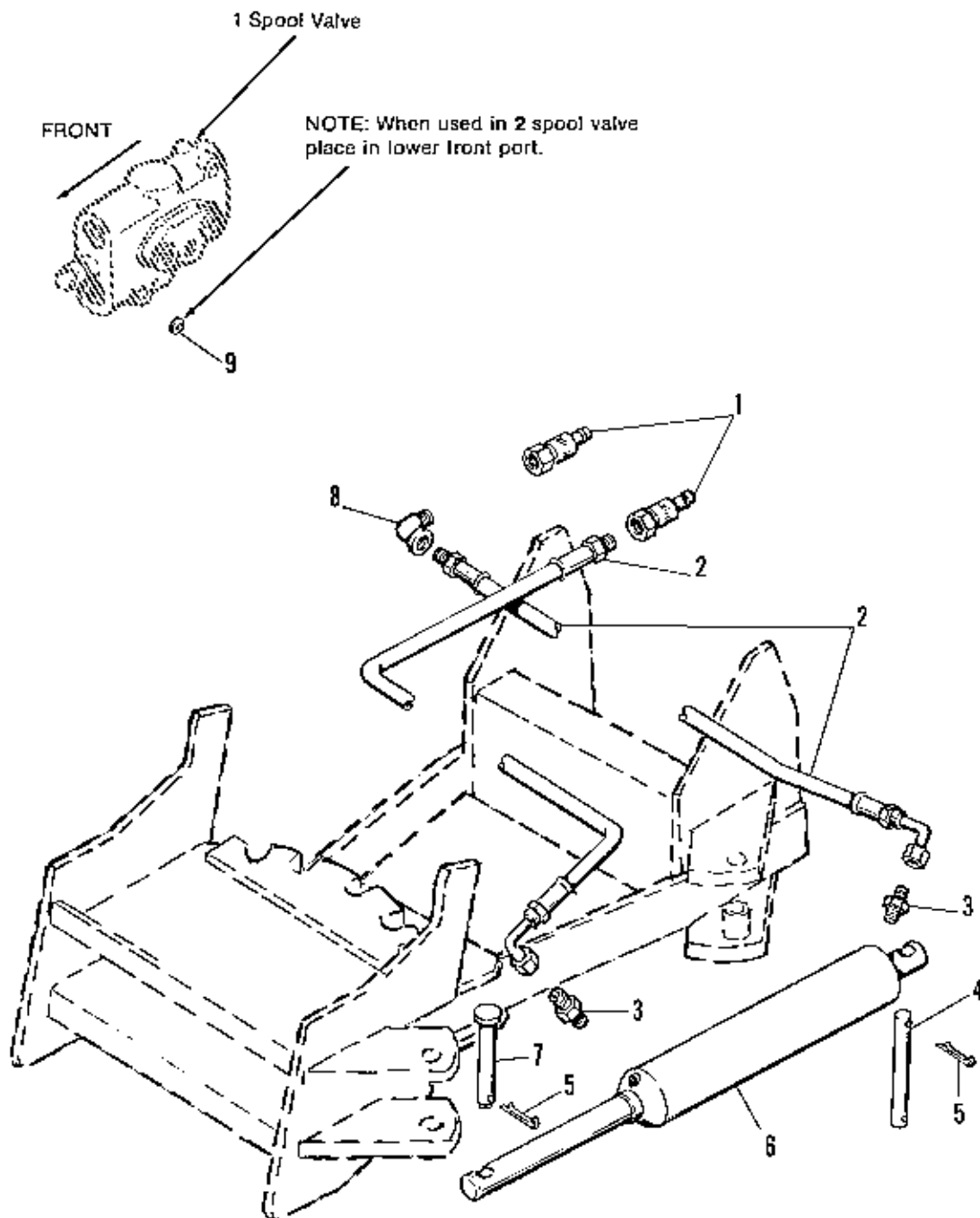

NOTE: Use standard hardware  
torque spec. chart unless  
otherwise noted.

Hydraulic Group

---

Ref. No.	Part No.	Qty.	Description
1	173359	2	NOSE PIECE ASSY.
2	1700707	2	HOSE ASSY., Hyd.
3	919766	2	FITTING, Male
4	1700394	1	PIN, Cylinder
5	1918452	3	PIN, Cotter, 1/8 x 1 Lg.
6	1677214	1	CYLINDER ASSY.
7	1960277	1	PIN, Yoke
8	960309	1	ELBOW, Street, 90
9	1685300	1	WASHER, Restrictor

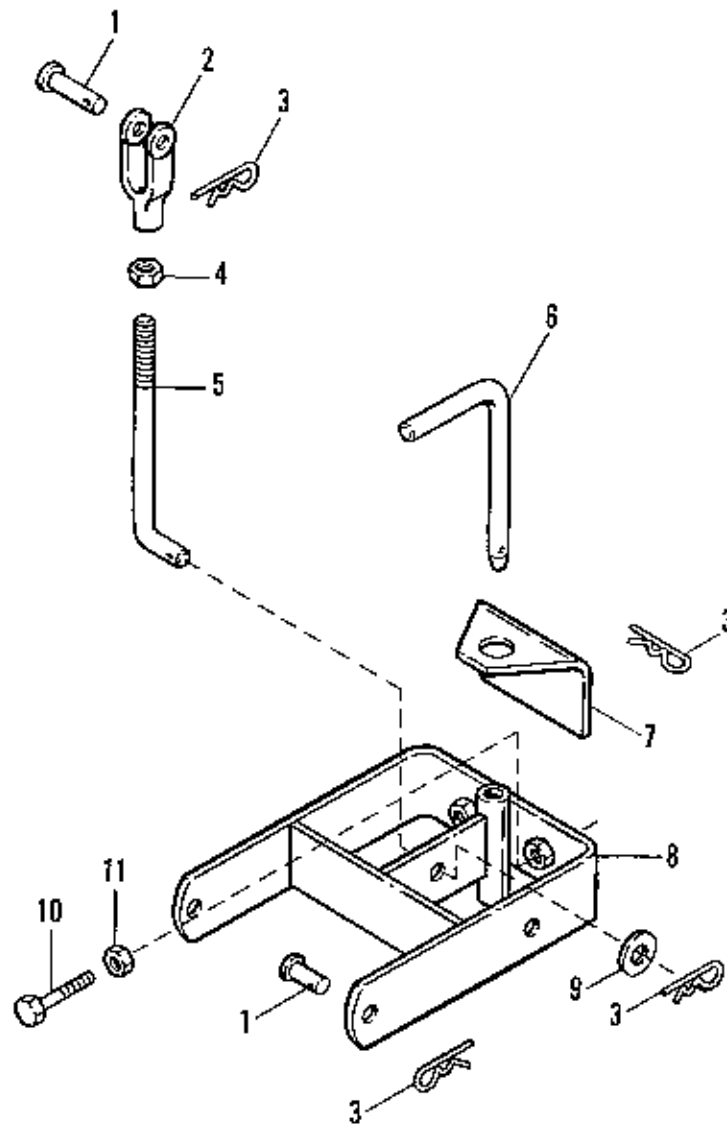

NOTE: Use standard hardware torque spec. chart unless otherwise noted.

One Point Hitch Group

---

Ref. No.	Part No.	Qty.	Description
1	1960116	3	PIN, Yoke
2	154304	1	YOKE, End Adj.
3	1960033	5	CLIP, Spring
4	1919262	1	NUT, Hex, Jam, 1/2-20
5	1604349	1	ROD, Lift
6	1603321	1	PIN, Hitch
7	1603816	1	PLATE, Stabilizer
8	1675373	1	CLEVIS ASSY.
9	1924361	1	WASHER, 17/32 x 1-1/4 x 1/16
10	1927430	2	CAPSCREW, Hex Hd., 5/8-11 x 2-1/4
11	1915726	2	NUT, Hex, 5/8-11

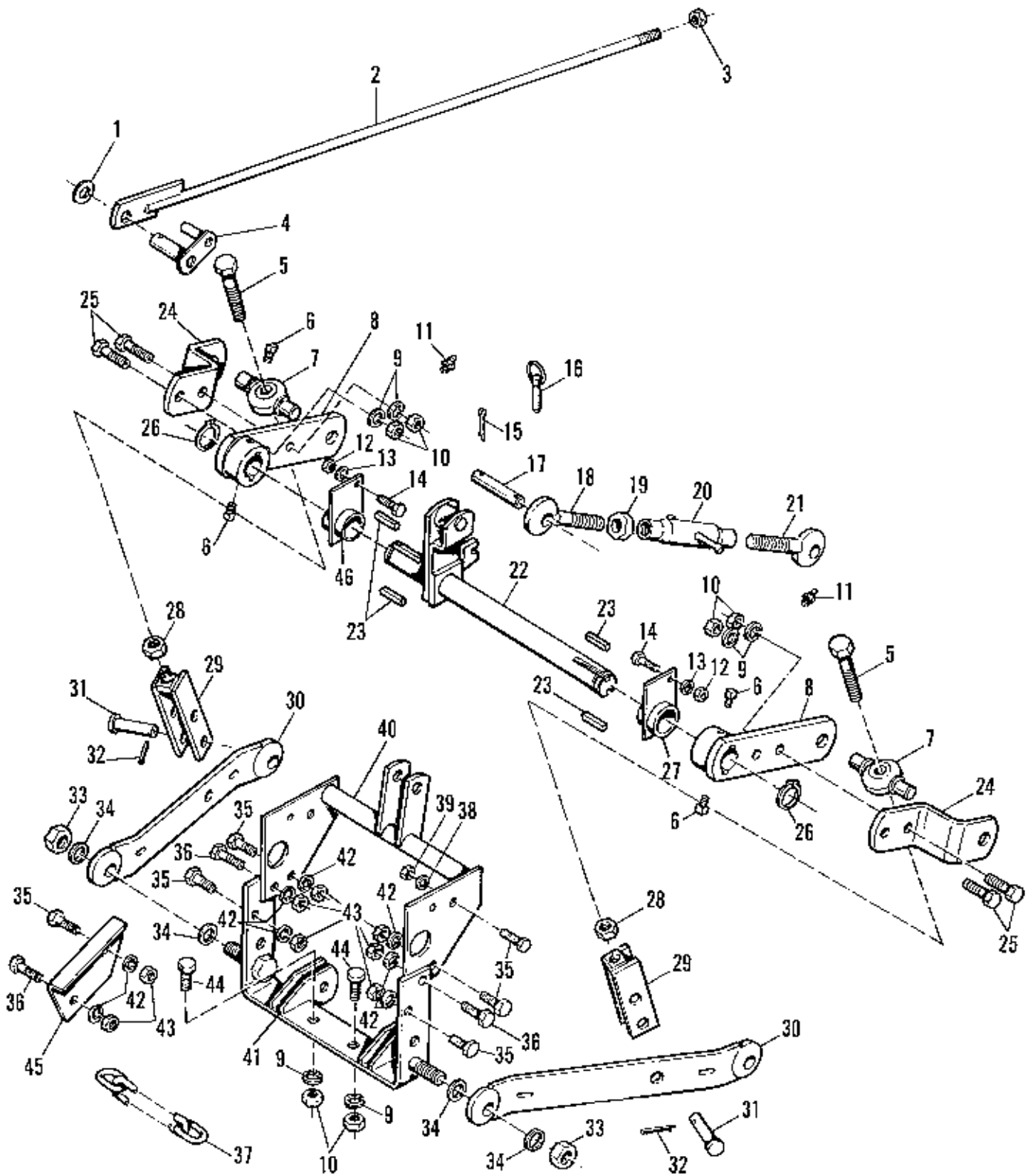

NOTE: Use standard hardware torque spec. chart unless otherwise noted.



## Three Point Hitch

Ref. No.	Part No.	Qty.	Description
1	1919387	1	WASHER, Plain, 41/64 x 1-1/4 x 1/16
2	1703840	1	ROD ASSY., Lift
3	1922134	1	NUT, Hex, Lock, 1/2-13
4	1674529	1	PIN ASSY., Cylinder
5	1960329	2	CAPSCREW, Hex Hd., 5/8-11 x 4
6	1930536	4	SETSCREW, Sq. Hd., 3/8-16 x 3/4
7	1679467	2	BALL SOCKET ASSY.
8	1679477	2	LIFT LINK ASSY.
9	1916966	4	LOCKWASHER, 1/2
10	1916951	4	NUT, Hex, 1/2-13
11	172761	2	FITTING, Lub.
12	1917372	2	NUT, Hex, 5/16-18
13	1917356	2	LOCKWASHER, 5/16
14	1921977	2	CAPSCREW, Hex Hd., 5/16-18 x 1-1/4
15	918461	2	PIN, Cotter, 1/4 x 1-1/2
16	1679697	8	PIN & RING ASSY., 1/4" Dia.
17	171695	2	PIN, Pivot
18	1700419	1	STUD ASSY., Adjust. R.H.
19	1960297	1	NUT, Hex, Jam, 3/4-10
20	1700479	1	TUBE ASSY., Upper Link
21	1700418	1	STUD ASSY., Adjust. L.H.
22	1701289	1	LIFT SHAFT ASSY.
23	960306	4	KEY, Sq. 5/16 x 1-1/2
24	1679466	2	BRACKET, Lift Link
25	1921525	4	CAPSCREW, Hex Hd., 1/2-13 x 1-3/4
26	932726	2	RING, Retaining, Ext., 1-1/4 Dia.
27	1701305	1	BEARING ASSY., L.H.
28	1930631	2	NUT, Hex, Lock, Jam, 5/8-11
29	1701300	2	CLEVIS ASSY.
30	1679470	2	LINK ASSY., Lower
31	1960277	2	PIN, Clevis, 5/8 x 2-1/4
32	1918452	2	PIN, Cotter, 1/8 x 1
33	1926662	2	NUT, Hex, Centerlock, 3/4-10
34	1960114	4	WASHER, 1 x 3/4 x 5/64
35	1920677	6	CAPSCREW, Hex Hd., 7/16-14 x 1-1/4
36	1921212	3	CAPSCREW, Hex Hd., 7/16-14 x 1-1/2
37	1700312	2	CHAIN, Sway, 22-5/8
38	1917378	1	WASHER, Plain, 7/16
39	1935041	1	NUT, Hex, Whizlock, 7/16-14
40	1701297	1	LINK ASSY., Upper
41	1679731	1	BRACKET ASSY., Hitch
42	1918199	7	LOCKWASHER, 7/16
43	1918213	7	NUT, Hex Hd., 7/16-14
44	1921176	2	CAPSCREW, Hex Hd., 1/2-13 x 2
45	1701296	1	BRACKET, Upper Stop
46	1701304	1	BEARING ASSY., R.H.

NOTE 1: Items in box are not used on the 20 HP SunStar, Mfg. No. 1691710. (The rest of the parts shown here are applicable to this particular tractor.)

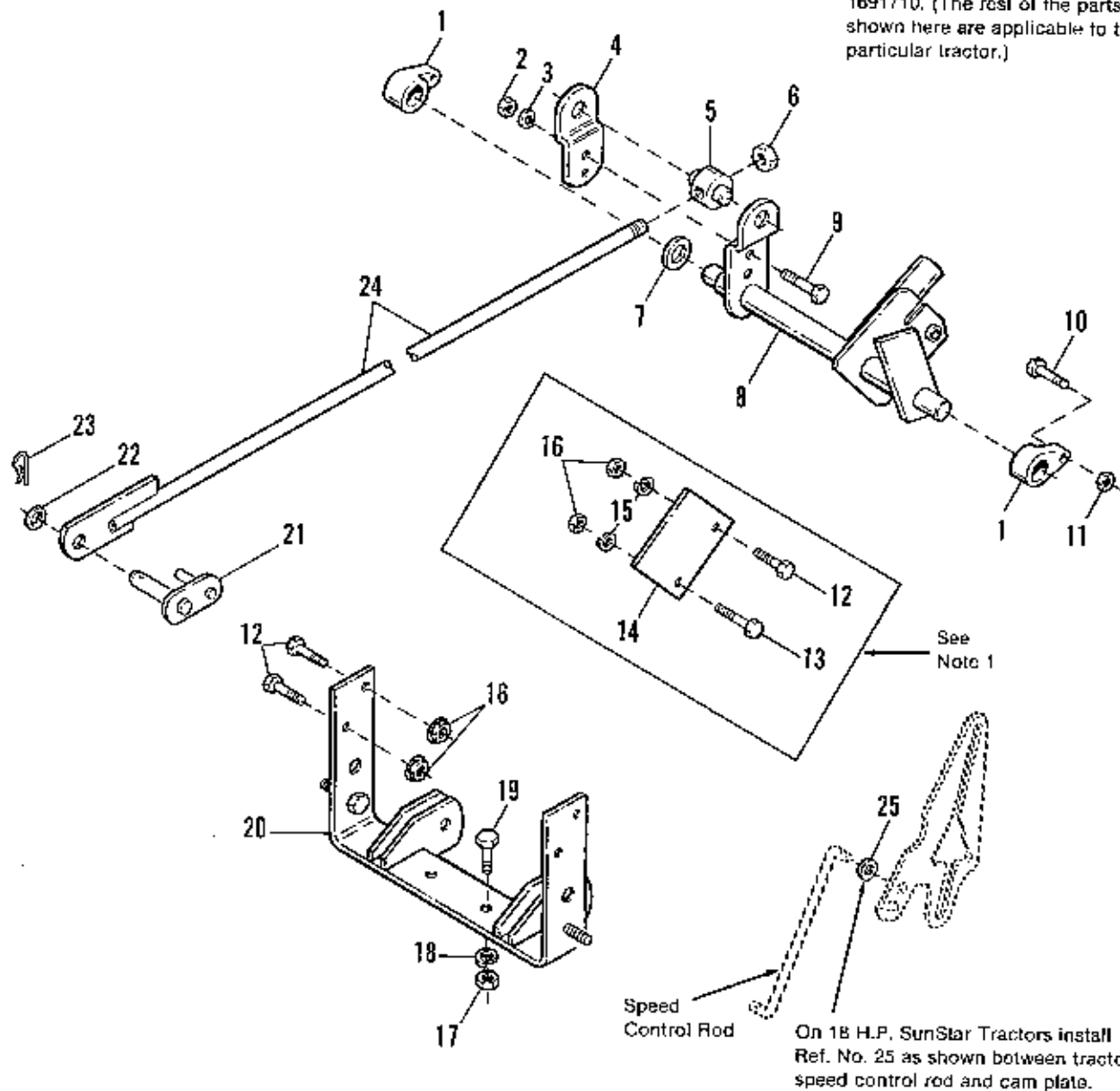

NOTE: Use standard hardware torque spec. chart unless otherwise noted.

## Rear Lift Group

Ref. No.	Part No.	Qty.	Description
1	1670728	2	BEARING
2	1916950	2	NUT, Hex, 3/8-16
3	1916965	2	LOCKWASHER, 3/8
4	1676441	1	ARM, Lift (Bolt on)
5	1674947	1	TRUNNION
6	1922134	1	NUT, Hex, Lock, 1/2-13
7	1960230	1	WASHER, Plain, 1 x 1-3/8 x 1/16
8	1678995	1	SHAFT ASSY., Lift
9	1921210	2	CAPSCREW, Hex Hd., 3/8-16 x 1
10	1921977	2	CAPSCREW, Hex Hd., 5/16-18 x 1-1/4
11	1923362	2	NUT, Hex, Centerlock, 5/16-18
*12	1923471	5	CAPSCREW, Hex Hd., 7/16-14 x 1-1/4 (Qty. 4 on 1691765)
*13	1923451	1	CAPSCREW, Hex Hd., 7/16-14 x 1-1/2
*14	1677006	1	PLATE, End
*15	1918199	2	LOCKWASHER, 7/16
*16	1935041	6	NUT, Hex, Flange Whizlock, 7/16-14
17	1916951	2	NUT, Hex, 1/2-13
18	1916966	2	LOCKWASHER, 1/2
19	1920328	2	CAPSCREW, Hex Hd., 1/2-13 x 1-1/2
20	1679731	1	BRACKET ASSY., Hitch
21	1674529	1	CYLINDER PIN ASSY.
22	1919387	1	WASHER, Plain, 41/64 x 1-1/4 x 1/16
23	1960033	1	CLIP, Hair Pin, 1/8 x 2-9/16
24	1703840	1	ROD ASSY., Lift
25	157424	1	WASHER, Special (Use on 18 HP Only)

\*NOTE: Items 12 (Qty. 1), 13, 14, 15 & 16 (Qty. 2) are not used on SunStar tractor 1691710.

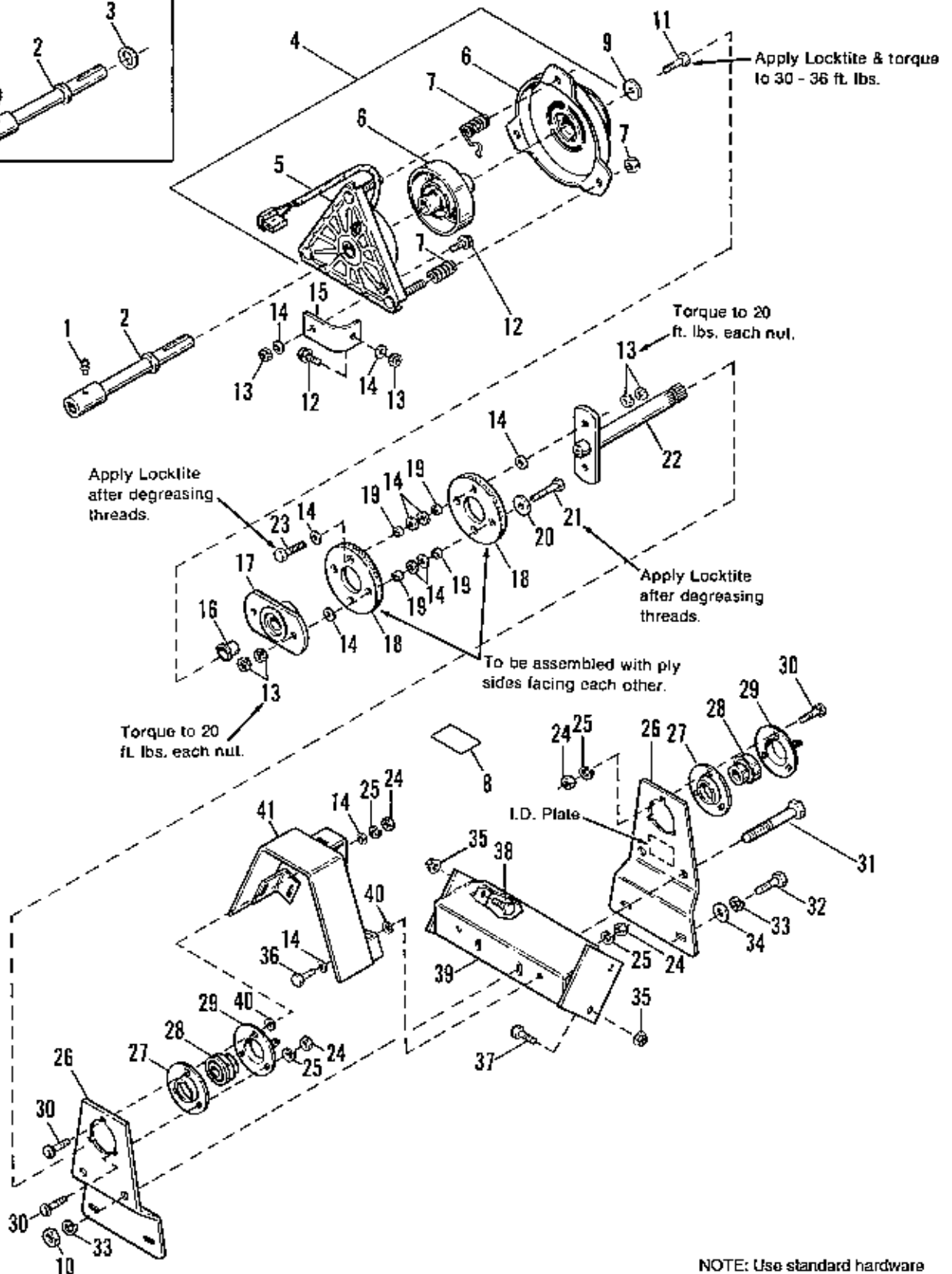
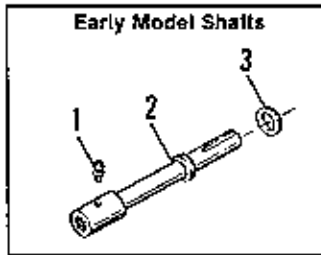

Ref. No.	Part No.	Qty.	Description
1	913958	1	FITTING, Grease
2	1679710	1	SHAFT ASSY.
3	1960070	1	WASHER, Plain, 1-1/32 x 1-3/4 x 3/16 (Early models only.)
4	1676794	1	ELECTRIC CLUTCH (Incl. Ref. Nos. 5, 6, 7 & 8)
5	1679101	1	FIELD ASSY.
6	1685489	1	ROTOR, ARMATURE & BRAKE ASSY.
7	1679104	1	ACCESSORY KIT (3 Spring & 3 Nuts)
8	1679155	1	DECAL, Rear P.T.O.
9	1676997	1	WASHER, 13/32 x 1-1/2 x 1/4
10	1916951	2	NUT, Hex, 1/2-13
11	1921210	1	CAPSCREW, Hex Hd., 3/8-16 x 1, Gr. 5
12	1930591	2	CAPSCREW, Whizlock, Flange, 5/16-18 x 3/4, Gr. 5
13	1923362	10	NUT, Hex, Centerlock, 5/16-18
14	1917642	17	WASHER, Plain, 5/16
15	1685494	1	TORQUE STRAP KIT
16	1676998	1	BUSHING
17	1702011	1	HUB ASSY.
18	1676829	2	FLEX COUPLING
19	156150	8	SPACER
20	1933468	2	WASHER, Plain, 11/32 x 1-1/4 x 1/8
21	1921978	2	CAPSCREW, Hex Hd., 5/16-18 x 2
22	1677002	1	SHAFT ASSY., P.T.O.
23	1921221	2	CAPSCREW, Hex Hd., 5/16-18 x 1-1/2
24	1917372	8	NUT, Hex, 5/6-18
25	1917356	8	LOCKWASHER, Spring, 5/16-18
26	1677009	2	SUPPORT, Rear P.T.O.
27	172278	2	FLANGE, Bearing
28	173934	2	BEARING, Cartridge w/Lock Collar
29	172279	2	FLANGE, Bearing
30	1931335	6	BOLT, Carriage, 5/16-18 x 1
31	1923161	2	CAPSCREW, Hex Hd., 1/2-13 x 4-1/2, Gr. 5
32	1920328	2	CAPSCREW, Hex Hd., 1/2-13 x 1-1/2
33	1916966	2	LOCKWASHER, Spring, 1/2
34	1918431	2	WASHER, Plain, 9/16 x 1-3/8
35	1935041	4	NUT, Hex, Flange Whiz, 7/16-14
36	1923325	2	CAPSCREW, Hex Hd., 5/16-18 x 7/8, Gr. 5
37	1923451	2	CAPSCREW, 7/16-14 x 1-1/2, Gr. 8
38	1923471	2	CAPSCREW, Hex Hd., 7/16-14 x 1-1/4, Gr. 8
39	1677004	1	BRACKET ASSY.
40	933988	3	NUT, Push Pal, 5/16
41	1677207	1	GUARD ASSY.

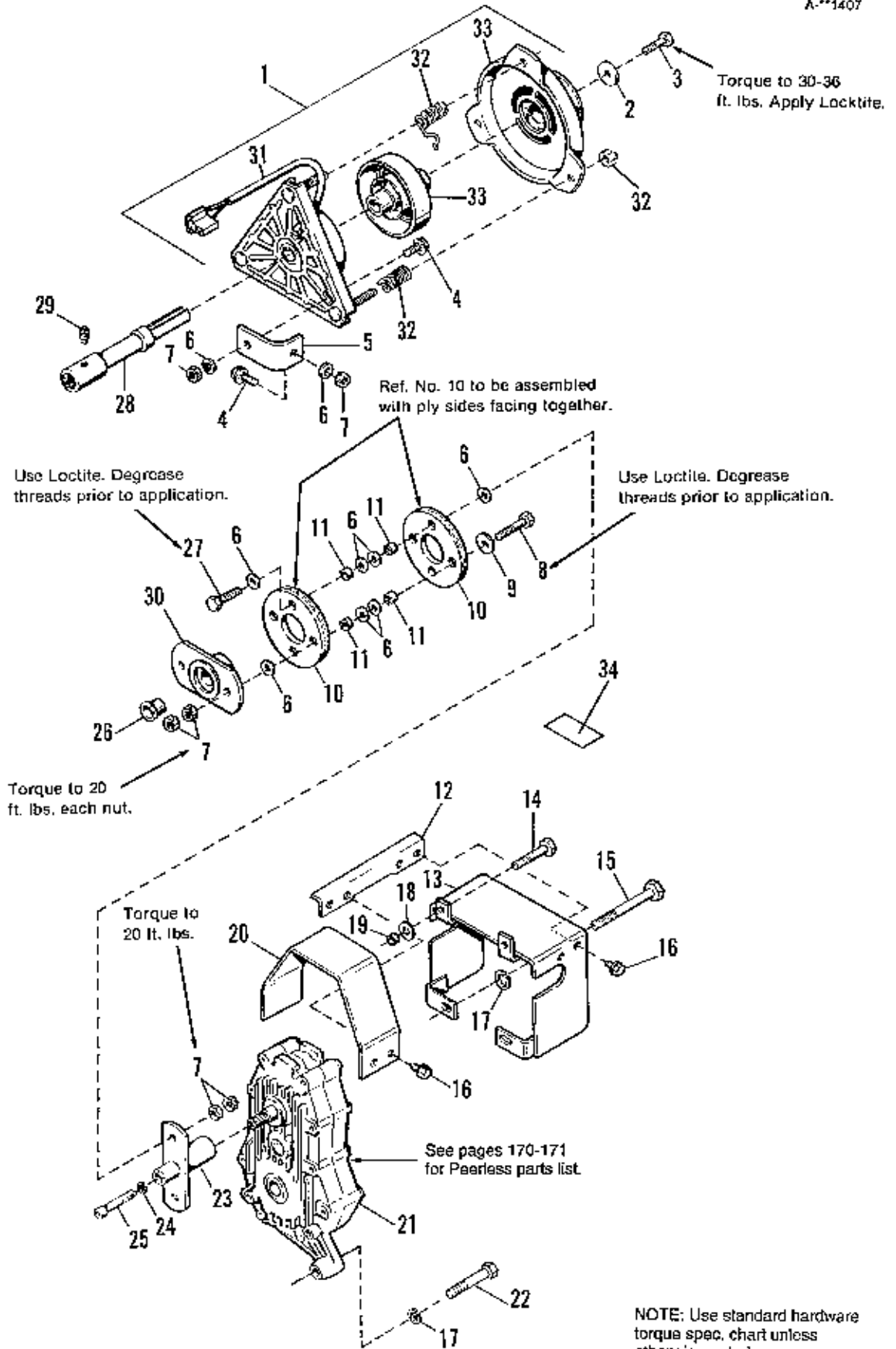

Ref. No.	Part No.	Qty.	Description
1	1676794	1	CLUTCH, Electric (Incl. Ref. Nos. 31-34)
2	1676997	1	WASHER
3	1921210	1	CAPSCREW, Hex Hd., 3/8-16 x 1, Gr. 5
4	1930591	2	CAPSCREW, Whizlock, 5/16-18 x 3/4, Gr. 5
5	1685494	1	TORQUE STRAP KIT
6	1917642	16	WASHER, Plain, 5/16
7	1923362	10	NUT, Hex, Centerlock, 5/16-18
8	1921978	2	CAPSCREW, Hex Hd., 5/16-18 x 2
9	1933468	2	WASHER, Plain, 5/16 x 1-1/2 x 9/64
10	1676829	2	COUPLING, Flex
11	156150	8	SPACER
12	1679997	2	SUPPORT, P.T.O. Guard
13	1700010	1	GUARD ASSY., P.T.O.
14	1921978	2	CAPSCREW, Hex Hd., 5/16-18 x 2, Gr. 5
15	1926158	2	CAPSCREW, Hex Hd., 1/2-13 x 4, Gr. 8
16	1924856	8	CAPSCREW, Washer Hd., Taplute, 5/16-18 x 1/2
17	1916966	3	LOCKWASHER, 1/2
18	1917642	2	WASHER,, Plain, 5/16
19	1675481	2	SPACER
20	1679998	1	GUARD, Disc.
*21		1	GEAR BOX, 2000 RPM (Peerless)
22	1927469	1	CAPSCREW, Hex Hd., 1/2-13 x 2-1/4, Gr. 8
23	1709982	1	ADAPTER ASSY.
24	1917356	1	LOCKWASHER, 5/16
25	1960292	1	CAPSCREW, Hex Hd, 5/16-24 x 2-1/4
26	1676998	1	BUSHING
27	1921221	2	CAPSCREW, Hex Hd., 5/16-18 x 1-1/2, Gr. 5
28	1679710	1	SHAFT ASSY.
29	913958	1	FITTING, Grease w/Ball
30	1676999	1	HUB ASSY.
31	1679101	1	FIELD ASSY.
32	1679104	1	ACCESSORY KIT (3 Springs & 3 Nuts)
33	1685489	1	ROTOR, ARMATURE & BRAKE ASSY.
34	1679155	1	DECAL, Rear P.T.O.

For Peerless parts breakdown, see page 170. Order Gear Box and component parts from Peerless.

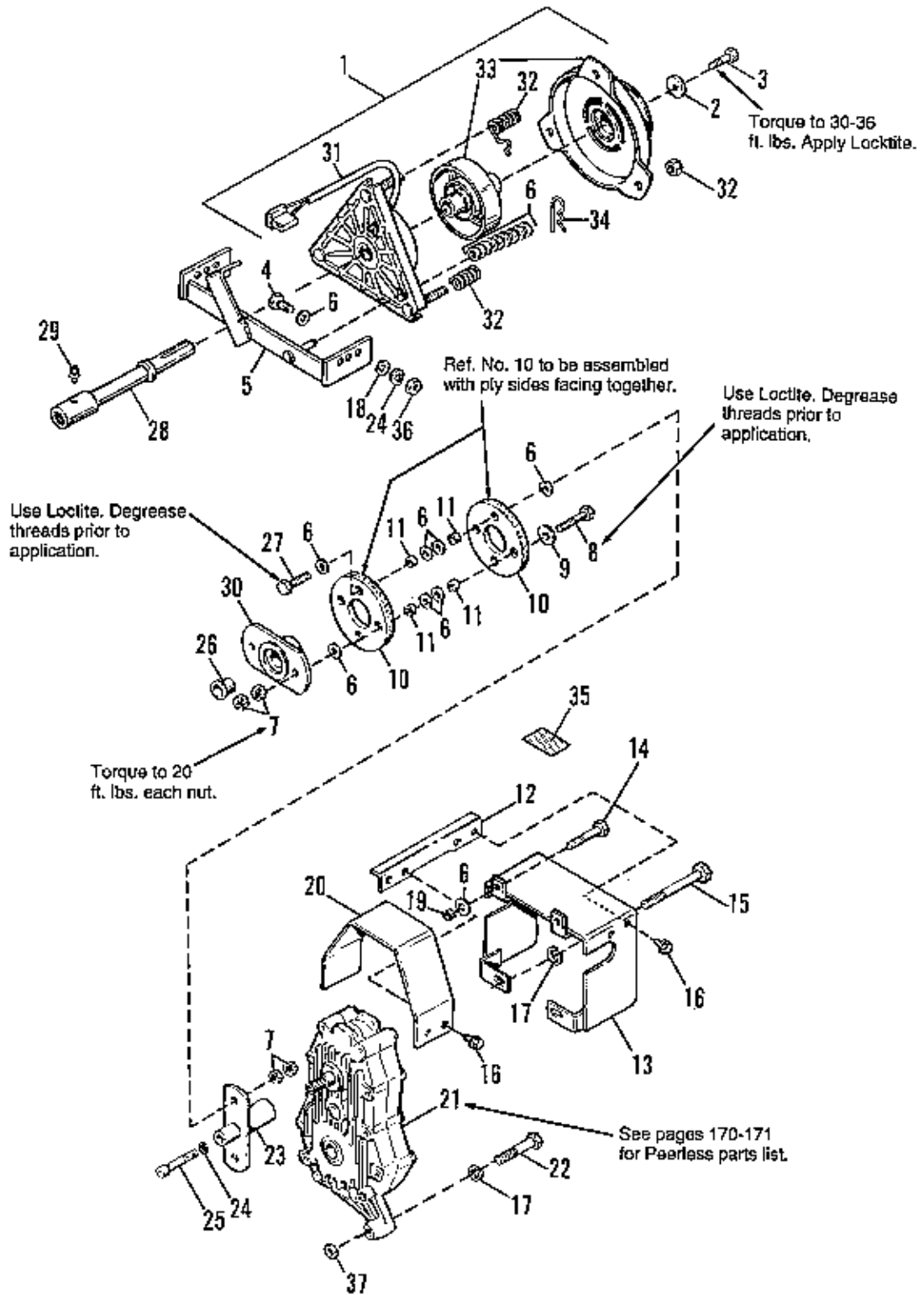

NOTE: Use standard hardware torque spec. chart unless otherwise noted.



Ref. No.	Part No.	Qty.	Description
1	1676794	1	CLUTCH, Electric (Incl. Ref. Nos. 31-34)
2	1708264	1	WASHER
3	1921210	1	CAPSCREW, Hex Hd., 3/8-16 x 1, Gr. 5
4	1921333	4	CAPSCREW, Whizlock, 5/16-18 x 1
5	1709197	1	PLATE ASSY., Rear P.T.O.
6	1919326	36	WASHER, Plain, 11/32 I.D. X 3/4 O.D. X 1/16
7	1923362	8	NUT, Hex, Centerlock, 5/16-18
8	1921978	2	CAPSCREW, Hex Hd., 5/16-18 x 2
9	1933468	2	WASHER, Plain, 5/16 x 1-1/2 x 9/64
10	1676829	2	COUPLING, Flex
11	156150	8	SPACER
12	1679997	2	SUPPORT, P.T.O. Guard
13	1700010	1	GUARD ASSY., P.T.O.
14	1921978	2	CAPSCREW, Hex Hd., 5/16-18 x 2, Gr. 5
15	1926158	2	CAPSCREW, Hex Hd., 1/2-13 x 4, Gr. 8
16	1924856	8	CAPSCREW, Washer Hd., Taptite, 5/16-18 x 1/2
17	1916966	3	LOCKWASHER, 1/2
18	1919381	4	WASHER, Plain, 11/32 x 1
19	1675481	2	SPACER
20	1679998	1	GUARD, Disc.
*21		1	GEAR BOX, 2000 RPM (Peerless)
22	1927469	1	CAPSCREW, Hex Socket Hd., 1/2-13 x 2-1/4, Gr. 8
23	1709982	1	ADAPTER ASSY.
24	1917356	5	LOCKWASHER, 5/16
25	1960292	1	CAPSCREW, Hex Socket Hd, 5/16-24 x 2-1/4
26	1676998	1	BUSHING
27	1921221	2	CAPSCREW, Hex Hd., 5/16-18 x 1-1/2, Gr. 5
28	1679710	1	SHAFT ASSY.
29	1704314	1	FITTING, Grease w/Ball
30	1676999	1	HUB ASSY.
31	1679101	1	FIELD ASSY.
32	1679104	1	ACCESSORY KIT (3 Springs & 3 Nuts)
33	1685489	1	ROTOR & ARMATURE ASSY.
34	1960074	1	CLIP, Hair Pin
35	1679155	1	DECAL, Rear P.T.O.
36	1917372	4	NUT, Hex Hd., 5/16-18
37	1924361	3	WASHER, Plain, 17/32

\* For Peerless parts breakdown, see page 170. Order Gear Box and component parts from Peerless.

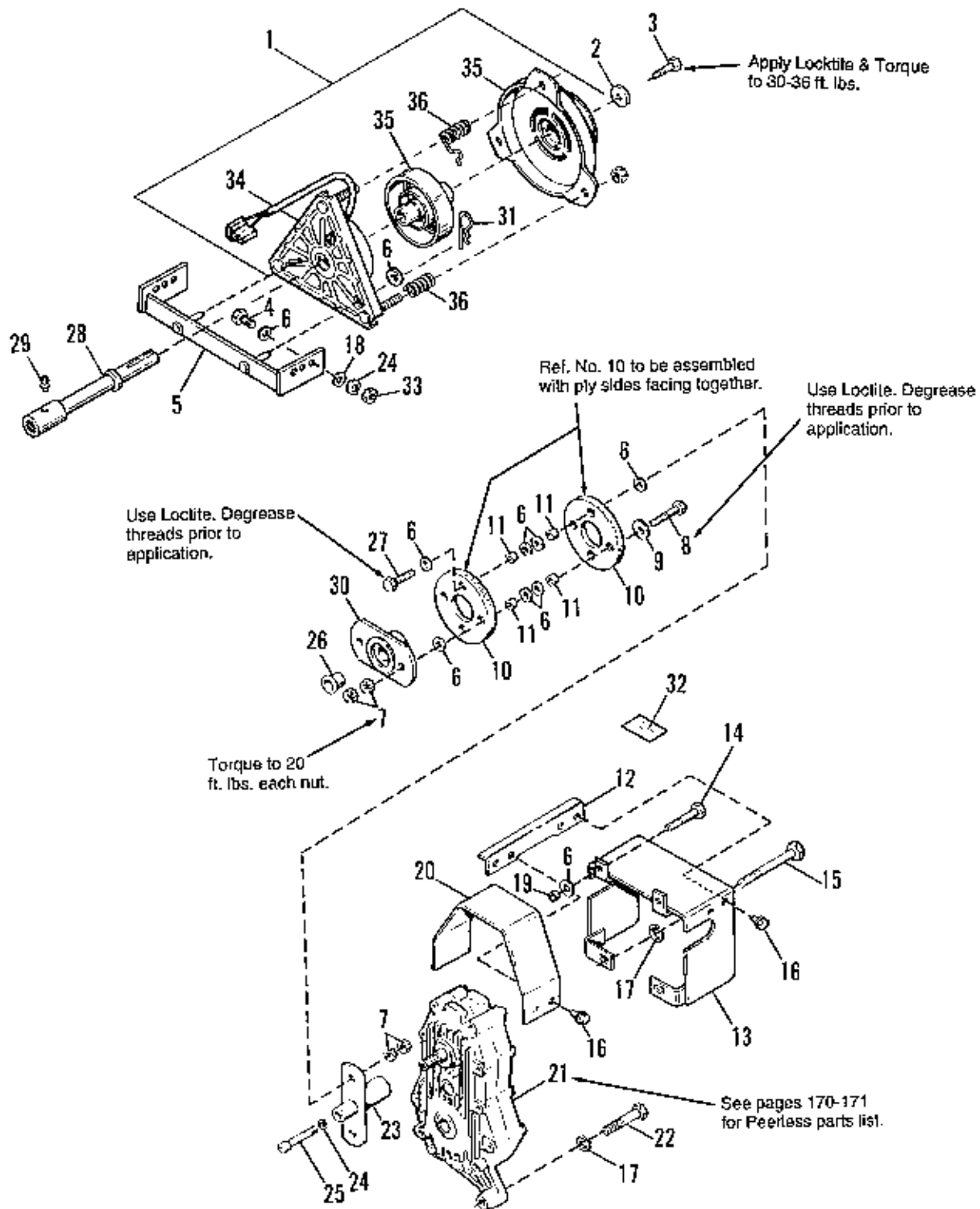

NOTE: Use standard hardware torque spec. chart unless otherwise noted.

Ref. No.	Part No.	Qty.	Description
1	1709199	1	CLUTCH, Electric (Incl. Ref. Nos. 34-36)
2	1708264	1	WASHER
3	1921210	1	CAPSCREW, Hex Hd., 3/8-16 x 1, Gr. 5
4	1921333	4	CAPSCREW, Whizlock, 5/16-18 x 1
5	1709159	1	PLATE ASSY., Rear P.T.O.
6	1919326	29	WASHER, Plain, 11/32 I.D. X 3/4 O.D. X 1/16
7	1923362	8	NUT, Hex, Centerlock, 5/16-18
8	1921978	2	CAPSCREW, Hex Hd., 5/16-18 x 2
9	1933468	2	WASHER, Plain, 5/16 x 1-1/2 x 9/64
10	1676829	2	COUPLING, Flex
11	156150	8	SPACER
12	1679997	2	SUPPORT, P.T.O. Guard
13	1700010	1	GUARD ASSY., P.T.O.
14	1921978	2	CAPSCREW, Hex Hd., 5/16-18 x 2, Gr. 5
15	1926158	2	CAPSCREW, Hex Hd., 1/2-13 x 4, Gr. 8
16	1924856	8	CAPSCREW, Washer Hd., Taptite, 5/16-18 x 1/2
17	1916966	3	LOCKWASHER, 1/2
18	1919381	4	WASHER, Plain, 11/32 X 1
19	1675481	2	SPACER
20	1679998	1	GUARD, Disc.
21		1	GEAR BOX, 2000 RPM (Peerless)
22	1927489	1	CAPSCREW, Hex Socket Hd., 1/2-13 x 2-1/4, Gr. 8
23	1709982	1	ADAPTER ASSY.
24	1917356	5	LOCKWASHER, 5/16
25	1960292	1	CAPSCREW, Hex Hd., 5/16-24 x 2-1/4
26	1676998	1	BUSHING
27	1921221	2	CAPSCREW, Hex Hd., 5/16-18 x 1-1/2, Gr. 5
28	1679710	1	SHAFT ASSY.
29	1704314	1	FITTING, Grease w/Ball
30	1676999	1	HUB ASSY.
31	1960074	2	CLIP, Hair Pin
32	1679155	1	DECAL, Rear P.T.O.
33	1917372	4	NUT, Hex Hd., 5/16-18
34	1709294	1	FIELD ASSY.
35	1709292	1	ROTOR, ARMATURE & BRAKE ASSY.
36	1709293	1	ACCESSORY KIT

For Peerless parts breakdown, see page 170. Order Gear Box and component parts from Peerless.

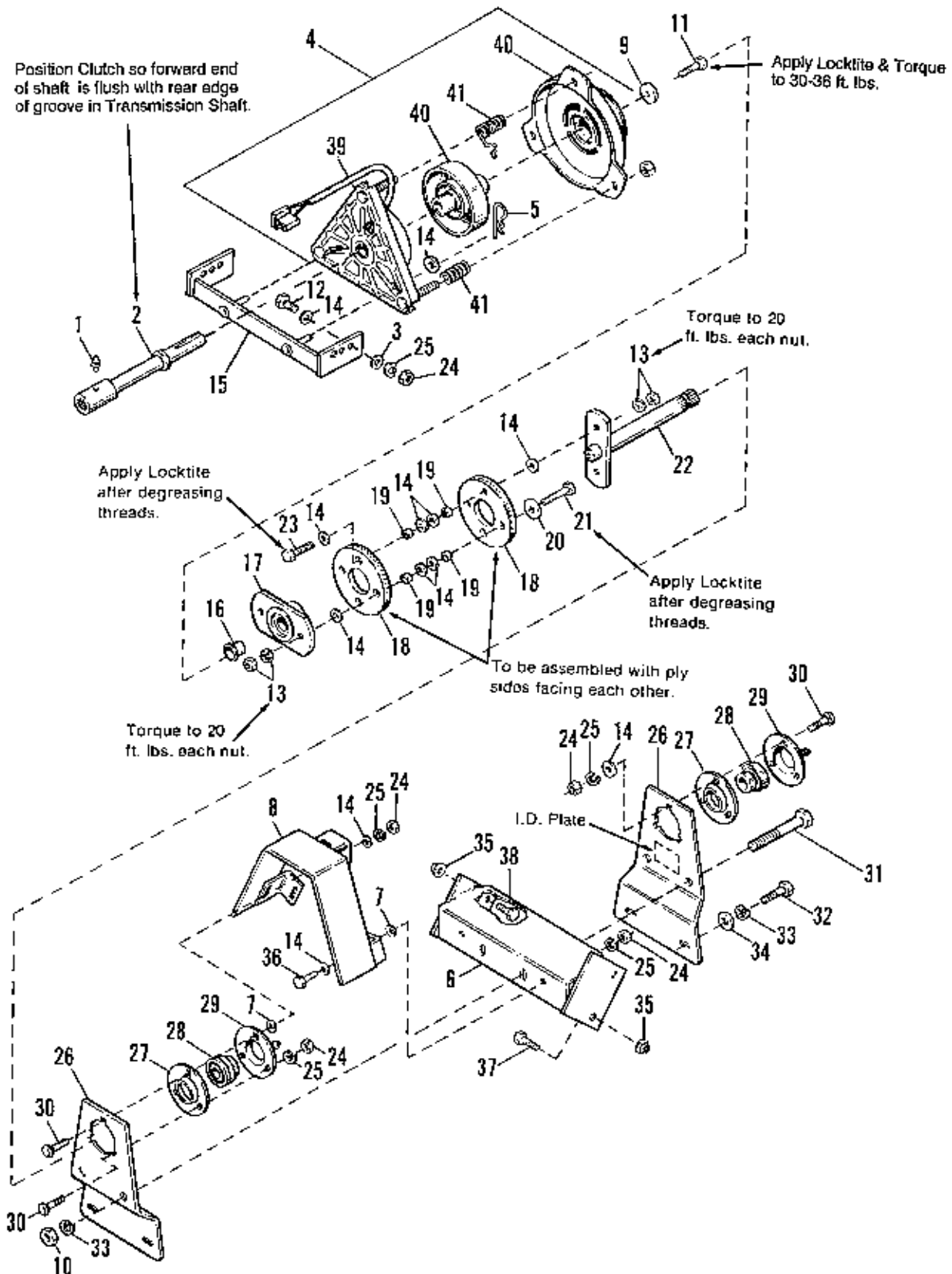

Ref. No.	Part No.	Qty.	Description
1	1704314	1	FITTING, Grease
2	1679710	1	SHAFT ASSY.
3	1919381	4	WASHER, Plain, 11/32 x 1 x 1/8
4	1709199	1	ELECTRIC CLUTCH (Incl. Ref. Nos. 39-41)
5	1960074	2	CLIP, Hair Pin
6	1677004	1	BRACKET ASSY.
7	933988	3	NUT, Push Pal, 5/16
8	1677207	1	GUARD ASSY.
9	1676997	1	WASHER, 13/32 x 1-1/2 x 1/4
10	1916951	2	NUT, Hex, 1/2-13
11	1921210	1	CAPSCREW, Hex Hd., 3/8-16 x 1, Gr. 5
12	1921333	4	CAPSCREW, Hex Hd., 5/16-18 x 1
13	1923362	8	NUT, Hex, Centerlock, 5/16-18
14	1919326	28	WASHER, Plain, 11/32 ID x 3/4 OD x 1/16
15	1709159	1	PLATE ASSY., Rear P.T.O.
16	1676998	1	BUSHING
17	1702011	1	HUB ASSY.
18	1676829	2	FLEX COUPLING
19	156150	8	SPACER
20	1933468	2	WASHER, Plain, 11/32 x 1-1/4 x 1/8
21	1921978	2	CAPSCREW, Hex Hd., 5/16-18 x 2
22	1677002	1	SHAFT ASSY., P.T.O.
23	1921221	2	CAPSCREW, Hex Hd., 5/16-18 x 1-1/2
24	1917372	12	NUT, Hex, 5/6-18
25	1917356	12	LOCKWASHER, Spring, 5/16-18
26	1677009	2	SUPPORT, Rear P.T.O.
27	172278	2	FLANGE, Bearing
28	173934	2	BEARING, Cartridge w/Lock Collar
29	172279	2	FLANGE, Bearing
30	1931335	6	BOLT, Carriage, 5/16-18 x 1
31	1923161	2	CAPSCREW, Hex Hd., 1/2-13 x 4-1/2, Gr. 5
32	1920328	2	CAPSCREW, Hex Hd., 1/2-13 x 1-1/2
33	1916966	4	LOCKWASHER, Spring, 1/2
34	1924361	2	WASHER, Plain, 17/32
35	1935041	4	NUT, Hex, Flange Whiz, 7/16-14
36	1923325	2	CAPSCREW, Hex Hd., 5/16-18 x 7/8, Gr. 5
37	1923451	2	CAPSCREW, 7/16-14 x 1-1/2, Gr. 8
38	1923471	2	CAPSCREW, Hex Hd., 7/16-14 x 1-1/4, Gr. 8
39	1709294	1	FIELD ASSY.
40	1709292	1	ROTOR, ARMATURE & BRAKE ASSY.
41	1709293	1	ACCESSORY KIT

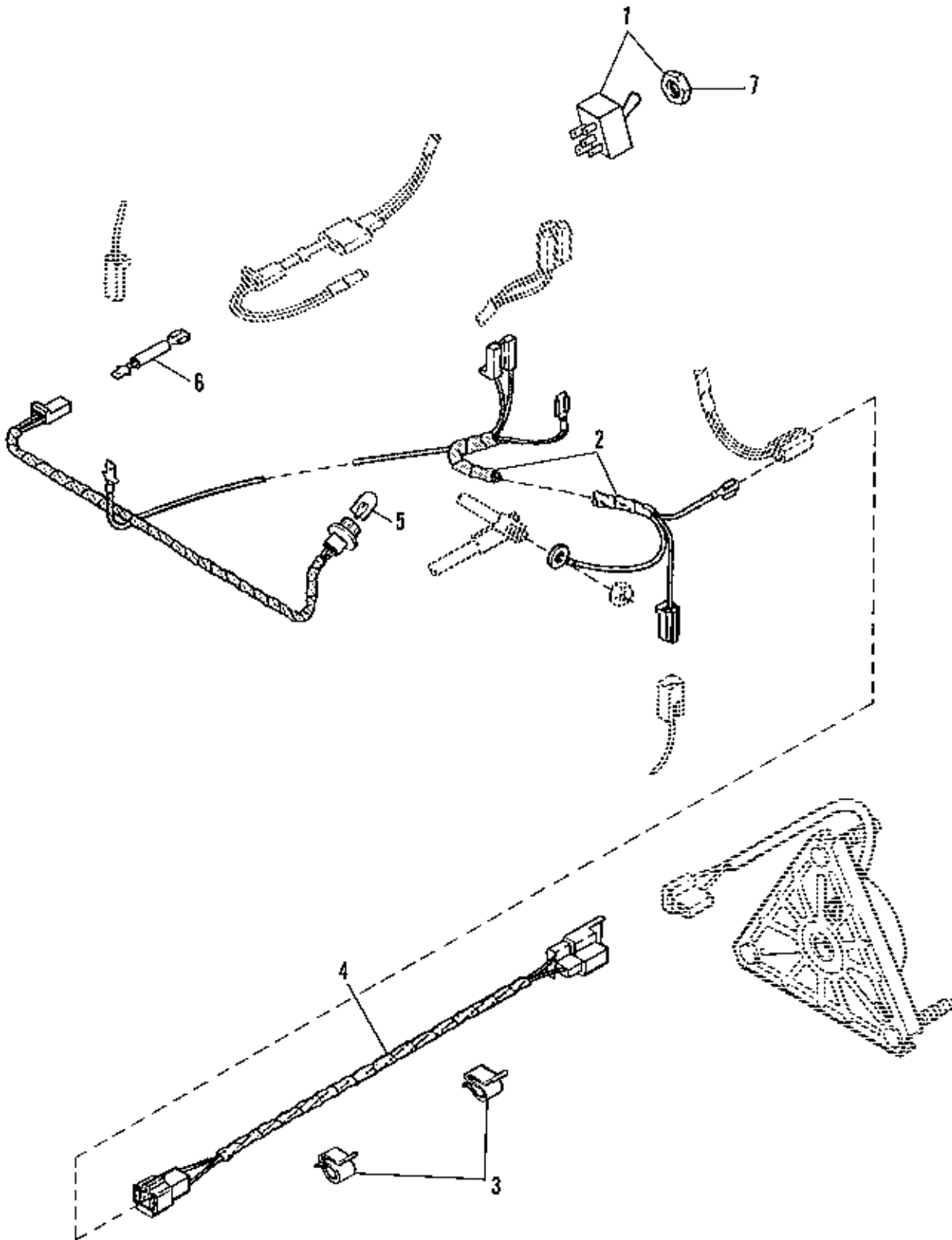

NOTE: Use standard hardware torque spec. chart unless otherwise noted.

Rear P.T.O. Electrical Group

---

Ref. No.	Part No.	Qty.	Description
1	1675800	1	SWITCH ASSY., P.T.O. (Incl. Ref. No. 7)
2	1677494	1	ELECTRICAL HARNESS, Rear P.T.O., Front
3	172494	2	CLIP
4	1677493	1	ELECTRICAL HARNESS, Rear P.T.O., Rear
5	1676130	1	LAMP, Indicator
6	1677484	1	WIRE ASSY., Diode
7	1677663	1	NUT, Hex, 1/2-27

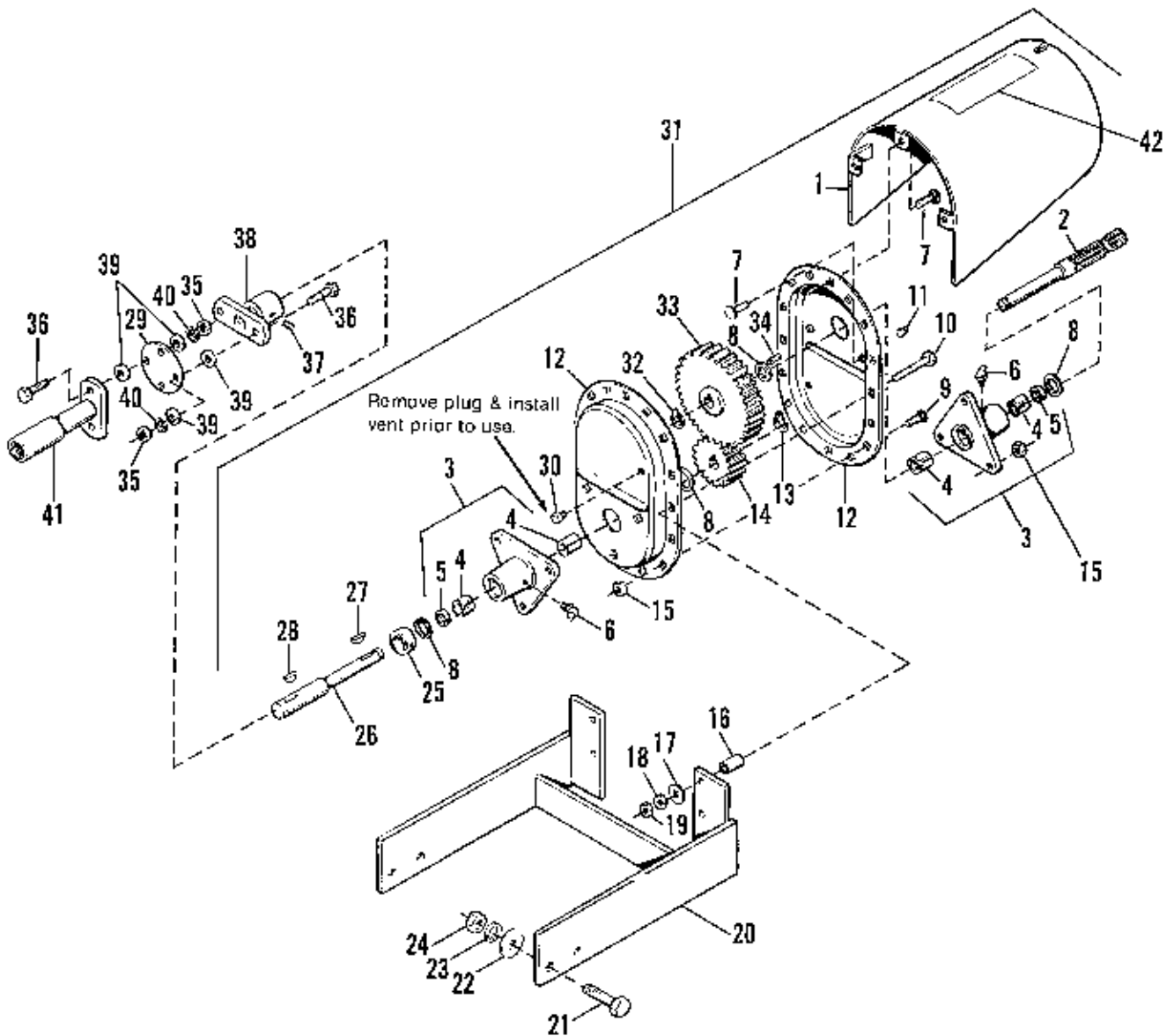

NOTE: Use standard hardware torque spec. chart unless otherwise noted.



Ref. No.	Part No.	Qty.	Description
1	1702181	1	SHIELD ASSY., P.T.O.
2	1702180	1	SHAFT, Output
3	1702176	2	HUB ASSY., w/Bearings & Seal (Incl. Ref. Nos. 4, 5 & 6)
4	173739	4	BEARING, Needle
5	118019	1	OIL SEAL
6	960337	2	FITTING, Grease
7	1931335	9	CARRIAGE BOLT, 5/16 x 1
8	172589	4	WASHER, Thrust
9	1960282	9	CARRIAGE BOLT, 5/16 x 3/4
10	1921719	4	CAPSCREW, Hex Hd., 5/16-18 x 2-1/2
11	920129	1	PLUG
12	1702177	2	COVER, Gear Box (Half)
13	927732	1	RING, Retainer
14	1702178	1	GEAR, Pinion, 18 Teeth
15	919438	18	NUT, Hex Lock, 5/16-18
16	1608310	4	SPACER
17	1919326	4	WASHER
18	1917372	4	NUT, Hex, 5/16-18
19	1920161	4	NUT, Hex, Jam, 5/16-18
20	1701239	1	CARRIER ASSY.
21	1922684	4	CAPSCREW, Hex Hd., 5/8-11 x 2
22	933757	2	WASHER, 5/8
23	1917373	4	LOCKWASHER, 5/8
24	1915726	4	NUT, Hex, 5/8-11
25	1702175	1	COLLAR, Bearing
26	1702174	1	SHAFT, Input
27	905123	1	KEY, Woodruff
28	905126	1	KEY, Woodruff
29	173026	1	COUPLING
30	1678690	1	PLUG, Vent
31	1700753	1	HOUSING ASSY., Reduction w/Shield (Incl. Ref. Nos. 1-9, 11-15, 25-27, & 30-34)
32	1960338	1	RING, Retaining
33	1702179	1	GEAR, Driven, 72 Teeth
34	157652	1	KEY, Parallel
35	1916950	4	NUT, Hex, 5/16-18
36	1920415	4	CAPSCREW, Hex Hd., 5/16-16 x 1-1/4
37	1928721	1	SETSCREW, 5/16-18 x 1/2
38	1676561	1	COUPLER ASSY.
39	157424	8	WASHER, Special
40	1916965	4	LOCKWASHER, 5/16
41	1700745	1	SHAFT ASSY., 540 P.T.O.
42	1700750	1	DECAL, Warning

## Safety Decal



Ref. No. 42

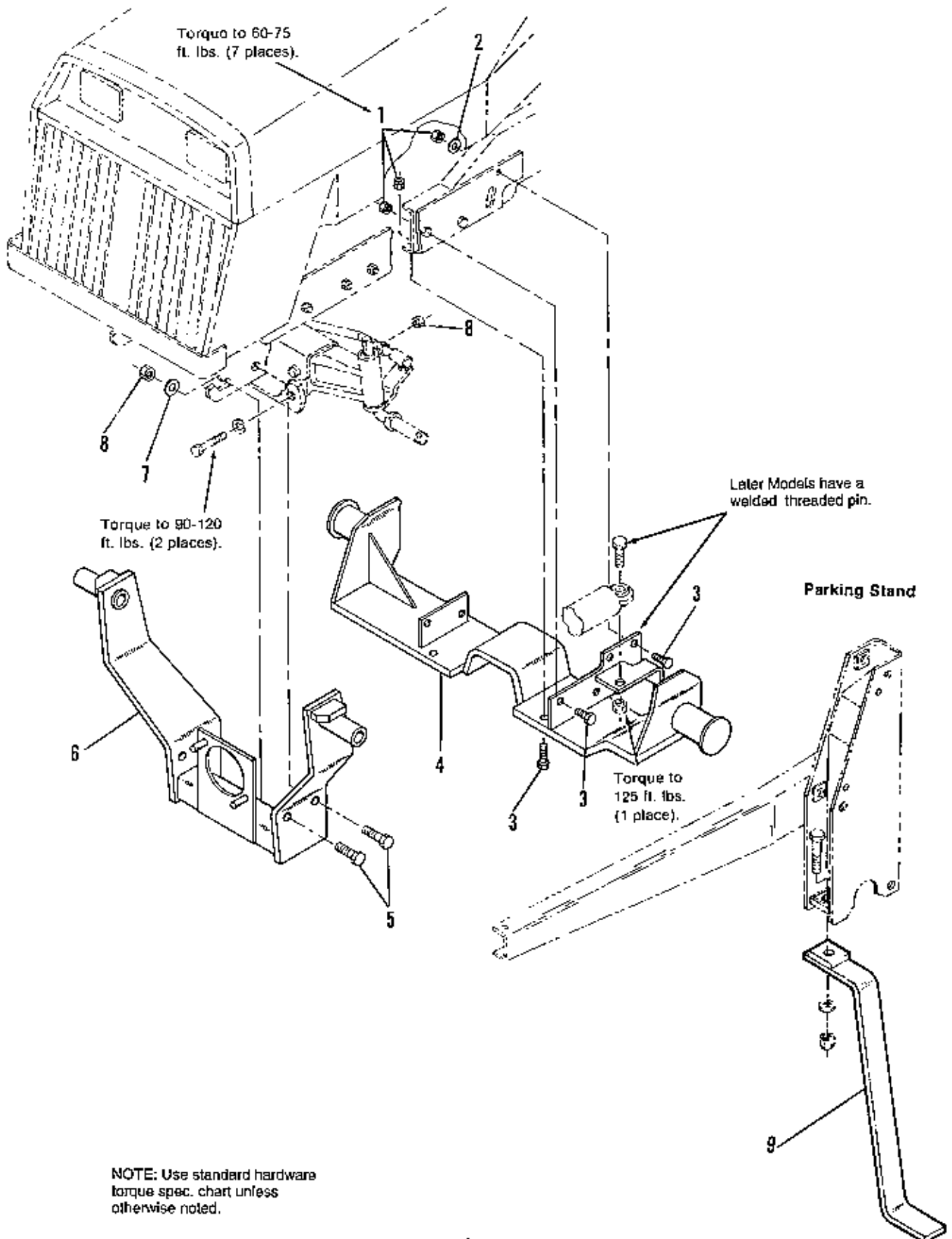

Loader Mounting Kit & Parking Stand

---

Ref. No.	Part No.	Qty.	Description
1	1922134	7	NUT, Centerlock, 1/2-13
2	1960170	1	WASHER, Flat, 1/2 x 1, 12 Ga.
3	1920328	7	CAPSCREW, 1/2-13 x 1-1/2
4	1700522	1	BRACKET, Mid Mounling
5	1922664	4	CAPSCREW, 5/8-11 x 2
6	1700521	1	BRACKET, Front Mounting
7	1960035	2	WASHER, Flat, 5/8
8	1923353	4	LOCKNUT
9	*1700607	2	STAND, Parking (Loader)

\*NOTE: Ref. No. 9 (Qty. 2) can be ordered as wholegoods No. 1691312.

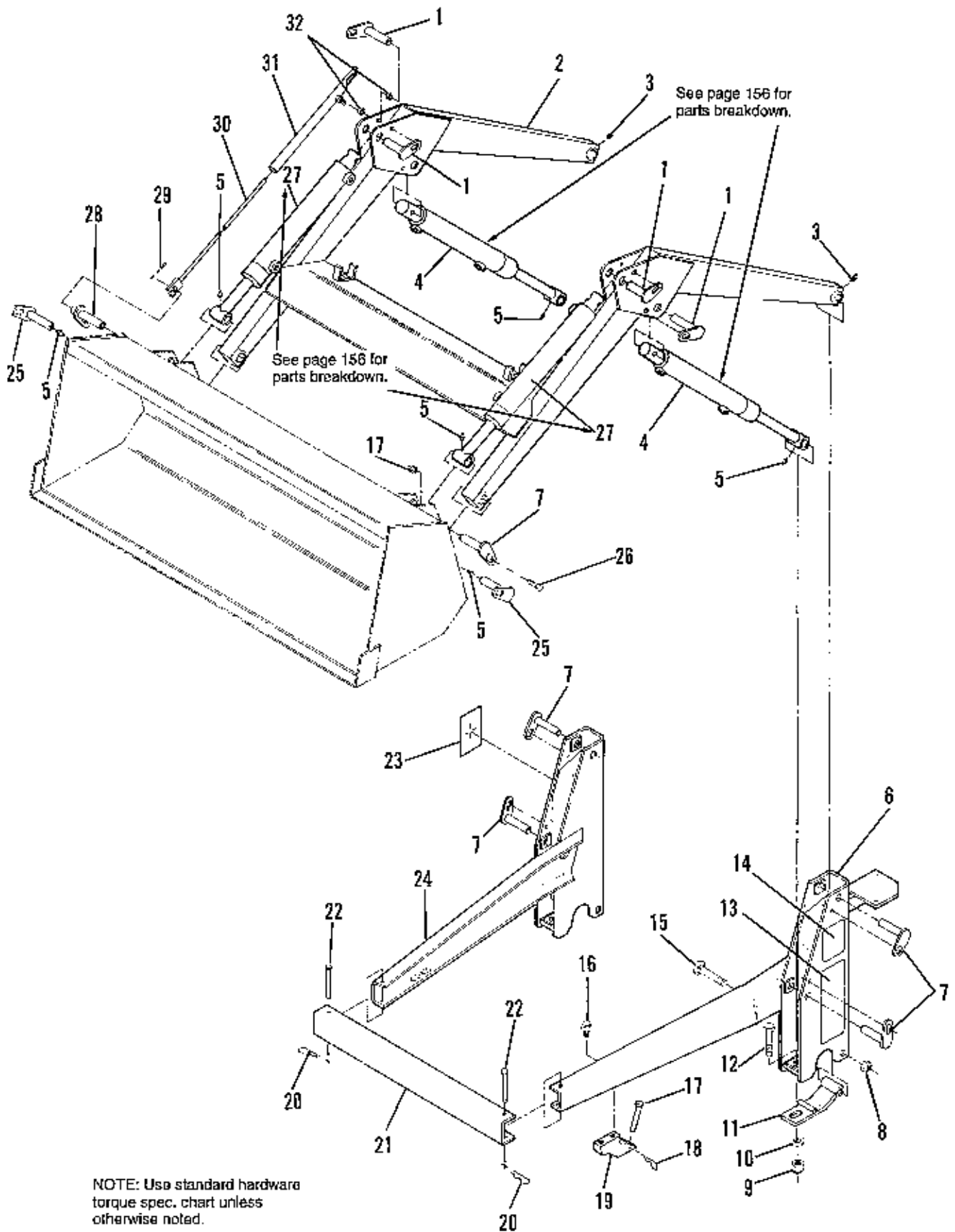

## Loader Main Frame

Ref. No.	Part No.	Qty.	Description
1	1700524	4	PIN ASSY., 3/4 x 2-1/2 (Cyl. Base)
2	1700523	1	FRAME, Lift Boom
3	918186	2	FITTING, Grease, 1/4-28
4	1700535	2	CYLINDER, Lift (Code HG) (See page 156 for parts breakdown.)
5	912808	6	GREASE FITTING, 1/4-28
6	1700539	1	FRAME, Left Side
7	1700534	5	PIN ASSY., 3/4 x 3-1/4 (Frame, L.H.)
8	1923353	2	LOCKNUT, 5/8-11
9	960301	2	LOCKNUT, Elastic, 5/8-11
10	1960035	2	WASHER, Flat, 5/8
11	1700540	2	HINGE
12	1960289	2	CAPSCREW, 5/8-11 x 3"
13	1700559	1	DECAL, Danger
14	1700558	1	DECAL, Caution
15	960300	2	CARRIAGE BOLT, 5/8-11 x 3-3/4, Gr. 5
16	960303	4	CAPSCREW, Serrated Hd., 1/2-13 x 3/4
17	960302	2	PIN, Clevis, 5/8 x 3-1/4
18	1960033	2	PIN, Hair Cotter, 3/32 x 2-11/16
19	1700541	2	HOOK, Side Frame Mounting
20	1960074	2	PIN, Hair Cotter, 3/32 x 1-7/8
21	1700542	1	BUMPER, Front
22	960304	2	PIN, Clevis, 3/8 x 4
23	1700557	1	DECAL, Caution
24	1700538	1	FRAME, Right Side
25	1700533	2	PIN ASSY., 3/4 x 3-1/4 (Bucket)
26	960323	12	BOLT, Shoulder 3/8 x 1
27	1700526	2	CYLINDER, Bucket, (Code HF) (See page 156 for parts breakdown.)
28	1700532	1	PIN ASSY., 3/4 x 3-1/4
29	918454	1	COTTER PIN, 5/32 x 1-1/2
30	1700531	1	ROD, Indicator
31	1700525	1	TUBE, Indicator Guide
32	1930651	13	LOCKNUT, 3/8-16

NOT SHOWN: Hydraulic Oil Flow Restrictor Kit, Part No. 1685300.

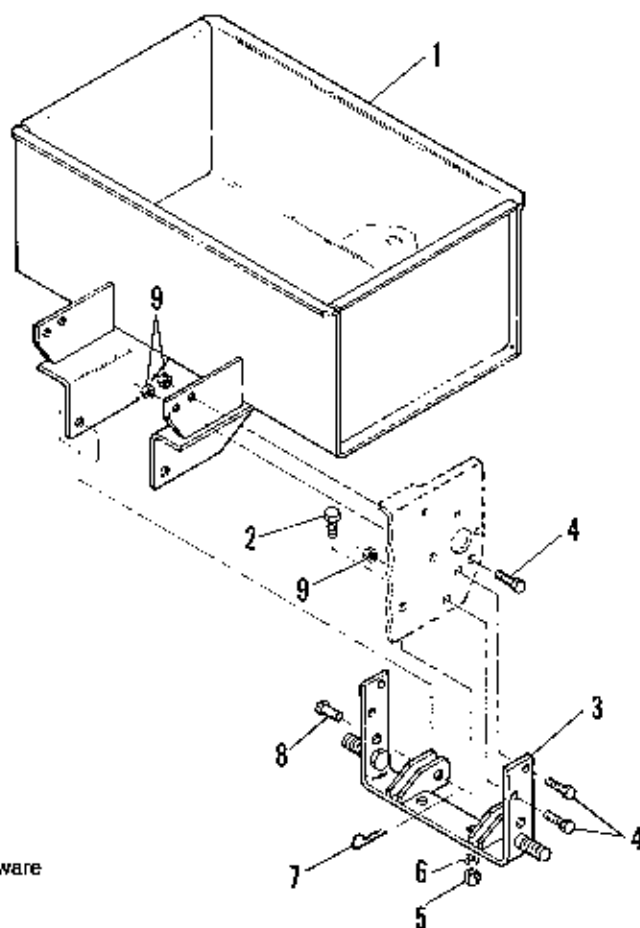
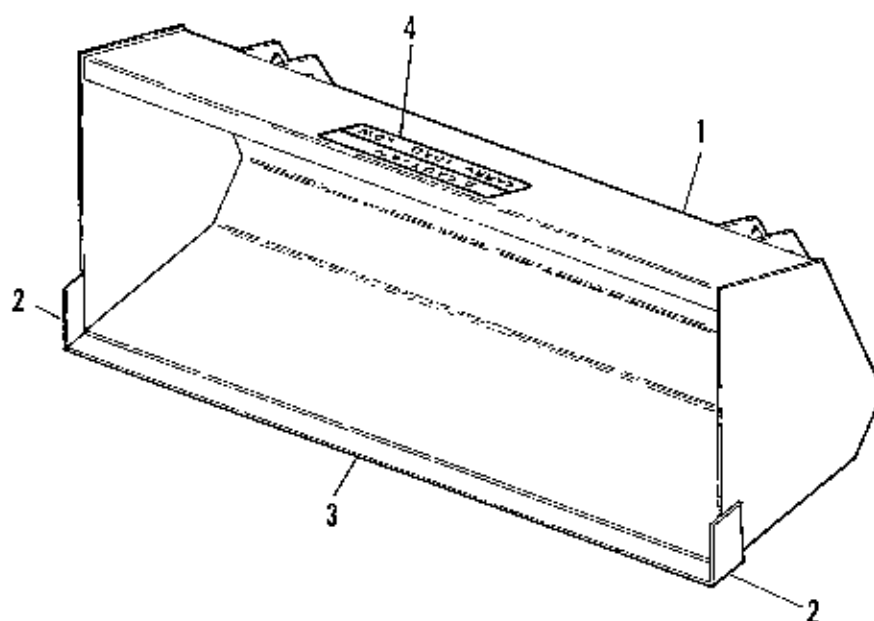

NOTE: Use standard hardware  
torque spec. chart unless  
otherwise noted.

Mfg. No. 1691310 (38"), 1691311 (48")

*Bucket Group*

---

Ref. No.	Part No.	Qty.	Description
*1		1	BUCKET ASSY., 38"
		1	BUCKET ASSY., 48"
2	1700546	2	EDGE, Side Cutting (weld on part)
3	1700547	1	EDGE, 38", Bottom Cutting (weld on part)
	1700548	1	EDGE, 48", Bottom Cutting (weld on part)
4	1700549	1	DECAL, Caution

\*Order complete Bucket from Wholegoods,

1691310	1	38" Bucket
1691311	1	48" Bucket

Mfg. No. 1691309, 1691338

*Ballast Box Group*

---

Ref. No.	Part No.	Qty.	Description
1	1700550	1	BOX, Ballast
*2	1921176	2	CAPSCREW, Hex Hd., 1/2-13 x 1-1/4
*3	1679731	1	BRACKET ASSY., Hitch
4	1920677	6	CAPSCREW, Hex Hd., 7/16-14 x 1-1/4
*5	1916951	2	NUT, Hex, 1/2-13
*6	1916966	2	LOCKWASHER, 1/2
7	1960033	2	PIN, Hair Cotter, 5/32 x 11/16
8	1960116	2	PIN, Clevis, 1/2 x 1-15/16
9	1924058	6	LOCKNUT, 7/16-14

\*Not used on Mfg. No. 1691338

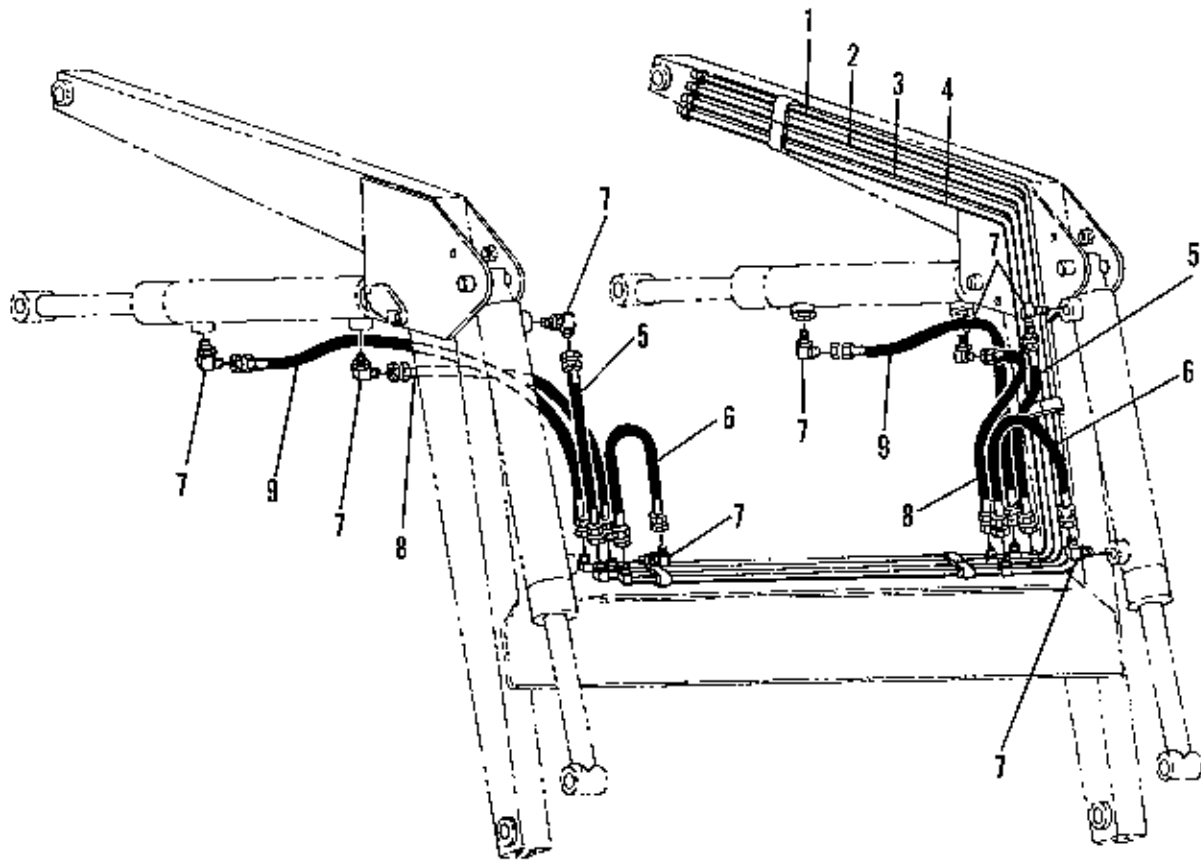

NOTE: Use standard hardware  
torque spec. chart unless  
otherwise noted.



Hydraulic Group, Frame

---

Ref. No.	Part No.	Qty.	Description
1	1700511	1	TUBE, Oil Line, TCR
2	1700512	1	TUBE, Oil Line, TCB
3	1700513	1	TUBE, Oil Line, LOB
4	1701011	1	TIE, Self-Locking
5	1700518	2	HOSE, 1/4 x 10-1/2"
6	1700519	2	HOSE, 1/4 x 15"
7	922523	8	FITTING, Elbow Adaptor, 9/16 - 9/16 x 90
8	1700517	2	HOSE, 1/4 x 16"
9	1700516	2	HOSE, 1/4 x 30"

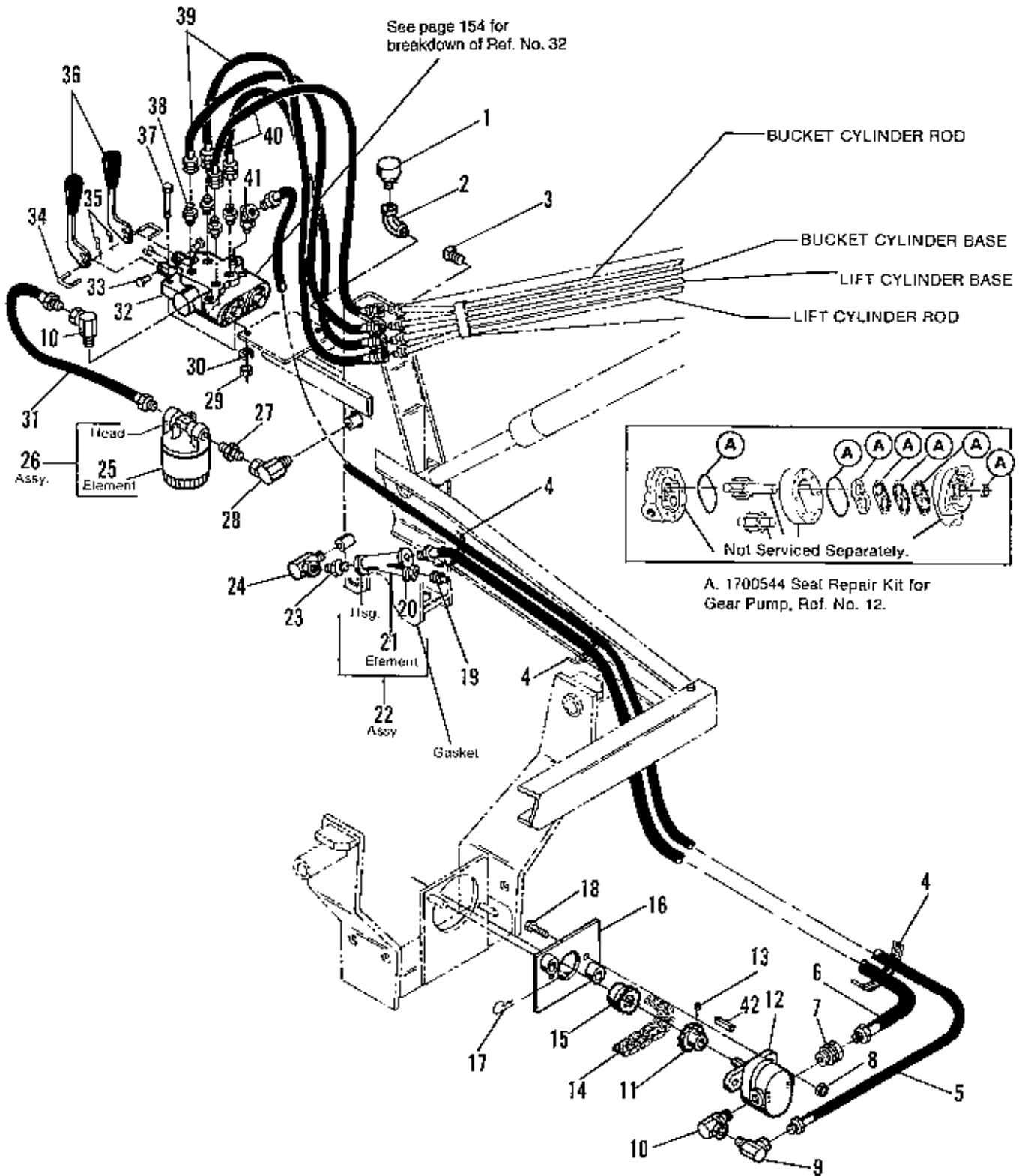

NOTE: Use standard hardware torque spec. chart unless otherwise noted.

Ref. No.	Part No.	Qty.	Description
1	1700509	1	CAP, Breather
2	1700510	1	FITTING, Street Elbow, 1/2 x 90°
3	905261	1	PLUG, Pipe, 1/2
4	925442	3	STRAP, Adjustable Tie, 3/16 x 14-3/16
5	1700489	1	HOSE, 3/8 x 72"
6	1700496	1	HOSE, 1/2 x 48"
7	1700492	1	FITTING, Adaptor Union, 7/8 - 1/2
8	1930651	2	LOCKNUT, 3/8-16
9	1700488	1	FITTING, Elbow Adaptor, 3/8 - 3/8 x 90°
10	1700487	2	FITTING, Elbow Adaptor, 3/4 - 3/8 x 90°
11	1700486	1	SPROCKET, w/Keyway Hub, #40B12
*12	1700493	1	GEAR PUMP
13	1930545	1	SETSCREW, Skt. Hd., 1/2-20 x 1/4
14	1700485	1	CHAIN, Roller, #40-2 x 12
15	1700484	1	SPROCKET, w/Spline Hub, #40B12
16	1700494	1	BRACKET, Pump Mounting
17	1960074	2	PIN, Hair Cotter, 3/32 x 1-7/8
18	1920415	2	CAPSCREW, 3/8-16 x 1-1/4
19	1673452	1	PLUG, Pipe, 3/8
20	1700601	1	GASKET (Y-Strainer)
21	1700600	1	SCREEN, Replacement (Y-Strainer)
22	1700490	1	Y-STRAINER
23	1700491	1	FITTING, Adaptor, 1/2 - 1/2
24	1700487	1	FITTING, Elbow Adaptor, 1/2 - 1/2 x 90°
25	1700603	1	ELEMENT, Filter, 10 Micron
26	1700500	1	FILTER ASSY., w/ Element
27	1700499	1	FITTING, Adaptor, 3/8 - 3/8
28	1700498	1	FITTING, Elbow Adaptor, 1/2 - 3/8 x 90°
29	1916622	2	NUT, Hex, 1/4-20
30	1916964	2	LOCKWASHER, 1/4
31	1700501	1	HOSE, 3/8 x 14"
32	1700502	1	VALVE ASSY. (See page 154 for parts breakdown.)
33	1960261	2	PIN, 1/4 x 3/4
34	1700504	2	V-HOOK
35	1918445	4	PIN, Cotter
36	1700505	2	HANDLE, Valve
37	1921159	2	CAPSCREW, 1/2-20 x 2-1/4
38	922522	4	FITTING, Adaptor, 9/16-9/16
39	1700507	2	HOSE, 1/4 x 22-1/2
40	1700508	2	HOSE, 1/4 x 20"
41	1700503	1	FITTING, Adaptor Union, 3/4 x 3/8 x 45°
42	905121	1	KEY, Woodruff, #5, 1/8 x 5/8
	<b>REPAIR KIT</b>		
*A	1700544	1	SEAL REPAIR KIT

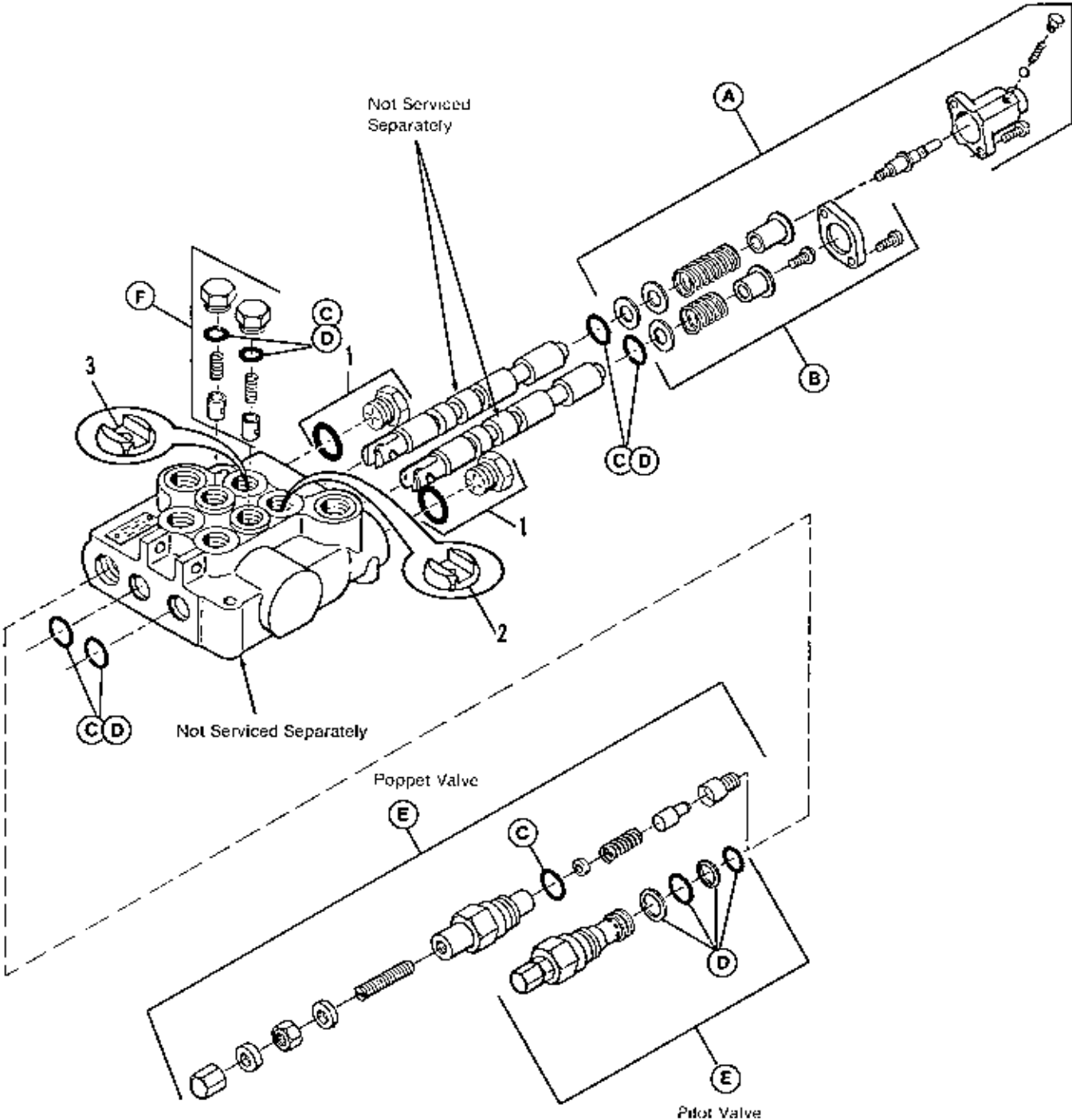

NOTE: Use standard hardware torque spec. chart unless otherwise noted.

## Control Valve Group

Ref. No.	Part No.	Qty.	Description
<b>Parts Breakdown for Control Valve, Part Number 1700502</b>			
1	1700602	2	PLUG, 9/16
2	1700838	1	PLATE, 2-Way Restrictor w/ 1/16 Hole
3	1700837	1	PLATE, 1-Way Restrictor w/ 7/64 Hole
<b>Repair Kits</b>			
A	1700841	1	DETENT SPRING CENTERING KIT
B	1700642	1	SPRING CENTERING KIT
C	* 1700495	1	SEAL REPAIR KIT
D	** 1704147	1	SEAL REPAIR KIT
E	* 1700836	1	POPPET RELIEF VALVE KIT
	** 1704148	1	PILOT RELIEF VALVE KIT
F	1700545	2	LOAD CHECK PLUG KIT

\* Used on Control Valve from serial no. 51001 to serial no. 51051.

\*\* Used on Control Valve after serial no. 51051.

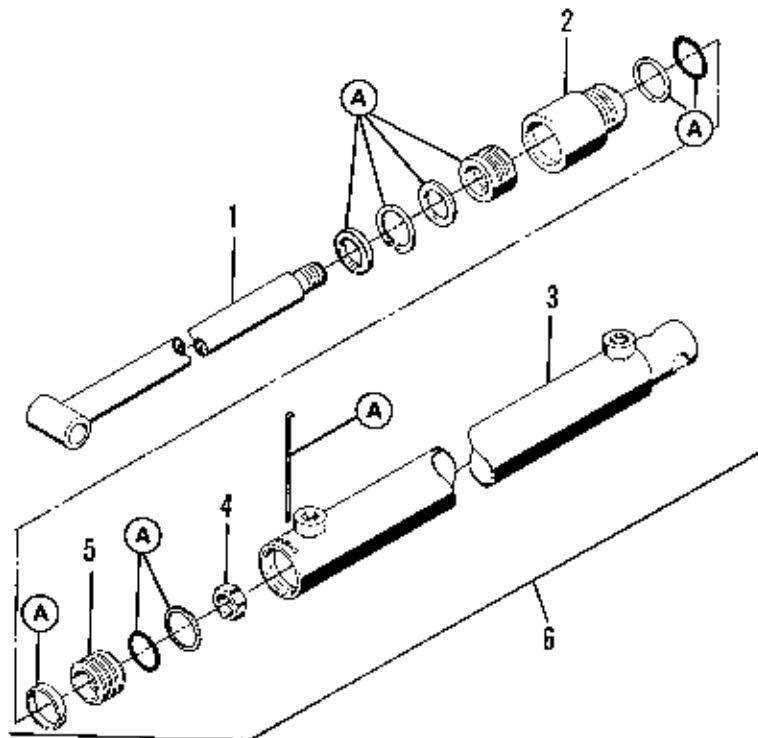
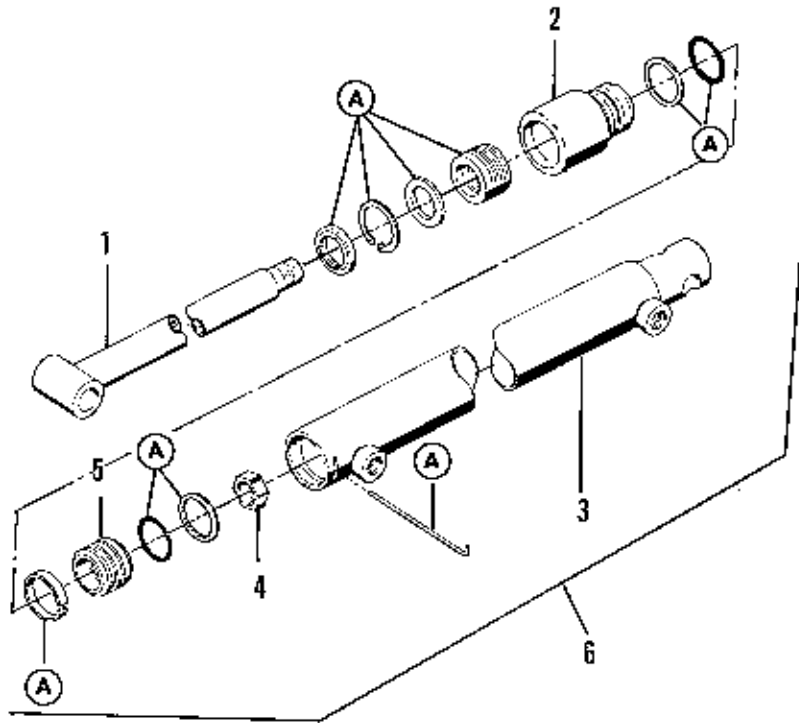

NOTE: Use standard hardware  
torque spec. chart unless  
otherwise noted.

Mfg. 1691309

Cylinder Assy. - Bucket

---

Ref. No.	Part No.	Qty.	Description
1	1700527	1	SHAFT, Cylinder
2	1700528	1	HEAD, Cylinder
3	1700530	1	TUBE, Cylinder
4	960305	1	LOCKNUT, Jam, 3/4-10
5	1700529	1	PISTON, Cylinder
6	1700535		COMPLETE CYL. ASSY. (BUCKET)
	<b>REPAIR KIT</b>		
A	1700646	1	SEAL REPAIR KIT

Mfg. No. 1691309

Cylinder Assy. - Lift

---

Ref. No.	Part No.	Qty.	Description
1	1700536	1	SHAFT, Cylinder
2	1700528	1	HEAD, Cylinder
3	1700537	1	TUBE, Cylinder
4	960305	1	LOCKNUT, Jam, 3/4-10
5	1700529	1	PISTON, Cylinder
6	1700535		COMPLETE CYL. ASST. LIFT
	<b>REPAIR KIT</b>		
A	1700464	1	SEAL REPAIR KIT

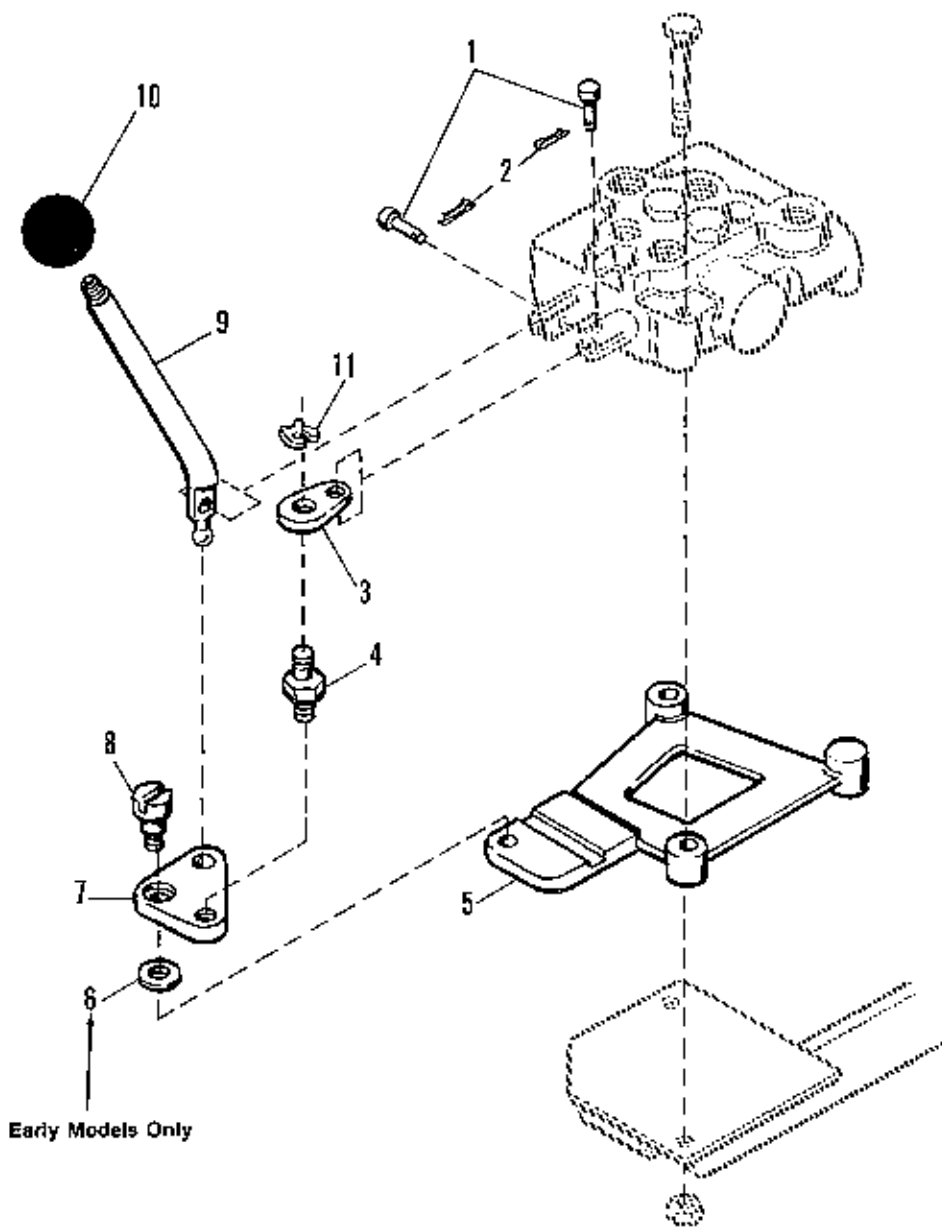

Early Models Only

NOTE: Use standard hardware torque spec. chart unless otherwise noted.



Single Lever Control (Loader)

---

Ref. No.	Part No.	Qty.	Description
1	1960261	2	PIN, Spool, 1/4 x 3/4
2	1918445	2	PIN, Cotter, 1/16 x 1/2
3	1700555	1	LINK, Spool
4	1700556	1	STUD, Pivot Plate
5	1700551	1	PLATE, Lever Mounting
6	1700596	1	WASHER, Curved Spring
7	1702312	1	PLATE, Lever Pivot
8	1700597	1	SCREW, Shoulder
9	1700553	1	LEVER, Valve
10	1700554	1	KNOB, Lever Replacement
11	1700598	1	CLIP, Retainer

DUAL BRAKE PEDALS

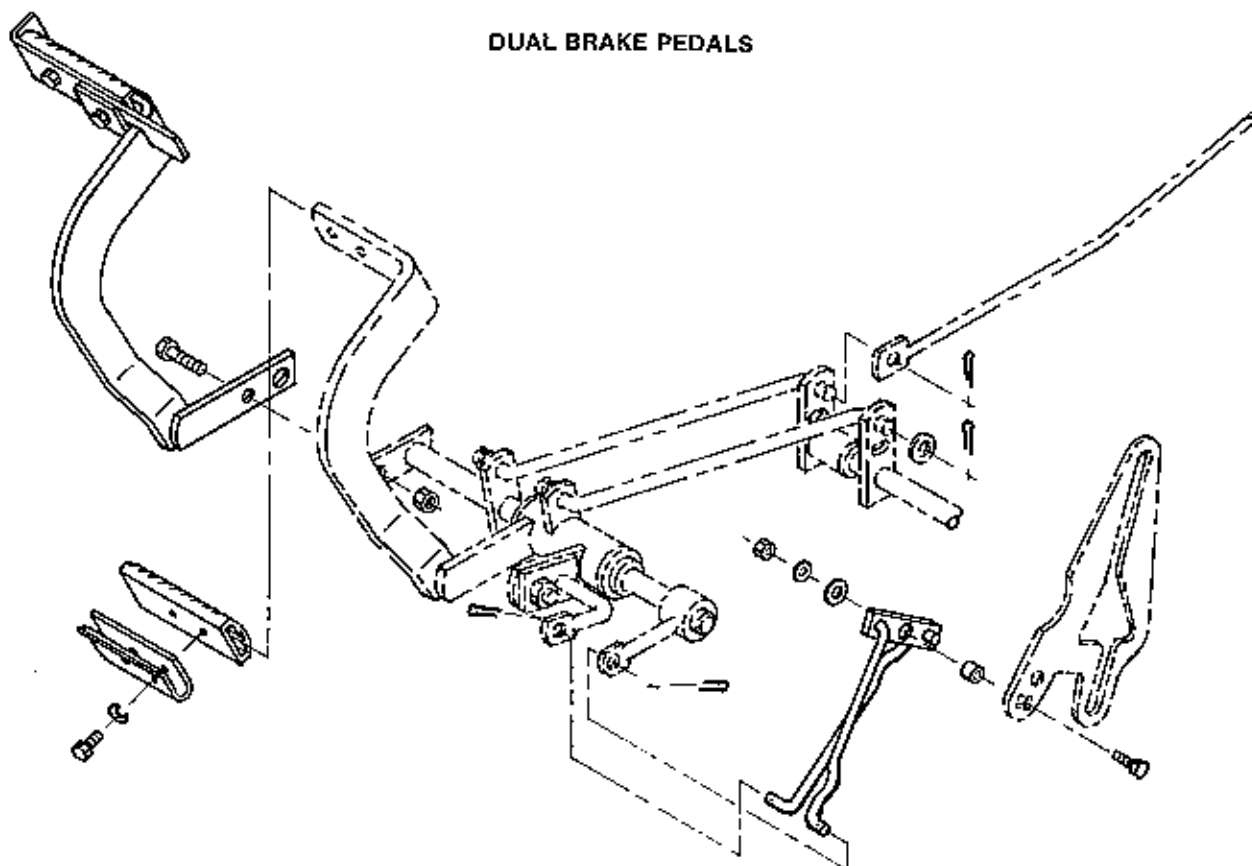

MODIFIED BRAKE FOR  
USE WITH LOADER

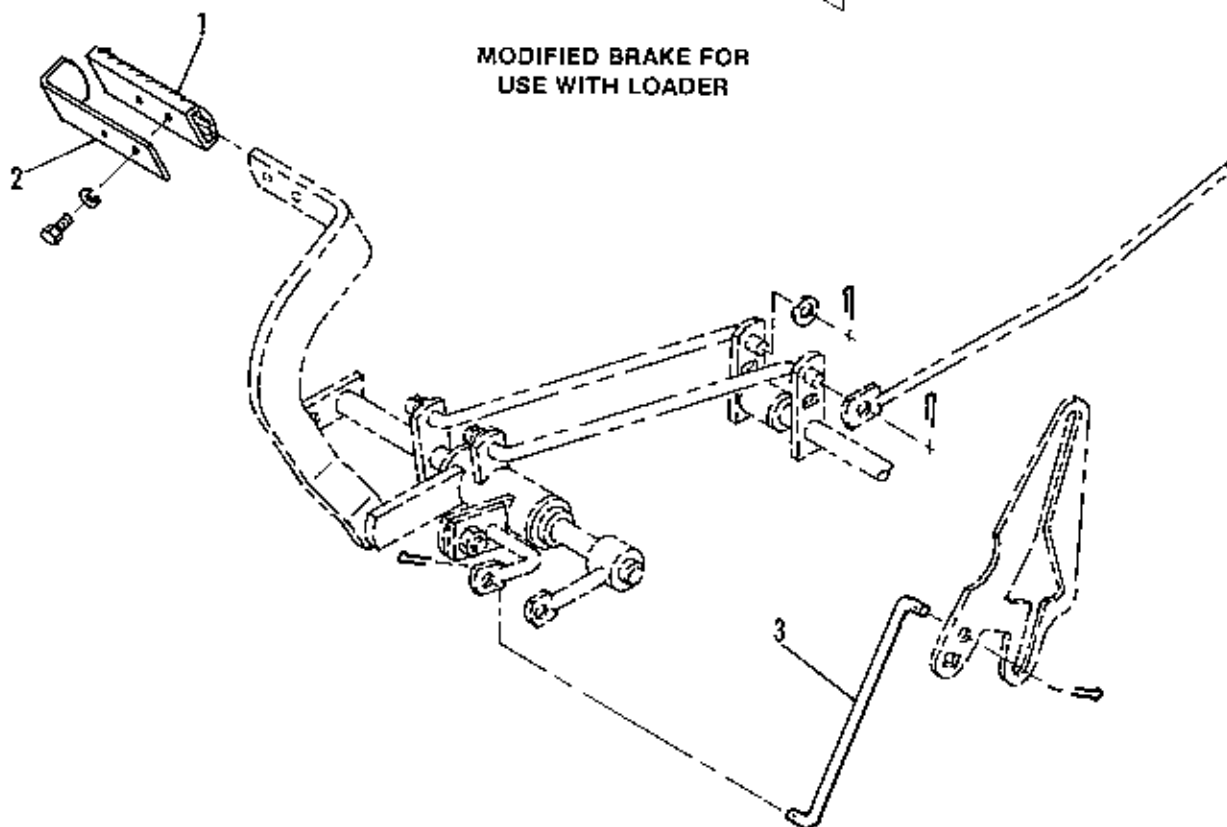

NOTE: Use standard hardware  
torque spec. chart unless  
otherwise noted.

*Pedal Group (Used with 20 HP)*

---

<b>Ref. No.</b>	<b>Part No.</b>	<b>Qty.</b>	<b>Description</b>
1	1678489	1	PAD, Pedal
2	1678488	1	SUPPORT, Pedal
3	1674732	1	ROD, Ground Speed Control

**NOTE:** When the loader is used on a tractor with dual brake pedals, it must be modified to a single brake pedal as shown in illustration.

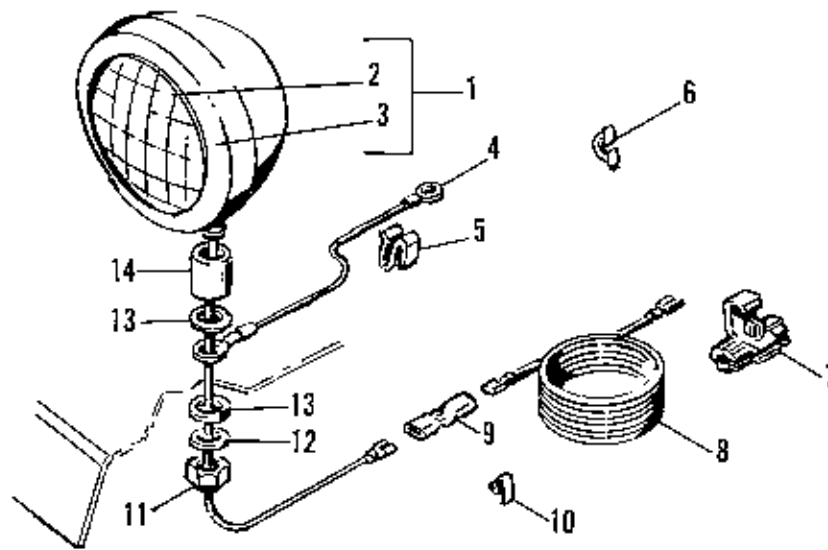

**NOTE:** Use standard hardware torque spec. chart unless otherwise noted.

Rear Light Kit

---

Ref. No.	Part No.	Qty.	Description
1	122175	1	LAMP ASSY.
2	122164	1	LAMP, Seal Beam
3	1679887	1	RING
4	1679160	1	WIRE, Rear Light Ground
5	172434	2	CLIP, Wire
6	934683	1	CLIP, Wire
7	1605751	1	CONNECTOR
8	122187	1	WIRE
9	122157	1	CONNECTOR
10	122159	1	CLIP, Wire
11	1916951	1	NUT, Hex, 1/2-13, Unc 2B, Steel
12	1916966	1	LOCKWASHER, Spring, 1/2, Pltd.
13	1924361	2	WASHER, Plain, 7/16
14	122053	1	SPACER

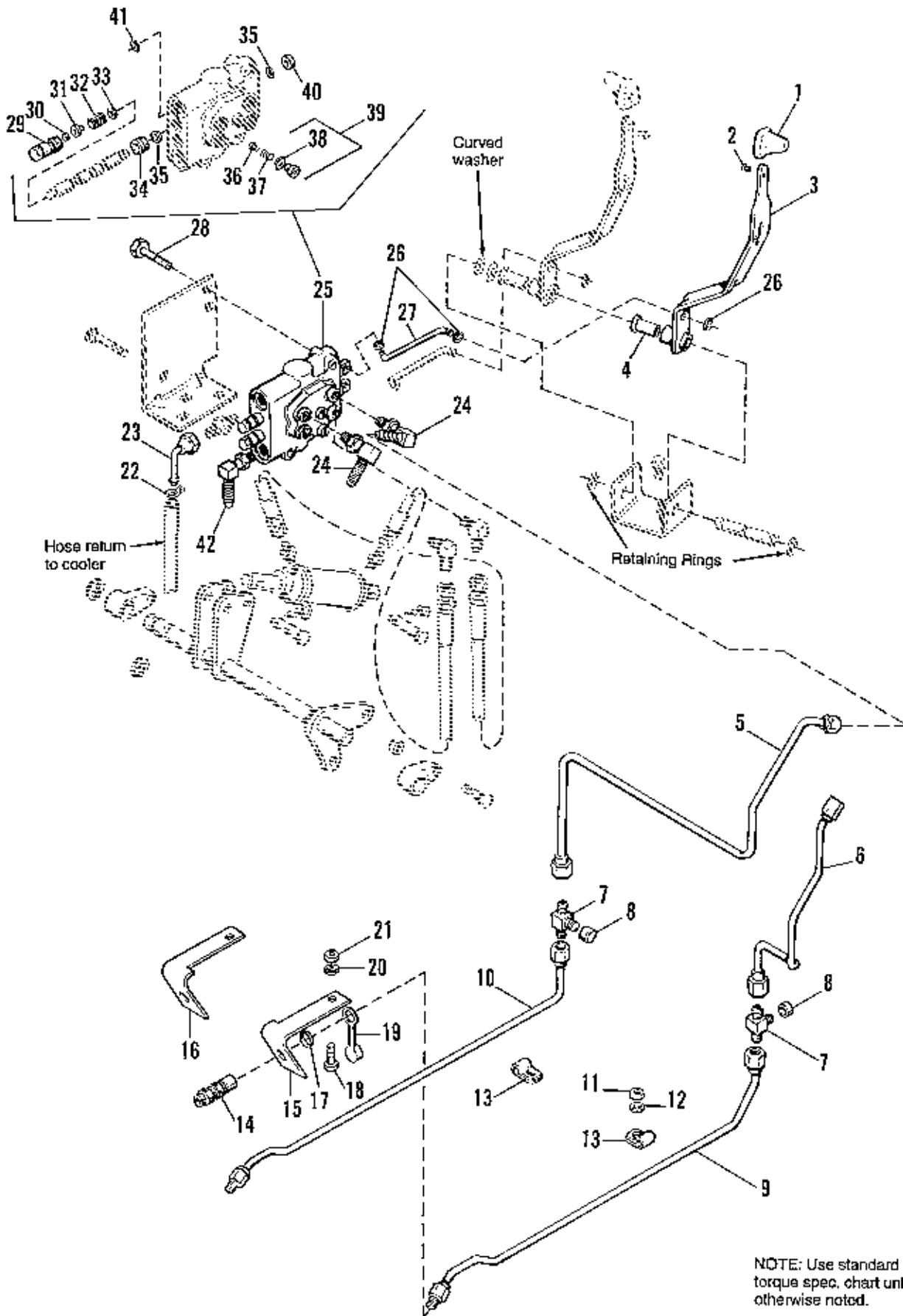

NOTE: Use standard hardware torque spec. chart unless otherwise noted.

## Hydraulic Implement Lift Kit

Ref. No.	Part No.	Qty.	Description
1	171165	1	KNOB, Control Handle
2	1960106	1	SCREW, Plastite, 1/4 x 1
3	1675969	1	CONTROL LEVER ASSY.
4	175731	1	BUSHING
5	1676401	1	TUBE ASSY.
6	1676400	1	TUBE ASSY.
7	1700033	2	UNION, Tee, 3/7
8	1700125	2	CAP
9	1700460	1	TUBE ASSY.
10	1674734	1	TUBE ASSY.
11	1922007	2	NUT, Hex Jam, 5/16-14
12	1909509	2	LOCKWASHER, Int. Tooth
13	1677267	2	CLIP, Tube
14	173358	2	BODY ASSY., Female
15	1677105	1	BRACKET, Quick Disconnect, L.H.
16	1677104	1	BRACKET, Quick Disconnect, R.H.
17	168017	2	RING, Retaining
18	1921210	1	CAPSCREW, Hex Hd., 3/8-16 x 1
19	173360	2	PLUG, Plastic
20	1916965	1	LOCKWASHER, 3/8
21	1916950	1	NUT, Hex, 3/8-16
22	166044	1	CLAMP, Hose
23	1701406	1	FITTING, 90 Swivel
24	1675789	2	FITTING, 90
*25	1708186	1	VALVE ASSY., 2 Spool (Incl. Ref. Nos. 29-41)
26	927789	2	RING, Retaining
27	1679083	1	LINK, Control
28	1921963	1	CAPSCREW, Hex Hd., 1/4-20 x 2
29	1673834	2	CAP
30	1673837	2	RING, Retaining
31	1673833	2	SPACER, Spool
32	1673835	2	SPRING
33	1673836	2	WASHER
34	174187	2	BUSHING
35	1679142	4	"O" RING
36	174130	2	PLUNGER
37	174134	2	SPRING
38	174133	2	"O" RING
39	174131	2	PLUG ASSY.
40	1679138	2	WIPER, Seal
41	1667825	2	"O" Ring
42	921409	1	FITTING, Hyd. Short 1/2" tube x 3/4-16 (For use with Early Model Tractors with 9/16-18 Valve Port)

\*Standard Seal Repair Kit - 1679733

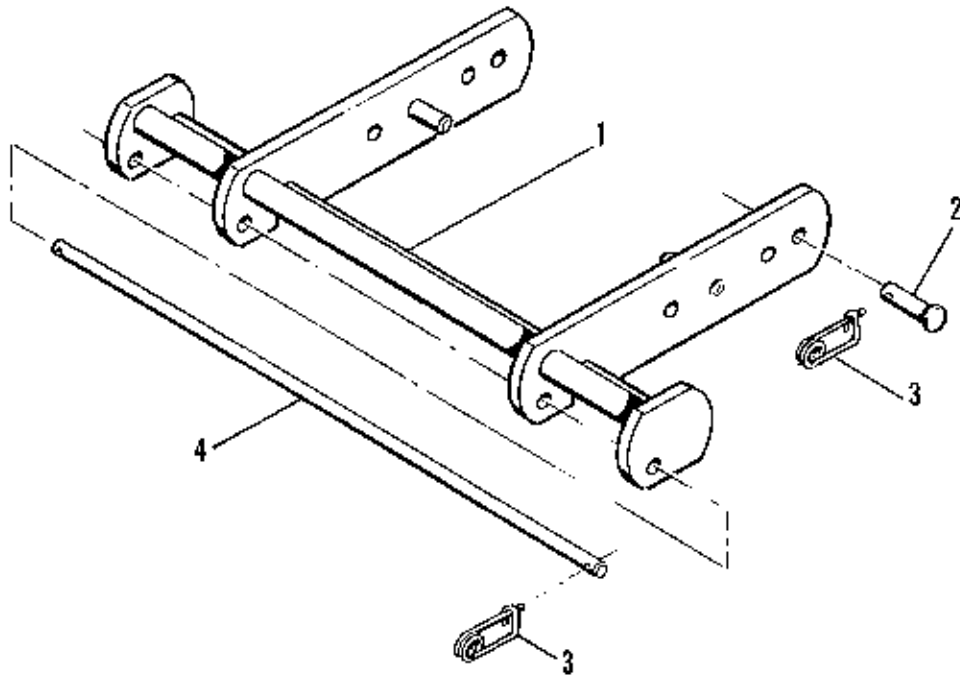

NOTE. Use standard hardware torque spec. chart unless otherwise noted.

Rear Weight Carrier Hitch Group

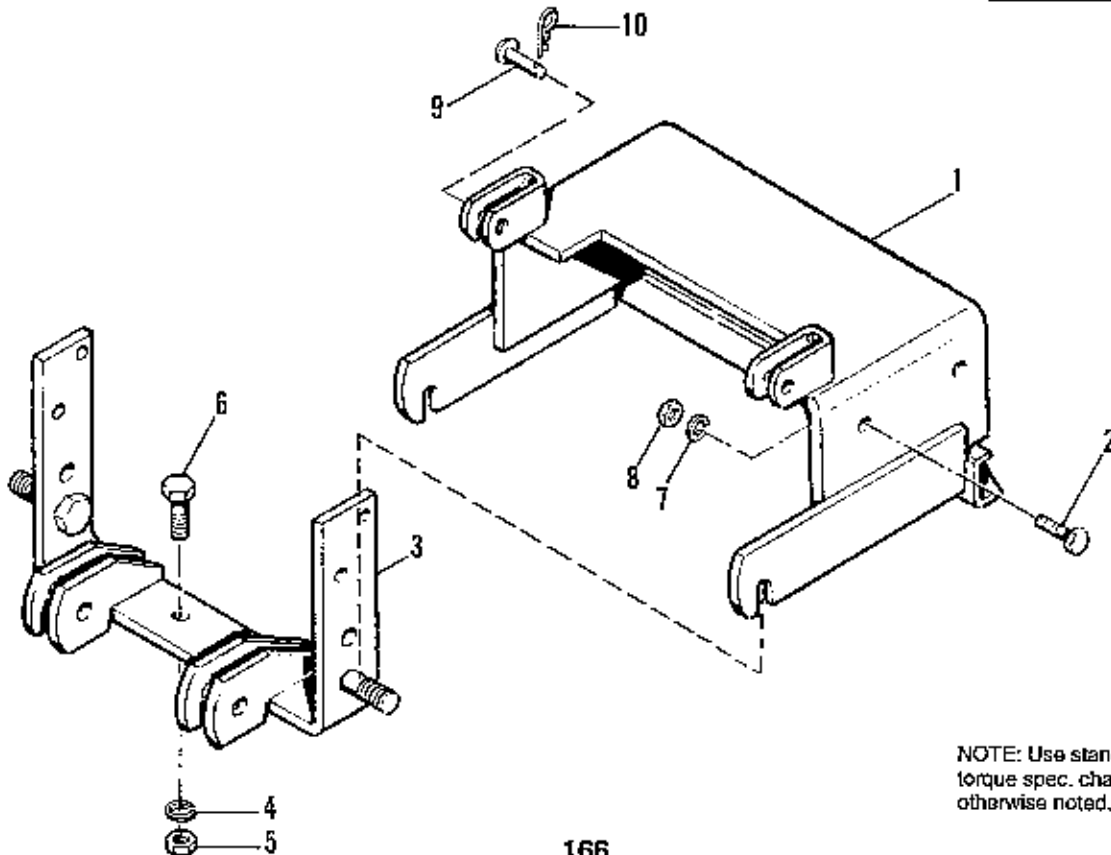

NOTE: Use standard hardware torque spec. chart unless otherwise noted.



Mfg. No. 1691317

Front Weight Carrier

---

Ref. No.	Part No.	Qty.	Description
1	1700007	1	CARRIER ASSY.
2	1960038	2	PIN, Clevis
3	176012	4	CLIP, Pin, Safety
4	1700004	1	ROD, Weight Hold Down

Mfg. No. 1691316

Rear Weight Carrier Hitch Group

---

Ref. No.	Part No.	Qty.	Description
1	1700008	1	HITCH ASSY.
2	1920677	8	CAPSCREW, Hex Hd., 7/16 x 14 x 1-1/4
3	1679731	1	BRACKET ASSY.
4	1916966	2	WASHER, Lock
5	1916951	2	NUT, Hex, 1/2-13
6	1921176	2	CAPSCREW, Hex Hd., 1/2-13 x 1/4
7	1918199	8	WASHER, Lock, 7/16
8	1918213	8	NUT, Hex, 1/2-13
9	8271015	2	PIN, Clevis
10	1918196	2	PIN, Quick

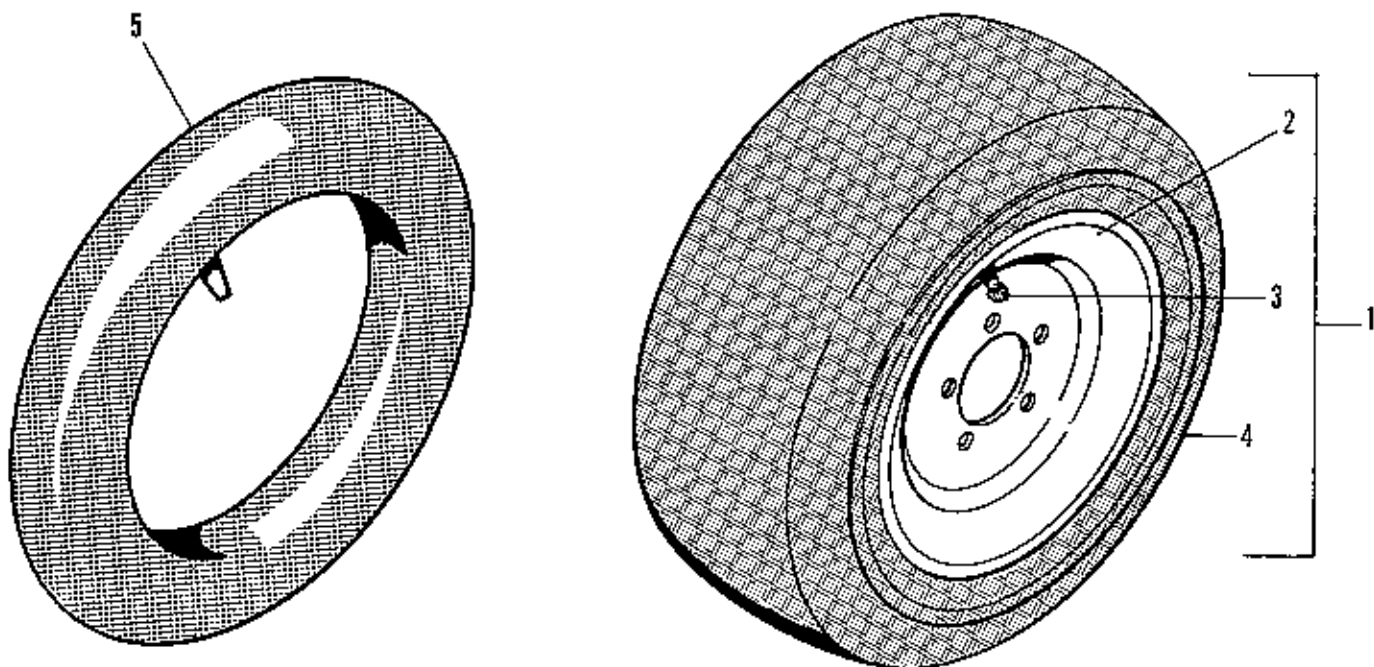
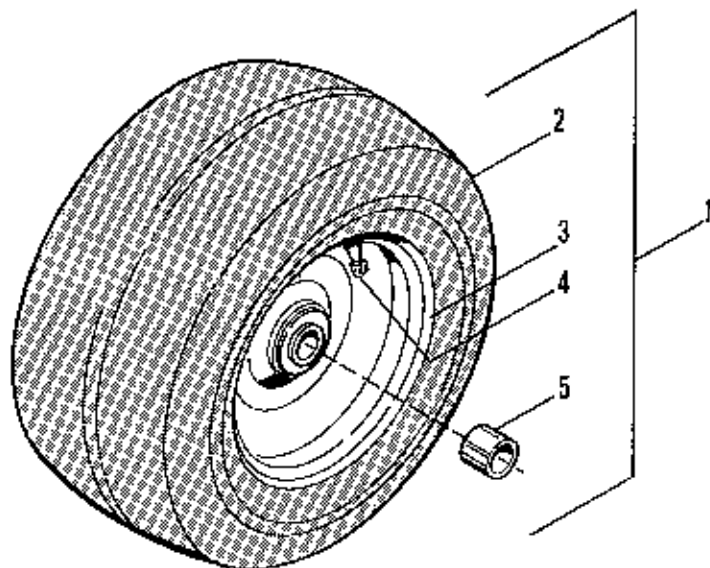

Mfg. No. 1691359, 1691929, 1691930

Front Tire (Hi-Cap Steering) Group

---

	Ref. No.	Part No.	Qty.	Description
Mfg. No. 1691359	1	1700844	2	WHEEL & TIRE ASSY, 16 x6.50-8, 4 Ply
	2	1700842	2	TIRE, 16 x 6.50-8, 4 Ply
	3	1669851	2	RIM ASSY. (Incl. Ref. No. 5)
	4	172353	2	VALVE STEM & CAP
	5	1704867	4	BEARING, 1" Bore
	Ref. No.	Part No.	Qty.	Description
Mfg. No. 1691929 1691930	1	1709998	2	WHEEL & TIRE ASSY, 16 x6.50-8, 4 Ply (1691929)
		1709999	2	WHEEL & TIRE ASSY, 16 x6.50-8, 4 Ply (1691930)
	2	1700842	2	TIRE, 16 x 6.50-8, 4 Ply
	3	1705851	2	RIM ASSY. (Incl. Ref. No. 5) (1691929)
		1705852	2	RIM ASSY. (Incl. Ref. No. 5) (1691930)
	4	172353	2	VALVE STEM & CAP
	5	170836	4	BEARING, Cup

Mfg. No. 1691409, 1691410

Rear Wheel & Tire Group

---

	Ref. No.	Part No.	Qty.	Description
	1	1700684	2	WHEEL & TIRE ASSY., R.H. 26 x 12.00-12 (1691410) Ag
		1700685	2	WHEEL & TIRE ASSY., L.H., 26-12.00-12 (1691410) Ag
		1709962	2	WHEEL & TIRE ASSY. (1691409) Turf
	2	1701344	2	WHEEL
	3	172353	2	VALVE STEM & CAP
	4	1701345	2	TIRE, Tubeless, Ag., 16-12.00-12 (1691410)
		1701346	2	TIRE, Tubeless, Turf, 26 x 12.00-12 (1691409)
	5	1701389	2	TUBE, 26 x 12 x 12

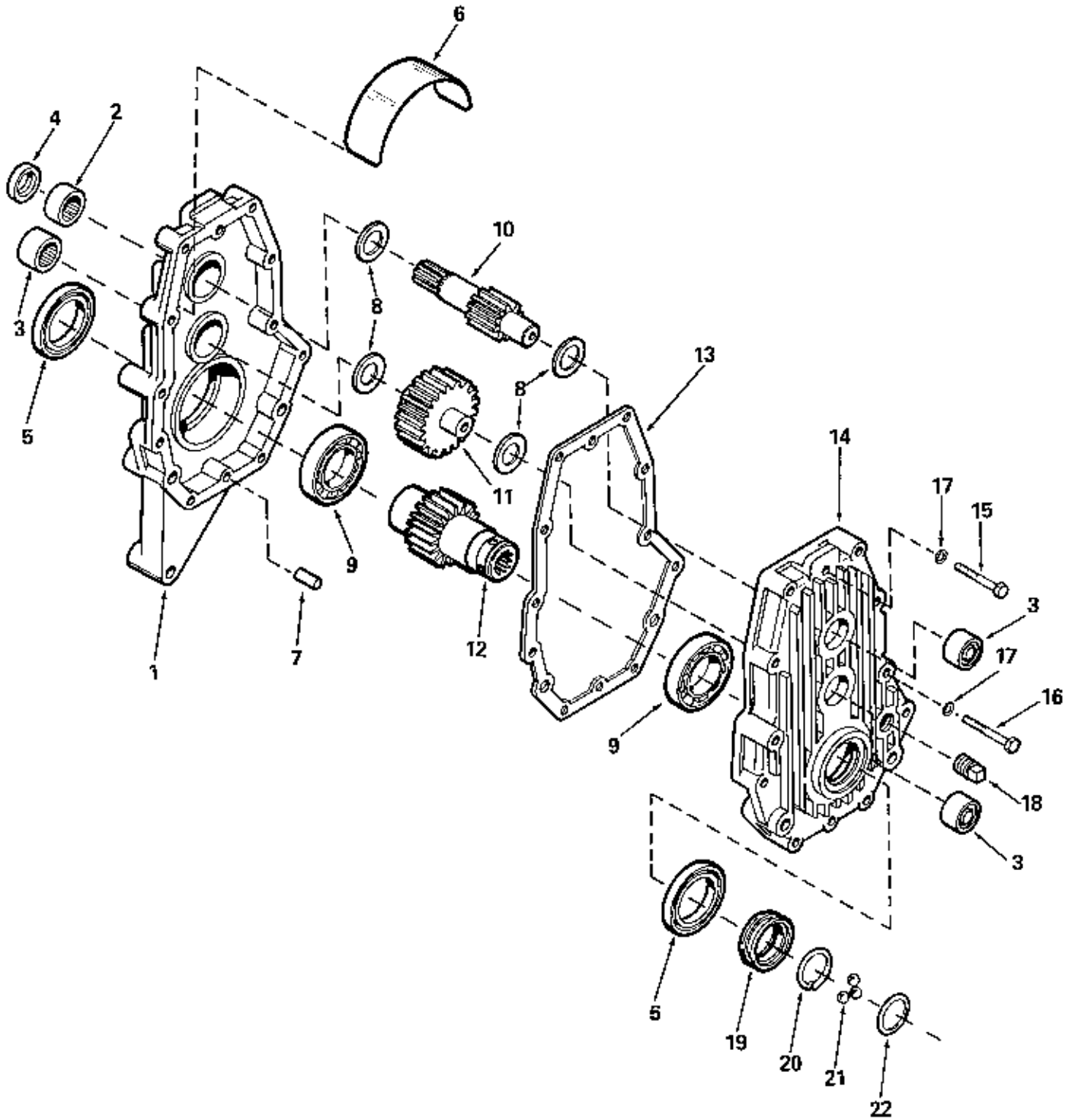

## Peerless Gearbox Model 2800-003

Ref. No.	Part No.	Qty.	Description
1	770074	1	CASE ASSY. (Incl. Ref. Nos. 2 & 3)
2	780074	1	BEARING, Cartridge
3	780049	3	BEARING, Cartridge
4	788031	1	SEAL, Oil
5	788060	2	SEAL, Oil
6	786099	1	BAFFLE
7	786026	2	PIN, Dowel
8	780128	4	WASHER, Thrust
9	780125	2	BEARING, Ball
10	776215A	1	PINION, Input
11	778164	1	GEAR, Idler
12	776216	1	SHAFT, Output
13	788059	1	GASKET
14	772088	1	COVER ASSY. (Incl. Ref. No. 3)
15	650692	8	SCREW, Hex Hd., 5/16-18 x 1-3/4
16	792104	2	SCREW, Hex Hd., 5/16-18 x 2
17	792029	10	LOCKWASHER, 5/16
18	792019	1	PLUG, Magnetic Drain
19	786100	1	COLLAR
20	792107	1	RING, Retaining
21	792105	3	BALL, Steel, 3/8
22	792106	1	RING, Retaining

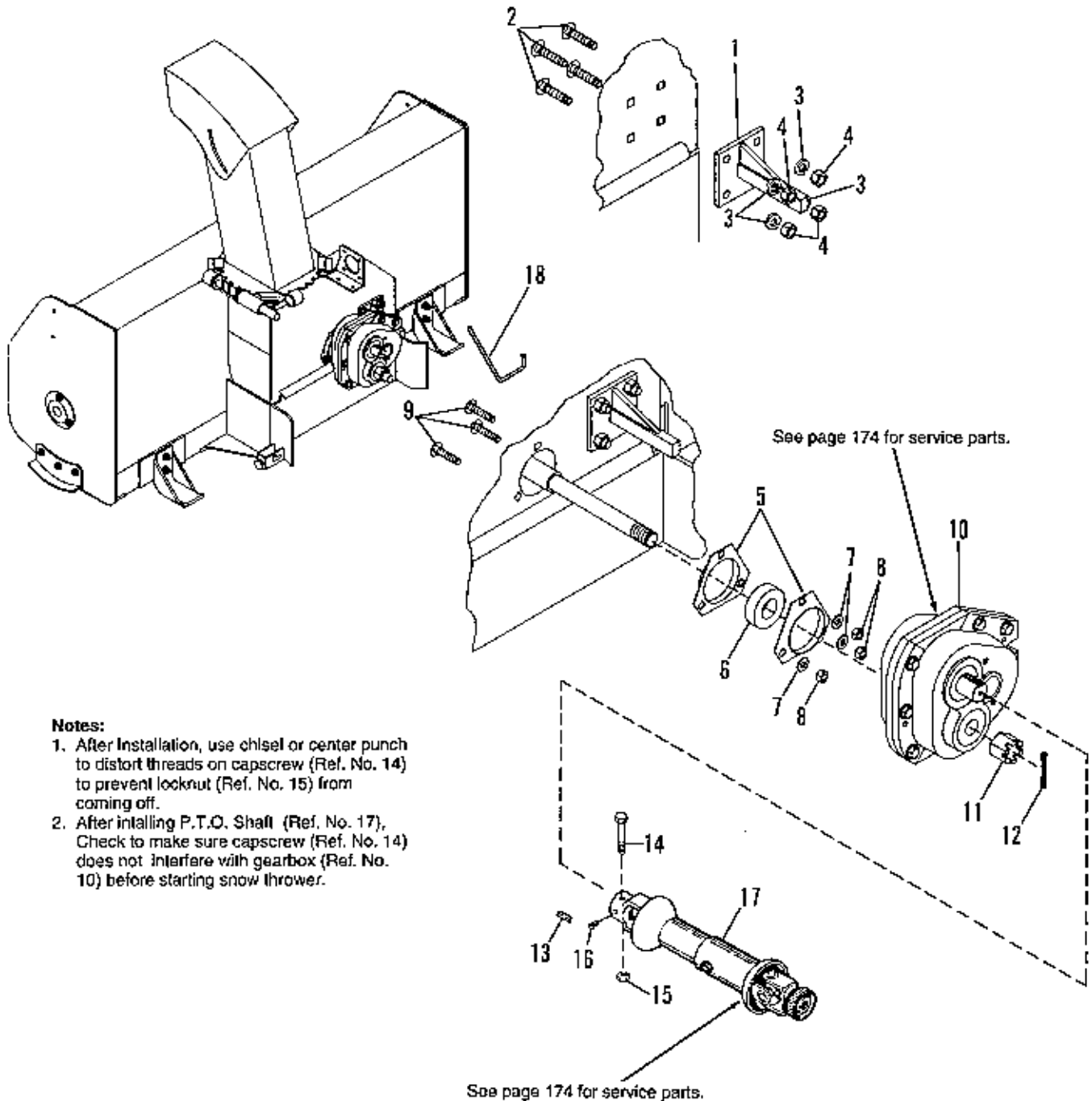
**Notes:**

1. After installation, use chisel or center punch to distort threads on capscrew (Ref. No. 14) to prevent locknut (Ref. No. 15) from coming off.
2. After installing P.T.O. Shaft (Ref. No. 17), Check to make sure capscrew (Ref. No. 14) does not interfere with gearbox (Ref. No. 10) before starting snow thrower.

NOTE: Use standard hardware torque spec. chart unless otherwise noted.

## 47" Snowthrower - Gearbox Mounting

Ref. No.	Part No.	Qty.	Description
1	1709620	1	BRACKET, Torque
2	1709621	4	CARRIAGE BOLT, 3/8-16 x 1
3	1916965	4	LOCKWASHER, 3/8
4	1916950	4	NUT, Hex, 3/8-16
5	1709623	2	FLANGE, Bearing 3-hole
6	1709624	1	BEARING, Discard locking collar
7	1917356	3	LOCKWASHER, 5/16 regular
8	1917372	3	NUT, Hex, 5/16-18
9	1931332	3	CARRIAGE BOLT, 5/16-18 x 5/8
10	1709625	1	GEARBOX ASSEMBLY (see pg. "B" for service parts)
11	1709639	1	NUT, Slotted Hex, 3/4 -16, L.H.
12	1918456	1	PIN, Colter, 5/32 x 1-3/4
13	154096	1	KEY, 1/4 x 1/4 x 29/32
14	1960506	1	CAPSCREW, Hex Hd., 1/4-20 x 1-7/8
15	1923358	1	NUT, Centerlock, 1/4-20
16	1677029	1	SCREW, Set, 5/16 -18 x 3/8
17	1675387	1	DRIVESHAFT, PTO (See pg. "B" for service parts)
18	1709640	1	BRACKET, Wire

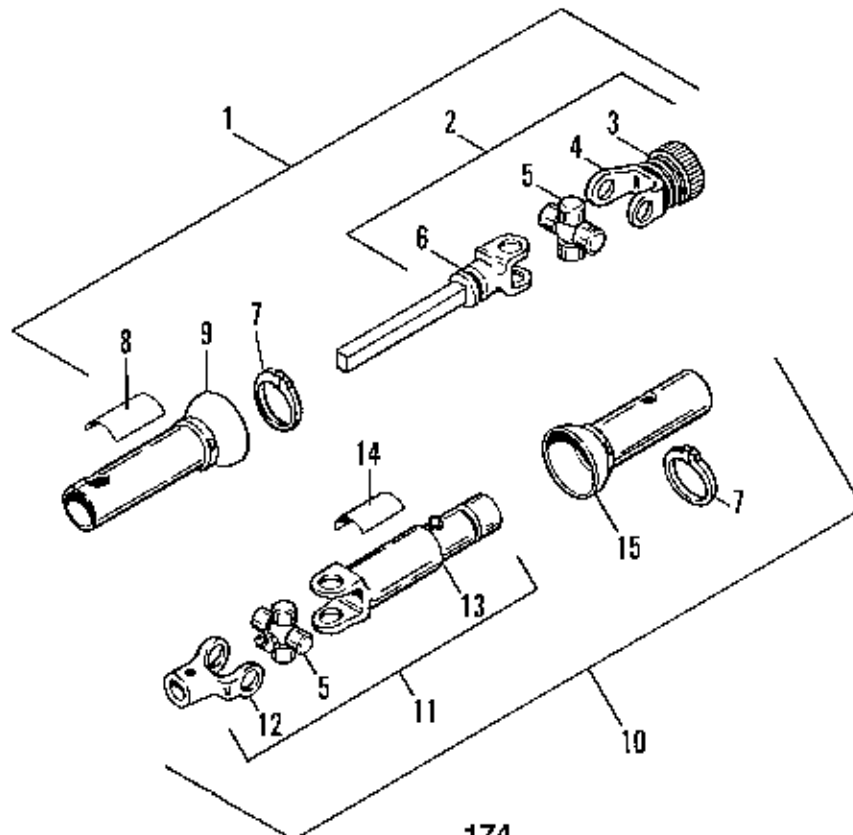
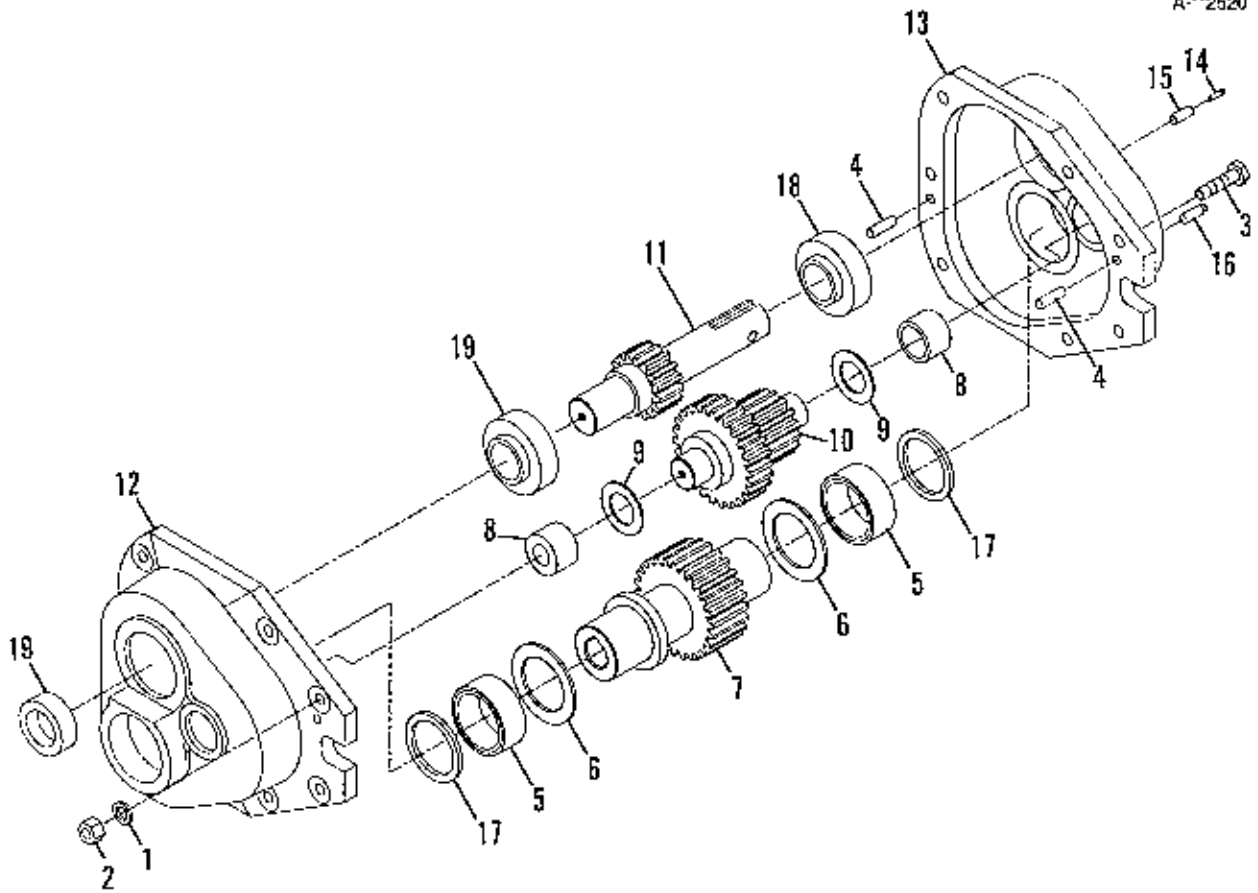

NOTE: Use standard hardware torque spec. chart unless otherwise noted.



## 47" Snowthrower - Gearbox

Ref. No.	Part No.	Qty.	Description
1	1917356	7	LOCKWASHER, 5/16 regular
2	1917372	7	NUT, Hex, 5/16
3	1921977	7	CAPSCREW, Hex Hd., 5/16 18 x 1-1/4
4	917554	2	PIN, Dowel, 1/4 dia x 1/2 lg.
5	1709626	2	BEARING, 1-1/2 x 1-7/8 x 3/4
6	1709627	2	BEARING, Thrust race .090 thick
7	1709628	1	GEAR, Output
8	1709629	2	BEARING, 7/8 x BG-1/8 x 3/4
9	1709630	2	BEARING, Thrust race .060 thick
10	1709631	1	GEAR, Idler
11	1709632	1	GEAR, Input
12	1709633	1	GEARBOX, Snowblower-front
13	1709634	1	GEARBOX, Snowblower-rear
14	1709635	1	VENT, Relief
15	901825	1	BUSHING, 1/4-male, 1/8-female
16	901652	1	PLUG, Pipe, sq. hd.1/4 NPT
17	1709636	2	SEAL, Oil
18	1709637	1	BEARING, Ball, 1.00 bore w/o collar
19	1709638	1	BEARING, Ball, 1.00 bore w/collar

Note: Use S.A.E. 30 weight motor oil

## 47" Snowthrower - Driveshaft

Ref. No.	Part No.	Qty.	Description
1	1709346	1	JOINT & SHAFT ASSY., w/guard (Incl Ref. Nos. 2-9; Qty. 1 ea. of Ref. nos. 5 & 7)
2	1709347	1	JOINT & SHAFT ASSY. (Incl. Ref. Nos. 3-6)
3	1685480	1	SPRING-LOK REPAIR KIT
4	1709350	1	SPRING-LOK YOKE ASSY.
5	1679003	1	CROSS & BEARING KIT
6	1709351	1	YOKE & SHAFT ASSY.
7	1709352	2	REPAIR KIT, Nylon
8	1709353	1	DECAL, Warning
9	1709354	1	GUARD, Outer
10	1709348	1	JOINT & TUBE ASSY., w/guard (Incl. Ref. nos. 5-Qty. 1; 7-Qty. 1; & 11-15)
11	1709349	1	JOINT & TUBE ASSY. (Incl. Ref. Nos. 5-Qty 1; & 12-14)
12	1709358	1	YOKE
13	1709357	1	YOKE TUBE & SLIP SLEEVE ASSY.
14	1709356	1	DECAL, Warning
15	1709355	1	GUARD, Inner

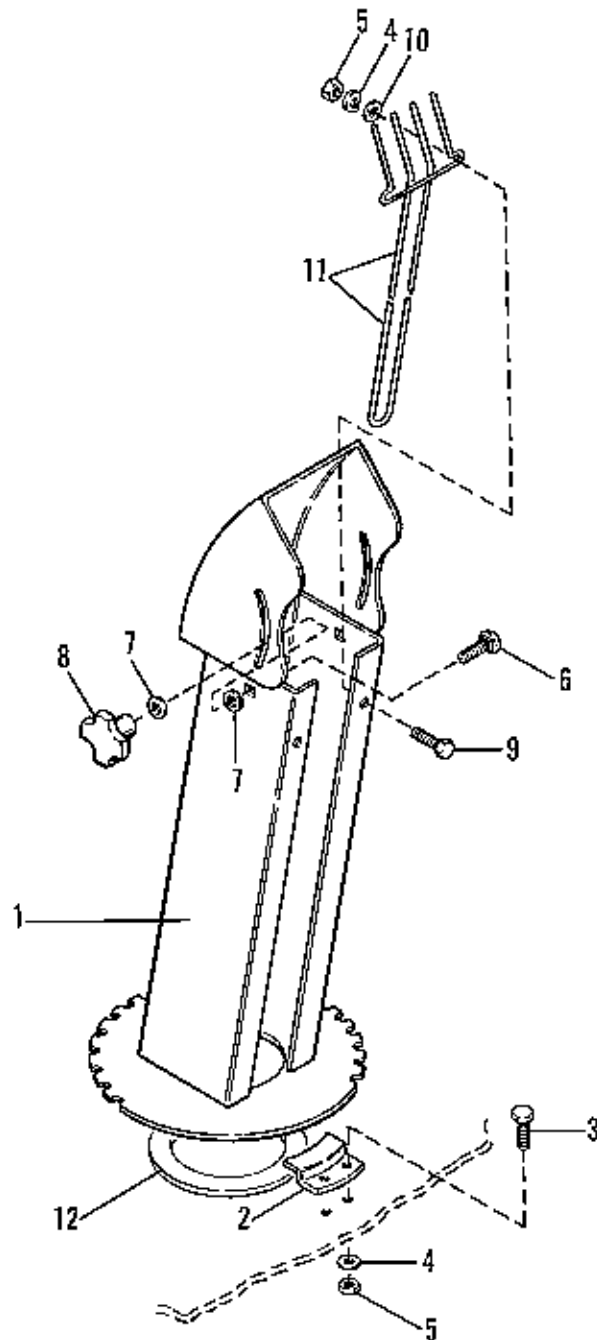

NOTE: Use standard hardware torque spec. chart unless otherwise noted.

47" Snowthrower - Chute Assembly

---

Ref. No.	Part No.	Qty.	Description
1	1709641	1	CHUTE, 47" Snowblower
2	1709642	3	RETAINER, Chute
3	1921958	6	CAPSCREW, Hex Hd., 1/4-20 x 1/2
4	1916964	8	LOCKWASHER, 1/4 regular
5	1916622	8	NUT, Hex, 1/4-20
6	1931333	2	CARRIAGE BOLT, 5/16-18 x 3/4
7	1924874	4	WASHER, Flat, 7/8 OD x 11/32 ID x 1/16
8	1709643	2	KNOB, Hand
9	1921960	2	CAPSCREW, Hex Hd., 1/4-20 x 1
10	1921319	2	WASHER, Flat, 1/4 SAE
11	1709644	1	GUARD, Chute
12	1709645	1	GASKET, Chute

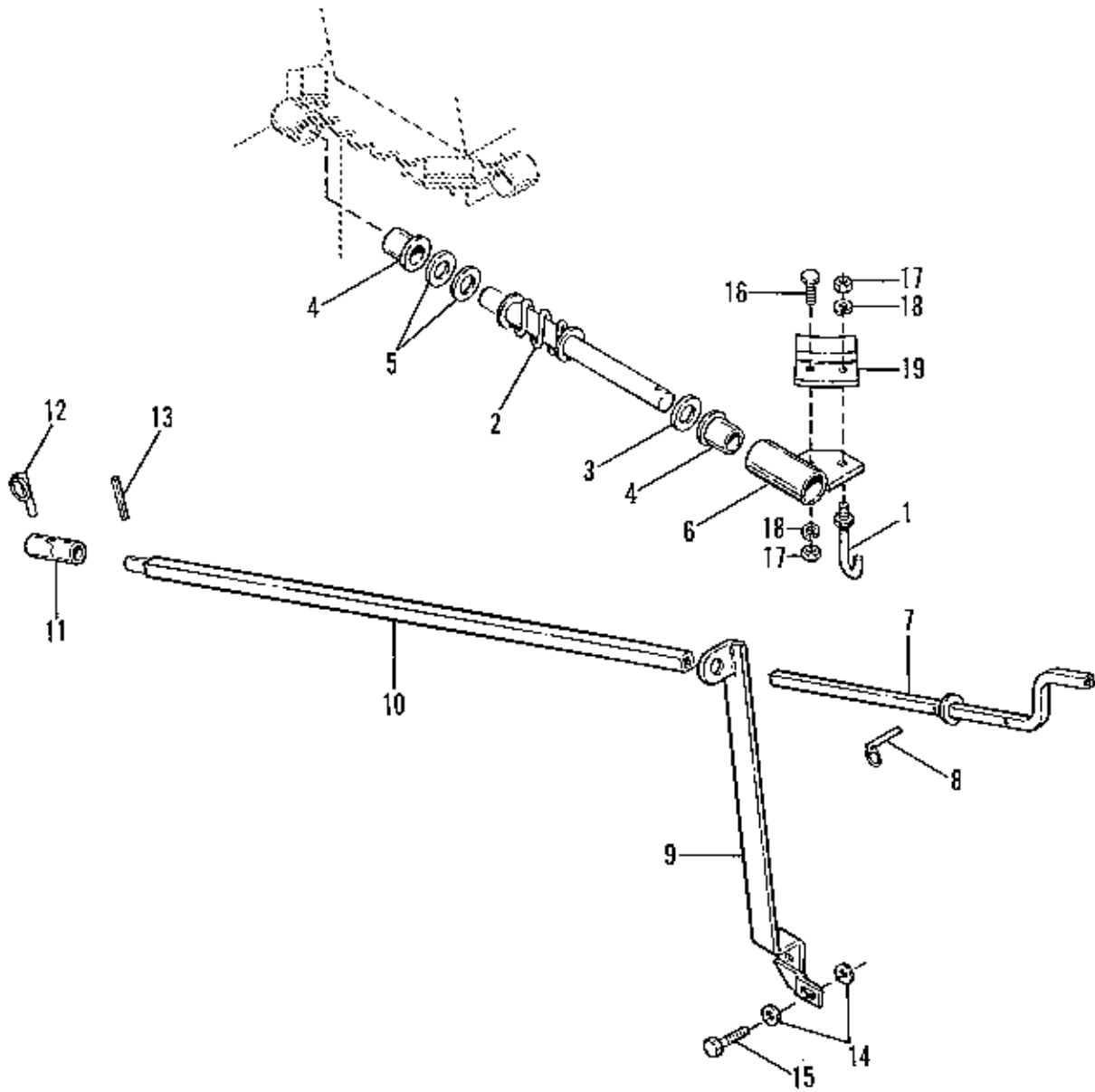

NOTE: Use standard hardware torque spec. chart unless otherwise noted.

## 47" Snowthrower - Handcrank Assembly

Ref. No.	Part No.	Qty.	Description
1	1709646	1	HOOK
2	1709647	1	WIRE, Coil Assembly
3	1960010	1	WASHER, 25/32 x 1-3/8 x .075
4	1709648	2	BUSHING, Turn collar
5	1710650	2	WASHER, 3/4 flat
6	1709649	1	BRACKET, Wire coil support
7	1709650	1	HANDLE, Crank weldment
8	1709651	1	PIN, Detent ring 3/16 x1
9	1709652	1	BRACKET, Handcrank pivot
10	1709653	1	TUBE, Crank weldment
11	1709654	1	JOINT, Universal, w/holes
12	1709655	1	PIN, Detent ring, 5/16 x 1-1/8
13	915523	1	PIN, Roll, 5/16 x 1-1/2
14	1924940	2	WASHER, 13/32 x 7/8 x 5/64
15	1921969	1	CAPSCREW, Hex Hd., 3/8-16 x 1-1/2
16	1921960	1	CAPSCREW, Hex Hd., 1/4-20 x 1
17	1916622	2	NUT, Hex, 1/4-20
18	1916964	2	LOCKWASHER, 1/4
19	1709642	1	RETAINER, Chute

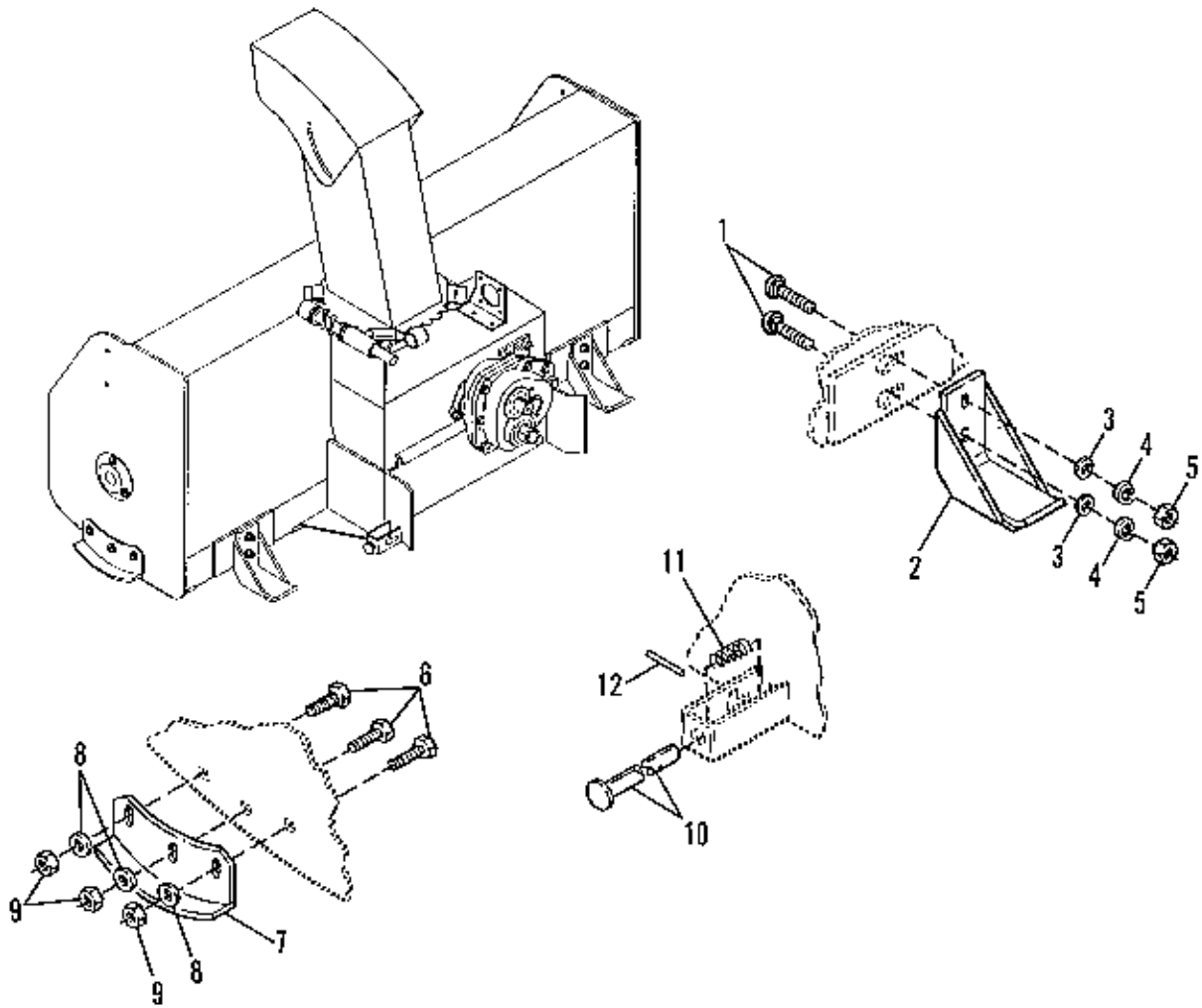

NOTE: Use standard hardware torque spec. chart unless otherwise noted.

47" Snowthrower - Rear Skid Shoe Assembly

---

Ref. No.	Part No.	Qty.	Description
1	1931320	4	CARRIAGE BOLT, 5/16-18 x 1-1/4
2	1709656	2	SHOE, Skid Snowblower
3	1709656	4	WASHER, Flat 5/16 SAE
4	1917356	4	LOCKWASHER, 5/16 regular
5	1917372	4	NUT, Hex, 5/16-18
6	1921332	6	SCREW, Hex Hd. 5/16-18x 3/4
7	1709658	2	SHOE, Skid Snowblower
8	1709657	6	WASHER, Flat 5/16 SAE
9	1923362	6	NUT, Hex Lock 5/16-18
10	1709659	2	PIN, Shot
11	1709660	2	SPRING, Shot pin
12	916171	2	PIN, Roll, 1/4 dia. x 1-1/2 l
13	1709661	2	WASHER, Shot pin (not illustrated)

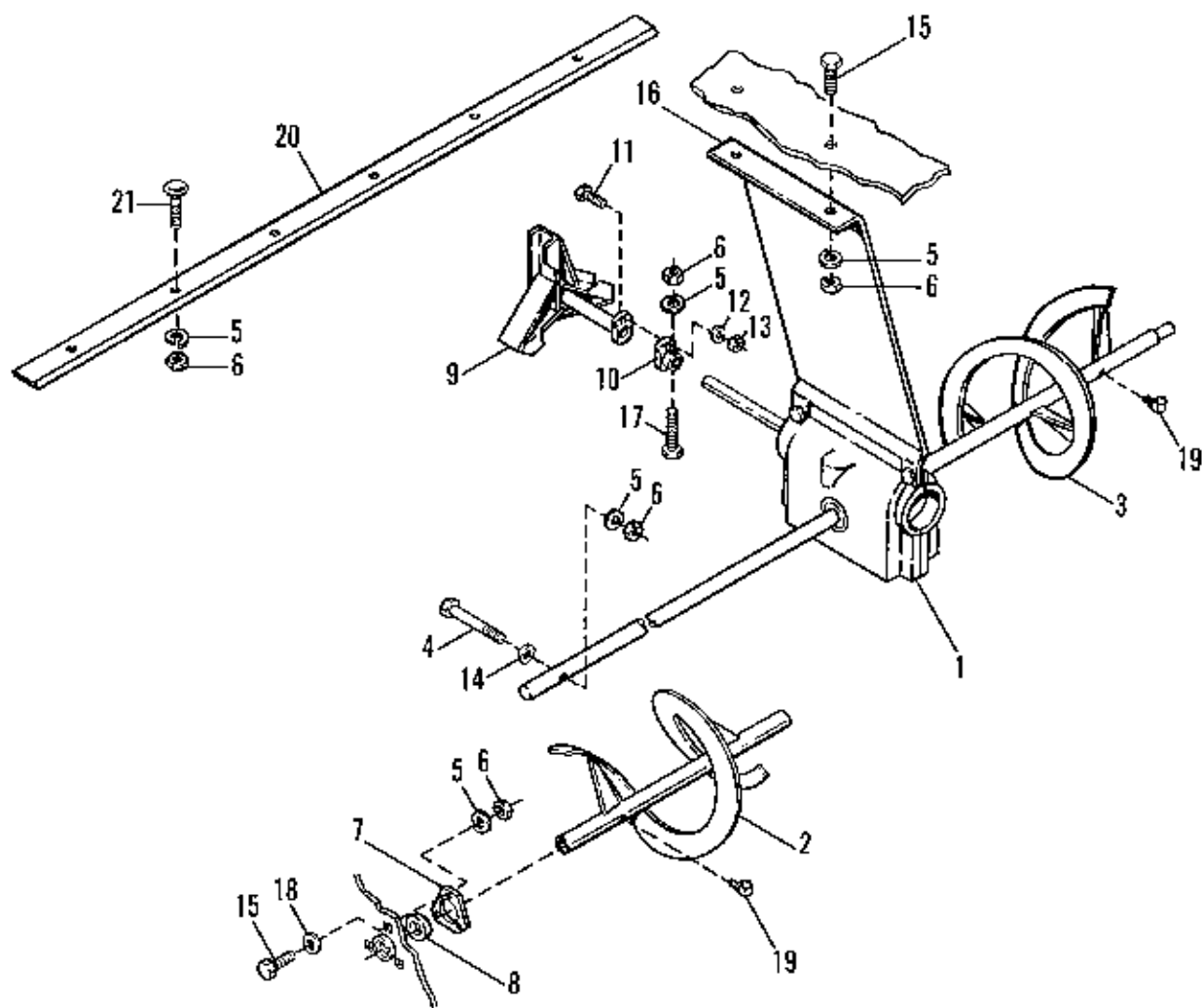

NOTE: Use standard hardware torque spec. chart unless otherwise noted.



## 47" Snowthrower - Auger Assembly

Ref. No.	Part No.	Qty.	Description
1	1709662	1	ASSEMBLY, Gearbox and Shaft (See pg. 184 for Service Parts)
2	1709678	1	AUGER, L. H.
3	1709679	1	AUGER, R. H.
4	1921160	2	CAPSCREW, Hex Hd., 5/16-18 x 2-1/4
5	1917356	17	LOCKWASHER, 5/16 regular
6	1917372	17	NUT, Hex, 5/16-18
7	1709623	2	FLANGE, Bearing, 3-hole
8	1709680	2	BEARING, 1" ID
9	1709681	1	BLADE, Blower
10	1709682	1	COLLAR, Shear
11	1921960	1	CAPSCREW, Hex Hd., 1/4-20 x 1
12	1916964	1	LOCKWASHER, 1/4 regular
13	1916622	1	NUT, Hex, 1/4-20
14	1918265	2	WASHER, Flat, 5/16 SAE
15	1925205	2	CAPSCREW, Hex Hd., 5/16-18 x 5/8
16	1709683	1	BRACKET, Support auger
17	1922127	1	CAPSCREW, Hex Hd., 5/16-18
18	1918264	6	WASHER, Flat, 1/4" SAE
19	912808	2	FITTING, Grease, 1/4-28 thread
20	1709684	1	EDGE, Cutting
21	1931335	6	CARRIAGE BOLT, 5/16-18 x 1

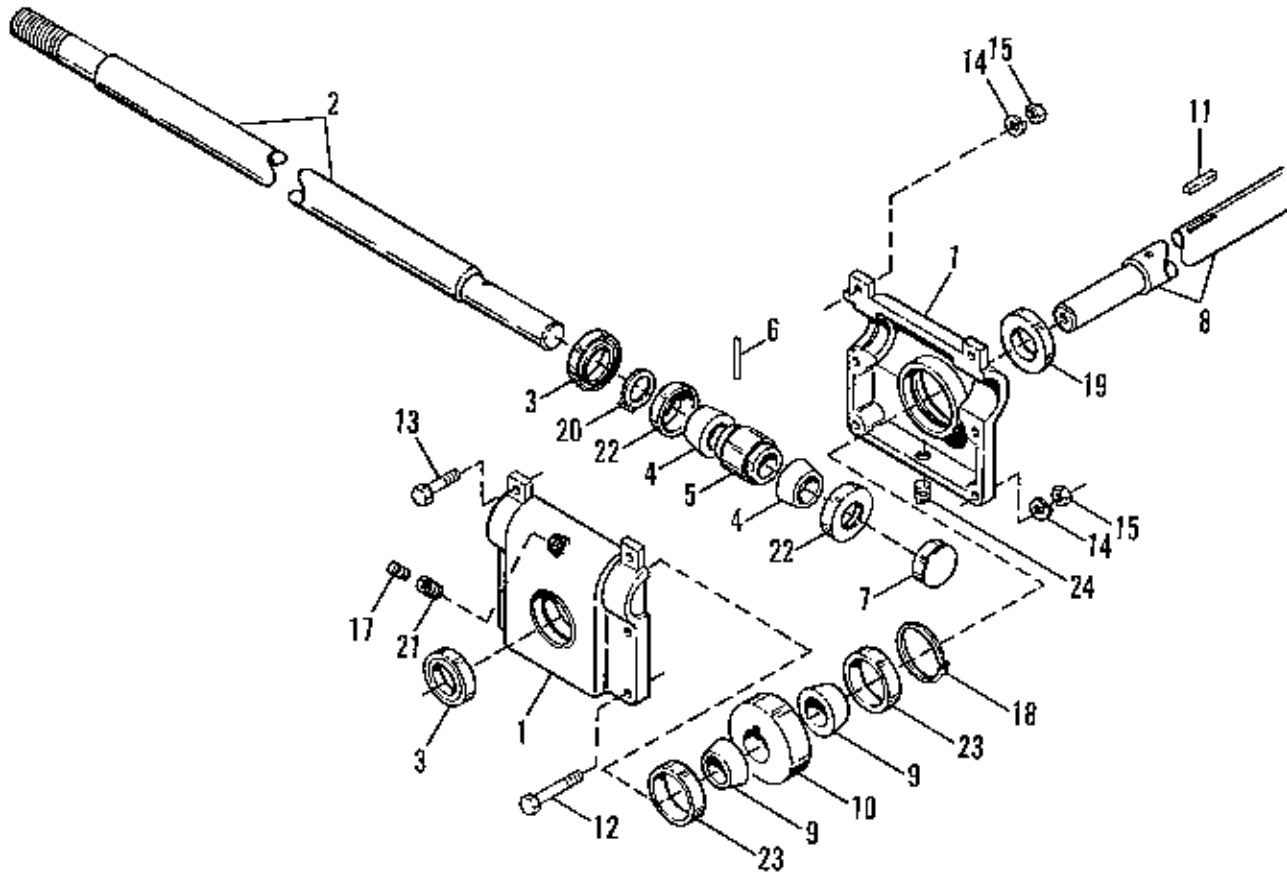

NOTE: Use standard hardware torque spec. chart unless otherwise noted.

## 47" Snowthrower - Gearbox and Shaft Sub-Assembly

Ref. No.	Part No.	Qty.	Description
1	1709663	1	CASE, Gearbox (2-halves)
2	1709664	1	SHAFT, Input
3	1709665	2	SEAL, Oil
4	1709666	2	BEARING, Roller
5	1709667	1	WORM
6	917557	1	PIN, Dowel, 1/4 x 1-1/8
7	1709668	1	PLUG, 2" Dia. x 11/32
8	1709669	1	SHAFT, Output
9	1709670	2	BEARING, Roller
10	1709671	1	GEAR, Worm
11	928712	1	KEY, 1/4 x 1/4 x 5/8
12	1921719	4	CAPSCREW, Hex Hd., 5/16-18 x 2-1/2
13	1921977	2	CAPSCREW, Hex Hd. 5/16-18 x 1-1/4
14	1917356	6	LOCKWASHER, 5/16 Regular
15	1917372	6	NUT, Hex, 5/16-18
16	901652	1	PLUG, Pipe, Sq. Solid Hd. 1/4 NPT
17	1709677	1	BRACKET, Support
18	1709672	1	RING, Retaining
19	1709673	1	SEAL, Oil, 1.0 ID x 2.0 OD
20	1709674	1	RING, Retaining
21	901825	1	BUSHING, 1/4 male x 1/8 female
22	1709675	2	RACE, Bearing
23	1709676	2	RACE, Bearing, 1-31/32 OD x 3/8 W
24	1709635	1	VENT, Relief

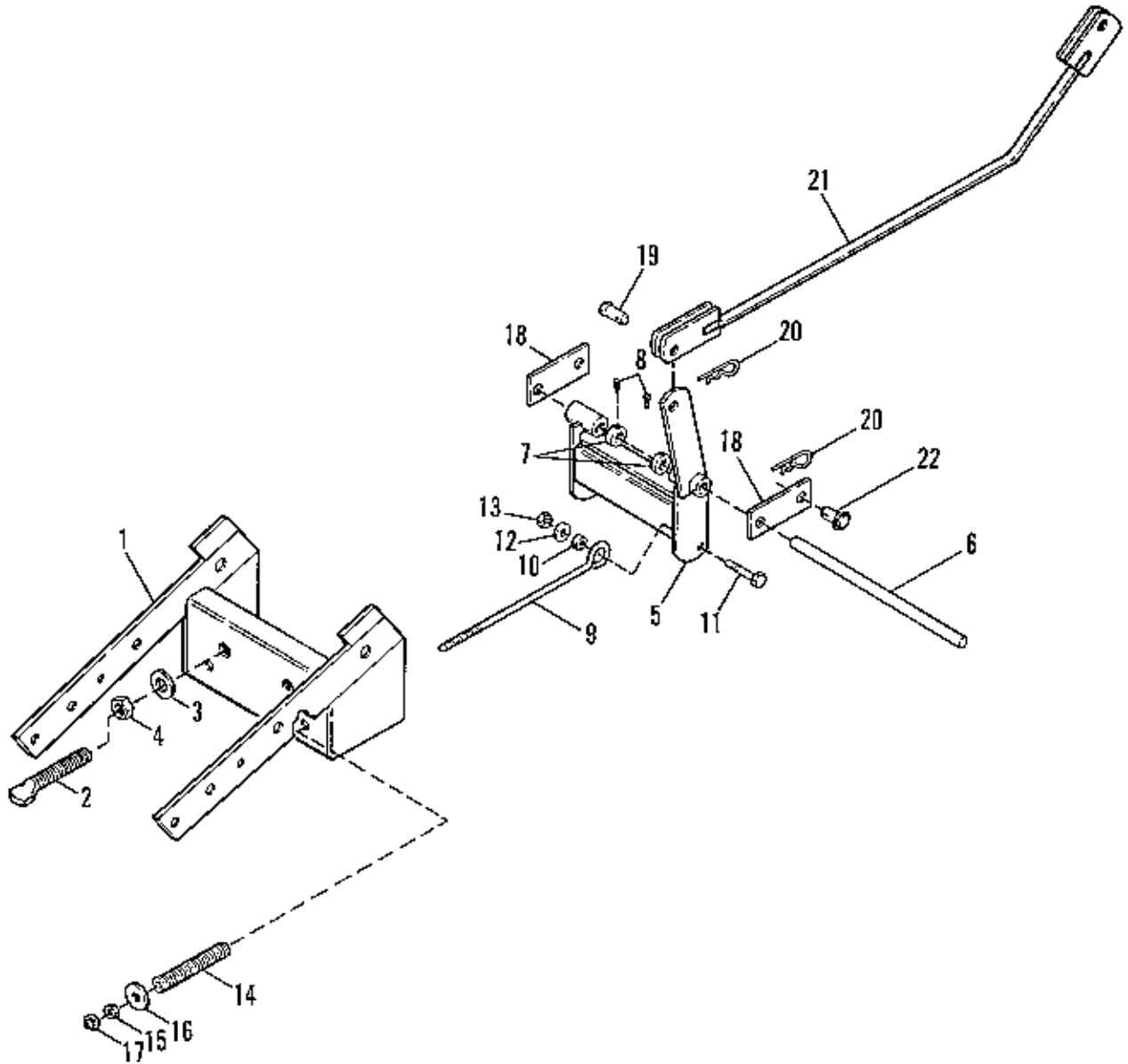

NOTE: Use standard hardware torque spec. chart unless otherwise noted.

## 47" Snowthrower - Hitch &amp; Lift Group

Ref. No.	Part No.	Qty.	Description
1	1703635	1	HITCH ASSY., Blower
2	1676959	2	STUD
3	1919332	2	LOCKWASHER, 3/4 Std.
4	1913160	2	NUT, Hex, 3/4-10
5	1675502	1	HITCH ASSY.
6	1708999	1	SHAFT, Inner
7	8031007	2	SET COLLAR
8	1928721	2	SET SCREW, Sq. Hd. 5/16-18 x 1/2
9	1675523	2	EYEBOLT
10	175647	2	SPACER
11	1922664	2	CAPSCREW, Hex Hd., 5/8-11 x 2
12	933757	2	WASHER, Plain, 41/64 x 1-3/4
13	1923353	2	NUT, Hex, Centerlock, 5/8-11
14	1675524	2	SPRING, Compression
15	1916950	2	NUT, Hex, 3/8-16
16	1960071	2	WASHER, 3/8 x 1-3/4 x 1/4
17	1917421	2	NUT, Hex, Jam, 3/8-16
18	1675525	2	LINK
19	1960038	2	PIN, Clevis
20	1960033	4	CLIP, Hair Pin, 1/8 x 2-9/16
21	1675390	1	LIFT ROD ASSY.
22	1703683	2	PIN ASSY.

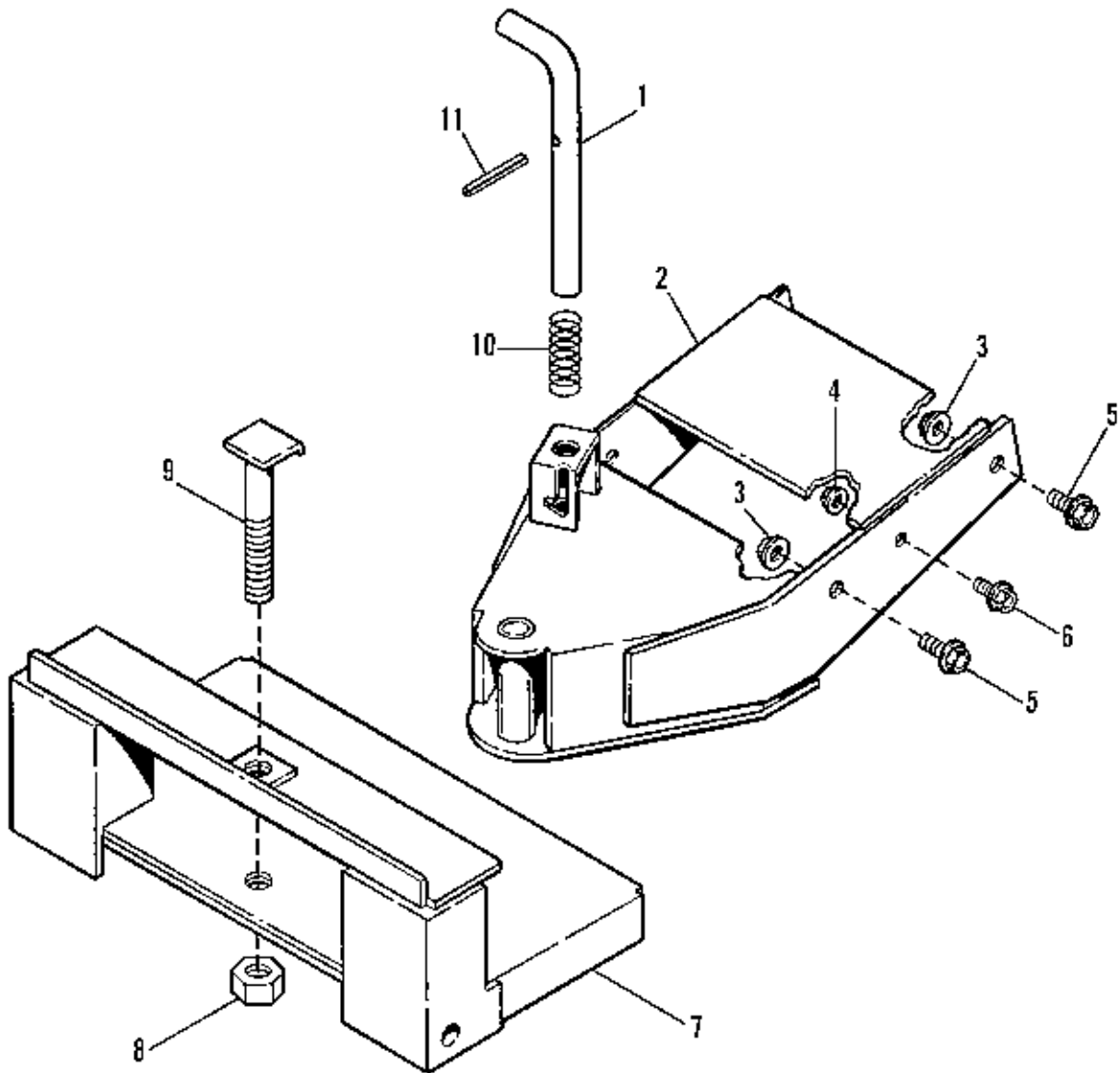

NOTE: Use standard hardware torque spec. chart unless otherwise noted.

47" Snowthrower - Hitch Assembly

---

Ref. No.	Part No.	Qty.	Description
1	1709694	1	PIN, Lock
2	1709691	1	FRAME-A
3	1935041	4	NUT, Hex Flange Whizlock, 7/16-14
4	1928352	2	NUT, Hex Flange Whizlock, 5/16-16
5	1960043	4	CAPSCREW, Hex Whizlock, 7/16-14 x 1
6	1934654	2	CAPSCREW, Hex Whizlock, 3/8-16 x 1
7	1709692	1	PLATE, Pivot
8	1913160	1	NUT, Hex, 3/4-10
9	1709693	1	STUD
10	1709695	1	SPRING
11	918112	1	PIN, Spring 1/4 x 2-3/4

**CAUTION** WHEN OPERATING WITH SNOWTHROWER, REAR WHEEL WEIGHTS ARE REQUIRED.

**DANGER**



TO AVOID SERIOUS INJURY: KEEP HANDS OUT OF THIS DISCHARGE CHUTE WHILE ENGINE IS RUNNING

**WARNING**

FAILURE TO FOLLOW SAFE OPERATING PROCEDURES MAY RESULT IN INJURY.

1. FOR SAFE OPERATION FOLLOW ALL OPERATING INSTRUCTIONS AND SAFETY PRECAUTIONS IN OPERATOR'S MANUAL.
2. KEEP HANDS, FEET AND CLOTHING AWAY FROM POWER DRIVEN PARTS.
3. STOP ENGINE BEFORE LEAVING OPERATOR POSITION.
4. WAIT FOR ALL MOVEMENT TO STOP BEFORE SWAPPING TO ADJUST, LUBRICATE, CLEAN OR UNBLOCK THE MACHINE.
5. KEEP THE AREA OF OPERATION CLEAR OF ALL PERSONS, ESPECIALLY SMALL CHILDREN AND PETS.
6. KEEP ALL GUARDS AND SHIELDS IN PLACE.

**DANGER**



AVOID INJURY FROM ROTATING AUGER. KEEP HANDS, FEET AND CLOTHING AWAY.

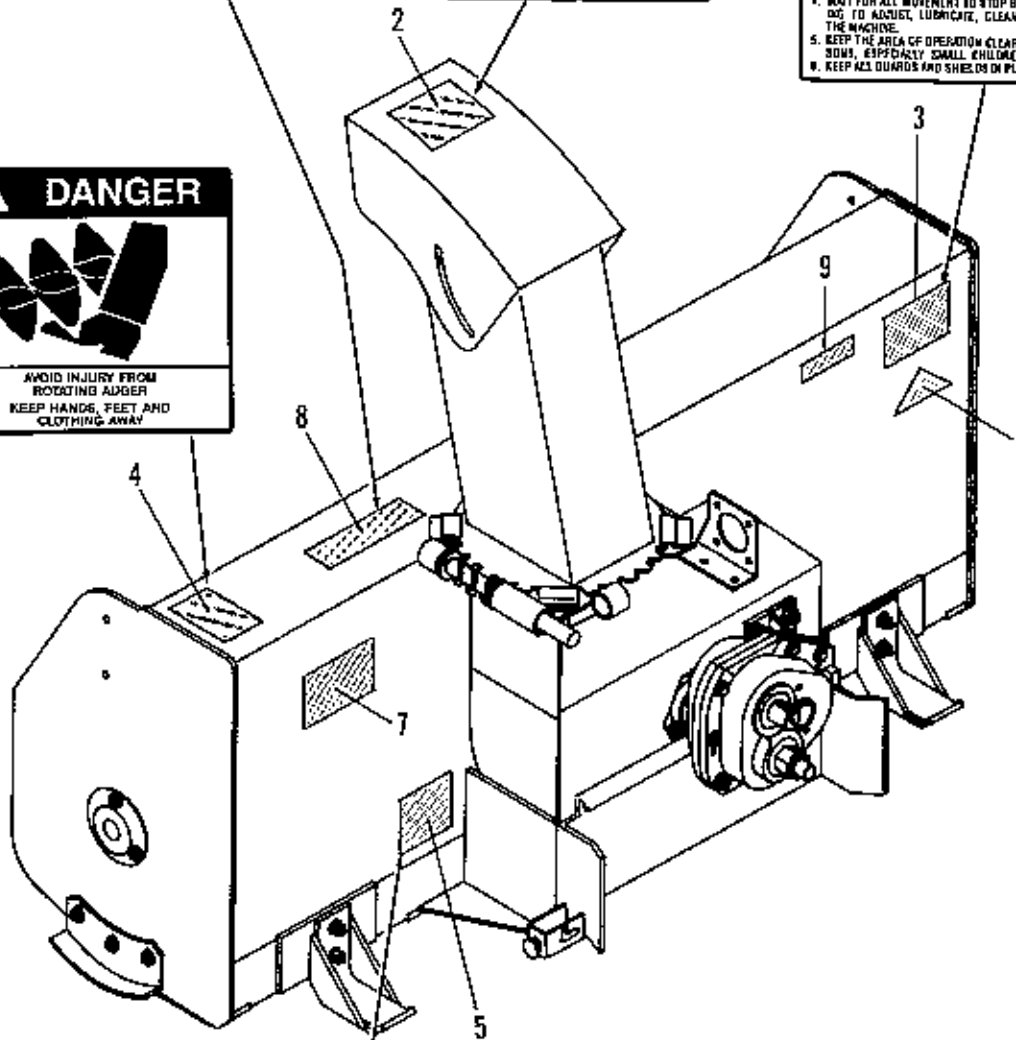

**CAUTION!**

ENSURE PINS SNAP SECURELY INTO THE LOCKED POSITION PRIOR TO OPERATION



**DANGER**



ROTATING DRIVELINE CONTACT CAN CAUSE DEATH. KEEP PEOPLE AND CLOTHING WELL CLEAR.

DO NOT OPERATE WITHOUT:



- ALL DRIVELINE, TRACTOR AND EQUIPMENT SHIELDS IN PLACE.
- DRIVELINES SECURELY ATTACHED AT BOTH ENDS.
- DRIVELINE SHIELDS THAT TURN FREELY ON DRIVELINE.



<b>Ref. No.</b>	<b>Part No.</b>	<b>Qty.</b>	<b>Description</b>
1		1	DECAL, OPEI, (not serviced)
2	1709685	1	DECAL, Danger, Blower Chute
3	1709686	1	DECAL, Danger, Operating Procedures
4	1709687	1	DECAL, Danger, Auger Blade
5	1709688	2	DECAL, Danger, Shot Pins
6	1709689	1	DECAL, Danger, Rotating Driveline
7	1709690	1	DECAL, Important, Shear Bolt
8	1704774	1	DECAL, Caution, Rear Wheel Weights
9		1	I.D. PLATE, (Not Serviced)



**TORQUE SPECIFICATIONS FOR  
STANDARD MACHINE HARDWARE  
TOLERANCE  $\pm 20\%$**

SIZE	SAE GRADE #2 		SAE GRADE #5 		SAE GRADE #8 	
	<u>In./Lbs.</u> Ft./Lbs.	Nm.	<u>In./Lbs.</u> Ft./Lbs.	Nm.	<u>In./Lbs.</u> Ft./Lbs.	Nm.
8-32	19	2.1	30	3.4	41	4.6
8-36	20	2.3	31	3.5	43	4.9
10-24	27	3.1	43	4.9	60	6.8
10-32	31	3.5	49	5.5	68	7.7
1/4-20	66	7.6	8	10.9	12	16.3
1/4-28	76	8.6	10	13.6	14	19.
5/16-18	11	15.	17	23.1	25	34.
5/16-24	12	16.3	19	25.8	25	34.
3/8-16	20	27.2	30	40.8	45	61.2
3/8-24	23	31.3	35	47.6	50	68.
7/16-14	30	40.8	50	68.	70	95.2
7/16-20	35	47.6	55	74.8	80	108.8
1/2-13	50	68.	75	102.	110	149.6
1/2-20	55	74.8	90	122.4	120	163.2
9/16-12	65	88.4	110	149.6	150	204.
9/16-18	75	102.	120	163.2	170	231.2
5/8-11	90	122.4	150	204.	220	299.2
5/8-18	100	136.	180	244.8	240	326.4
3/4-10	160	217.6	260	353.6	386	525.
3/4-16	180	244.8	300	408.	420	571.2
7/8-9	140	190.4	400	544.	600	816.
7/8-14	155	210.8	440	598.4	660	897.6
1-8	220	299.2	580	788.8	900	1,224.
1-12	240	326.4	640	870.4	1,000	1,360.

**NOTE:**

1. These torque values are to be used for all hardware excluding: locknuts, self-tapping screws, thread forming screws, sheet metal screws and socket head setscrews.
2. Recommended seating torque values for locknuts:
  - a. For prevailing torque locknuts - use 65% of grade 5 torques.
  - b. For flange whizlock nuts (and screws) - use 135% of grade 5 torques.
3. Unless otherwise noted on assembly drawings all torque values must meet this specification.

**BOLT HEAD MARKING**

**S.A.E. GRADE:**

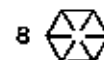
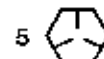
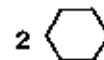

**AGCO ALLIS**  
Outdoor Power  
Equipment

**AGCO Allis Lawn & Garden Equipment**  
500 N. Spring St., P.O. Box 997  
Port Washington, WI USA 53074-0997

TP-1179-02  
PRINTED IN U.S.A.  
©1993  
6/93 - CCI