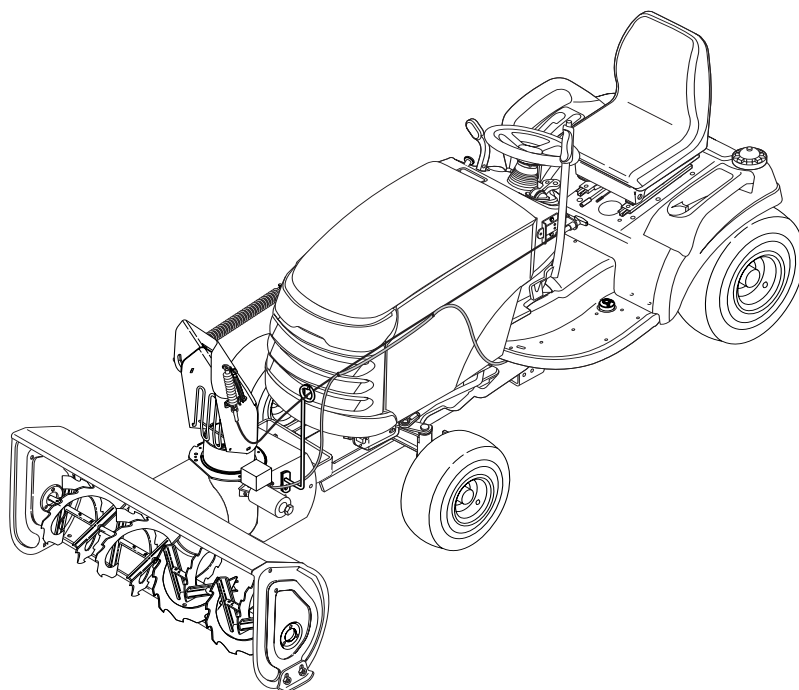




# ATTACHMENT OPERATOR'S MANUAL

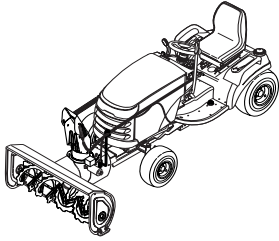


## 42" Two-Stage Snowthrower

### 42" Snowthrower Attachment

Mfg. No.	Description
1694238	42" Two-Stage Snowthrower
1694874	42" Two-Stage Snowthrower
1695099	42" Two-Stage Snowthrower






# Table of Contents

<b>Recommended Accessories .....</b>	<b>1</b>	<b>Troubleshooting, Adjustments &amp; Service</b>	
<b>Safety Rules &amp; Information</b>		Troubleshooting Chart .....	11
Training .....	2	Skid Shoe Adjustment .....	12
Preparation .....	2	Electric Chute Rotator Gear .....	12
Operation .....	2	Auger Shear Pins .....	12
Children .....	3	Impeller Shear Bolt .....	12
Clearing a Clogged Discharge Chute .....	3	Lift Adjustment .....	13
Service, Maintenance and Storage .....	3	Belt Tension Adjustment .....	14
Emissions .....	3	Belt Replacement .....	14
Decals .....	4	<b>Initial Setup &amp; Assembly</b>	
<b>Required Accessories .....</b>	<b>5</b>	Snowthrower Components .....	15
<b>Recommended Accessories .....</b>	<b>5</b>	Install Hitch .....	16
<b>Clean-Out Warning and Procedure .....</b>	<b>5</b>	Assemble Discharge Chute .....	16
<b>Features &amp; Controls</b>		Install Skid Shoes .....	17
Control Functions .....	6	Attach Deflector Control Cable Support .....	17
<b>General Operating Instructions</b>		Install Chute Rotator Switch & Harness .....	17
Checks Before Starting .....	7	Mount Remote Deflector Control .....	18
Engine & Ground Speed Selection .....	7	Mount Lift Assist Bracket (Manual Lift) .....	18
Stopping & Starting .....	7	Install Snowthrower .....	19
Transporting .....	7	<b>Removal &amp; Normal Installation</b>	
Snow Removal Suggestions .....	8	Removal .....	22
Daily Storage .....	8	Normal Installation .....	23
Off-Season Storage .....	8	Lift Variations When Using Attachments .....	24
<b>Maintenance</b>		<b>Hardware Torque Specifications</b>	
Schedule for Normal Care .....	9	Chart .....	25
General Lubrication .....	9	<b>Mounting Remote Deflector Control</b>	
Check Auger Gear Box Oil Level .....	10	Instructions .....	26
Check the Impeller Gear Box Oil Level .....	10	Template .....	27

*NOTE: In these instructions, “left” and “right” are referred to as seen from the operating position.*

# Safety Rules & Information



This machine is capable to amputating hands and feet and throwing objects. Read these safety rules and follow them closely. Failure to obey these rules could result in loss of control of unit, severe personal injury or death to you, or bystanders, or damage to property or equipment. The triangle  in text signifies important cautions or warnings which must be followed.

## TRAINING

1. Read, understand, and follow all instructions on the machine and in the manuals before operating this unit. Be thoroughly familiar with the controls and the proper use of the equipment. Know how to stop the unit and disengage the controls quickly.
2. Never allow children to operate the equipment. Never allow adults to operate the equipment without proper instruction.
3. Keep the area of operation clear of all persons, particularly small children and pets.

## PREPARATION

1. Thoroughly inspect the area where the equipment is to be used and remove all doormats, sleds, boards, wires, and other foreign objects.
2. Disengage all clutches and shift into neutral before starting engine (motor).
3. Do not operate the equipment without wearing adequate winter outer garments. Avoid loose fitting clothing that can get caught in moving parts. Wear footwear that will improve footing on slippery surfaces.
4. Handle fuel with care; it is highly flammable.
  - (a) Use an approved fuel container.
  - (b) Never add fuel to a running engine or hot engine.
  - (c) Fill fuel tank outdoors with extreme care. Never fill fuel tank indoors. Replace fuel cap securely and wipe up spilled fuel.
  - (d) Never fill containers inside a vehicle or on a truck or trailer bed with a plastic liner. Always place containers on the ground, away from your vehicle, before filling.
  - (e) When practical, remove gas-powered equipment from the truck or trailer and refuel it on the ground. If this is not possible, then refuel such on a trailer with a portable container, rather than from a gasoline dispenser nozzle.
  - (f) Keep nozzle in contact with the rim of the fuel tank or container opening at all times, until refueling is complete. Do not use a nozzle lock-open device.
  - (g) Replace gasoline cap securely and wipe up spilled fuel.
  - (h) If fuel is spilled on clothing, change clothing immediately.
5. Adjust the collector housing height to clear gravel or crushed rock surfaces.
6. Never attempt to make any adjustments while the engine (motor) is running (except when specifically recommended by the manufacturer).
7. Let engine (motor) and machine adjust to outdoor temperatures before starting to clear snow.
8. Always wear safety glasses or eye shields during operation or while performing an adjustment or repair to protect eye from foreign objects that may be thrown from the machine.

## OPERATION

1. Do not put hands or feet near or under rotating parts. Keep clear of the discharge opening at all times.
2. Exercise extreme caution when operating on or crossing gravel drives, walks, or roads. Stay alert for hidden hazards or traffic. Do not carry Passengers.
3. After striking a foreign object, stop the engine (motor), remove the wire from the spark plug, disconnect the cord on electric motors, thoroughly inspect the snowthrower for any damage, and repair the damage before restarting and operating the snowthrower.
4. If the unit should start to vibrate abnormally, stop the engine (motor) and check immediately for the cause. Vibration is generally a warning of trouble.
5. Stop the engine (motor) whenever you leave the operating position, before unclogging the collector/impeller housing or discharge guide, and when making any repairs, adjustments, or inspections.
6. When leaving the machine unattended, disengage the power take-off (PTO), lower the attachment, set the parking brake, stop the engine, and remove the key.
7. When cleaning, repairing, or inspecting make certain the collector/impeller and all moving parts have stopped. Disconnect the spark plug wire and keep the wire away from the plug to prevent accidental starting. Do not run the engine indoors except for starting the engine or for transporting the snowthrower in or out of the building. Open the outside doors; exhaust fumes are dangerous.
8. Exercise extreme caution when operating on slopes. Do not attempt to clear steep slopes.
9. Never operate the snowthrower without proper guards plates, or other safety protective devices in place and working.
10. Never direct the discharge toward people or areas where property damage can occur. Keep children and others away.
11. Do not overload the machine capacity by attempting to clear snow at too fast a rate.
12. Never operate the machine at high transport speeds on slippery surfaces. Look behind and use care when operating in reverse.
13. Disengage power to the collector/impeller when snowthrower is transported or not in use.
14. Use only attachments and accessories approved by the manufacturer of the snowthrower (such as wheel weights, counterweights, or cabs).
15. Never operate the snowthrower without good visibility or light. Always be sure of your footing, and keep a firm hold on the handles. Walk, never run.
16. Never touch a hot engine or muffler.
17. Never operate the snowthrower near glass enclosures, automobiles, window wells, drop-offs, and the like without proper adjustment of the discharge angle.
18. Never direct discharge at bystanders or allow anyone in front of the unit.

19. Never leave a running unit unattended. Always disengage the auger and traction controls, stop engine, and remove keys.
20. Do not operate the unit while under the influence of alcohol or drugs.
21. Keep in mind the operator is responsible for accidents occurring to other people or property.
22. Data indicates that operators, age 60 years and above, are involved in a large percentage of power equipment-related injuries. These operators should evaluate their ability to operate the unit safely enough to protect themselves and others from injury.
23. DO NOT wear long scarves or loose clothing that could become entangled in moving parts.
24. Snow can hide obstacles. Make sure to remove all obstacles from the area to be cleared.
7. Always observe safe refueling and fuel handling practices when refueling the unit after transportation or storage.
8. Always follow the engine manual instructions for storage preparations before storing the unit for both short and long term periods.
9. Always follow the engine manual instructions for proper start-up procedures when returning the unit to service.
10. Maintain or replace safety and instruction labels as necessary.
11. Keep nuts and bolts tight and keep equipment in good condition.
12. Never tamper with safety devices. Check their proper operation regularly and make necessary repairs if they are not functioning properly.
13. Components are subject to wear, damage, and deterioration. Frequently check components and replace with manufacturer's recommended parts, when necessary.
14. Check control operation frequently. Adjust and service as required.
15. Use only factory authorized replacement parts when making repairs.
16. Always comply with factory specifications on all settings and adjustments.
17. Only authorized service locations should be utilized for major service and repair requirements.
18. Never attempt to make major repairs on this unit unless you have been properly trained. Improper service procedures can result in hazardous operation, equipment damage and voiding of manufacturer's warranty.
19. Check shear bolts and other bolts at frequent intervals for proper tightness to be sure the equipment is in safe working condition.

## CHILDREN

Tragic accidents can occur if the operator is not alert to the presence of children. Children are often attracted to the unit and the operating activity. Never assume that children will remain where you last saw them.

1. Keep children out of the area and under the watchful care of another responsible adult.
2. Be alert and turn unit off if children enter the area.
3. Never allow children to operate the unit.
4. Use extra care when approaching blind corners, shrubs, trees, or other objects that may obscure vision.

## CLEARING A CLOGGED DISCHARGE CHUTE

Hand contact with the rotating impeller inside the discharge chute is the most common cause of injury associated with snowthrowers. Never use your hand to clean out the discharge chute.

To clear the chute:

1. SHUT OFF THE ENGINE.
2. Wait 10 seconds to be sure the impeller blades have stopped rotating.
3. Always use a clean out tool, not your hands.

## SERVICE, MAINTENANCE, AND STORAGE

1. Check shear bolts and other bolts at frequent intervals for proper tightness to be sure the equipment is in safe working condition.
2. Never store the machine with fuel in the fuel tank inside a building where ignition sources are present such as hot water and space heaters, or clothes dryers. Allow the engine to cool before storing in any enclosure.
3. Always refer to the operator's manual for important details if the snowthrower is to be stored for an extended period.
4. Maintain or replace safety and instruction labels as necessary.
5. Run the machine a few minutes after throwing snow to prevent freeze-up of the collector/impeller.
6. If fuel is spilled, do not attempt to start the engine but move the machine away from the area of spillage and avoid creating any source of ignition until fuel vapors have dissipated.

## EMISSIONS

1. Engine exhaust from this product contains chemicals known, in certain quantities, to cause cancer, birth defects, or other reproductive harm.
2. If available, look for the relevant Emissions Durability Period and Air Index information on the engine emissions label.

# Safety Decals

## SAFETY DECALS

This unit has been designed and manufactured to provide you with the safety and reliability you would expect from an industry leader in outdoor power equipment manufacturing.

Although reading this manual and the safety instructions it contains will provide you with the necessary basic knowledge to operate this equipment safely and effectively, we have placed several safety labels on the unit to remind you of this important information while you are operating your unit.

All DANGER, WARNING, CAUTION and instructional messages on your unit should be carefully read and obeyed. Personal bodily injury can result when these instructions are not followed. The information is for your safety and it is important! The safety decals below are on your unit.

If any of these decals are lost or damaged, replace them at once. See your local dealer for replacements.

These labels are easily applied and will act as a constant visual reminder to you, and others who may use the equipment, to follow the safety instructions necessary for safe, effective operation.



Part No. 1716532  
Auger Danger Decal



Part No. 1722674  
Discharge Chute Danger Decal



Part No. 1716531  
Main Operation Warning Decal



Part No. 1716540  
Rear Wheel Weights Required

### Required Accessories

It is required that tire chains and two rear wheel weights or Quick Tach Weights are used.

**Never operate on slopes greater than 17.6% (10°).**

### Recommended Accessories

A rear-mounted weight box can also be added for additional traction. The maximum weight added to the tractor should not exceed 35 lbs. per wheel, plus 100 additional pounds in the rear weight box.

For operation on slopes greater than 15% (8.5°), Quick Tach Weights, tire chains, and wheel weights are recommended. **Never operate on slopes greater than 17.6% (10°).**

### Required Accessories

A Lift Lever Kit is required for some of the models covered by this manual, and must be installed as part of hitch installation.



### TRACTOR CONTROLS

Before you begin operating the tractor and attachment, make certain you have:

- **Read and understood the instructions in the tractor Operator's Manual.**
- **Become thoroughly familiar with all of the tractor controls and their operation, including how to safely and properly start and stop the unit.**
- **Practice driving in an open area, without the attachment, to become accustomed to the unit.**

### DANGER

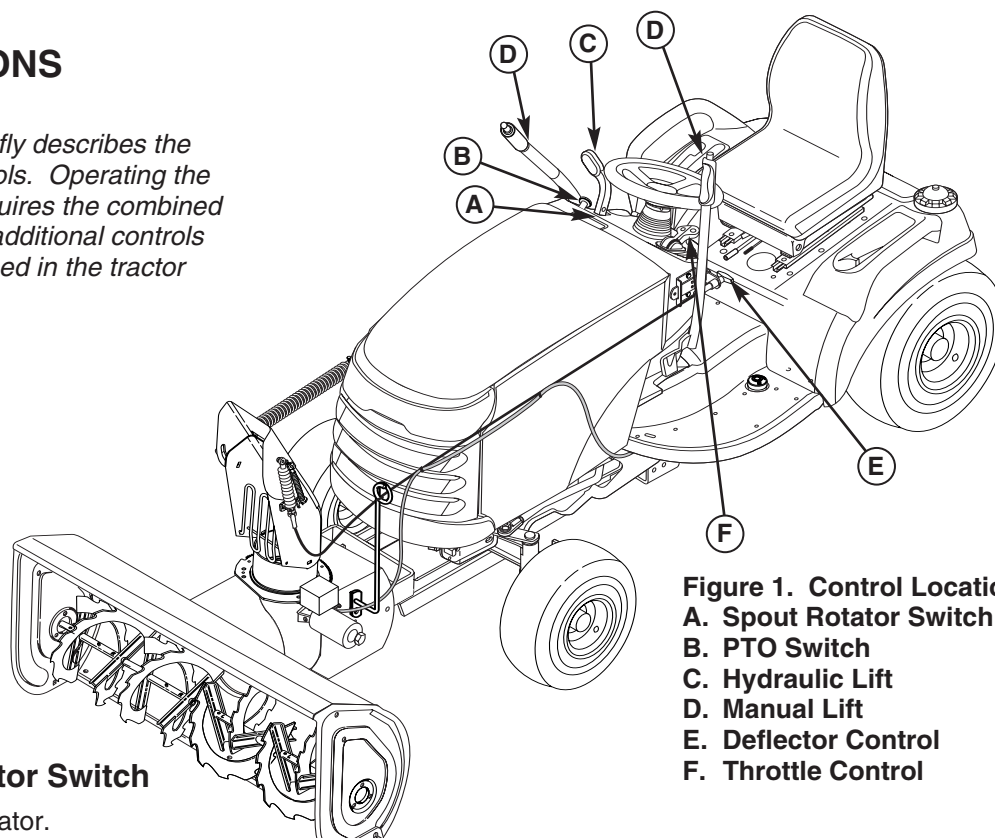
**Do not clean out discharge chute with hands. Contact with moving parts inside chute will cause serious injury. Use a clean out tool. Use the following procedure to remove objects or clear the chute:**

1. Stop the engine. Remove the key
2. Wait 10 seconds to be sure the auger/impeller blades have stopped rotating.
3. Always use a clean-out tool. **DO NOT** use your hands.

## CONTROL FUNCTIONS

The information below briefly describes the function of individual controls. Operating the tractor and attachment requires the combined use of these controls and additional controls whose operation is described in the tractor Operator's Manual.

Please take a moment and familiarize yourself with the name, location, and function of these controls so that you will better understand the safety and operating instructions provided in this manual.



**Figure 1. Control Locations**  
A. Spout Rotator Switch  
B. PTO Switch  
C. Hydraulic Lift  
D. Manual Lift  
E. Deflector Control  
F. Throttle Control

### A. Electric Spout Rotator Switch

Controls the electric spout rotator.

### B. PTO Switch

Engages and disengages the PTO to start and stop the snowthrower.

### C. Hydraulic Attachment Lift Lever

*NOTE: The hydraulic lift will only work with the engine running and the parking brake disengaged.*

The attachment lift lever raises and lowers the attachment. To RAISE the attachment, pull the lever back. To LOWER the attachment, move the lever forward.

### D. Manual Attachment Lift Lever

The attachment lift lever raises and lowers the attachment. To RAISE an attachment, depress the release button on top of the lever and pull back. To LOWER an attachment, depress the release button and move the lever forward. When lowering the attachment, be sure to push the lever fully forward into the locked position.

### E. Deflector Control

The deflector control changes the angle of the snowthrower discharge deflector. Twist the handle to unlock it, and pull/push it to change the angle.

### F. Throttle Control

Always operate at FULL throttle.



## TRACTOR CONTROLS

Before you begin operating the tractor and attachment, make certain you have:

- Read and understood the instructions in the tractor Operator's Manual.
- Become thoroughly familiar with all of the tractor controls and their operation, including how to safely and properly start and stop the unit.
- Practice driving in an open area, without the attachment, to become accustomed to the unit.





# General Operating Instructions

## WARNING

If auger does not start and stop when engaging/disengaging electric clutch, see your authorized dealer. Under no circumstances should you attempt to defeat the safety system.

### Checks Before Starting

**IMPORTANT NOTE:** Refer to Tractor Operator's Manual for important information concerning safely storing your tractor.

1. Refer to the Maintenance & Adjustments sections of this manual and perform any needed service. Also, refer to the tractor Operator's Manual and perform any required service.
2. Remove any objects from the work area which might be caught in, or thrown by, the auger.
3. Before starting the engine, clear the auger of any ice particles which may cause damage to auger.
4. Adjust the deflector and skid shoes to desired height. See Skid Shoe Adjustment and Deflector Adjustment.
5. Make sure all hardware is present and secure.

### Engine & Ground Speed Selection

Always run the engine at full throttle.

Normally, a slow ground speed is best for throwing snow. The deeper or heavier the snow, the slower the recommended ground speed.

### Starting & Stopping

1. Start the tractor engine. Set engine throttle FULL.
2. Lower the snowthrower.
3. Engage the electric clutch switch. Snowthrower auger should rotate. Disengage the electric clutch switch. Snowthrower auger should stop.
4. Adjust the throttle to full speed. Select the proper ground speed.
5. To stop tractor movement, depress the clutch/brake pedal. To stop the snowthrower, disengage the electric clutch. Before leaving the seat, disengage the electric clutch, set the parking brake, stop the engine, remove the key, and wait for all moving parts to stop.

## WARNING

Perform the Safety System Interlock test found in your tractor Operator's Manual. If tractor does not pass the test, do not operate the tractor. See your authorized dealer. Under no circumstances should you attempt to defeat the safety system.

Use caution when clearing a snow covered area. Snow can cover objects such as curbs, drop-offs, and other obstacles. Be familiar with the area you are clearing.

To prevent an explosion or fire, never store the tractor with fuel in the tank inside a building where an ignition source is present.



### IMPORTANT NOTE

Always raise the snowthrower before turning or backing up to prevent damage to the unit.

## DANGER

### OPERATING ON SLOPES CAN BE DANGEROUS

Never operate on slopes greater than 17.6% (10°) which is a rise of 3-1/2 feet (106cm) vertically in 10 feet (607cm) horizontally.

Operate the unit at a slow ground speed when driving onto slope. Avoid using brakes to control ground speed.

When operating on slopes that are greater than 15 % (8.5°) but less than 17.6%, use additional wheel weights or counterweights.

In addition to counterweights, use extra caution when operating on slopes. Drive UP and DOWN the slope, never across the face, use caution when changing directions and DO NOT START OR STOP ON SLOPE.

For additional traction, tire chains and a weight box can be added. Maximum weight added to tractor should not exceed 50 lbs. per wheel and 100 additional lbs. in weight box.

### Transporting

1. Disengage the electric clutch and then raise the snowthrower.
2. Adjust ground speed according to surface conditions.
3. Select a low ground speed when transporting on a slippery surface.

# General Operating Instructions

---

## Snow Removal Suggestions

- Determine the best snow removal pattern before beginning.
- Wind direction is an important factor to consider. Rotate the spout to discharge snow downwind.
- Plan the pattern so that you avoid throwing snow on cleared areas and on yourself as you are operating.
- When land contour permits, it is best to travel in the longest direction to minimize turning.
- In very deep or heavy snow, it may be necessary to make the first pass with snowthrower partially raised, backing up every few feet and lowering the snowthrower to clear the snow left on the surface. Also, it may be necessary to slice off less than the full width of the auger or reduce ground speed.
- If snow stops flowing freely from the spout, back away until the snowthrower clears itself.

## DANGER

**If the auger stalls or the chute plugs, DISENGAGE THE ELECTRIC CLUTCH, STOP THE ENGINE AND REMOVE THE KEY. SET THE PARKING BRAKE. WAIT FOR MOVING PARTS TO STOP. Remove the foreign object or clear the spout with a piece of wood before restarting the engine. Never place hands into auger housing or spout to clear jammed object. Auger may rotate when object is removed.**

## Daily Storage

1. Run the snowthrower a few minutes after blowing snow to prevent freeze-up of auger.
2. Allow tractor engine to cool before storing in any enclosure.

## Off-Season Storage

1. Remove snowthrower from the tractor.
2. Use water pressure or a brush to thoroughly clean the housing.
3. Paint, or lightly coat with oil, any area where paint has been worn or chipped away.
4. Lubricate the snowthrower.
5. Store the snowthrower and hitch in a dry place.

## **⚠ WARNING**

To avoid serious injury, perform maintenance on the unit only when the engine is stopped and all moving parts have stopped. Always remove the ignition key before beginning maintenance or adjustments to prevent accidental starting of the engine.

### Schedule For Normal Care

Care Required	Schedule
Clean snow and ice from snowthrower.	After each use.
Lubricate snowthrower.	Every 10 hours or at least once a year.
Check gear box oil level.	At least once a year.

### General Lubrication

Lubricate the snowthrower as shown in Figure 2. Where an oil can is shown use 30 weight oil. Where a grease gun is shown, use lithium grease. Lubricate the following areas:

- Oil the chute deflector.
- Oil the deflector locking control.
- Grease the chute ring gear.
- Grease the snowthrower-hitch pivot points.
- Grease the auger bearings.
- Grease the the auger shaft grease fittings.

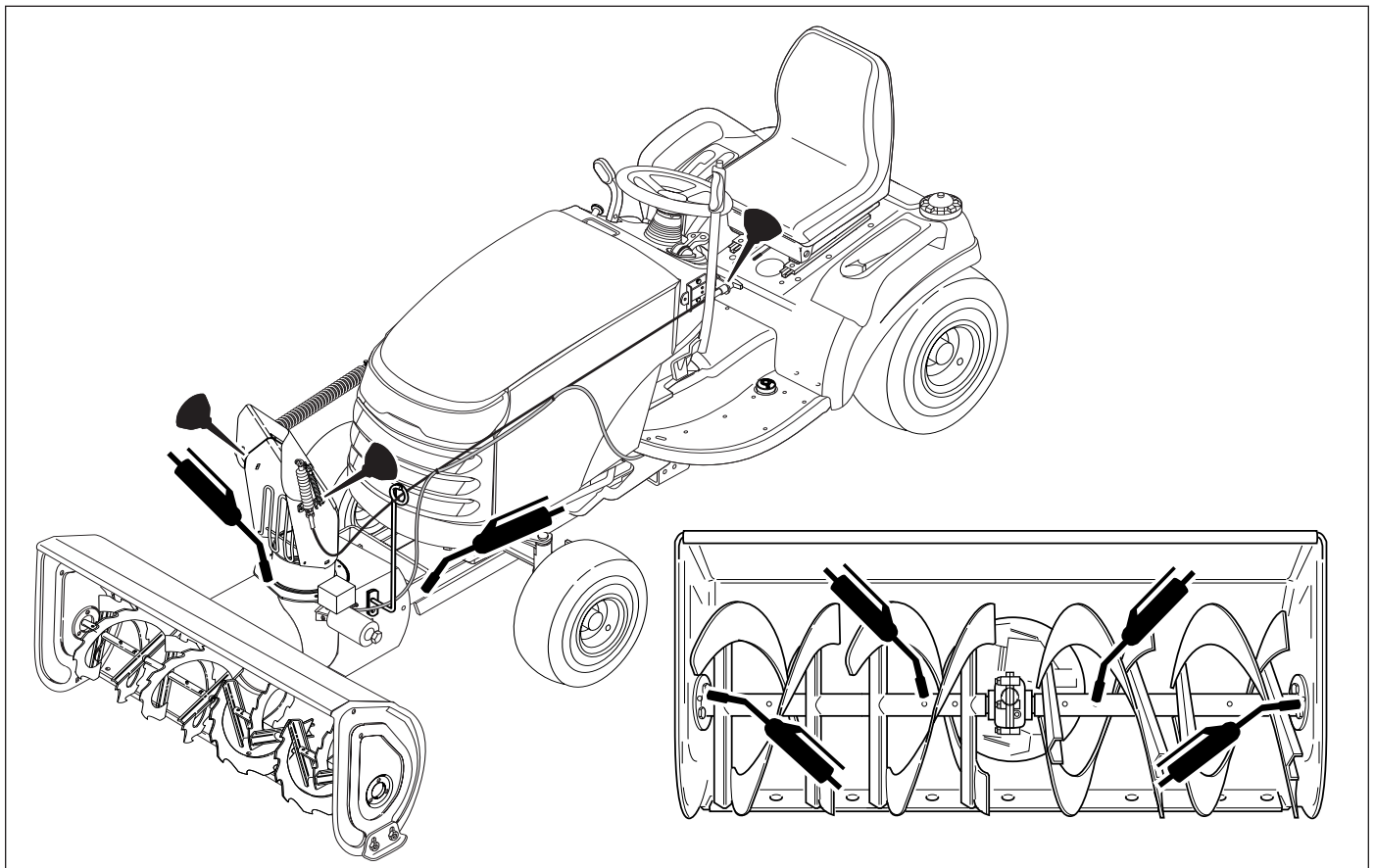


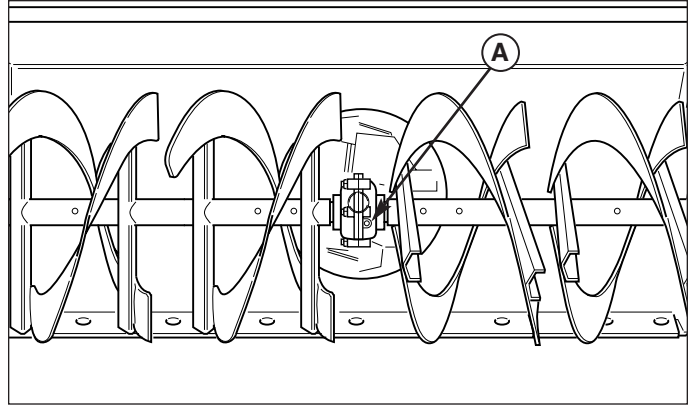
Figure 2. Lubrication Points

# Maintenance

## Check Auger Gearbox Oil Level

Perform this check every season.

1. Remove the plug (A, Figure 3) from the side of the auger gear box.
2. Add Simplicity Winter Weight Worm Gear Oil until the oil level is even with the fill plug hole.
3. Reinstall the plug (A).

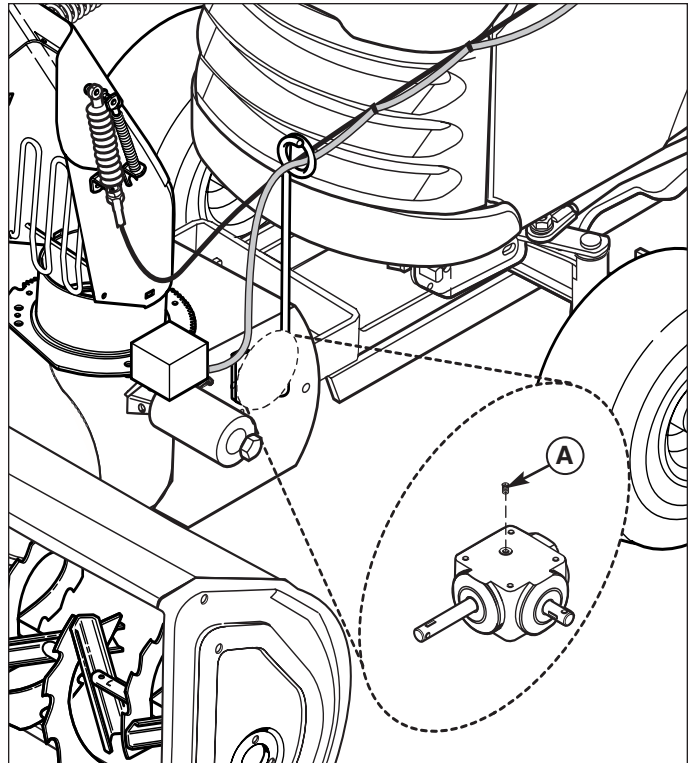


**Figure 3. Auger Gear Box Oil**  
**A. Fill Plug**

## Check the Impeller Gear Box Oil Level

Perform this check every season. The gear box oil capacity is 12 oz. The gear box can be accessed from the rear of the snowthrower attachment.

1. Remove the oil fill plug (A, Figure 4) from the top of the gear box.
2. Insert a piece of wire into the gear box to check the oil level.
3. Add 85W-90 gear lube oil if required. The box should be approximately half full. Air space is required for oil expansion.
4. Reinstall the plug.



**Figure 4. Impeller Gear Box Oil**  
**A. Fill Plug**



# Troubleshooting, Adjustments, & Service

## TROUBLESHOOTING

While normal care and regular maintenance will extend the life of your equipment, prolonged or constant use may eventually require that service be performed to allow it to continue operating properly.

The troubleshooting guide below lists the most common problems, their causes and remedies.

See the information on the following pages for instructions on how to perform most of these minor adjustments and service repairs yourself. If you prefer, all of these procedures can be performed for you by your local authorized dealer.

## WARNING

**To avoid serious injury, perform maintenance on the tractor or mower only when the engine is stopped and the parking brake engaged.**

**Always remove the ignition key, disconnect the spark plug wire and fasten it away from the plug before beginning the maintenance, to prevent accidental starting of the engine.**

PROBLEM	CAUSE/SOLUTION
1 Snowthrower auger does not rotate.	A. Electric clutch not engaged. Engage electric clutch. B. Foreign material is blocking auger. STOP engine. Remove key. Unplug auger with piece of wood. Read WARNING on page 5. C. Drive chain broken. Replace parts as required.
2 Auger does not stop when electric clutch is disengaged.	A. Electric clutch brake not operating properly. See your dealer.
3 Auger rotates, but snow is not thrown far enough.	A. Engine RPM too slow. Set throttle to FULL. B. Ground speed too fast. Use slow ground speed. C. Snowthrower discharge chute clogged. STOP engine. Remove key. Unplug discharge chute using a piece of wood. Read WARNING on page 5. D. Shear pin/bolt broken.
4 Scraper bar does not clean down to hard surface.	A. Skid shoes not properly adjusted. Adjust skid shoes. B. Lift height out of adjustment. See ADJUSTMENTS section. C. No down pressure. See Hitch Installation Instructions.
5 Snowthrower picks up and throws stones on gravel drive.	A. Skid shoes not properly adjusted for ground surface. Adjust skid shoes. B. Too much downward pressure on snowthrower. Raise snowthrower slightly. C. Downward pressure out of adjustment. See ADJUSTMENT section.
6 Tractor does not have sufficient traction.	A. Tractor too light at rear wheels. Use Quick Tach weights, wheel weights, and tire chains.
7 Tractor not stable on sloping surfaces.	A. Ground speed too fast. Reduce speed. B. Tractor not properly weighted. See Recommended Accessories, page 1. C. Slope grade too steep. See Safety Section. Use Quick Tach weights, wheel weights, and tire chains.
8 Chute does not rotate.	A. Rotator gears out of adjustment. B. Wire harness disconnected.

# Troubleshooting, Adjustments, & Service

## Skid Shoe Adjustment

On smooth surfaces such as concrete or asphalt, the scraper bar should scrape the surface. On surfaces such as gravel, the scraper bar should be set high enough so that it will not pick up debris.

1. Loosen the nuts securing the skid shoes (see Figure 5).
2. Raise or lower the scraper bar to the desired height. Use wood blocks to hold the snowthrower in position.
3. Set the skid shoes so that they are in contact with the ground and tighten the skid shoe nuts.

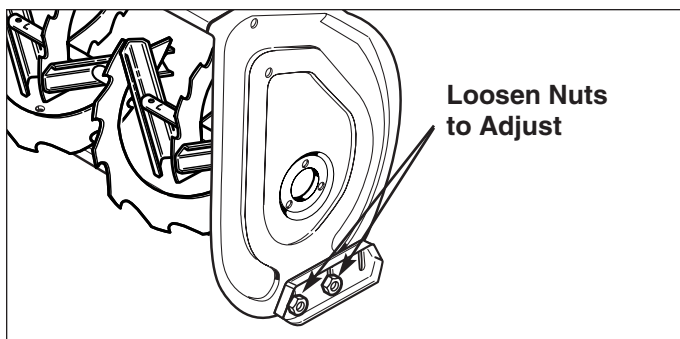


Figure 5. Adjusting Skid Shoes

## Electric Chute Rotator Gear

1. Remove the cover and loosen the three screws (A, Figure 6 or 7) securing the electric spout rotator motor.
2. Adjust the motor so that it meshes with the discharge chute ring gear and tighten the adjustment screws (A).
3. Reinstall the cover.

## Auger Shear Pins

The auger shear pins (A, Figure 8) are designed to break if the auger strikes an object. Replace the shear pins with original factory specification shear pins ONLY.

## Impeller Shear Bolt

The impeller shear bolt is designed to break if the auger strikes an object. The impeller shear bolt is located in the impeller shaft between the impeller and auger gear box. Replace the shear bolt ONLY with a 5/16-18 x 1 Grade 5 bolt.

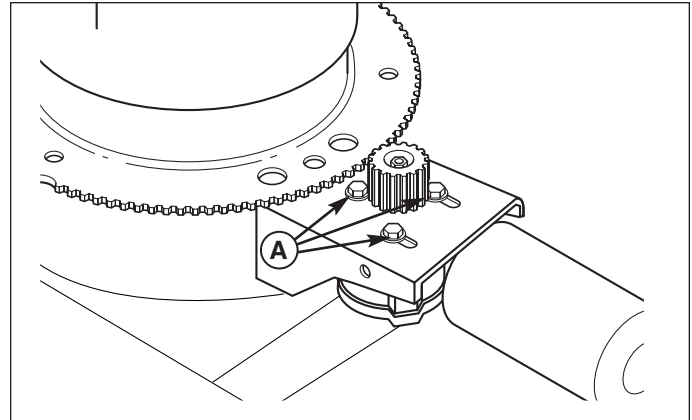


Figure 6. Chute Rotator Motor Adjustment (Left Side Mount)

A. Capscrews

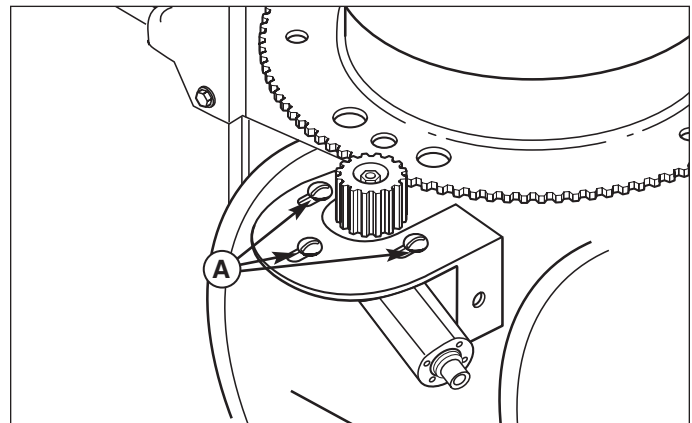


Figure 7. Chute Rotator Motor Adjustment (Right Side Mount)

A. Screws

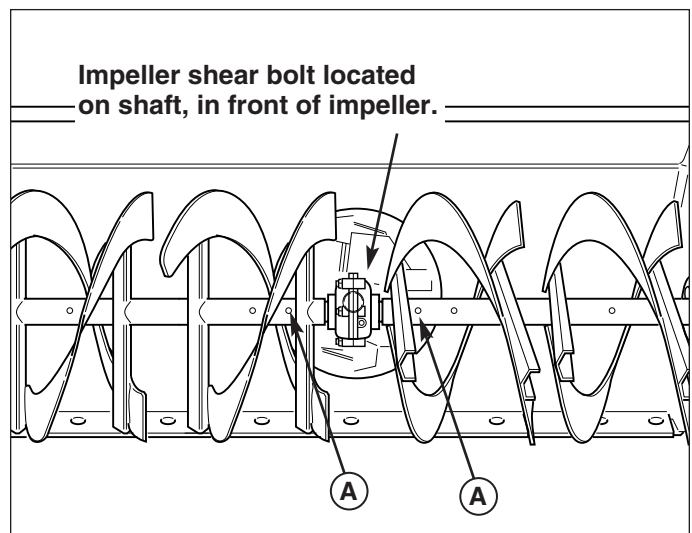


Figure 8. Shear Pins & Bolt

A. Auger Shear Pins

## Lift Adjustment

In the fully raised position the attachment should be 4"-5" off the ground. In the fully lowered position, the lift rod should compress the spring creating downward pressure on the snowthrower.

*NOTE: Always adjust the lift height before and after adjusting the downward pressure.*

### LIFT HEIGHT ADJUSTMENT

1. Fully raise the attachment lift. The snowthrower should be approximately 4"-5" off the ground. If not, go to step 2.
2. Lower the snowthrower and adjust the front set collar (A, Figure 9) to achieve the correct lift height.

### DOWNWARD PRESSURE ADJUSTMENT

*NOTE: Check that the lift bar or lock plate (Figures 14 & 15) are in the correct positions*

1. Place the lift in the fully raised position.
2. Release the rear set collar (C, Figure 9).
3. Slide the set collar (C) forward until it is slightly compressing the spring. Tighten the set collar screw. Do not over-compress the lift rod spring.

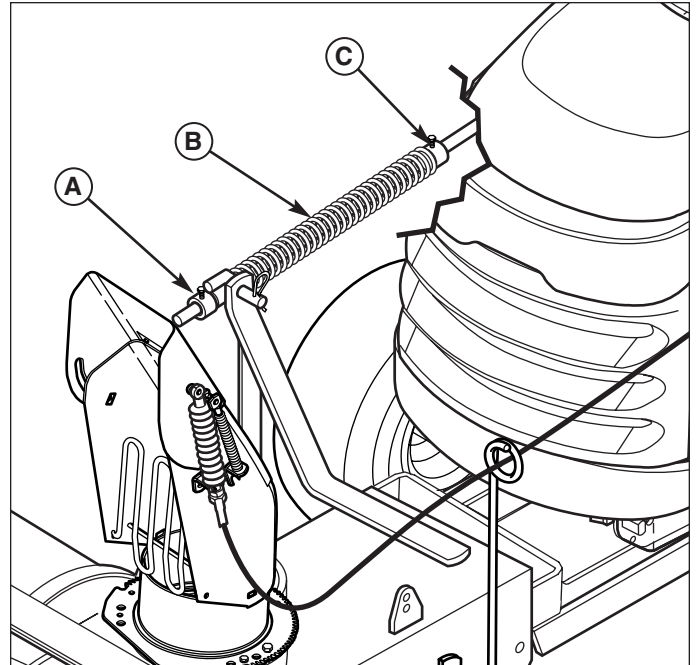
### LIFT ASSIST ADJUSTMENT (MANUAL LIFT ONLY)

1. Tighten the lift assist bolt (A, Figure 10) to increase the amount of lift assist.



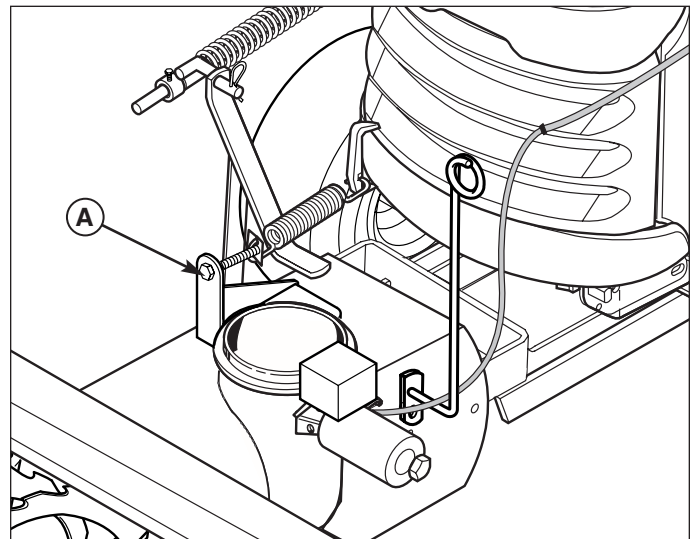
### IMPORTANT NOTE

DO NOT OVER-COMPRESS THE SPRING. In addition to providing downward pressure, the spring is an elastic medium that absorbs shocks caused by bumps and cracks in ground surfaces. Over-compressing the spring defeats this and may cause damage to the unit.



**Figure 9. Adjusting Lift Rod**

- A. Front Set Collar
- B. Spring
- C. Rear Set Collar



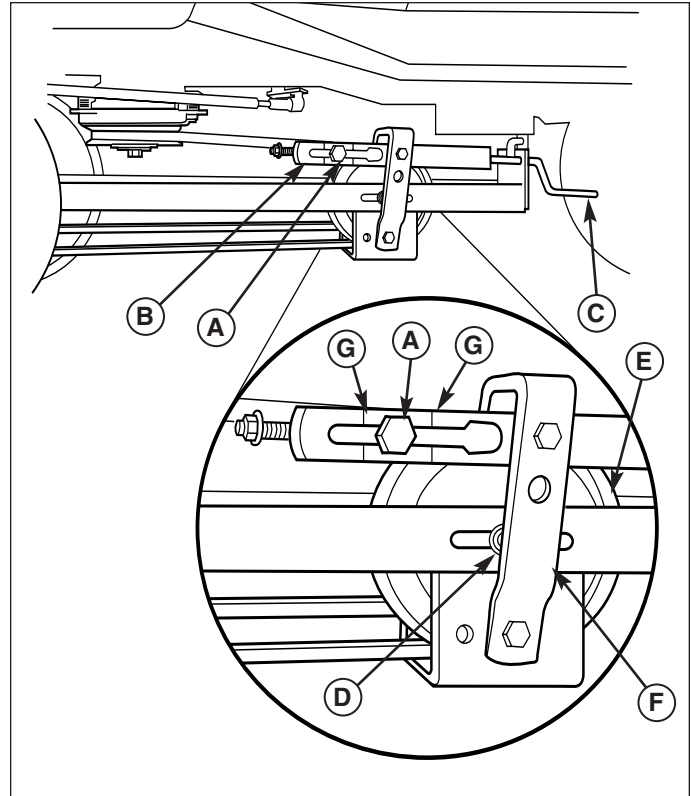
**Figure 10. Lift Assist Adjustment**

- A. Lift Assist Bolt

# Troubleshooting, Adjustments, & Service

## Belt Tension Adjustment

1. With the snowthrower drive belt installed, trunnion (A, Figure 11) should be between marks (G) on spring tension bracket (B) for correct belt tension.
2. Turn belt tension handle (C) to move trunnion (A) forward or rearward until it is between marks (G).
3. If trunnion cannot be placed between marks, loosen capscrew (D) and reposition idler pulley (E) as necessary. The pivot bracket (F) should be perpendicular to the hitch. Retighten capscrew (D) and repeat step 2.

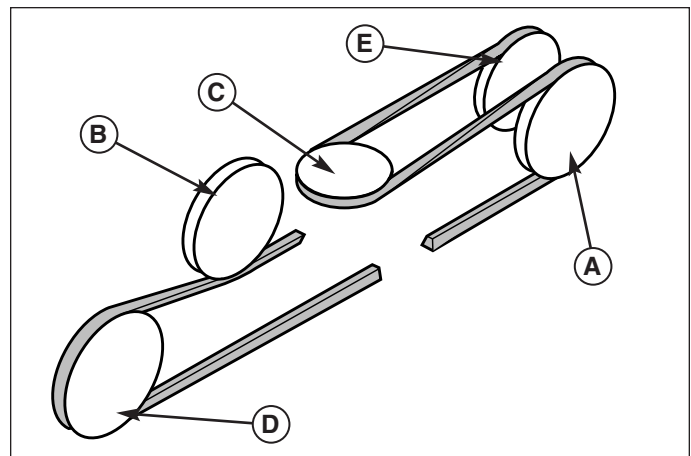


**Figure 11. Adjusting Belt Tension**

- |                                  |                         |
|----------------------------------|-------------------------|
| <b>A. Trunnion</b>               | <b>E. Idler Pulley</b>  |
| <b>B. Spring Tension Bracket</b> | <b>F. Pivot Bracket</b> |
| <b>C. Handle</b>                 | <b>G. Tension Marks</b> |
| <b>D. Capscrew</b>               |                         |

## Belt Replacement

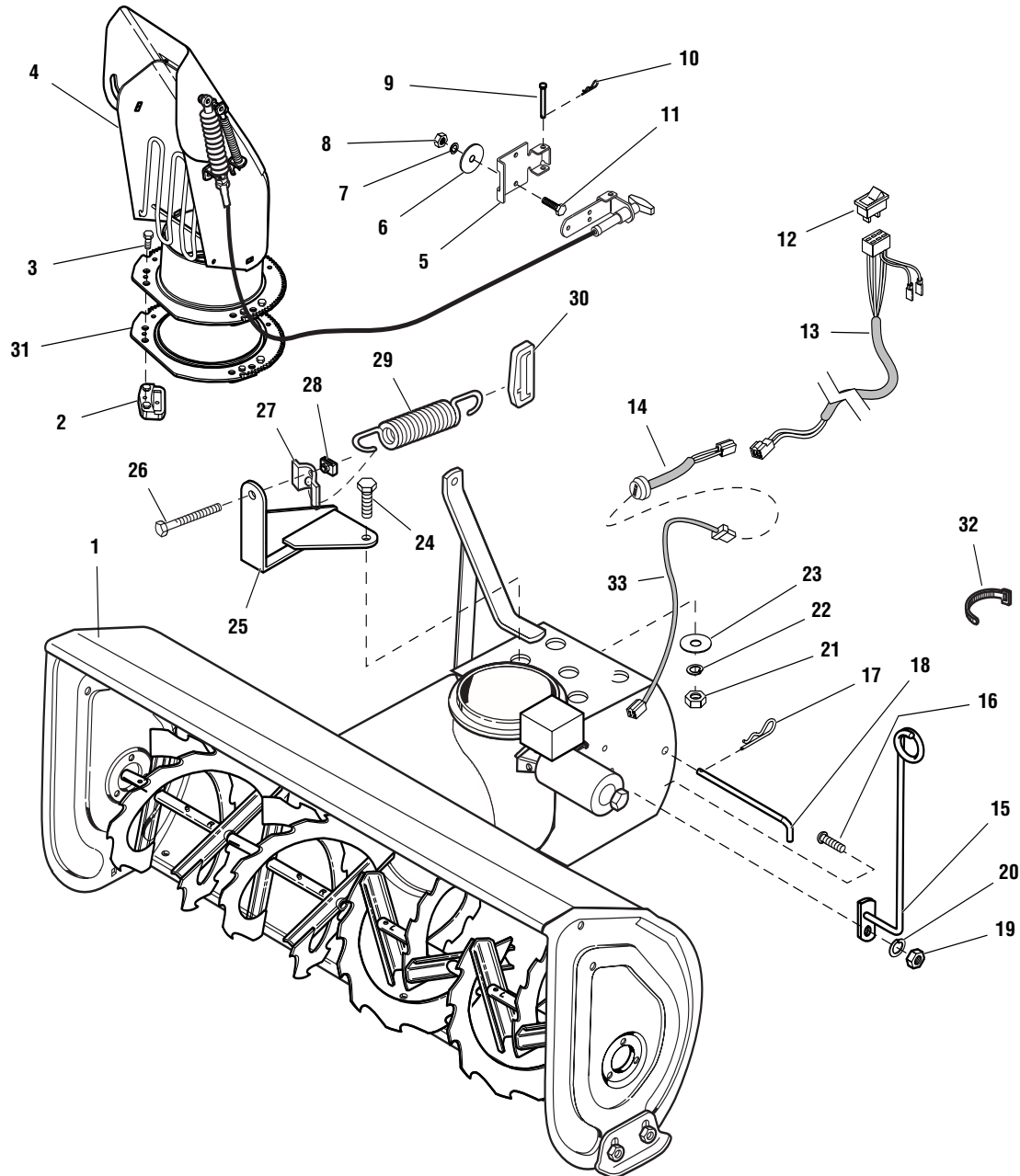
1. Loosen the drive belt by turning the handle (C, Figure 11).
2. Remove the belt from the pulley (D, Figure 12) inside the snowthrower and remove the snowthrower from the tractor.
3. Loosen the lockwashers and nuts securing two belt stops on idler pulleys (A and E, Figure 12).
4. Install new belt as shown.
5. Retighten belt stops and adjust the belt tension.



**Figure 12. Belt Routing**

- |   |
|---|
| <b>A. V-Pulley</b>                          |
| <b>B. Idler Pulley</b>                      |
| <b>C. Electric Clutch Pulley (V-pulley)</b> |
| <b>D. Snowthrower Pulley (V-pulley)</b>     |
| <b>E. Idler Pulley</b>                      |

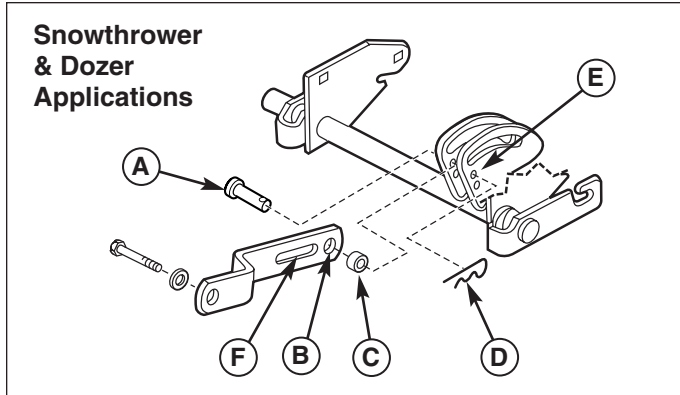




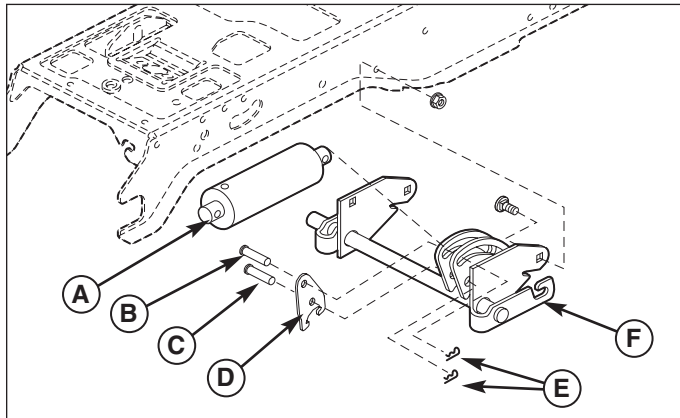
Ref	Qty	Description	Ref	Qty	Description	Ref	Qty	Description
1	1	SNOWTHROWER	12	1	SWITCH	23	1	WASHER, Over-size
2	3	GUIDE, Chute, Hold-Down	13	1	WIRE HARNESS, Switch	24	1	CAPSCREW, 5/16-18 x 1
3	3	SCREW, Plastite	14	1	WIRE HARNESS, Trailer Plug	25	1	BRACKET, Spring Anchor
4	1	DISCHARGE CHUTE ASSY.	15	1	SUPPORT	26	1	CAPSCREW, 5/16-18 x 4-1/2
5	1	MOUNTING BRACKET	16	1	CARRIAGE BOLT, 5/16-18 x 1	27	1	SPRING RETAINER
6	2	WASHER, Large	17	2	HAIR PIN CLIP	28	1	NUT, Cage
7	2	LOCKWASHER, 1/4"	18	2	ROD, Latch	29	1	SPRING, Lift Assist
8	2	NUT, 1/4-20	19	1	NUT, 5/16-18	30	1	ANCHOR, Spring
9	1	PIN	20	1	LOCKWASHER, 5/16	31	1	RING GEAR, Reinforcement
10	1	HAIR PIN CLIP	21	1	NUT, 5/16-18	32	1	TIE WRAP
11	2	CAPSCREW, 1/4-20 x 7/8	22	1	LOCKWASHER, 5/16	33	1	WIRE HARNESS, Motor

**Figure 13. Initial Setup (Left Side Mount Shown)**

# Initial Setup & Assembly



**Figure 14. Connect Lift Link - Manual Lift Models**  
**A. Pin**  
**B. Rear Hole of Lift Bar (Snowthrower & Dozer Applications)**  
**C. Spacer**  
**D. Hair Pin Clip**  
**E. Upper Hole (Snowthrower & Dozer Applications)**  
**F. Slot of Lift Link (Mower Applications)**  
**G. Lower Hole (Mower Applications)**



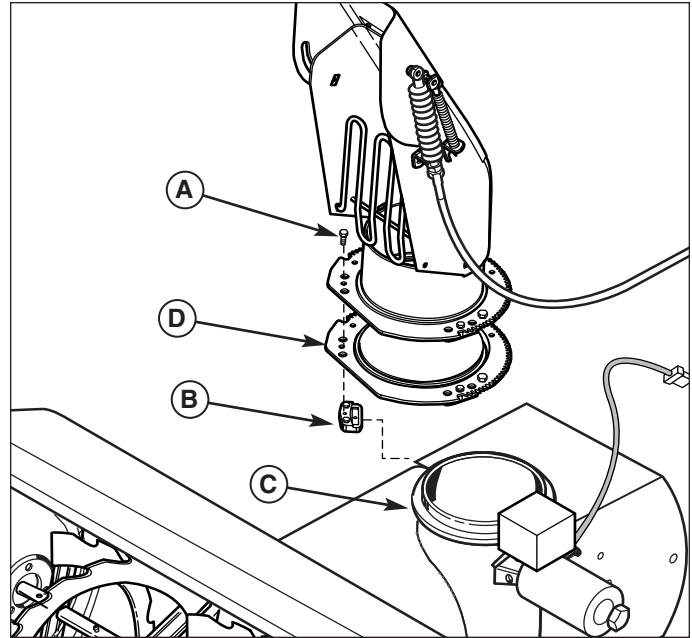
**Figure 15. Install Lock Plate - Hydraulic Lift Models**  
**A. Lift Cylinder**  
**B. Flat Head Pin (Original)**  
**C. Flat Head Pin (New)**  
**D. Lock Plate**  
**E. Hair Pin Clips**  
**F. Lift Shaft Assy.**

## INITIAL SETUP & ASSEMBLY

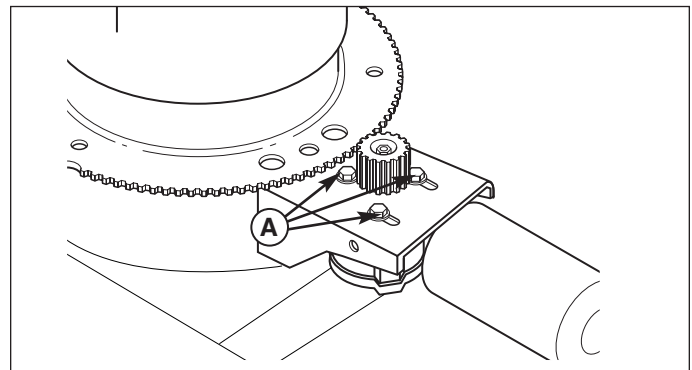
*NOTE: Some of the following setup procedures may already be completed.*

### Install Hitch

Install the sub-frame hitch. Refer to sub-frame hitch installation instructions for hitch modifications and 2-stage snowthrower drive belt installation for Conquest / 1700 / 2700 / GT and Lift Lever Kit 1694148. Note that the lift bar (B, Figure 14, manual lift models) or lock plate (D, Figure 15, hydraulic lift models) must be placed in the snowthrowing position (see page 22).



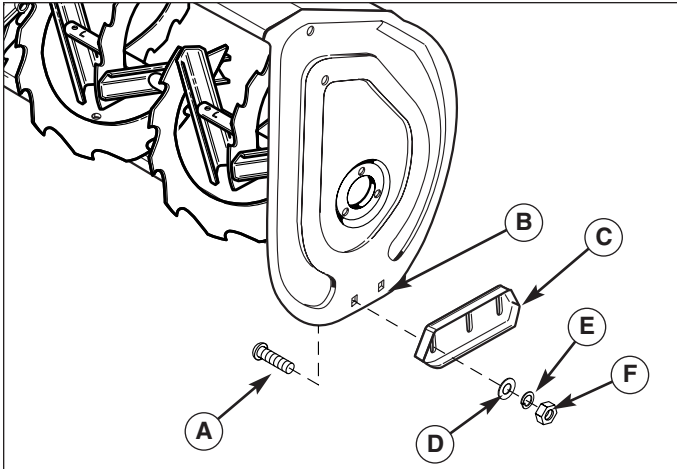
**Figure 16. Assemble Discharge Chute**  
**A. Plastite Screw**  
**B. Hold-Down**  
**C. Chute Ring**  
**D. Reinforcement Ring Gear**



**Figure 17. Discharge Chute Motor Adjustment**  
**A. Adjustment Screws**

### Assemble Discharge Chute

1. Locate the hold downs (B, Figure 16), reinforcement ring gear (D), and plastite screws (A).
2. Lubricate the base of the discharge chute and ring gear with automotive lithium grease.
3. Remove the cover and loosen the screws (A, Figure 17) securing the electric spout rotator motor.
4. Install the discharge chute and reinforcement ring gear (D), and secure to the chute ring (C, Figure 16) using the three hold downs (B) and plastite screws (A).
5. Adjust the motor so that it meshes with the discharge chute ring gear and tighten the adjustment screws (A, Figure 17).
6. Replace the cover.



**Figure 18. Skid Shoe Installation**  
**A. Carriage Bolt, 3/8-16 x 3/4"**  
**B. Snowthrower Housing**  
**C. Skid Shoe**  
**D. Washer**  
**E. Lockwasher**  
**F. Hex Nut**

## Install Skid Shoes

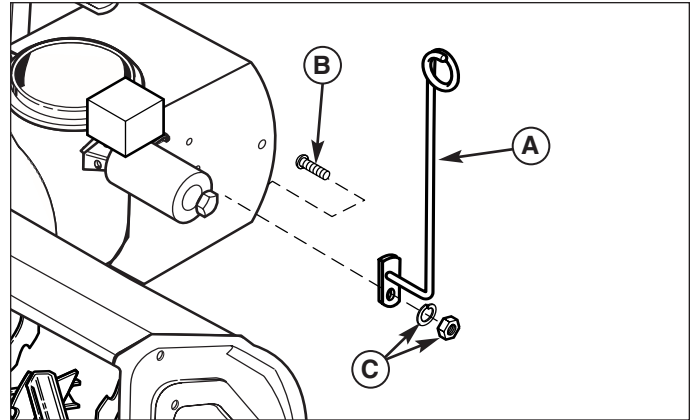
1. Install the skid shoes using 3/8-16 x 3/4" carriage bolts, washers, lockwashers, and nuts as shown in Figure 18.
2. Adjust the skid shoes. See Adjustments section.

## Attach Deflector Control Cable Support Arm

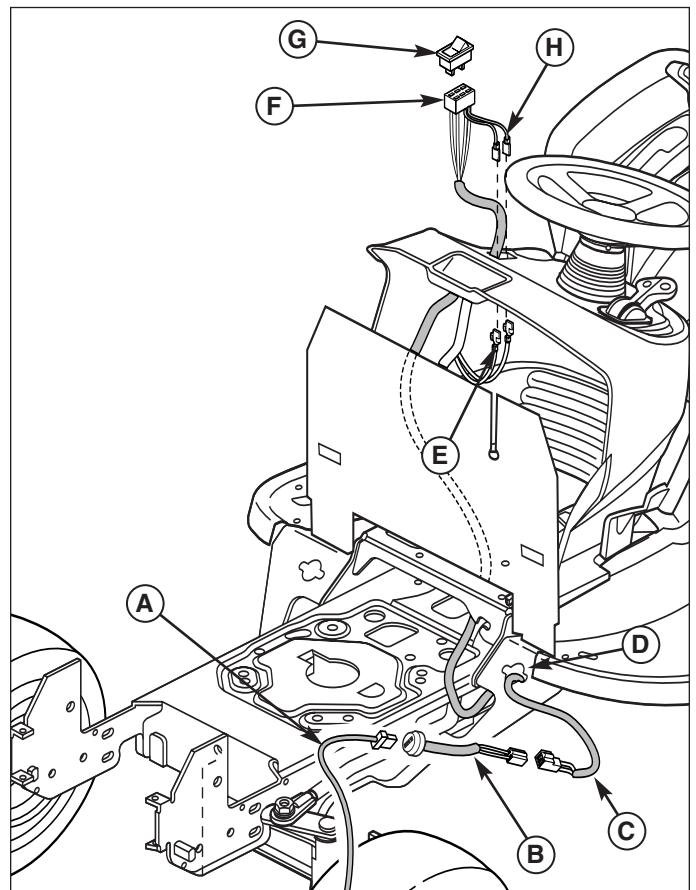
1. Assemble the deflector control cable support arm (A, Figure 19) to the left side of the snowthrower using one 5/16-18 x 1" carriage bolt (B), lockwasher, and nut (C) using the holes shown.

## Install Chute Rotator Switch and Harness

1. Remove the plug from the switch mounting hole in the right side of the dashboard.
2. Route the switch harness (C, F, Figure 20) through the frame and dashboard as shown.
3. Install the switch (G) in the dashboard and connect the upper end of the switch harness (F) to it.
4. Connect the red/yellow power lead (H) to the red/yellow tractor harness lead (E). Connect the black power lead to the black tractor harness lead.
5. Mount the trailer plug socket (B) in the frame at location (D). Connect the trailer plug lead (B) to the lower switch harness connector (C).
6. Do not connect the snowthrower wire harness (A) at this time.

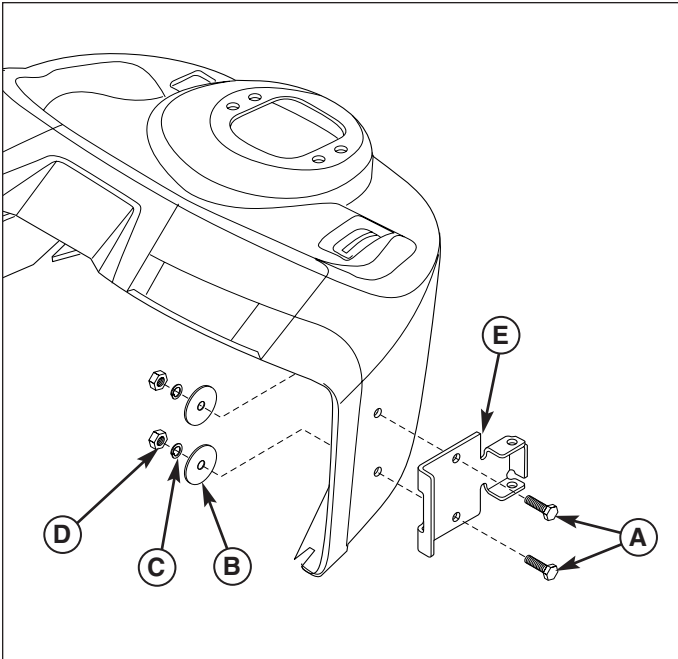


**Figure 19. Deflector Control Cable Support Arm**  
**A. Support Arm**  
**B. 5/16-18 x 1 Carriage Bolt**  
**C. Lockwasher & Nut**



**Figure 20. Install Power Port & Switch**  
**A. Rotator Motor Harness**  
**B. Trailer Plug**  
**C. Switch Harness Lower Plug**  
**D. Plug Hole (Frame)**  
**E. Tractor Harness Leads**  
**F. Switch Harness Upper Plug**  
**G. Switch**  
**H. Power Leads**

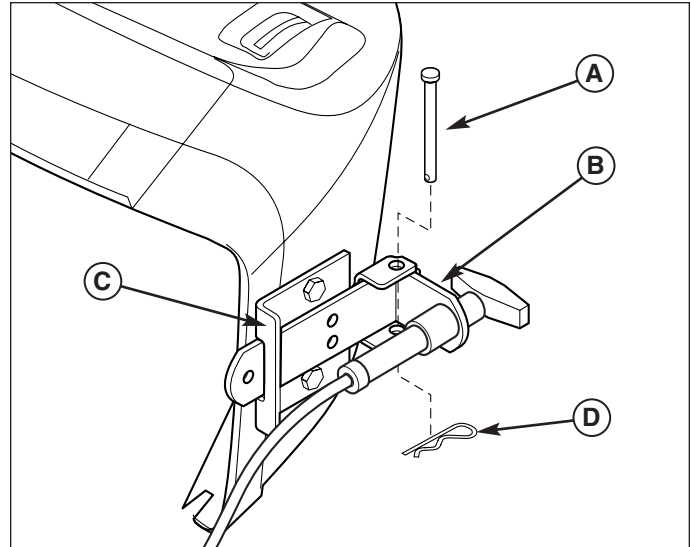
## Initial Setup & Assembly



**Figure 21. Mount Control Bracket - Current Models**  
A. 1/4-20 x 7/8 Capscrews      D. 1/4-20 Nuts  
B. 1/4 x 1-1/4 Flatwashers      E. Mounting Bracket  
C. 1/4 Lockwashers

### Mount Remote Deflector Control

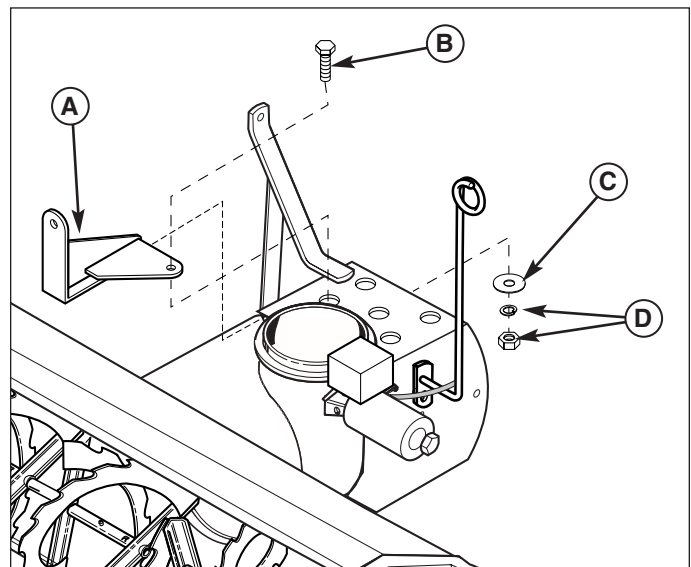
1. Using the template included in the back of this manual, drill two 9/32" holes in the dashboard to mount the remote chute control. See MOUNTING REMOTE DEFLECTOR CONTROL in the back of this book.
2. Mount the mounting bracket (E, Figure 21) to the dashboard. Secure with two 1/4-20 x 7/8 capscrews (A), lockwashers (C), and large flat washers (B).
3. Install the remote deflector control handle (B, Figure 22) in the mounting bracket (C) and secure with a clevis pin (A) and hair pin clip (D).



**Figure 22. Install Remote Deflector Control**  
A. Clevis Pin  
B. Deflector Control Handle  
C. Mounting Bracket  
D. Hair Pin Clip

### Mount Lift Assist Bracket (Manual Lift Models Only)

1. Mount the lift assist bracket (A, Figure 23) to the snowthrower. Slide the bracket back so that it engages the snowthrower housing. Secure using a 5/16-18 x 1 capscrew (B), large washer (C), lockwasher and nut (D).



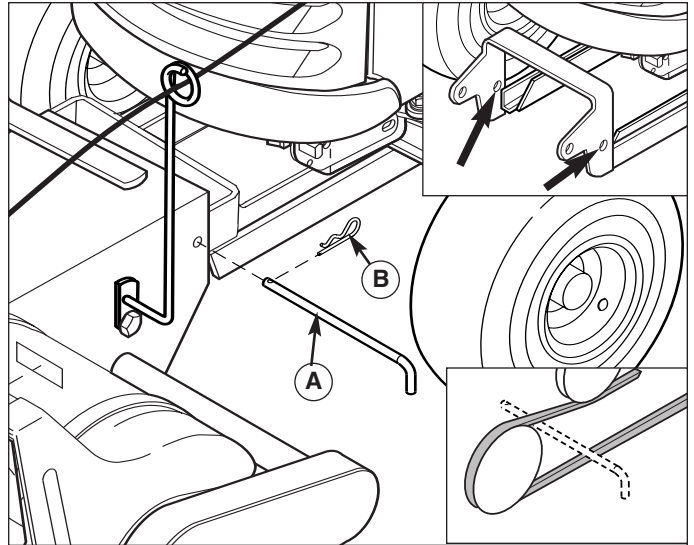
**Figure 23. Install Lift Assist Bracket**  
A. Lift Assist Bracket  
B. Capscrew, 5/16-18 x 1  
C. Large Washer  
D. Lockwasher & Nut

## Install Snowthrower

### CONNECT TO HITCH

1. Position the snowthrower in front of the hitch. Insert the hitch pin (A, Figure 24) through the snowthrower and hitch on both sides of the snowthrower. Secure with a hair pin clip (B). Use the back set of hitch holes (see inset).

**NOTE:** The hitch pin (A) goes in between the belt, NOT below or above it.

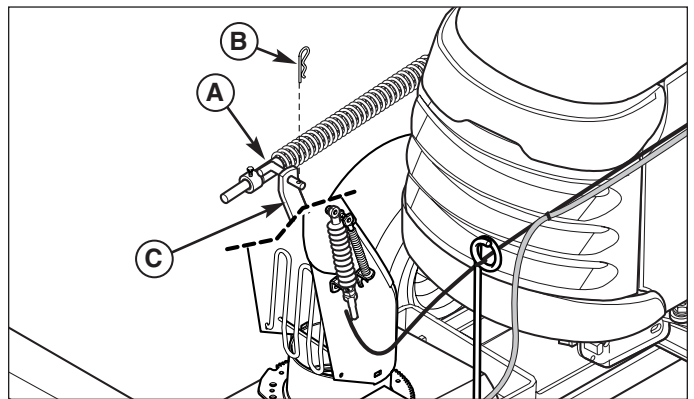


**Figure 24. Install Snowthrower**

- A. Hitch Pin
- B. Hair Pin Clip

### INSTALL LIFT ROD

2. Attach the front of the lift rod assembly (A, Figure 25) to the lift arm (C). Secure with a hair pin clip (B).



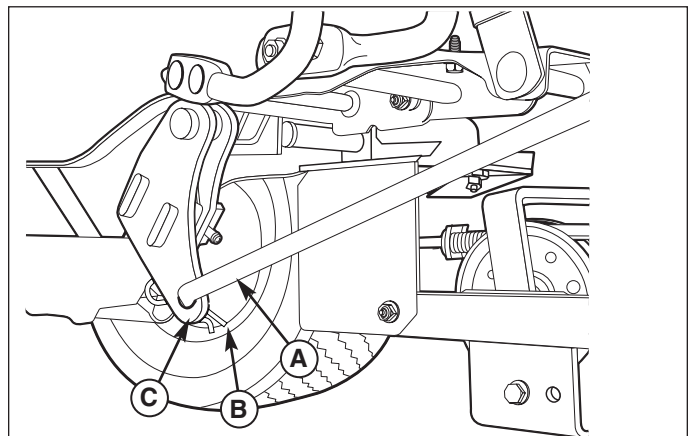
**Figure 25. Lift Rod - Front**

- A. Lift Rod Assembly
- B. Hair Pin Clip
- C. Lift Arm

3. Connect the rear of the lift rod assembly (A, Figure 26) to the tractor lift arm extension (C). Secure with a hair pin clip (B).

**NOTE:** If necessary, perform the lift rod adjustments found in the Troubleshooting, Adjustments, & Repair section.

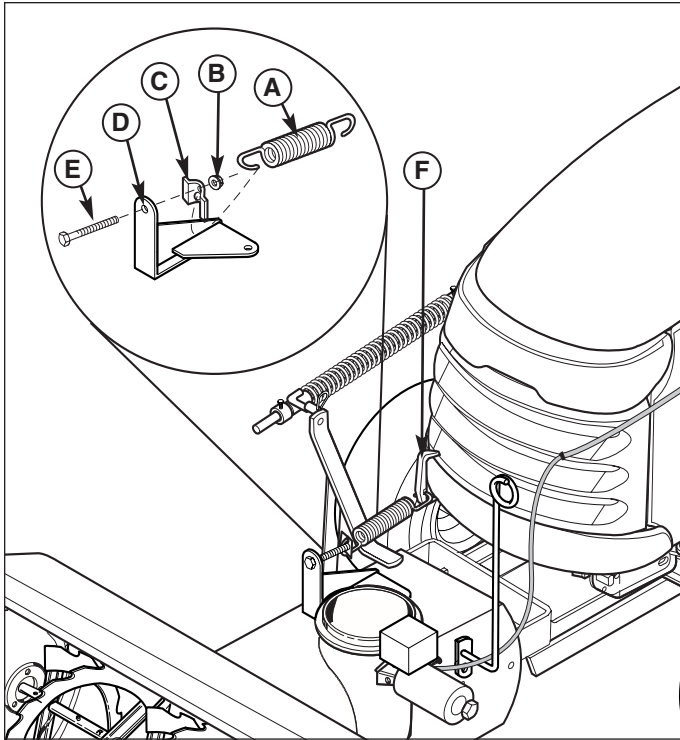
**NOTE:** See Lift Lever Kit Installation Instructions for lift rod installation.



**Figure 26. Lift Rod - Front**

- A. Lift Rod Assembly
- B. Hair Pin Clip
- C. Lift Arm

## Initial Setup & Assembly



**Figure 27. Install Lift Assist**

- A. Spring
- B. Nut
- C. Spring Retainer
- D. Assist Bracket
- E. Capscrew, 5/16-18 x 4-1/2
- F. Spring Anchor

### INSTALL LIFT ASSIST SPRING (MANUAL LIFT ONLY)

4. Install the spring anchor (F, Figure 27) on the bumper.
5. Install the lift assist spring (A), spring retainer (C), nut (B), and capscrew (E) through the assist bracket (D). Tighten until the desired amount of lift assist is achieved.

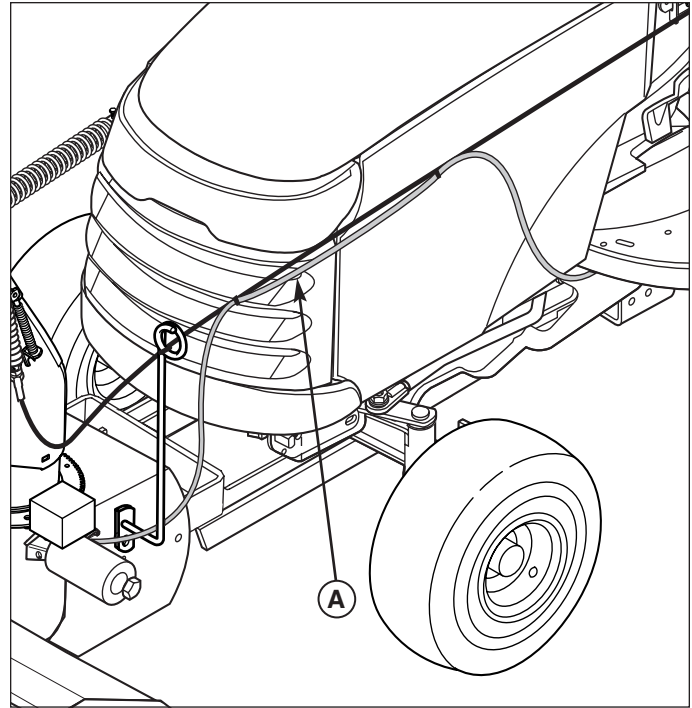
### CONNECT ELECTRICAL HARNESS (UNITS WITH LEFT SIDE MOUNTED MOTORS)

6. Route the wire harness (A, Figure 28) along the remote deflector control cable and secure with two wire ties. Connect the chute rotator harness plug (A, Figure 30) to the tractor plug (B). Make certain it will not be caught any linkages or moving parts.

### CONNECT ELECTRICAL HARNESS (UNITS WITH RIGHT SIDE MOUNTED MOTORS)

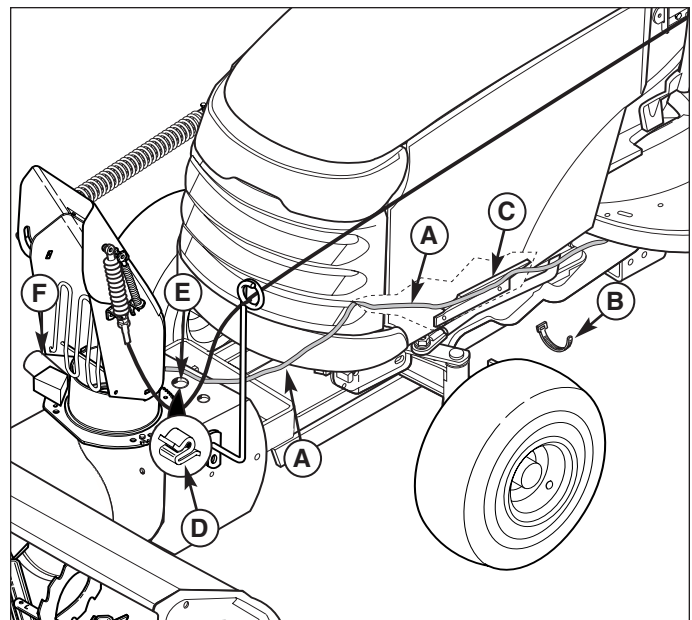
6. Raise the hood and route the wire harness (A, Figure 29) along the edge of the frame. Connect wire tie (B) loosely around the wire harness (A) and engine shield (C). Route the wire harness (A) through the lowest opening in grill as shown. Slide clip (D) onto hole (E). Place harness (A) into clip (D).

*Note: Leave the wire tie (B) loose to aid in seasonal removal of snowthrower.*



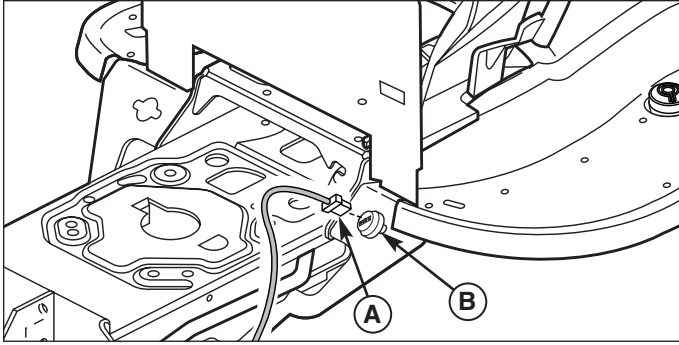
**Figure 28. Rotator Motor Electrical Connection (Left Side Mount)**

- A. Wire Harness

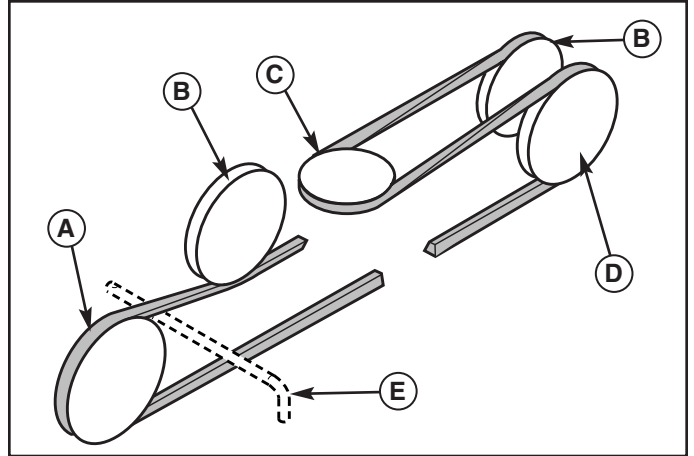


**Figure 29. Rotator Motor Electrical Connection (Right Side Mount)**

- A. Wire Harness
- B. Wire Tie
- C. Engine Shield
- D. Clip
- E. Hole in Housing
- F. Rotator Motor



**Figure 30. Rotator Motor Electrical Connection**  
**A. Rotator Motor Harness & Plug**  
**B. Tractor Plug**



**Figure 31. Belt Routing**  
**A. Snowthrower Pulley (V-pulley)**  
**B. Back-side Idler Pulley**  
**C. Electric Clutch Pulley (V-pulley)**  
**D. Idler Pulley (V-pulley)**  
**E. Hitch Pin**

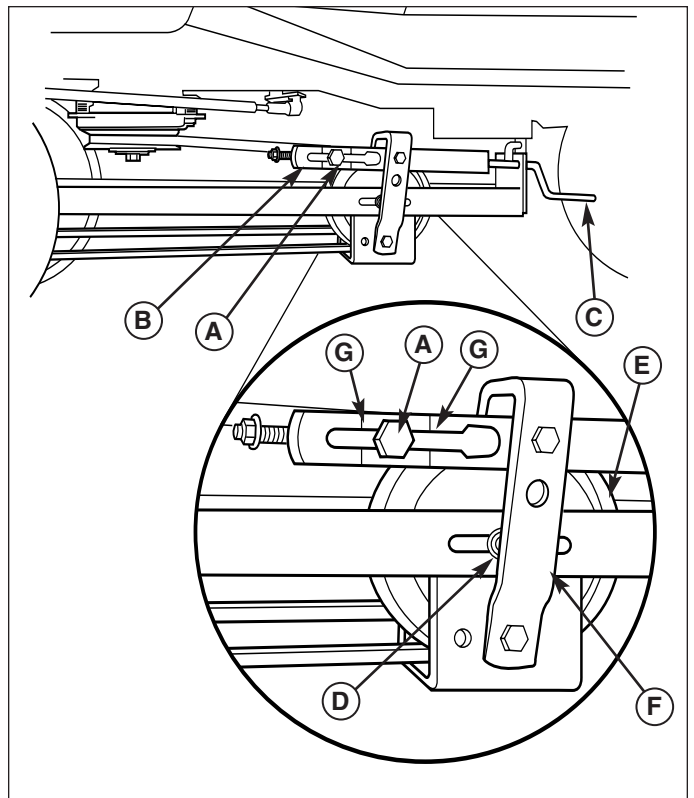
## INSTALL DRIVE BELT

7. Route the drive belt as shown in Figure 31. Note that the back of the belt rides in the back-side idlers (B).

**NOTE: The snowthrower hitch pin (E) goes in between the belt, NOT below or above it.**

8. With the snowthrower drive belt installed, the trunnion (A, Figure 32) should be between the marks (G) on spring tension bracket (B) for correct belt tension. Turn belt tension handle (C) to move trunnion forward or rearward until between marks.

If trunnion cannot be placed between marks, loosen capscrew (D) and reposition idler pulley (E) as necessary. The pivot bracket (F) should be perpendicular to snowthrower hitch.



**Figure 32. Adjusting Belt Tension**  
**A. Trunnion**  
**B. Spring Tension Bracket**  
**C. Handle**  
**D. Capscrew**  
**E. Idler Pulley**  
**F. Pivot Bracket**  
**G. Tension Marks**

# Removal & Normal Installation

Attach

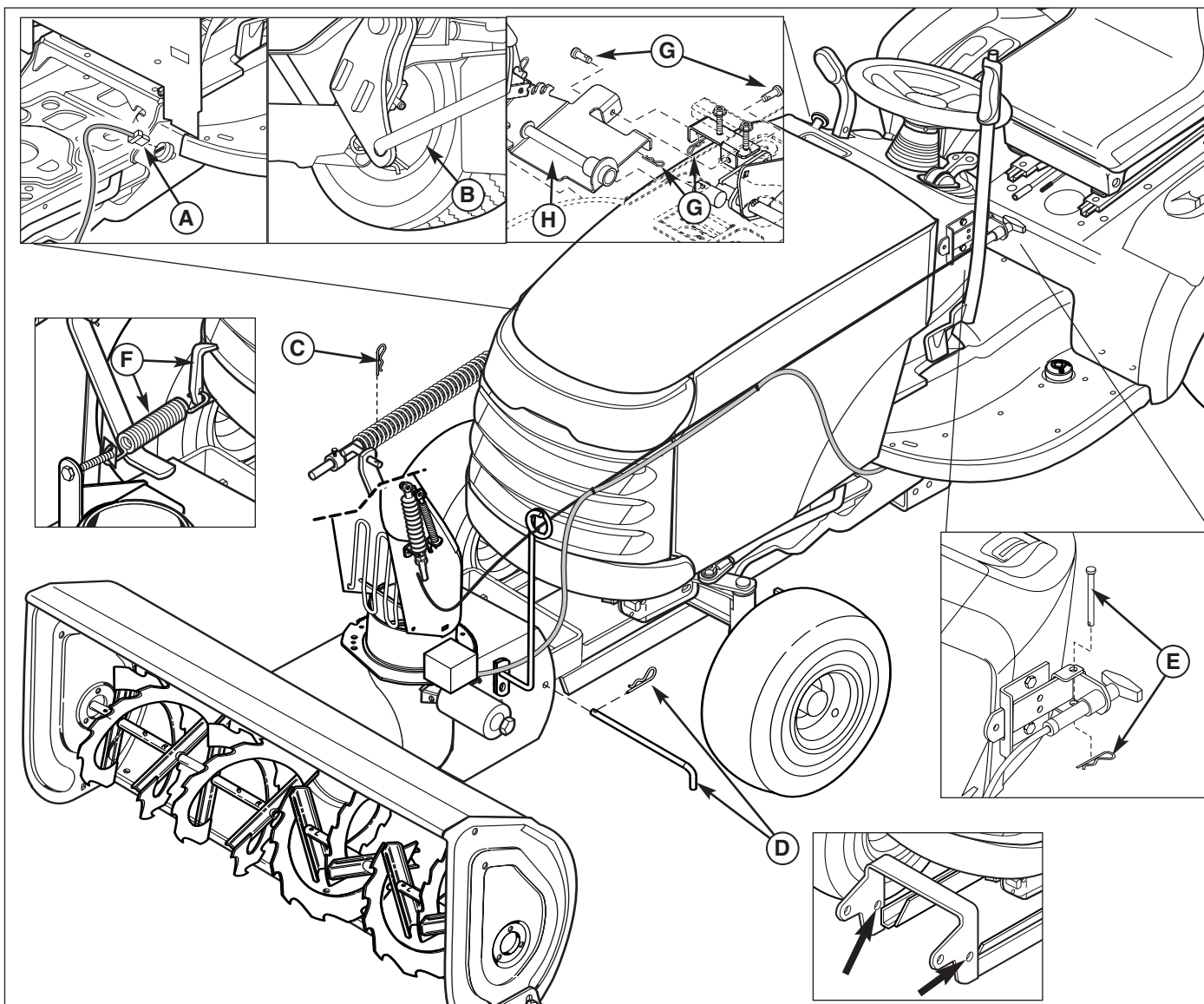


Figure 33. Removal

- A. Rotator Motor Plug
- B. Lift Rod
- C. Hair Pin Clip
- D. Hitch Pin & Clip

- E. Clevis Pin & Clip
- F. Assist Spring & Anchor
- G. Clevis Pin & Hair Pin
- H. RH Lift Lever Assembly

## Removal

1. Fully raise and support the snowthrower with wood blocks.
2. **Manual Lift Models:** Release and remove the lift assist spring and anchor (F, Figure 33).
3. Lower the snowthrower.
4. Remove the clevis pin and clip (E) from the remote deflector control and disconnect the control from the mounting bracket.
5. Disconnect the rotator motor plug (A).
6. Disconnect the rear of the lift rod (B) from the lift arm extension. Remove the hair pin clip (C) from the front of the lift rod. Remove the lift rod. Remove the lift arm extension from the tractor (see Hitch Installation Instructions).
7. Use the trunnion handle (C, Figure 34) to relieve belt tension. Remove the belt from the snowthrower drive pulley (A, Figure 35).



## Removing & Installing the Snowthrower

8. Remove the hitch pin and clip (D, Figure 33) from the snowthrower and remove the snowthrower. Reinstall all pins and clips to prevent loss.
9. Remove the clevis pin and hair pin (G, Figure 33 RH manual lift models) frame mounted bracket. Reinstall all pins and clips to prevent loss.
10. Return the lift bar (B, Figure 14, manual lift models) or lock plate (D, Figure 15, hydraulic lift models) to lawn mowing position.

### Normal Installation

1. Install the sub-frame hitch (see Hitch Installation Instructions). Be sure to install the down pressure lock plate or place the lift link in the snowthrower position (see Figures 14 & 15).
2. Place the snowthrower in front of the tractor and secure to the hitch using the hitch pin and clip (D, Figure 33).
3. Route the drive belt as shown in Figure 35. Note that the back of the belt rides in the back-side idler (B). Note that the pin (E) goes between the belt.
4. With the snowthrower drive belt installed, trunnion (A, Figure 34) should be between the marks (G) on spring tension bracket (B) for correct belt tension. Turn belt tension handle (C) to move trunnion forward or rearward until between marks.
5. Connect the rear of the lift rod (B, Figure 33) to the lift arm extension. Use a hair pin clip (C) to secure the front of the lift rod to the snowthrower.
6. Connect the rotator motor plug (A). Route the harness along the deflector control cable as shown.
7. Install the remote chute deflector control to the mounting plate and secure with a clevis pin and clip (E, Figure 33).
8. Fully raise and support the snowthrower with wood blocks. **Manual Lift Models:** Install the lift assist spring and anchor (F, Figure 33).
9. Install lift lever assembly (H, Figure 33 RH lift lever models) and secure with clevis pins and hair pins (G).
10. Place the lift bar (B, Figure 14, manual lift models) or lock plate (D, Figure 15, hydraulic lift models) in snowthrowing position.

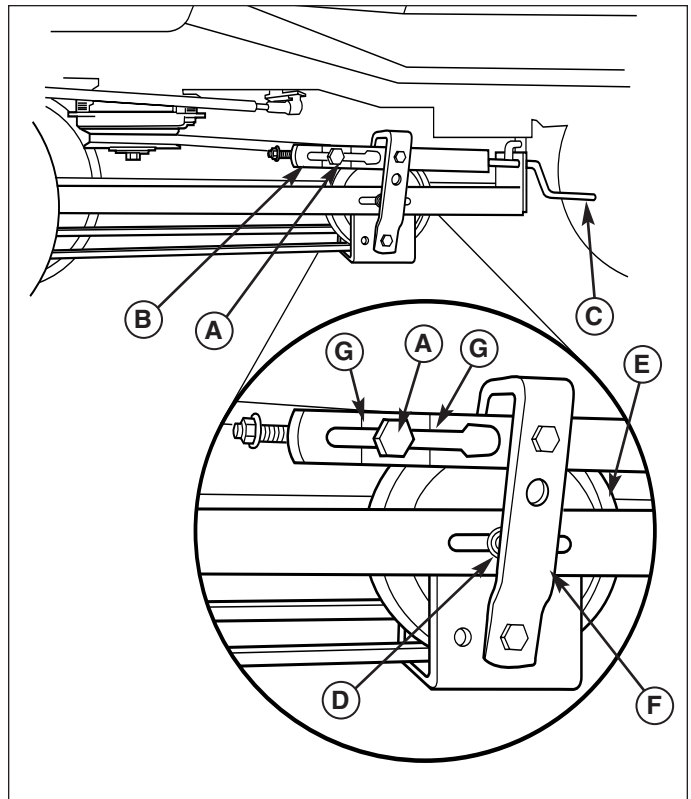


Figure 34. Adjusting Belt Tension

- |                           |                  |
|---------------------------|------------------|
| A. Trunnion               | E. Idler Pulley  |
| B. Spring Tension Bracket | F. Pivot Bracket |
| C. Handle                 | G. Tension Marks |
| D. Capscrew               |                  |

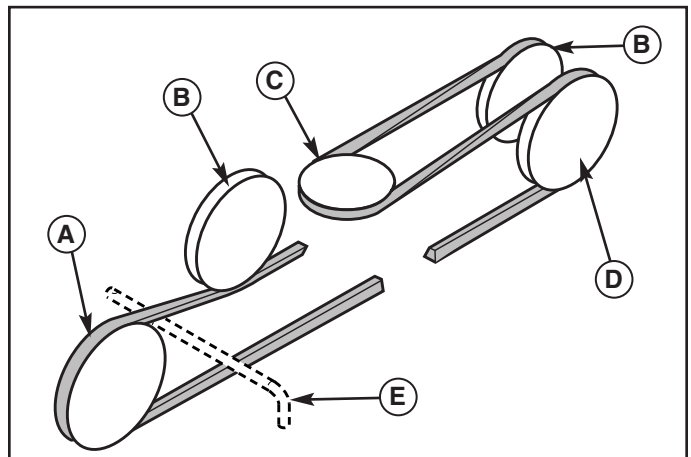


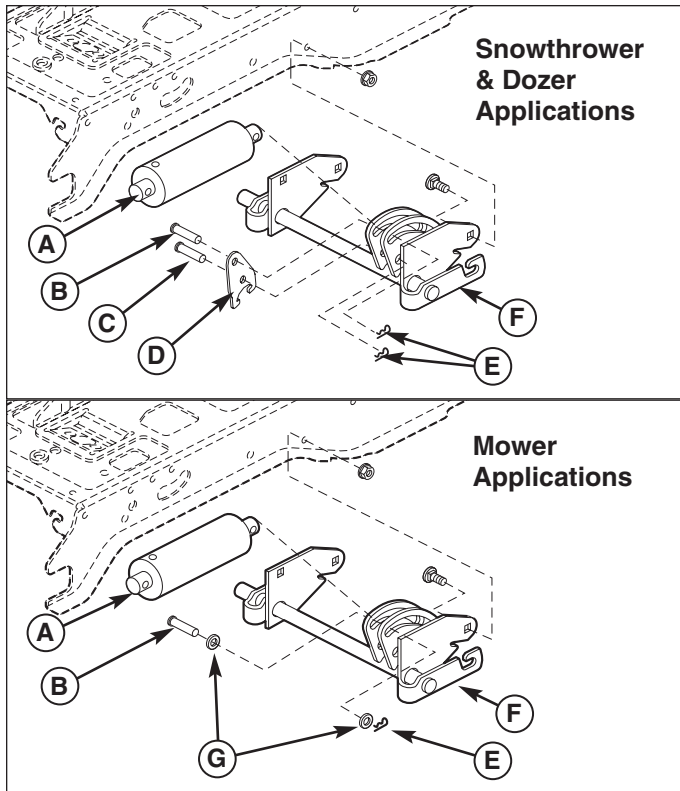
Figure 35. Belt Routing

- |                                      |
|--------------------------------------|
| A. Snowthrower Pulley (V-pulley)     |
| B. Back-side Idler Pulley            |
| C. Electric Clutch Pulley (V-pulley) |
| D. Idler Pulley (V-pulley)           |
| E. Hitch Pin                         |

## CAUTION

Spring under tension. Keep clear of pinch points.

# Lift Variations When Using Attachments



**Figure 36. Lift Lock Plate - Hydraulic Lift Models**

- A. Lift Cylinder
- B. Flat Head Pin (Original)
- C. Flat Head Pin (New)
- D. Lock Plate
- E. Hair Pin Clips
- F. Lift Shaft Assy.
- G. Washers

## LIFT VARIATIONS WHEN USING ATTACHMENTS

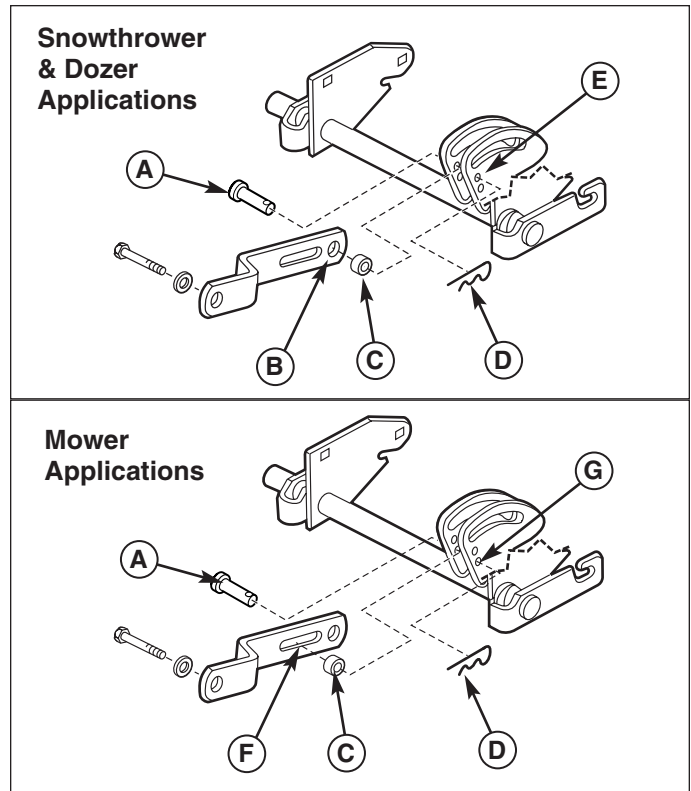
When a front-mounted attachment such as a snowthrower or dozer blade is used with the tractor, the lift mechanism must be locked to provide downward force. When the mower is reinstalled the downward pressure lock must be released so that the mower can float.

### Hydraulic Lift Models

When using a snowthrower or dozer, the downward pressure lock plate (D, Figure 36) and an additional pin (C) is installed. These parts are included with the attachment. Note that the washers (G) are not used with the lock plate.

When mowing, the downward pressure lock plate (D) is removed and replaced with two washers (G). The additional pin (C) is also removed.

Fully lower the hydraulic lift. The lift assembly is spring loaded so it will need to be held in the down position to perform of the following procedures.



**Figure 37. Lift Link - Manual Lift Models**

- A. Pin
- B. Rear Hole of Lift Bar (Snowthrower & Dozer Applications)
- C. Spacer
- D. Hair Pin Clip
- E. Upper Hole (Snowthrower & Dozer Applications)
- F. Slot of Lift Link (Mower Applications)
- G. Lower Hole (Mower Applications)

### Manual Lift Models

*NOTE: These instructions apply to Conquest / 1700 / 2700 / YT Series tractors or Broadmoor / 1600 / 2600 / LT Series tractors equipped with a lift lever kit 1694148.*

The lift link is installed differently depending on what attachment is being used. Refer to Figure 37 for link installation information.

# Hardware Identification & Torque Specifications

## Common Hardware Types

Hex Head Capscrew



Carriage Bolt

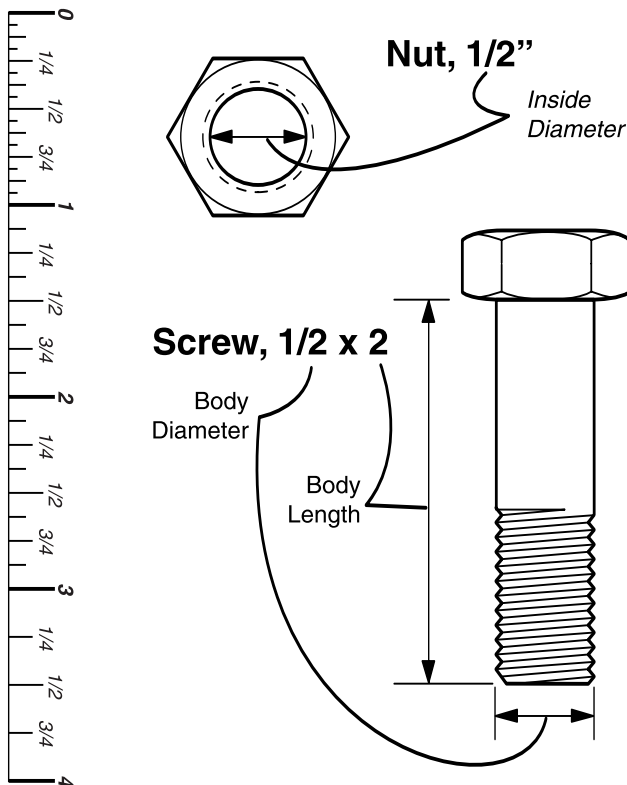


## Standard Hardware Sizing

When a washer or nut is identified as **1/2"**, this is the *Nominal size*, meaning the *inside diameter* is 1/2 inch; if a second number is present it represent the *threads per inch*

When bolt or capscrew is identified as **1/2 - 16 x 2"**, this means the *Nominal size*, or *body diameter* is 1/2 inch; the second number represents the *threads per inch* (16 in this example, and the final number is the *body length* of the bolt or screw (in this example 2 inches long).

**The guides and ruler furnished below are designed to help you select the appropriate hardware and tools.**



Torque Specification Chart						
FOR STANDARD MACHINE HARDWARE (Tolerance ± 20%)						
Hardware Grade	No Marks SAE Grade 2		SAE Grade 5		SAE Grade 8	
	in/lbs ft/lbs	Nm.	in/lbs ft/lbs	Nm.	in/lbs ft/lbs	Nm.
8-32	19	2.1	30	3.4	41	4.6
8-36	20	2.3	31	3.5	43	4.9
10-24	27	3.1	43	4.9	60	6.8
10-32	31	3.5	49	5.5	68	7.7
1/4-20	66	7.6	8	10.9	12	16.3
1/4-28	76	8.6	10	13.6	14	19.0
5/16-18	11	15.0	17	23.1	25	34.0
5/16-24	12	16.3	19	25.8	27	34.0
3/8-16	20	27.2	30	40.8	45	61.2
3/8-24	23	31.3	35	47.6	50	68.0
7/16-14	30	40.8	50	68.0	70	95.2
7/16-20	35	47.6	55	74.8	80	108.8
1/2-13	50	68.0	75	102.0	110	149.6
1/2-20	55	74.8	90	122.4	120	163.2
9/16-12	65	88.4	110	149.6	150	204.0
9/16-18	75	102.0	120	163.2	170	231.2
5/8-11	90	122.4	150	204.0	220	299.2
5/8-18	100	136	180	244.8	240	326.4
3/4-10	160	217.6	260	353.6	386	525.0
3/4-16	180	244.8	300	408.0	420	571.2
7/8-9	140	190.4	400	544.0	600	816.0
7/8-14	155	210.8	440	598.4	660	897.6
1-8	220	299.2	580	788.8	900	1,244.0
1-12	240	326.4	640	870.4	1,000	1,360.0

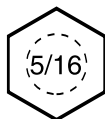
**NOTES**

- These torque values are to be used for all hardware excluding: locknuts, self-tapping screws, thread forming screws, sheet metal screws and socket head setscrews.
- Recommended seating torque values for locknuts:
  - for prevailing torque locknuts - use 65% of grade 5 torques.
  - for flange whizlock nuts and screws - use 135% of grade 5 torques.
- Unless otherwise noted on assembly drawings, all torque values must meet this specification.

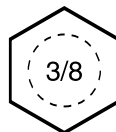
## Wrench & Fastener Size Guide



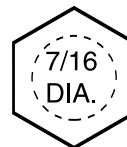
**1/4" Bolt or Nut**  
Wrench—7/16"



**5/16" Bolt or Nut**  
Wrench—1/2"



**3/8" Bolt or Nut**  
Wrench—9/16"



**7/16" Bolt or Nut**  
Wrench (Bolt)—5/8"  
Wrench (Nut)—11/16"



**1/2" Bolt or Nut**  
Wrench—3/4"

# Mounting Remote Deflector Control

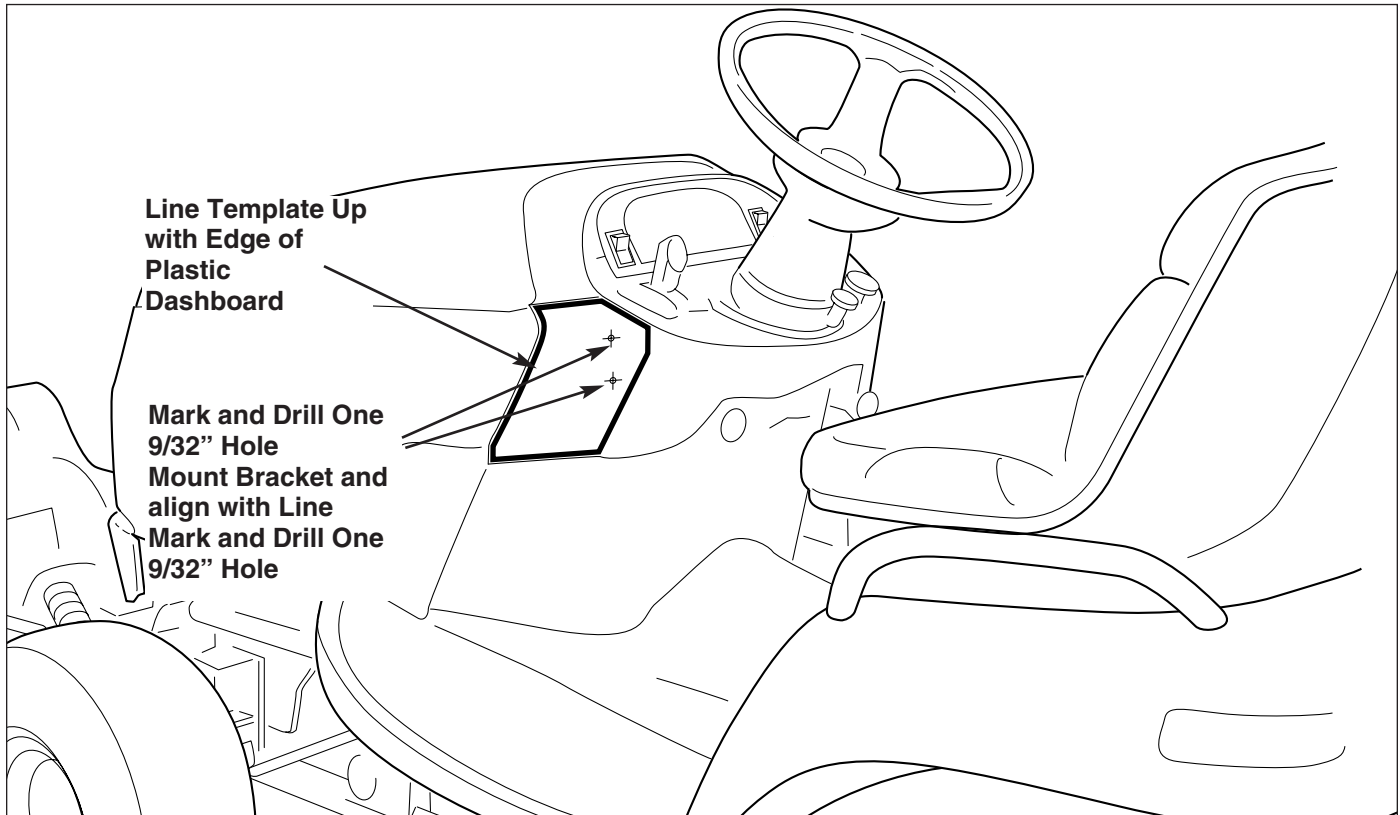


Figure 37. Template Location

## MOUNTING REMOTE DEFLECTOR CONTROL

**NOTE:** Read through instructions before beginning.

1. Open the hood.
2. Cut out the template and place it on the lower left corner of the dashboard as shown above.
3. Mark and drill one 9/32" hole using the template to locate the holes.
4. Mount the remote deflector mounting bracket (E, Figure 38) control to the dashboard using upper hole.
5. Align center of lower hole to dashed line on template and mark. Remove the remote deflector mounting bracket (E). Drill one 9/32" hole using the marked location.
6. Mount the remote deflector mounting bracket (E) control to the dashboard. Secure using two 1/4-20 x 7/8" capscrews (A) through the bracket (E) and dashboard.
7. Secure with 1/4 x 1-1/4 flatwashers (B), lockwashers (C), and nuts (D) on the BACKSIDE of the dashboard.

**DO NOT OVER-TORQUE.** Over-torquing may crack the dashboard.

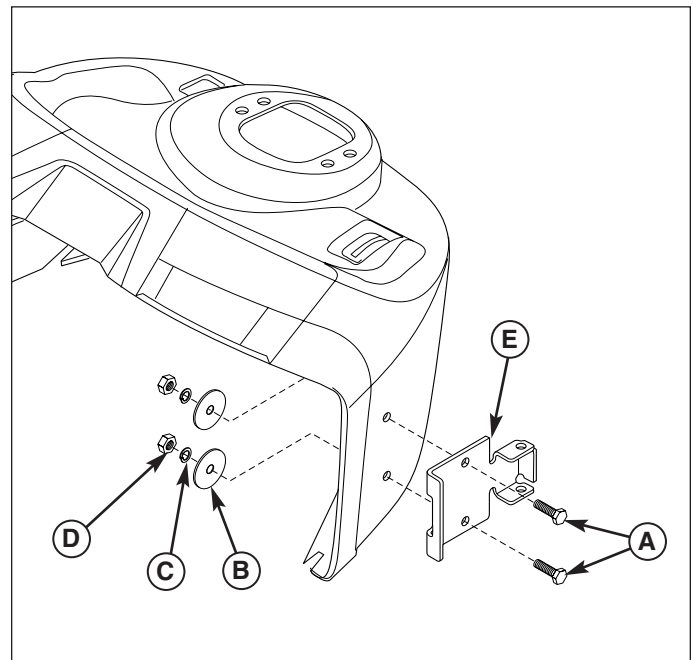
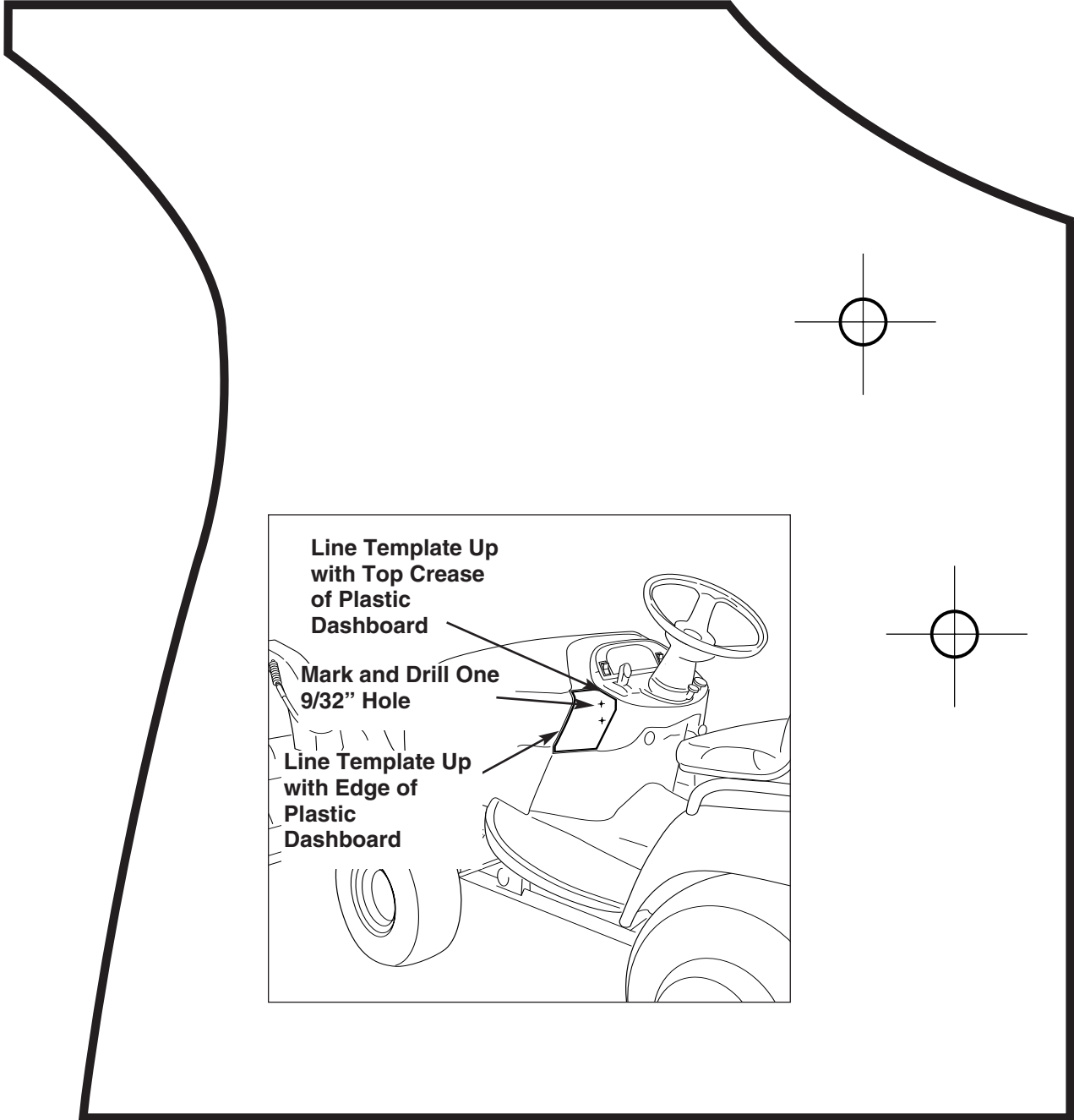


Figure 38. Mount Control Bracket - Current Models  
A. 1/4-20 x 7/8 Capscrews  
B. 1/4 x 1-1/4 Flatwashers  
C. 1/4 Lockwashers  
D. 1/4-20 Nuts  
E. Mounting Bracket





MANUFACTURING, INC.  
500 N Spring Street / PO Box 997  
Port Washington, WI 53074-0997

[www.SimplicityMfg.com](http://www.SimplicityMfg.com)



500 N Spring Street / PO Box 997  
Port Washington, WI 53074-0997

[www.MasseyLawn.com](http://www.MasseyLawn.com)



PRODUCTS  
535 Macon Street  
McDonough, GA 30253

[www.Snapper.com](http://www.Snapper.com)



500 N Spring Street / PO Box 997  
Port Washington, WI 53074-0997

[AGCOLawn.com](http://AGCOLawn.com)