

# Attachment Illustrated Parts List



## Attachment

**Mfg. No. Description**  
1692150 Catcher, Clean Sweep Twin, 34"

## **Simplicity**

MANUFACTURING, INC.  
500 N. Spring Street / PO Box 997  
Port Washington, WI 53074-0997 USA

[www.simplicitymfg.com](http://www.simplicitymfg.com)

© Copyright 2008 Simplicity Manufacturing, Inc. All Rights Reserved. Printed In USA.

**Part No.:** 1730792

**Rev.** 03/2008

TP 400-2442-01-AT-SMA

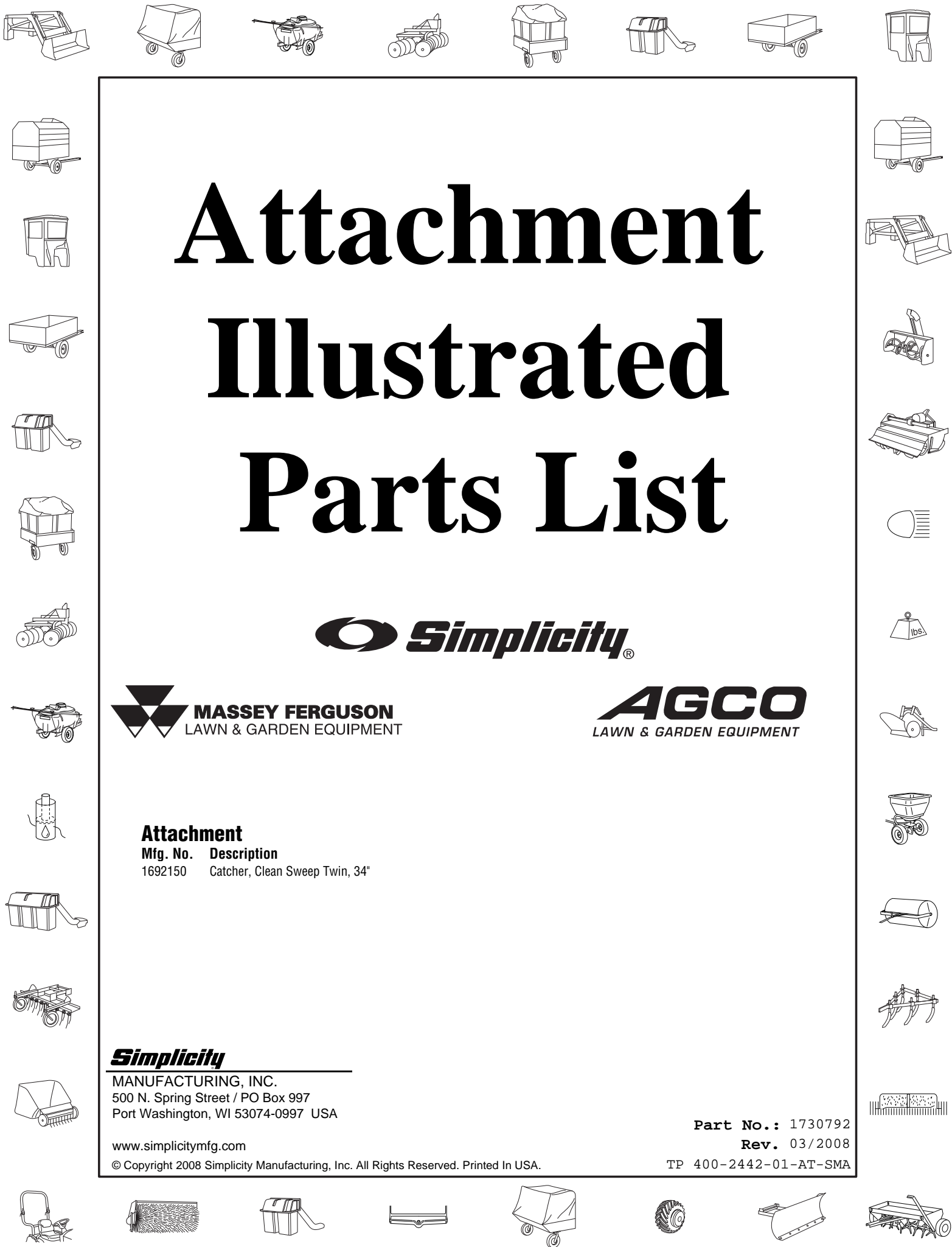



<b>PRODUCT COMPONENTS</b>	<b>PAGES</b>
Adapter, Blade & Tube Group .....	4
Cover & Bag Group - Twin .....	6
Hitch Group .....	8
<b>Torque Specification Chart .....</b>	<b>Inside Back Cover</b>

## Adapter, Blade & Tube Group

984490

NOTE: Unless noted otherwise,  
use the standard hardware torque  
specification chart.

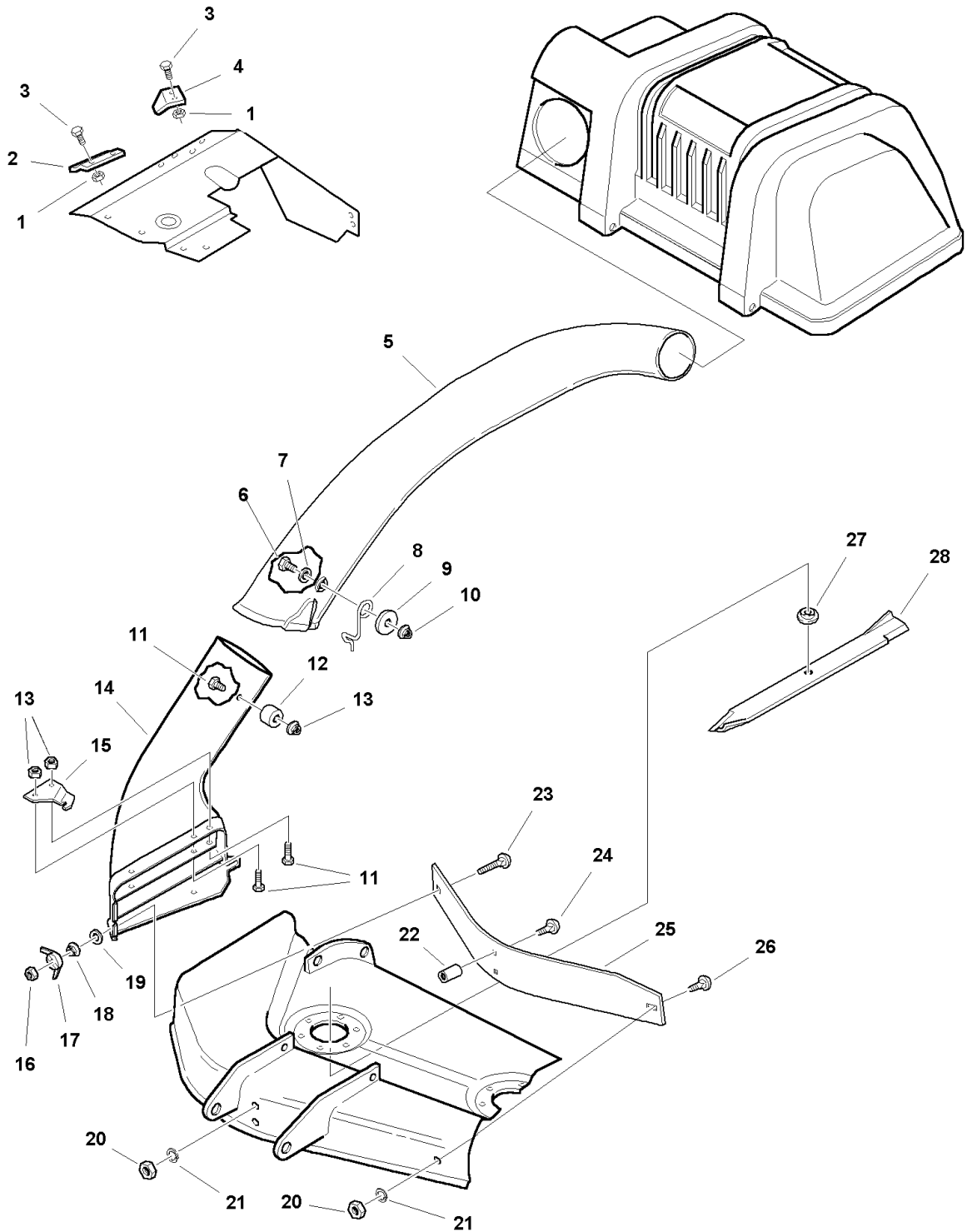

The above parts group applies to the following Mfg. Nos.:  
1692150 - Catcher

## Adapter, Blade & Tube Group

REF NO	PART NO.	QTY.	DESCRIPTION
1	1928919SM	4	NUT, Hex Washer Assembly, Hex, #10-32
2	1713286ASM	1	EXHAUST SHIELD, Front
3	1930531SM	4	SCREW, Truss Head, 10-32 x 1/2
4	1713287ASM	1	EXHAUST SHIELD, Rear
5	1703769SM	1	TUBE, Transfer
6	1960122SM	1	CAPSCREW, Hex Head, 5/16-18 x 3/4
7	1919326SM	1	WASHER, Flat, 5/16
8	1704603SM	1	LATCH, Tube
9	1960185SM	1	WASHER, Flat, 5/16
10	1935048SM	1	NUT, Flange Lock, 5/16-18
11	1960371SM	3	CAPSCREW, Hex Head, 5/16-18 x 3/4
12	1704341SM	1	WASHER, Special
13	1919438SM	3	LOCKNUT, Hex, 5/16-18
14	1709135SM	1	ADAPTER
15	1704355ASM	1	BRACKET, Attachment
16	1928698SM	1	NUT, Centerlock, 5/16-18
17	1679163SM	1	WING NUT ASSEMBLY 5/16
18	1927557SM	1	NUT, Hex Flange, 5/16-18
19	1679164ASM	1	CUP
20	1917372SM	3	NUT, Hex, 5/16-18
21	1917356SM	3	LOCKWASHER, 5/16
22	1674669SM	2	SPACER
23	1960273SM	1	CARRIAGE BOLT, 5/16-18 x 2-1/4
24	1931338SM	2	CARRIAGE BOLT, 5/16-18 x 1-3/4
25	1709112A	1	BAFFLE
26	1931332SM	1	CARRIAGE BOLT, 5/16-18 x 5/8
27	1705010SM	1	ADAPTER, Blade, High Lift
28	1706739ASM	1	BLADE, High Lift

### Footnotes

---

The above parts group applies to the following Mfg. Nos.:

1692150 - Catcher

## Cover & Bag Group - Twin

983952

NOTE: Unless noted otherwise,  
use the standard hardware torque  
specification chart.

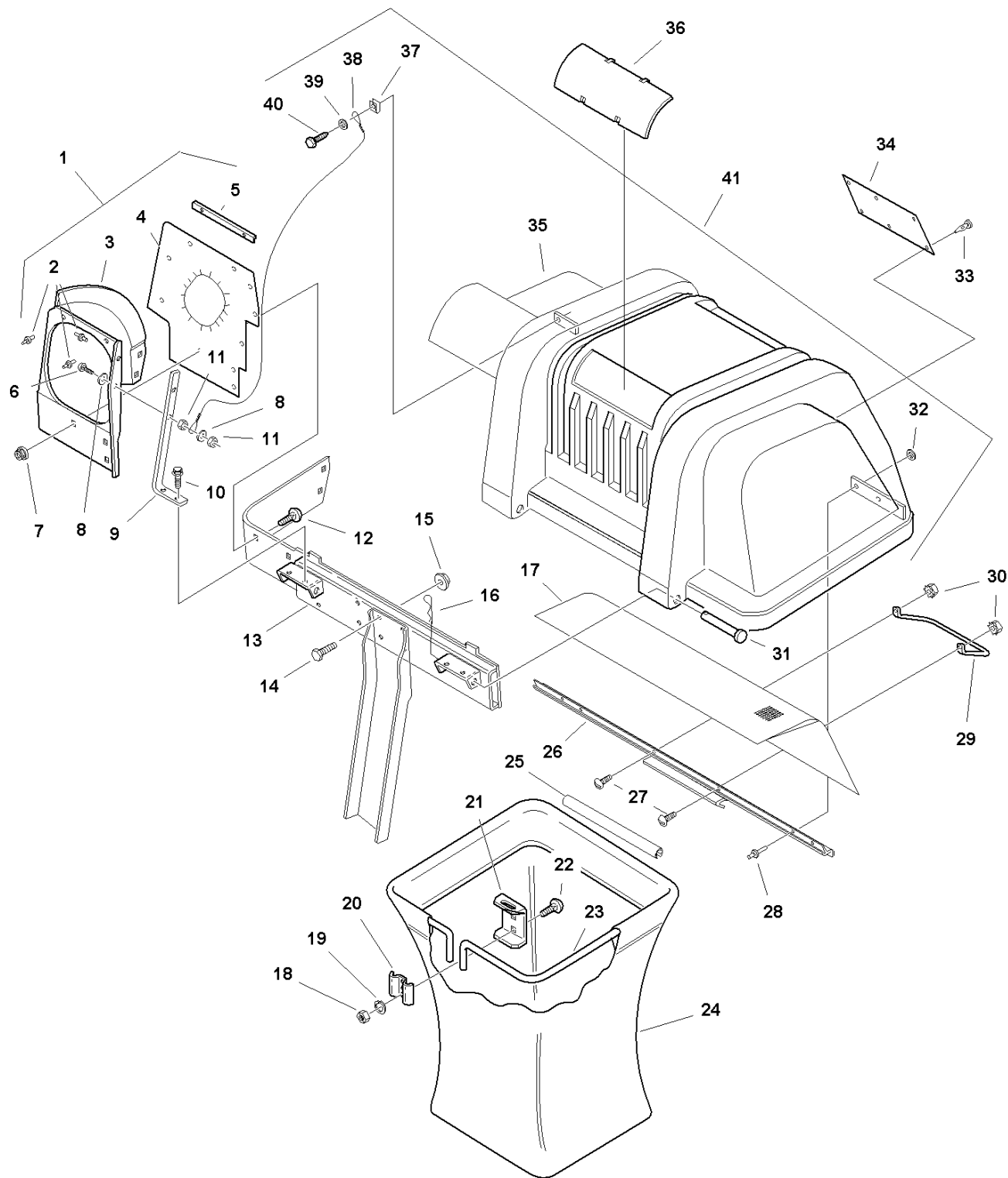

The above parts group applies to the following Mfg. Nos.:  
1692150 - Catcher

## Cover & Bag Group - Twin

REF NO	PART NO.	QTY.	DESCRIPTION
1	1704615SM	1	TUBE ASSEMBLY Support (Incl. Ref. Nos. 2, 3, 4, 5, 6, 8, 9 & 11)
2	1960381SM	7	RIVET, Pop
3	1704075SM	1	SUPPORT, Tube
4	1704135SM	1	SEAL, Cover
5	1704508SM	3	BRACKET, Seal
6	1960399SM	1	SCREW, Round Head, #8-32 x 7/8
7	1930642SM	5	LOCKNUT, Flange, 1/4-20
8	1960096SM	2	WASHER
9	1704507SM	1	STRAP, Tube Support
10	1929000SM	2	SCREW, Taptite, 1/4-20 x 3/8
11	1960077SM	2	NUT, Hex, Lock, #8-32
12	1960252SM	5	CARRIAGE BOLT, 1/4-20 x 5/8
13	1727129ASM	1	CROSS ASSEMBLY
13	1727129ASM	1	CROSS ASSEMBLY
14	1921966SM	4	CAPSCREW, Hex Head, 3/8-16 x 7/8
15	1928352SM	4	NUT, Hex, Whizlock, 3/8-16
16	1960221SM	2	CLIP, Hairpin
17	1703700SM	1	SCREEN
18	1917372SM	4	NUT, Hex, 5/16-18
19	1917356SM	4	LOCKWASHER, 5/16
20	1672023ASM	2	CLAMP
21	1703807ASM	2	HANGER
22	1931333SM	4	CARRIAGE BOLT, 5/16-18 x 3/4
23	1703855ASM	2	HOOP, Bag
24	1703764SM	2	BAG, Grass
25	1675707SM	2	TUBE CLIP, Grass Bag
26	1704057SM	1	SEAL, Clip
27	1930531SM	2	SCREW, Truss Head, #10-32 x 1/2
28	1675043SM	4	RIVET, Pop
29	1703853SM	1	HANDLE, Latch
30	1928919SM	2	NUT, Hex, #10-32
31	2860367SM	2	PIN, Round Head
32	1910531SM	4	WASHER
33	1667248SM	6	CLIP, Canoe
34	1732820SM	1	DECAL, Safety
35	1704056SM	1	COVER
36	1704180SM	2	WINDOW
37	1933886SM	1	NUT, Speed
38	1705876SM	1	CABLE, Double Loop
39	1921319SM	1	WASHER, 1/4
40	1960400SM	1	SCREW, Self-tapping, #10-12 x 5/8
41	1704056SM	1	COVER ASSEMBLY (Incl. Ref. Nos. 17, 26, 28, 32, 37, 38, 39 & 40)

### Footnotes

The above parts group applies to the following Mfg. Nos.:

1692150 - Catcher

## Hitch Group

984491

NOTE: Unless noted otherwise,  
use the standard hardware torque  
specification chart.

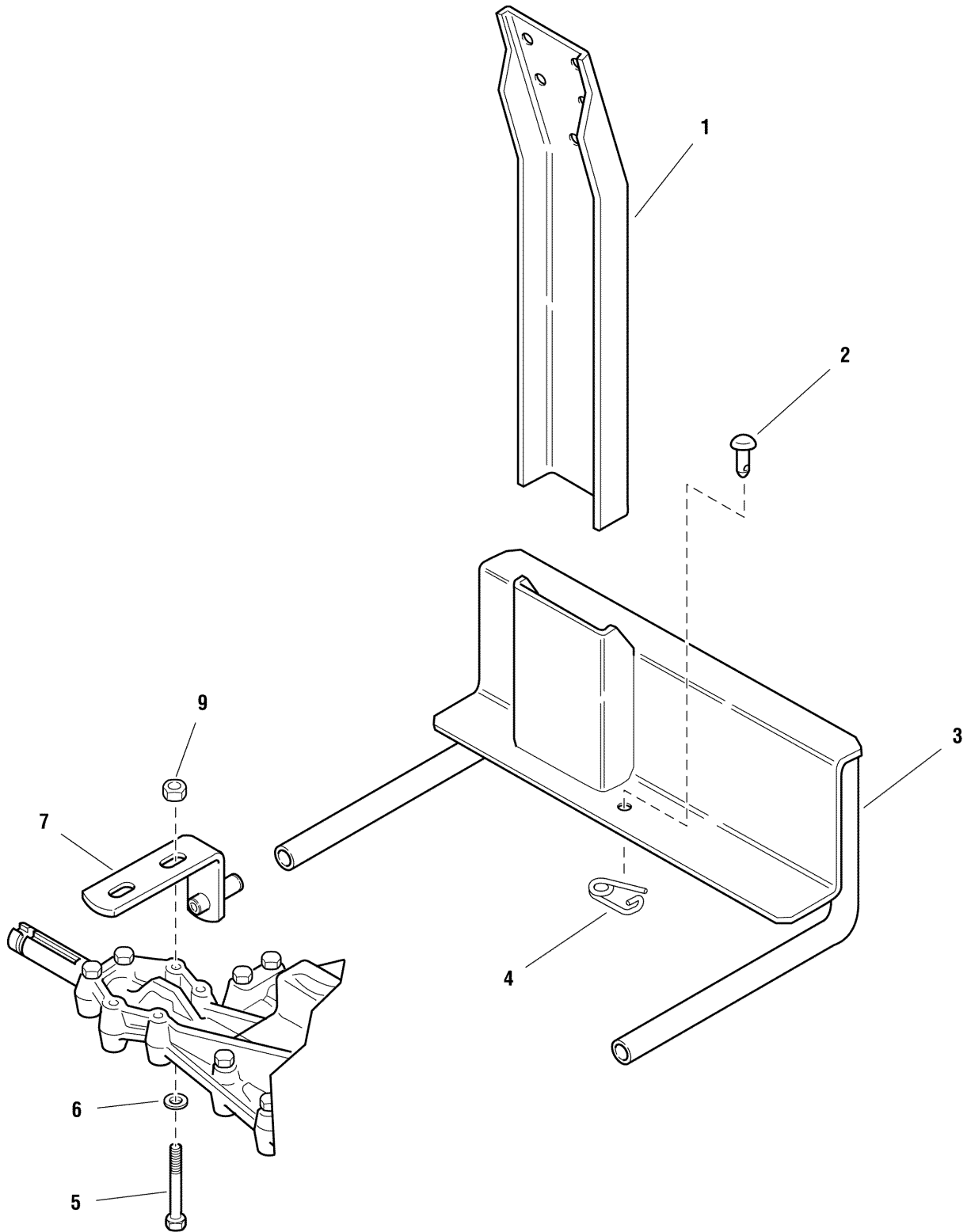

The above parts group applies to the following Mfg. Nos.:

1692150 - Catcher



## **Hitch Group**

---

<b>REF NO</b>	<b>PART NO.</b>	<b>QTY.</b>	<b>DESCRIPTION</b>
1	1709111ASM	1	SUPPORT, Catcher
2	2102004SM	1	PIN, Round Head, Drilled
3	1709022ASM	1	SUPPORT ASSEMBLY
4	2176012SM	1	CLIP, Pin, Safety
5	1960590SM	4	CAPSCREW, Hex Head, 5/16-18 x 3
6	1919326SM	8	WASHER, Plain 5/16
7	1709026ASM	2	ANCHOR ASSEMBLY, Older Models
7	1726975ASM	2	ANCHOR ASSEMBLY, Newer Models
9	1935048SM	4	NUT, Hex Flange Two-Way Lock 5/16-18

### **Footnotes**

---

**The above parts group applies to the following Mfg. Nos.:**

1692150 - Catcher



# Hardware Identification & Torque Specifications

## Common Hardware Types

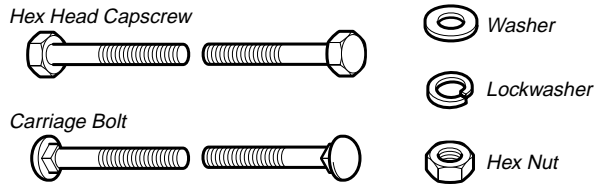

## Standard Hardware Sizing

When a washer or nut is identified as **1/2"**, this is the *Nominal size*, meaning the *inside diameter* is 1/2 inch; if a second number is present it represents the *threads per inch*

When bolt or capscrew is identified as **1/2 - 16 x 2"**, this means the *Nominal size*, or *body diameter* is 1/2 inch; the second number represents the *threads per inch* (16 in this example, and the final number is the *body length* of the bolt or screw (in this example 2 inches long).

**The guides and ruler furnished below are designed to help you select the appropriate hardware and tools.**

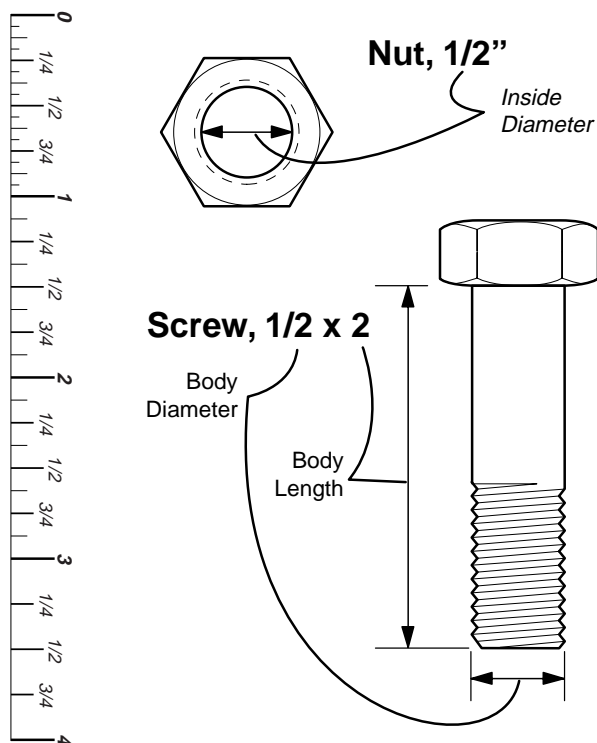

Torque Specification Chart						
FOR STANDARD MACHINE HARDWARE (Tolerance ± 20%)						
Hardware Grade	No Marks SAE Grade 2		SAE Grade 5		SAE Grade 8	
	in/lbs ft/lbs	Nm.	in/lbs ft/lbs	Nm.	in/lbs ft/lbs	Nm.
8-32	19	2.1	30	3.4	41	4.6
8-36	20	2.3	31	3.5	43	4.9
10-24	27	3.1	43	4.9	60	6.8
10-32	31	3.5	49	5.5	68	7.7
1/4-20	66	7.6	8	10.9	12	16.3
1/4-28	76	8.6	10	13.6	14	19.0
5/16-18	11	15.0	17	23.1	25	34.0
5/16-24	12	16.3	19	25.8	27	34.0
3/8-16	20	27.2	30	40.8	45	61.2
3/8-24	23	31.3	35	47.6	50	68.0
7/16-14	30	40.8	50	68.0	70	95.2
7/16-20	35	47.6	55	74.8	80	108.8
1/2-13	50	68.0	75	102.0	110	149.6
1/2-20	55	74.8	90	122.4	120	163.2
9/16-12	65	88.4	110	149.6	150	204.0
9/16-18	75	102.0	120	163.2	170	231.2
5/8-11	90	122.4	150	204.0	220	299.2
5/8-18	100	136	180	244.8	240	326.4
3/4-10	160	217.6	260	353.6	386	525.0
3/4-16	180	244.8	300	408.0	420	571.2
7/8-9	140	190.4	400	544.0	600	816.0
7/8-14	155	210.8	440	598.4	660	897.6
1-8	220	299.2	580	788.8	900	1,244.0
1-12	240	326.4	640	870.4	1,000	1,360.0

### NOTES

- These torque values are to be used for all hardware excluding: locknuts, self-tapping screws, thread forming screws, sheet metal screws and socket head setscrews.
- Recommended seating torque values for locknuts:
  - for prevailing torque locknuts - use 65% of grade 5 torques.
  - for flange whizlock nuts and screws - use 135% of grade 5 torques.
- Unless otherwise noted on assembly drawings, all torque values must meet this specification.

## Wrench & Fastener Size Guide



1/4" Bolt or Nut  
Wrench—7/16"

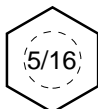

5/16" Bolt or Nut  
Wrench—1/2"

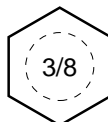

3/8" Bolt or Nut  
Wrench—9/16"

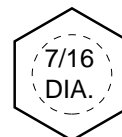

7/16" Bolt or Nut  
Wrench (Bolt)—5/8"  
Wrench (Nut)—11/16"

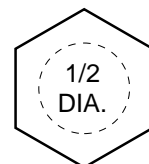

1/2" Bolt or Nut  
Wrench—3/4"

