

Snap-on®

MODEL #870011

CLIPPED HEAD FRAMING NAILER INSTRUCTION MANUAL

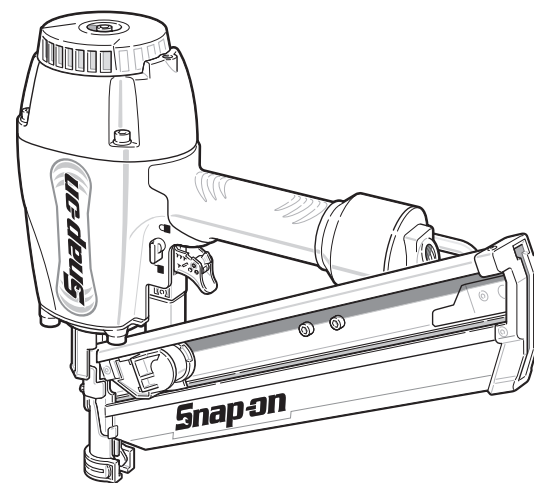

**FOR CUSTOMER SERVICE
PARA EL SERVICIO
PARA EL CONSUMIDOR
1-888-278-8092**

Printed in Taiwan

Snap-on®

SNAP-ON® IS A TRADEMARK LICENSED BY SNAP-ON® CORP., U.S.A., WHICH DOES NOT MANUFACTURE OR DISTRIBUTE THIS PRODUCT. CONSUMER INQUIRES SHOULD BE DIRECTED TO:

©COPYRIGHT 2007 ALLTRADE TOOLS, LLC.
1431 VIA PLATA
LONG BEACH, CA 90810-1462 USA

870011 – Clipped Head Air Nailer _Rev 10/4/07

THIS MANUAL CONTAINS IMPORTANT INFORMATION REGARDING SAFETY, OPERATION, MAINTENANCE AND STORAGE OF THIS PRODUCT. BEFORE USE, READ CAREFULLY AND UNDERSTAND ALL CAUTIONS, WARNINGS, INSTRUCTIONS AND PRODUCT LABELS. FAILURE TO DO SO COULD RESULT IN SERIOUS PERSONAL INJURY AND/OR PROPERTY DAMAGE.

IF YOU SHOULD HAVE ANY QUESTIONS OR EXPERIENCE A PROBLEM WITH YOUR SNAP-ON PRODUCT, DO NOT RETURN THIS PRODUCT TO THE STORE. PLEASE CALL OUR CUSTOMER SERVICE DEPARTMENT AT **1-888-278-8092**. BEFORE YOU CALL, HAVE THE FOLLOWING INFORMATION AVAILABLE: MODEL No., DATE PURCHASED AND STORE LOCATION.

TABLE OF CONTENTS

CONGRATULATIONS!	2
GENERAL SAFETY RULES	2
RECOGNIZE SAFETY SYMBOLS, WORDS AND LABELS	2-3
IMPORTANT INFORMATION ABOUT THIS MANUAL	4
SAFETY WARNINGS AND PRECAUTIONS	4-7
FUNCTIONAL DESCRIPTION	7-9
COMPONENT INSTALLATION	8-9
OPERATING THE CLIPPED HEAD NAILER	9-13
SELECT TRIGGER ACTUATION MODE	9-11
ADJUSTING DEPTH OF NAILING	11-12
USING THE HOOK	12
LOADING NAILS INTO THE AIR NAILER	12
USING THE NO-MAR NOSEPIECE	13
REQUIRED DAILY PREPARATION	13-14
USING THE AIR NAILER	14-16
LOCKING AND UNLOCKING THE TRIGGER	15
CHANGING DIRECTION OF EXHAUST AIR	15
CLEARING JAMS	16
MAINTENANCE	16-17
MANDATORY MAINTENANCE	18
TROUBLESHOOTING	18-19
PARTS DIAGRAM	20-21
PARTS LIST	22-25
SPECIFICATIONS	25
1 YEAR LIMITED WARRANTY	26-28

CONGRATULATIONS!

Thanks for choosing this product. Our aim is to provide you with the highest quality products, and we want you to be totally satisfied with your product and our Customer Service. If any help or advice is needed, please contact us at 1-888-278-8092. When properly cared for, this product will give you many years of satisfaction.

GENERAL SAFETY RULES

 **WARNING** **READ AND FOLLOW ALL INSTRUCTIONS.** Failure to follow all instructions in this manual may result in severe personal injury or death. Keep this manual and refer to it for Safety Instructions, Operating Procedures, and Warranty.

SAVE THESE INSTRUCTIONS FOR FUTURE REFERENCE.

RECOGNIZE SAFETY SYMBOLS, WORDS AND LABELS

The safety instructions provided in this manual are not intended to cover all possible conditions and practices that may occur when operating, maintaining and cleaning power tools.

Always use common sense and pay particular attention to all the **DANGER**, **WARNING**, **CAUTION** and **NOTE** statements of this manual.



This is the safety alert symbol. It is used to alert you to potential personal injury hazards. Obey all safety messages that follow this symbol to avoid possible injury or death.

DANGER

DANGER indicates an imminently hazardous situation which, if not avoided, will result in death or serious injury.

WARNING

WARNING indicates a potentially hazardous situation which, if not avoided, could result in death or serious injury.

CAUTION

CAUTION indicates a potentially hazardous situation which, if not avoided, may result in minor or moderate injury.

CAUTION

CAUTION used without the safety alert symbol indicates a potentially hazardous situation which, if not avoided, may result in property damage.

NOTE

NOTE provides additional information that is useful for proper use and maintenance of this tool. If a **NOTE** is indicated make sure it is fully understood.

In addition to **SAFETY ALERTS** listed above, there could also be numerous symbols alerting the operator that specific safety equipment is required to safely operate this tool. Learn these **SAFETY SYMBOLS** as well as the **SAFETY ALERTS** to prevent injury to the operator and to bystanders.



READ OPERATING INSTRUCTIONS: Read and understand tool labels, safety warnings and precautions in this manual before operating the tool. Failure to follow **WARNINGS** could result in serious injury or even death to the operator or bystanders.



WEAR APPROVED EYE PROTECTION: Safety glasses must conform to the requirements of American National Standards Institute (ANSI) Z87.1 and provide protection against flying particles from both front and side.



WEAR HEARING PROTECTORS: Hearing protectors should be worn to protect the ears from loud exhaust noise produced by the air tools.



USE ONLY CLEAN, DRY COMPRESSED AIR: Never use oxygen, combustible gases and any other bottled gas to operate air tools. Using these other sources can cause the air tool to explode.



NEVER POINT THE AIR NAILER AT YOURSELF OR OTHERS: Fasteners are under extreme pressure and can cause severe injury or even death if misused.



DO NOT EXCEED 120 psi (8.43 kg/cm²G). Using excessive pressure from the power source can cause the clipped head nailer to explode resulting in severe injury or even death to the operator or bystanders.

IMPORTANT INFORMATION ABOUT THIS MANUAL

Improper maintenance and operation are responsible for the majority of accidents involving clipped head nailers. The largest portion of these could be prevented by recognizing the basic safety rules and precautions. Most accidents can be avoided if the operator recognizes a potentially hazardous situation before it happens and by observing appropriate safety rules and procedures as outlined in this manual.

Basic safety precautions are outlined in the **SAFETY** portion of this manual and throughout text in this manual where a potential hazard might occur.

Hazards that **MUST** be avoided to prevent serious injury follow headers marked **DANGER** or **WARNING**. These same precautions are placed as labels on the tool itself.

NEVER use this nailer for applications that are **NOT** specified in this manual.

SAFETY WARNINGS AND PRECAUTIONS

⚠ DANGER

Do not operate clipped head nailer anywhere fastener may contact hidden electrical wiring. Contact with a "live" wire will make all metal parts of the clipped head nailer "live." This can result in severe electrical shock, severe burns or death to the operator. Contact a qualified electrical contractor to ensure a safe working environment exists.

Be aware of conduits or gas pipes. Striking a gas pipe could result in an explosion causing serious injuries or even death to the operator or bystanders.

Be aware of what is behind the work piece. A fastener could travel through the work piece and out the other side, striking a bystander resulting in serious injury or even death.

Do not operate the clipped head nailer in the presence of flammable liquids, such as gasoline, thinner, paint, or adhesives, gases or dust. Sparks created by the tool can cause flammable materials to ignite or explode. Failure to comply with this warning could result in serious injury or even death to the operator.

Keep bystanders, children and visitors away from area where clipped head nailer is being used. Distractions can result in severe injury or even death to anyone who inadvertently gets in the way of nailing operations.



Do not use oxygen, combustible or bottled gases (such as carbon dioxide or nitrogen) as a power source for the clipped head nailer.

Use only compressed air from a source as outlined in this manual. The tool will explode resulting in severe injury or even death to the operator and bystanders.

⚠ WARNING



Do not connect clipped head nailer to an air source capable of generating more than 200 psi (14.06 kg/cm² G). Over-pressurizing the clipped head nailer will result in bursting, abnormal operation or breakage of the tool. Use only clean, dry, regulated compressed air at levels specified on the tool. Failure to comply can cause severe injury or death to the operator or bystanders.

Do not attempt to fasten the trigger in the "ON" position. This could lead to an accidental discharge of the clipped head nailer. Do not operate the clipped head nailer if any portion of the tool's operating controls are inoperable, disconnected, altered in any way or not in proper working order. Failure to comply with this warning could result in serious injury or even death to the operator or other bystanders.



All air compressors must comply with the requirements of ANSI b19.3. Pressure regulators must be used to limit air pressure where air supply pressure exceeds the tool's rated operating pressure.

Do not carry the clipped head nailer with a finger on the trigger. This could lead to an accidental discharge of the clipped head nailer. Do not press the trigger of the clipped head nailer unless it is pressed firmly against the work piece. Do not point the clipped head nailer at yourself or in the direction of another person. Failure to comply with this warning could result in serious injury or even death to the operator or other bystanders.

Do not tamper with the work piece contact. The work piece contact prevents accidental discharge of the clipped head nailer and should never be removed or compromised in any way. Failure to comply with this warning could result in serious injury or even death to the operator or other bystanders.

Always disconnect air hose and remove any remaining nails:

1. When clipped head nailer is left unattended.
2. Before performing any maintenance or repair on the clipped head nailer.
3. Before attempting to clear a jam in the clipped head nailer.
4. Before moving the clipped head nailer to a new location.

Always check the overall condition of the clipped head nailer before using. Check for and tighten any loose screws. Ensure all safety systems are in working condition before using the clipped head nailer. The clipped head nailer must not operate if only the trigger is pulled or if only the work piece contact is pressed against the work piece. The clipped head nailer must only be used if both the trigger and work piece contact work at the same time.

⚠ WARNING



Always use hearing protection to protect your ears against hearing loss due to exhaust noise. Always wear proper safety glasses to prevent injuries to the eyes from fragments of the work piece, defective nails or other debris caused by using the clipped head nailer. All safety glasses must have side shields and should conform to the requirements of the American National Standards Institute (ANSI) z87.1. Failure to comply with this warning could lead to serious or permanent damage to the ears as well as serious damage or permanent blindness in the eyes.

Never carry the clipped head nailer by the air hose. A sudden disconnection of the air hose could cause the clipped head nailer to remain charged and an accidental firing could occur. Failure to comply with this warning could lead to serious injury to the operator or bystanders.

Always disconnect the power source and ensure the tool is not charged before loading fasteners. Failure to comply with this warning could cause severe injury or death to the operator, bystanders and severe damage to the clipped head nailer.

Never use a non-relieving air coupler with the clipped head nailer. Always use couplers that release any built-up charge in the clipped head nailer's firing mechanism. A non-relieving air coupler can allow the clipped head nailer to discharge a fastener while the tool is disconnected from the power source. Failure to comply with this warning can result in serious or permanent injury or even death to the operator or to bystanders.

Do not drive nails on top of other nails. Do not operate the clipped head nailer at too steep of an angle. Nails can ricochet. Failure to comply with this warning can result in serious injury or even death to the operator or bystanders.

Do not modify the clipped head nailer in any way. Unauthorized alterations can jeopardize safety in the tool's operation. Failure to follow this precaution can result in serious injury or even death to the operator or bystanders.

On rooftops and other high locations, always move forward as you use the clipped head nailer. You can easily lose your footing if moving backwards. When nailing against a perpendicular surface, nail from the top down. This causes less fatigue and reduces the chances of accidents.

Ensure the work area is sufficiently illuminated to operate power tools. The work area should be clear and free of litter.

⚠ WARNING

Thoroughly clean and maintain the clipped head nailer after every use. Lubricate moving parts to prevent rust and minimize friction-related wear. Wipe down the entire tool and remove all dust from the moving parts. Properly store the clipped head nailer in a suitable case to keep it ready for the next job.

All maintenance and repairs should be performed by an authorized repair facility. Call 1-888-278-8092 to obtain a list of repair facilities in your area or to make arrangements to return the tool for service.

FUNCTIONAL DESCRIPTION

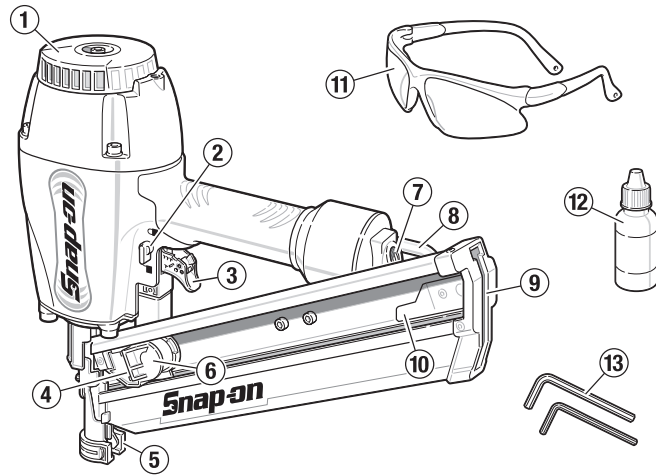

CONTROLS AND COMPONENTS:

- | | |
|---------------------|----------------------|
| 1. Exhaust Cover | 9. Magazine Inlet |
| 2. Trigger Lock | 10. Nail Stop |
| 3. Trigger | ACCESSORIES: |
| 4. Spring Lever | 11. Safety Glasses |
| 5. No-mar Nosepiece | 12. Lubricant |
| 6. Pusher | 13. Hex Wrenches (2) |
| 7. Air Inlet | |
| 8. Hanging Hook | |

COMPONENT INSTALLATION

⚠ WARNING

Never use a non-relieving air coupler with the clipped head nailer. Always use couplers that release any built-up charge in the clipped head nailer's firing mechanism. A non-relieving air coupler can allow the clipped head nailer to discharge a fastener while the tool is disconnected from the power source. Failure to comply with this warning can result in serious or permanent injury or even death to the operator or to bystanders.

When selecting an air compressor, it must comply with the requirements of the American National Safety Institute - ANSI B19.3.

Choose an air compressor that can supply more than the required air pressure to ensure optimum efficiency. Always use clean, dry compressed air with a maximum pressure of 200 psi. Use a pressure regulator and set the pressure between 70-120 PSIG (5.0- 8.5 kg/cm²G). Before each use, check the pressure regulator to ensure it is functioning within the proper pressure range.

⚠ WARNING

Using an air pressure of more than 120 psi can cause the clipped head nailer to malfunction or possibly explode causing severe injury or property damage.



SELECTING A PROPER AIR HOSE

Use an air hose with the largest diameter and shortest length possible to ensure continuous, efficient nailing operations. Using an air pressure of 70 psi (5.0 kg/cm²G), an air hose with an inside diameter of 1/4" (6.5 mm) or greater and a hose length of less than 6.6 ft (20 m), it is recommended that a 0.5 second interval be allowed between each nailing. Air supply hoses shall have a minimum working pressure of 150 psi (10.7 kg/cm²G) or 150% of the maximum pressure produced by the compressor or whichever is higher.

⚠ CAUTION

Low air output by the compressor or a longer hose with a smaller inside diameter in relation to the nailing frequency may decrease the driving capability of the air nailer.

SELECTING A QUICK DISCONNECT

1. Remove the plastic protective plug from the tool's air inlet.
2. Insert a 1/4" NPT male quick disconnect into the air inlet. Install the female portion to the air hose.

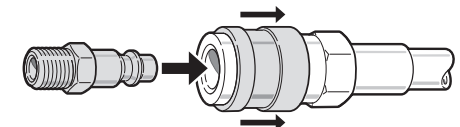

To improve the connection between the quick disconnect and air nailer, and to help prevent oxidation, apply PTFE tape or joint compound to the connector threads before insertion.

3. Snap the air hose onto the quick disconnect on the air nailer. Check for air leaks.

LUBRICATION

To ensure maximum performance, it is recommended to install an air set (oiler, regulator, and air filter) as close as possible to the air nailer. Adjust the oiler so that approximately one drop of oil will be released for every 50 nails.

If an air set is not used or is unavailable, oil the tool using pneumatic tool oil by placing 2 or 3 drops into the air inlet. This should be done before and after use. For proper lubrication, the tool must be fired several times after the oil is introduced to the filter.

OPERATING THE CLIPPED HEAD NAILER

⚠ WARNING



Always use hearing protection to protect your ears against hearing loss due to exhaust noise. Always wear proper safety glasses to prevent injuries to the eyes from fragments of the work piece, defective nails or other debris caused by using the clipped head nailer. All safety glasses must have side shields and should conform to the requirements of the American National Standards Institute (ANSI) z87.1. Failure to comply with this warning could lead to serious or permanent damage to the ears as well as serious damage or permanent blindness in the eyes.

Always disconnect the air hose before making adjustments or checking the functionality of the air nailer.

SELECT TRIGGER ACTUATION MODE

The clipped head nailer is equipped with a selectable trigger. This allows the selection of **Single Sequential Actuation Mode** or **Contact Actuation Mode**.

OPERATION IN SINGLE SEQUENTIAL ACTUATION MODE

To select the Single Sequential Actuation Mode (see Figure 1):

1. Press and hold the red Actuation Selector embedded in the trigger.
2. Rotate Actuation Selector down to the Single Sequential Actuation (T).
3. Release Actuation Selector, ensuring locking tab is fully seated in the slot.

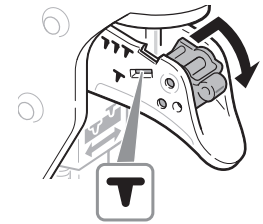

Figure 1

⚠ CAUTION

Ensure selector has locked into position. Ensure actuation process is fully understood before attempting to use clipped head nailer.

TO USE THE CLIPPED HEAD NAILER IN SINGLE SEQUENTIAL ACTUATION MODE:

1. Firmly grip clipped head nailer handle.
2. Position clipped head nailer work piece contact on work piece surface.
3. Push clipped head nailer against work piece compressing work piece contact.
4. Pull trigger on clipped head nailer to drive nail. The clipped head nailer will recoil away from the work piece as nail is driven.
5. Remove finger from trigger and lift clipped head nailer away from surface of work piece.

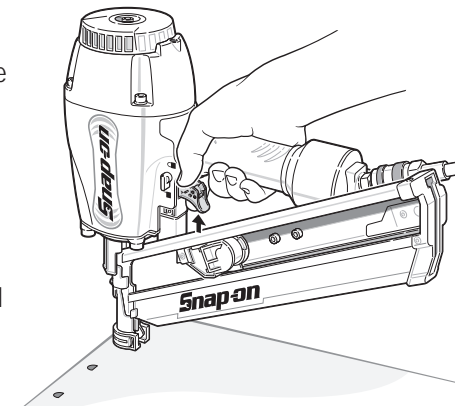

OPERATION IN CONTACT ACTUATION MODE

⚠ WARNING

When using contact actuation mode, be careful of unintentional double fires resulting from tool recoil. Unwanted fasteners may be driven if the work piece contact is allowed to accidentally re-contact the work piece.

To select Contact Sequential Actuation Mode (see Figure 2):

1. Press and hold Actuation Selector embedded in the trigger.
2. Rotate Actuation Selector up to the Contact Sequential Actuation (TTT).
3. Release Actuation Selector, ensuring locking tab is fully seated in the slot.

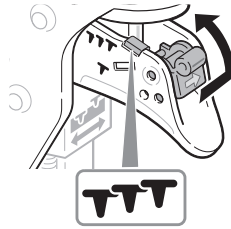

Figure 2

CAUTION

Ensure selector has locked into position. Ensure actuation process is fully understood before attempting to use clipped head nailer.

TO USE THE CLIPPED HEAD NAILER IN CONTACT ACTUATION MODE:

1. Firmly grip clipped head nailer handle.
2. Pull and hold the clipped head nailer trigger.
3. Push clipped head nailer against work piece compressing work piece contact.
4. The clipped head nailer will drive nail upon contact. The clipped head nailer will recoil away from the work piece as nail is driven.

ADJUSTING DEPTH OF NAILING

WARNING

Be aware of material thickness when using nailer. A protruding nail may cause injury.

Adjust the depth of nailing by loosening the two hex nuts (figure 3). Move nosepiece down for a shallower nail depth or up for a deeper nail depth. Once nosepiece is adjusted, tighten hex screws. To increase the depth of the nails when the nosepiece is already set to its lowest setting, increase the air pressure. To decrease the depth of nails when the nosepiece is already set to its highest setting, decrease the air pressure.

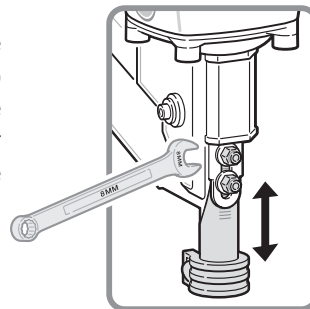

Figure 3

WARNING

Always disconnect the clipped head nailer before making any adjustments to the nail depth setting.

USING THE HOOK

WARNING

Always disconnect the air hose before hanging the clipped head nailer with the hook.

NEVER hook the clipped head nailer in a high location or on an unstable platform.

LOADING NAILS INTO THE AIR NAILER

WARNING

Always disconnect the air hose from the clipped head nailer before adding or removing nails.

NEVER use deformed nails or nail strip. Failure to observe this precaution can result in poor nail feeding and/or jams in the feeding mechanism.

To load nails in clipped head nailer, slide nails through magazine inlet in back of magazine. Pull pusher back until it is behind nail strip, then release pusher.

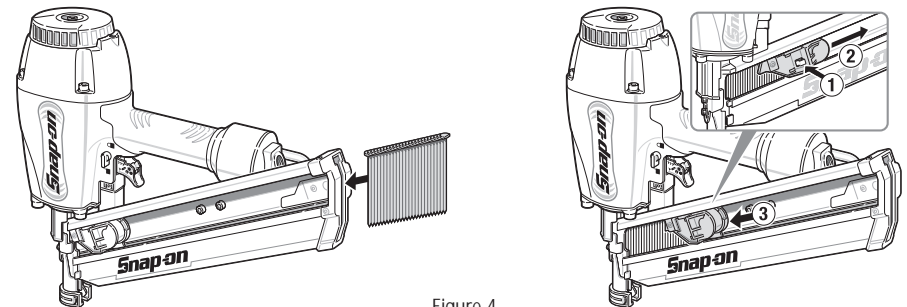

Figure 4

To remove nails from clipped head nailer, pull slightly back on pusher and depress spring lever (Figure 4). Allow pusher to pass over nail strip and move strip to back of magazine. Depress the nail stop allowing nail strip to be removed from magazine inlet.

USING THE NO-MAR NOSEPIECE

⚠ WARNING Always disconnect the air hose before attaching the no-mar nosepiece.

In order to prevent the surface of the work piece from being scratched or damaged, use the no-mar nosepiece. Install no-mar nosepiece by pressing it into place on the nose frame. See Figure 5.

Store the no-mar nosepiece in place when not being used.

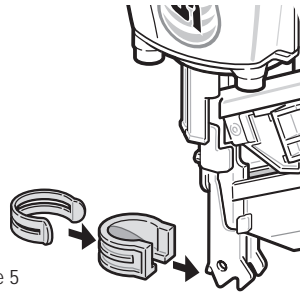

Figure 5

⚠ WARNING Never use a non-relieving air coupler with the clipped head nailer. Always use couplers that release any built-up charge in the clipped head nailer's firing mechanism. A non-relieving air coupler can allow the clipped head nailer to discharge a fastener while the tool is disconnected from the power source. Failure to comply with this warning can result in serious or permanent injury or even death to the operator or to bystanders.

When the air hose is disconnected, the pressure reservoir in the air nailer will discharge removing any built-up air inside the tool.

REQUIRED DAILY PREPARATION

The following steps should be performed on a daily basis to ensure the clipped head nailer is operating correctly:

1. Disconnect air supply from nailer and remove fastener strip.
2. Check all screws, nuts and pins and ensure all are tight.
3. Press the pusher release button and slide back the pusher assembly (Overriding the dry fire lockout). Press the work piece contact against a work piece ensuring smooth movement.
4. With work piece contact against the work piece, pull trigger. The trigger must operate smoothly.
5. Connect air supply and set regulator for 70 psi. DO NOT load a fastener strip.

6. Select Single Sequential Actuation Operation. Check for leaks. Without pulling the trigger, press the work piece contact against the work piece. The tool MUST NOT operate. Holding the tool away from the work piece, pull trigger and hold for 5 seconds. The tool MUST NOT operate. Repeat steps several times. Without pulling trigger, press nailer against work piece and pull trigger. The tool MUST operate. Release trigger. Driver MUST move up.
7. Select Contact Actuation Operation. Holding nailer away from work piece, pull trigger. The tool MUST NOT operate. While still pulling trigger, press the nailer against work piece. The tool MUST operate.
8. If Steps 1 through 7 function properly, prepare the tool for use. Select operation mode and load fasteners.
9. Set the required depth of drive.
10. Repeat these steps daily. Test again if the nailer is dropped, jammed, etc.

USING THE AIR NAILER

To drive a nail, place the work piece contact of the clipped head nailer against the work piece and pull the trigger. See Figure 6.

To avoid any unexpected nailings, perform the operation as follows:

1. Avoid placing the work piece contact against the work piece with excessive force.
2. Pull the trigger fully and hold it in the fired position for 1 to 2 seconds before releasing the trigger. This will give the clipped head nailer time to completely expend the previous nail and build enough pressure for the next nail.

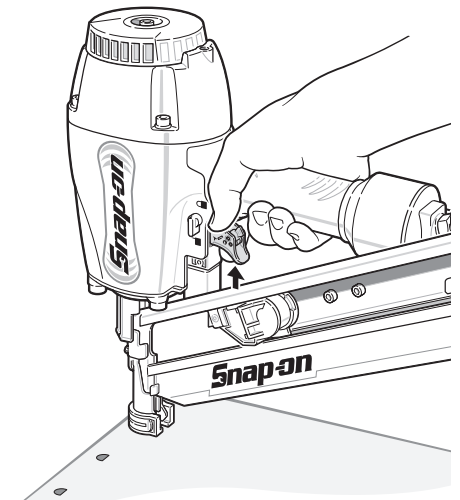

Figure 6

⚠ WARNING DO NOT hold the trigger in a half-pulled position. This could cause an unexpected nailing to occur if the work piece contact is permitted to re-contact the work piece. Failure to comply could result in damage to work piece.

LOCKING AND UNLOCKING THE TRIGGER

⚠ WARNING Always move lever to the locked position immediately after using the nailer to prevent unintended firing of fastener.

The clipped head nailer is equipped with a trigger lock to prevent operation of the tool when not actively being used. To lock trigger, move trigger lock lever up to the locked position. To unlock trigger in preparation for use, move the trigger lock lever down to the unlocked position (Figure 7).

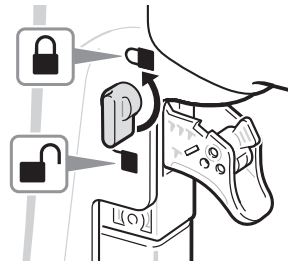

Figure 7

CHANGING DIRECTION OF EXHAUST AIR

The direction of exhaust air on the air nailer can be directed 360° degrees by placing hand on exhaust cover and turning. See Figure 8.

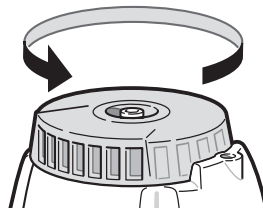

Figure 8

CLEARING JAMS

Typically, jams are caused when a fastener or a fastener fragment becomes wedged between the driver blade and nail guide. Using the wrong fastener can also cause jams.

TO CLEAR A JAM:

1. Disconnect the air supply and remove the fastener strip. Leave the pusher assembly open.
2. Loosen hex screws from back of magazine and pull magazine back. See Figure 9.

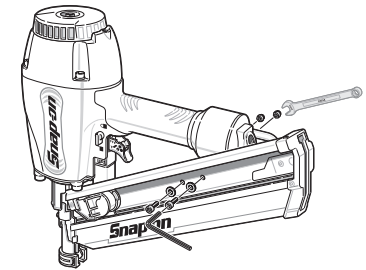

Figure 9

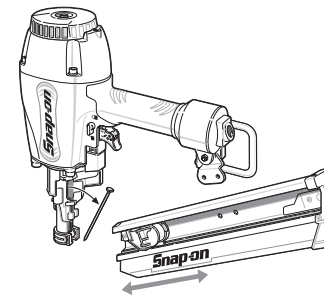

Figure 10

3. Remove jammed fastener.
4. Slide magazine back in position and refasten hex screws (Figure 10).

MAINTENANCE

STORAGE OF NAILS

Always handle nail strips and their box very carefully. If the nail strips have been mis-handled, they may be out of shape or have breaks in the connecting strips. This will cause the nails to feed poorly and possibly result in misfiring or jams in the air nailer. Avoid storing nails in a very humid or hot environment or place in direct sunlight.

OVERALL MAINTENANCE OF AIR NAILER

⚠ WARNING Always disconnect the air hose from clipped head nailer before attempting any type of maintenance or visual inspection of tool.

Always visually inspect clipped head nailer before every use. Check on the overall condition and for any loose screws. Tighten any screws that have come loose. See Figure 11.

Visually inspect the work piece contact and trigger to ensure there is free movement. See Figure 12.

When the tool is not going to be used for an extended period, wipe off all dust and debris that have collected on it. Tighten all loose screws. Lubricate the firing mechanism with pneumatic tool oil. See page 9 for Lubrication.

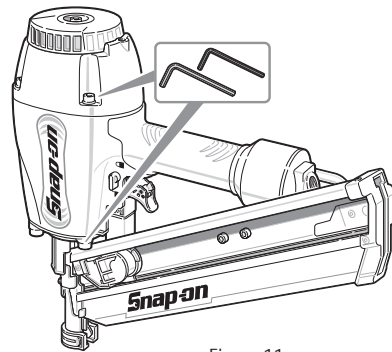

Figure 11

Store the clipped head nailer in a safe location or in suitable carrying case. It is recommended that the air nailer be secured in a locked location to prevent unauthorized usage.

Avoid exposure to direct sunlight and/or locations with high humidity and heat.

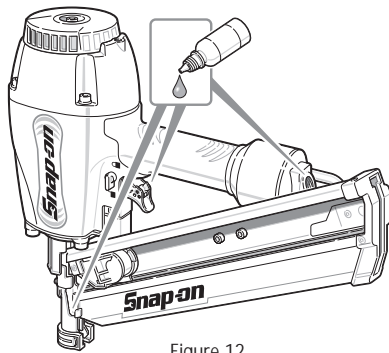

Figure 12

WARNING Remove the clipped head nailer from use and schedule to have it repaired at an authorized repair facility if the work piece contact is binding or not moving freely. Do not attempt to repair the clipped head nailer. Failure to comply can result in malfunction of the tool and severe injury to the operator or any bystanders.

MANDATORY MAINTENANCE

WARNING All maintenance and repairs should be performed by an authorized repair facility. Call 1-888-278-8092 to obtain a list of repair facilities in your area or to make arrangements to return the tool for service.

ACTION	REASON	OPERATION
Clean magazine and feeder mechanism.	Prevents clipped head nailer from jamming.	Use compressed air and clean daily.
Inspect and ensure work piece contact operates properly.	Ensures operator safety and keeps clipped head nailer working efficiently.	Use compressed air and clean daily.
Lubricate clipped head nailer after every use using pneumatic tool oil.	Extends life of clipped head nailer.	Apply 2 – 3 drops of pneumatic tool oil to clipped head nailer air inlet after every use.

TROUBLESHOOTING

Most minor problems can be resolved quickly and easily using the troubleshooting table below. For problems that cannot be solved, contact Customer Service (toll free) at 1-888-278-8092.

PROBLEM	POSSIBLE CAUSE	SOLUTION
Nailer operates, but no nail is driven.	Check for jammed nail. Ribbon spring weakened or damaged. Inspect nail feeder mechanism. Ensure correct nails are being used.	Clear jammed nail. Replace ribbon spring. Clean and lubricate nail feeder. Use ONLY recommended nails.

PROBLEM	POSSIBLE CAUSE	SOLUTION
Weak drive. Slow to cycle between nailings.	Ensure proper air pressure is being used. Inspect for worn driver blade. Inspect piston O-ring for wear or damage.	Increase air pressure, Do not exceed 120 psig (8.3 bars, 8.5 kg/cm ²) Contact Customer Service.
Nails driven too deep.	Check air pressure.	Reduce air pressure.
Clipped head nailer feeds intermittently or skips nails.	Ensure correct nails are being used. Inspect nail feeder mechanism. Ribbon spring weakened or damaged. Piston O-ring damaged or worn Nail feeder worn or damaged.	Use ONLY recommended nails. Clean and lubricate nail feeder. Replace ribbon spring. Use recommended pneumatic tool oil. Contact Customer Service. Replace nail feeder.
Nails jam or driven nail is bent.	Ensure correct nails are being used. Inspect for worn driver blade. Nail feeder worn or damaged.	Use ONLY recommended nails. Contact Customer Service. Replace nail feeder.
Drives nails properly during normal nailing operations, but fails to drive nails fully at faster operating speeds.	Check inside diameter of air hose.	Switch to air hose with larger inside diameter.

PARTS DIAGRAM

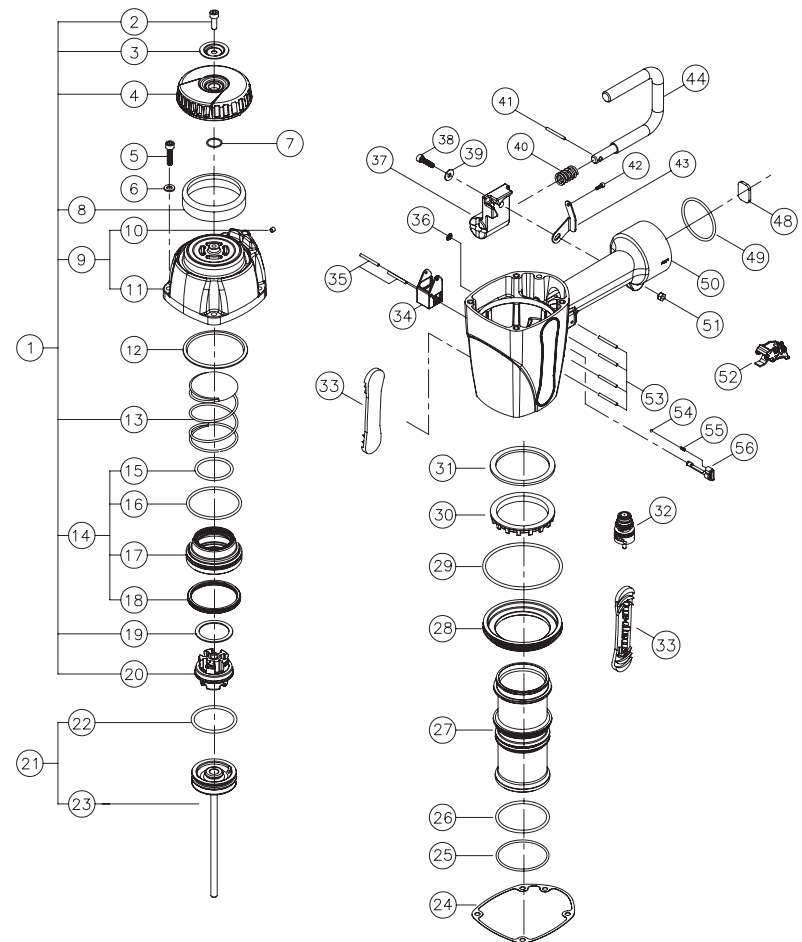

PARTS DIAGRAM

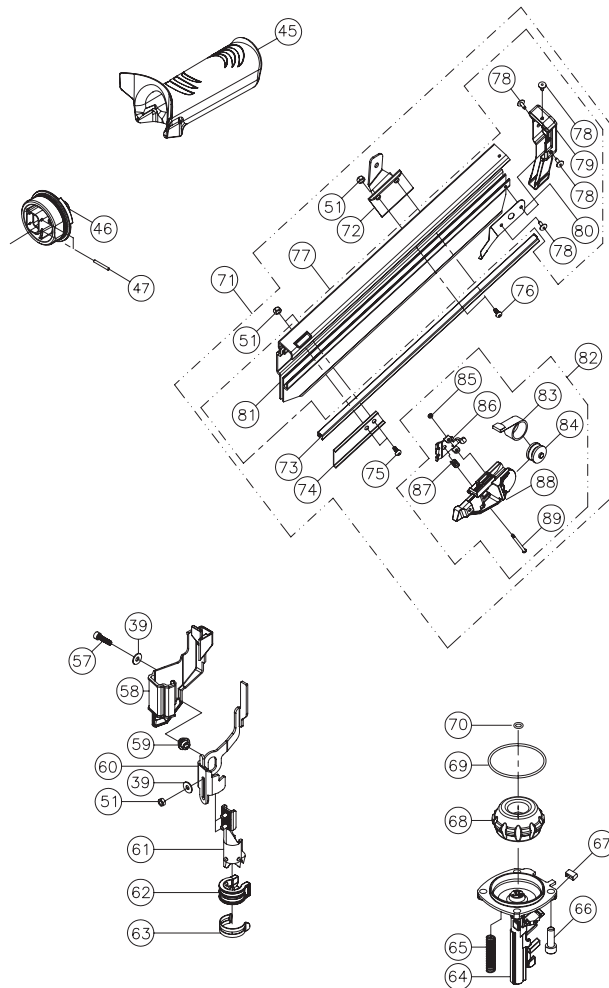

PARTS LIST

ITEM NO.	PART NO.	DESCRIPTION
1	K0300-4011	Top Cap Set
2	A0000-0421	Nylon Screw M6*18
3	A0005-1071	Washer
4	A0304-0521	Exhaust Cover
5	A0000-0171	Screw M6*30
6	A0005-0541	Washer 12.5*1.6T
7	A0200-0811	O-Ring 11.8*1.5
8	A0203-0111	Muffler
9	K0300-4021	Top Cap & Screw Set
10	A0003-0331	Screw
11	A0301-1641	Cap, Top
12	A0317-0001	Wear Ring
13	A0100-1971	Spring
14	K0300-2741	Firing Valve Set
15	A0200-2612	O-Ring 39.4*3.2
16	A0200-3211	O-Ring 59.4*3.1
17	A0308-0491	Firing Valve
18	A0313-0281	Seal Firing Valve
19	A0005-0551	Washer Support
20	A0313-0121	Piston Retainer
21	K0600-3991	Piston Unit
22	A0200-1962	O-Ring 47.3*3.5
23	K0600-3981	Piston Set
24	A0205-0411	Gasket

ITEM NO.	PART NO.	DESCRIPTION
25	A0200-3221	O-Ring 58*2.5
26	A0200-1952	O-Ring 57.5*3.3
27	A0303-0811	Cylinder
28	A0800-0781	Spacer
29	A0200-2002	O-Ring 85*3.5
30	A0311-0351	Sleeve Hold Down
31	A0305-0131	Collar
32	K0500-0901	Trigger Valve Set
33	A0313-0651	Main Body Bumper
34	A0712-1181	Release Guide
35	A0011-0091	Spring Pin 3*20
36	A0005-0131	E-Ring 4
37	A0719-1211	Hook Fixer
38	A0000-1791	Nylon Screw M5*28
39	A0005-0531	Washer 14*1T
40	A0100-1051	Outlet Spring
41	A0011-0071	Spring Pin 3*16
42	A0000-0351	Screw M3*8
43	A0706-1711	Support
44	A0316-0341	Hook
45	A0204-1671	Grip
46	A0306-1201	Tail Cover
47	A0011-0161	Spring Pin 3*24
48	A0203-0191	Filter
49	A0200-3011	O-Ring 50*3

ITEM NO.	PART NO.	DESCRIPTION
50	A0401-2031	Body
51	A0004-0021	Nylon Nut M5
52	K0500-1501	Trigger Set
53	A0011-0201	Spring Pin 3*30
54	A0009-0011	Steel Ball
55	A0100-1961	Spring
56	B0000-0351	Lock Pin Set
57	A0000-0411	Nylon Screw M5*20
58	A0712-1191	Catch Cover
59	A0201-0122	Bushing
60	A0711-2021	Lower Safety B
61	A0711-2001	Lower Safety A
62	A0204-1081	No Mar Pad
63	A0106-0101	Spring Clip
64	A0713-0881	Guide Body
65	A0100-2151	Spring
66	A0000-0891	Screw M8*25
67	A0713-0341	Feeder Shoe Stop
68	A0309-0731	Bumper
69	A0200-0791	O-Ring 63.9*2.5
70	A0200-1101	O-Ring 7*2
71	K1100-2421	Magazine Set
72	A0706-1371	Support
73	A0708-0392	Steel Bar
74	A0713-0352	Insert

ITEM NO.	PART NO.	DESCRIPTION
75	A0000-0681	BHSC Screw M5*10
76	A0000-0061	Screw M5*12
77	K0700-4741	Magazine Set
78	A0003-0221	Rivet
79	A0718-0561	Magazine Cover
80	A0105-0191	Nail Detainer
81	A0701-2431	Rail Magazine
82	K0700-4771	Pusher Assembly
83	A0102-0071	Spring
84	A0703-0151	Roller, Negator Spring
85	A0005-0311	Pin Retainer 5.5*2
86	A0707-1741	Feeder Clip
87	A0100-1081	Spring
88	K0700-4751	Pusher Set
89	A0006-1351	Pin

SPECIFICATIONS

MODEL NUMBER	870011
AIR PRESSURE	70-120 PSIG (5.0- 8.5 kg/cm ² G)
NAIL LENGTH	2" (50.8 mm) - 3 1/2" (88.9 mm)
COLLATION ANGLE	30-34°
MINIMUM HOSE DIAMETER	1/4" (6.5 mm)
NET WEIGHT	7.2 LBS. (3.2 KG)

1 YEAR LIMITED WARRANTY

Express and Exclusive Limited Warranty to Original Retail Buyer

Alltrade Tools LLC (hereinafter "Alltrade") expressly warrants to the original retail purchaser of the accompanying SNAP-ON™ portable air tool and no one else all parts of the product (except those parts referred to below which are specifically excluded from such warranty (see Exclusions) to be free from defects in materials and workmanship for a period of one year from the original date of purchase.

The date of purchase shall be the date of shipment to the original purchaser, or the date the original purchaser took possession, custody, or control of the product, whichever occurred first. This warranty shall be null and void if the product or any component thereof is modified or altered. This warranty does not apply to any other product and/or component thereof manufactured or distributed by Alltrade, and does not apply to products and/or components thereof designed, manufactured and/or assembled by others, for which Alltrade makes no warranties whatsoever. **THERE ARE NO WARRANTIES, WHICH EXTEND BEYOND THE DESCRIPTION ON THE FACE HEREOF.**

WARRANTY PERFORMANCE

By purchasing this product, purchaser expressly acknowledges and agrees that their sole and exclusive remedy under this warranty shall be strictly limited to the repair or replacement of any covered nonconforming items or parts thereof provided that any such nonconforming item and/or part is promptly returned to an authorized Service Center within the applicable warranty period, with a written request by purchaser to repair and/or replace the nonconforming item and/or part. We recommend that you keep the original product packaging in the event you need to ship the unit. We suggest the package be insured against loss or in transit damage. When sending your product, include your name, address, phone number, e-mail address, dated proof of purchase (or copy) and a statement about the nature of the problem. Warranty coverage is conditioned upon purchaser furnishing Alltrade with adequate written proof that they are the original purchaser and of the original purchase date. Parts returned, freight prepaid and insured, will be inspected and, at Alltrade's option, repaired and/or replaced free of charge if it is found to be defective and subject to warranty. Alltrade retains the sole discretion to determine whether any item or part is nonconforming and, if so, whether the item and/or part will be repaired and/or replaced. If the unit is repaired, new or reconditioned replacement parts may be used. If Alltrade chooses to replace the product, it may replace it with a new or reconditioned of the same or comparable design. The repaired or replaced unit will be warranted under the terms of the remainder of the one year warranty period; covered defective parts not subject to normal wear and tear or other exclusions will be repaired or replaced, at Alltrade's option. During the warranty period, Alltrade will be responsible for the return shipping charges. Alltrade's repair and/or replacement of any nonconforming item and/or part thereof shall constitute fulfillment of all obli-

gations to the purchaser. Alltrade shall not be responsible or liable for any expense, including freight charges, or repairs made outside Alltrade's facility or an Alltrade designated service, unless expressly agreed to by Alltrade in writing. Under no circumstances shall Alltrade bear any responsibility for loss of the unit, loss of time or rental, inconvenience, commercial loss, or consequential damages.

For the location of an Authorized Service Center nearest you, please call customer service at 1-888-278-8092.

EXCLUSIONS

Air nailers and staplers need periodic maintenance to remain in proper operating condition. Normal wear parts (o-rings and driver blades) shall be warranted to the original purchaser to be free from defects in materials and workmanship for a period of 90 days from the original date of purchase.

This warranty does not cover parts damaged due to normal wear, abnormal conditions, misapplication, misuse, abuse, accidents, operation, improper storage, or freight damage. Parts damaged or worn by operation in dusty environments are not warranted. Failure to follow recommended operating and maintenance procedures also voids warranty.

DAMAGE TO THE PRODUCT RESULTING FROM TAMPERING, ACCIDENT, ABUSE, NEGLIGENCE, FAILURE TO FOLLOW INSTRUCTIONS, UNAUTHORIZED REPAIRS OR ALTERATIONS, DAMAGE WHILE IN TRANSIT TO OUR SERVICE FACILITY, USE OF UNAPPROVED OR IMPROPER ATTACHMENTS OR ACCESSORIES, OR OTHER CAUSES UNRELATED TO PROBLEMS WITH MATERIAL OR WORKMANSHIP ARE NOT COVERED BY THIS WARRANTY.

Alltrade will not be liable for the following: labor charges, loss or damage resulting from improper operation, maintenance or repairs made by other persons; pre-delivery services such as assembly, oil and lubricants, and adjustment; maintenance services that are normally required to maintain the product.

The use of other than genuine Snap-On™ Repair Parts will VOID the warranty.

WARRANTY DISCLAIMERS

EXCLUSION AND DISCLAIMER OF ALL OTHER EXPRESS WARRANTIES, GUARANTIES AND/OR REPRESENTATIONS, EXCEPT FOR THE LIMITED WARRANTY PROVIDED HEREIN, ALL OTHER EXPRESS WARRANTIES, GUARANTIES, AND/OR REPRESENTATIONS BY ALLTRADE AND OR ITS REPRESENTATIVE(S) REGARDING THE DESIGN, MANUFACTURE, PURCHASE, USE AND/OR OPERATION OF THE PRODUCT OR ANY COMPONENT THEREOF SOLD HEREUNDER, REGARDLESS OF WHETHER ANY SUCH WARRANTY, GUARANTY AND/OR REPRESENTATION, WRITTEN OR ORAL, ARISES BY OPERATION OF LAW AND/OR EQUITY AND/OR BY ANY ACT OR OMISSION OF ALLTRADE AND/OR ITS REPRESENTATIVE(S), OR THE BUYER, ARE HEREBY EXPRESSLY EXCLUDED AND DISCLAIMED BY ALLTRADE AND/OR ITS REPRESENTATIVES. PURCHASER KNOWINGLY AND WILLINGLY

WAIVES ANY AND ALL SUCH WARRANTIES AND RIGHTS, CLAIMS AND/OR CAUSE OF ACTION ARISING THEREFROM OR BASED THEREON. PURCHASER'S SOLE AND EXCLUSIVE REMEDY IS AS STATED ABOVE.

EXCLUSION AND DISCLAIMER OF ALL IMPLIED WARRANTIES, INCLUDING THE IMPLIED WARRANTIES OF MERCHANTABILITY AND FITNESS FOR A PARTICULAR PURPOSE. NO WARRANTY, ORAL OR WRITTEN, OTHER THAN THE WARRANTY LISTED HEREIN IS MADE WITH REGARD TO THIS PRODUCT. ALL WARRANTIES AND/OR IMPLIED WARRANTIES, GUARANTIES AND/OR REPRESENTATIONS BY ALLTRADE AND/OR ITS REPRESENTATIVE(S) REGARDING THE DESIGN, MANUFACTURE, PURCHASE, USE AND/OR OPERATION OF THE PRODUCT OR ANY COMPONENT THEREOF SOLD HEREUNDER, REGARDLESS OF WHETHER ANY SUCH WARRANTY, GUARANTY AND/OR REPRESENTATION, WRITTEN OR ORAL, ARISES BY OPERATION OF LAW AND/OR EQUITY AND/OR BY ANY ACT OR OMISSION OF ALLTRADE AND/OR ITS REPRESENTATIVES. PURCHASER KNOWINGLY AND WILLINGLY WAIVES ANY AND ALL SUCH WARRANTIES AND RIGHTS, CLAIMS AND/OR CAUSES OF ACTION ARISING THEREFROM OR BASED THEREON.

PURCHASER'S SOLE AND EXCLUSIVE REMEDY IS AS STATED ON PRECEDING PAGES.

LIMITATIONS OF LIABILITY

IN NO EVENT SHALL ALLTRADE AND/OR ITS REPRESENTATIVE(S) BE LIABLE FOR INDIRECT, INCIDENTAL, SPECIAL AND/OR CONSEQUENTIAL DAMAGES OF ANY KIND ARISING OUT OF OR RELATED TO, DIRECTLY OR INDIRECTLY, ANY BREACH OR PROVISION OF ANY AGREEMENT BETWEEN ALLTRADE AND/OR ITS REPRESENTATIVE(S) AND PURCHASER, AND WARRANTY HEREUNDER, AND/OR THE EXISTENCE, DESIGN, MANUFACTURE, PURCHASE, USE AND/OR OPERATION OF ANY ITEM(S) SOLD HEREUNDER EVEN IF ALLTRADE AND/OR ITS REPRESENTATIVE(S) HAS BEEN ADVISED OF THE POSSIBILITY OF ANY SUCH DAMAGES. IN NO EVENT, WHETHER BECAUSE OF A BREACH OF CONTRACT, WARRANTY, TORT (INCLUDING NEGLIGENCE) OR OTHERWISE, SHALL ALLTRADE'S AND/OR ITS REPRESENTATIVE (S) LIABILITY EXCEED THE PRICE OF THE PRODUCT. ALL LIABILITY CONNECTED WITH THE USE OF THIS PRODUCT SHALL TERMINATE UPON THE EXPIRATION OF THE WARRANTY PERIODS SPECIFIED ABOVE.

LIMITATIONS ON WARRANTY DISCLAIMERS

Some states do not allow limitations on how long an implied warranty lasts and some states do not allow the exclusion or limitation of the incidental or consequential damages, so part or all of the above limitations or exclusions may not apply to you. This warranty gives you specific legal rights, and you may also have other rights, which vary from state to state.

If your product is not covered by this warranty, please call our Customer Service Department at 1-888-278-8092 for general repair information, and charges and the location of your nearest authorized service facility.