

- IT** Manuale d'uso del cassetto scaldastoviglie
- FR** Le guide d'utilisation de votre tiroir chauffant
- GB** Guide for using your warming drawer
- NL** Handleiding voor uw verwarmingslade
- DE** Benutzerhandbuch für Ihre Wärmeschublade
- ES** Guía de uso de su cajón calentaplatos
- PT** Manual de utilização do aquecedor de loiça
- SV** Användarmanual för din värmelåda



CTSC21X

Protection of the environment	21
Editorial	22
Description of warming drawer	23
Safety tips	24
Installation	25
Encasement	26
Using your warming drawer	27
Cleaning and maintenance	30

PROTECTION OF THE ENVIRONMENT :

The packaging materials used for this appliance can be recycled. Take part in recycling and help protect the environment by discarding them in the appropriate waste bins provided by the municipal authorities.



The symbol  on the product or on its packaging indicates that this product may not be treated as household waste. Instead it shall be handed over to the applicable collection point for the recycling of electrical and electronic equipment. By ensuring this product is disposed of correctly, you will help prevent potential negative consequences for the environment and human health, which could otherwise be caused by inappropriate waste handling of this product.

For more detailed information about recycling of this product, please contact your local city office, your household waste disposal service or the shop where you purchased the product.

Editorial

Dear Client,

You have just acquired a SMEG warming drawer; thank you for your purchase.

Our research teams have designed a new generation of appliances with you in mind. Their quality, design and state-of-the-art technology incorporate our unique know-how that makes these products exceptional.

Your new SMEG warming drawer will be an attractive addition to your kitchen, combining ease of use with effective performance for preheating your tableware.

SMEG products include a wide range of ovens, microwave ovens, glass-ceramic cook tops, vented hoods, built-in dishwashers, washing machines and refrigerators that you can match to your new SMEG warming drawer.

Our consumer department is of course at your service, because we want to do our best to meet your expectations with regard to our products. We will be happy to respond to your questions or suggestions.

These "new valuables" serve as landmarks in our daily lives – SMEG, a reference for excellence, extends an invitation to join a new art of living.

The SMEG trademark.

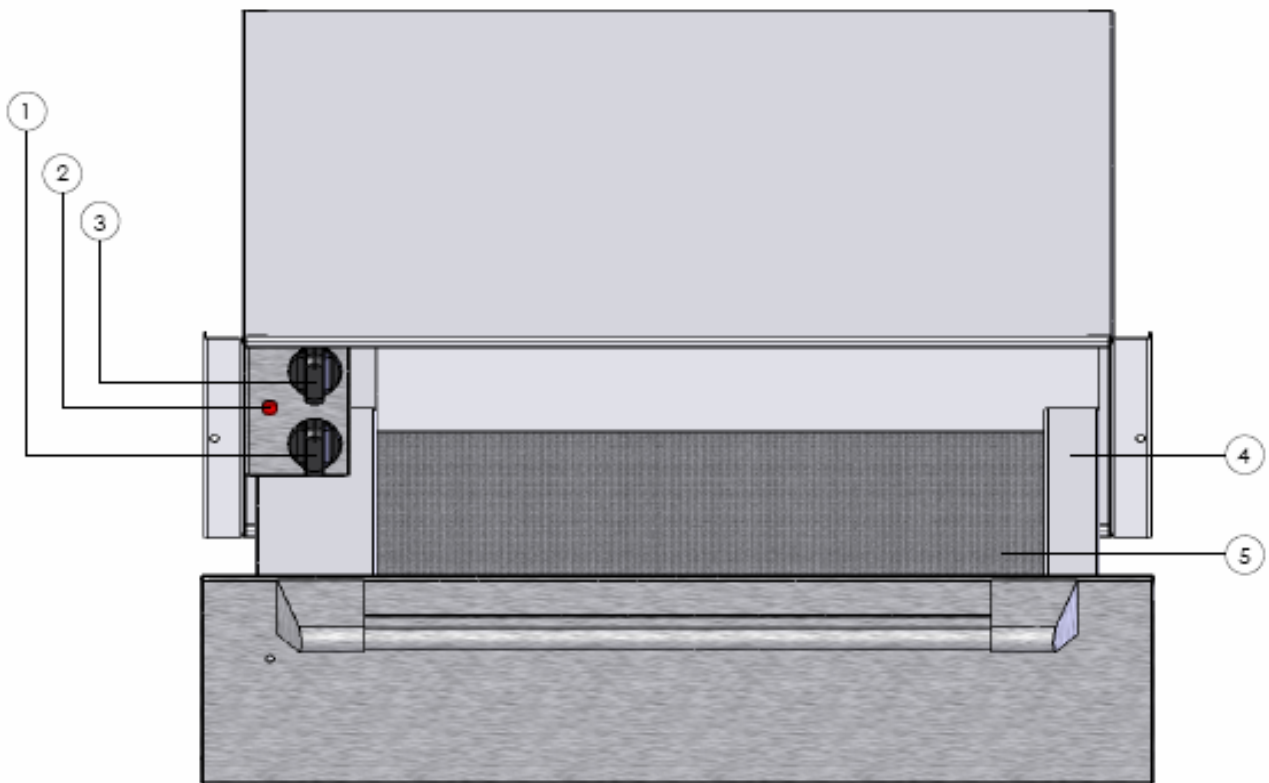

1. Timer, stop/start switch
2. Signal light on the front showing that power is on
3. Temperature control
4. Drawer for dishes
5. Antiskid mat

Safety tips

Keep these instructions with your appliance. If the appliance should be sold or given to another person, be sure that these instructions are supplied with it.

Please read these recommendations before installing and using your warming drawer. They have been drafted for your safety and that of others.

This warming drawer has been designed for use by private persons in their homes. It is intended exclusively for warming dishes. Any other use is prohibited and could be dangerous. The manufacturer cannot be held liable in the event of non-complying use.

Do not use this appliance until it has been installed in the cabinet. Only full installation of the drawer prevents any risk of contact with powered components.

Never open the body of the appliance.

The inside of the drawer can heat up 70°C depending on the temperature chosen and the duration of use. Use hot-pan holders or gloves to remove the hot dishes.

Do not use the warming drawer to keep food or drinks hot or to reheat or cook food or drinks. The moisture in the food or drinks could cause corrosion of the appliance.

Do not stand or sit on the open drawer; this would damage the telescopic rails. The maximum load of the drawer is 20 kg.

Do not store any plastic goods or inflammable objects in the appliance. They could melt or catch fire when it is turned on.

The appliance is not intended for use by young children or infirm persons without supervision.

Young children should be supervised to ensure that they do not play with the appliance.

Before connecting the appliance to the power supply, check that the wires of your electric installation have sufficient diameter to supply power to the appliance normally. The fuse for the installation should be 10 amps.

It is necessary to provide a bipolar cut-off device in the power supply circuit, where the opening of the contacts is more than 3 mm.

The electric connection should be done before the appliance is set in the cabinet.

The drawer should be connected by the (standard) power cord with three 1 mm² couplers (1 single phase + 1 N + ground) to the 220-240 V single phase power supply via an electric circuit corresponding to the standard CEI 60083 or complying with the installation rules. The protective wire (green/yellow) corresponds to ground (⊕) on the appliance and should be connected to the ground of the installation.

In the case of a connection via an electric outlet, the outlet should be accessible after the installation of the appliance.

The neutral on the heating drawer (blue wire) should be connected to neutral on the power supply.

If the supply lead is damaged, it must be replaced by an equivalent lead (H05RNF 3x1mm²) available from the after-sales department.

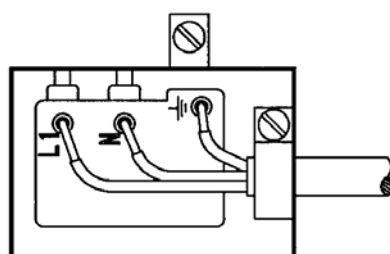

Encasement

Set the appliance into the niche in the cabinet. Make certain that the body of the appliance is positioned correctly.

Open the drawer and fasten the appliance to the sides of the cabinet with 2 screws and the 2 spacers delivered with the appliance.

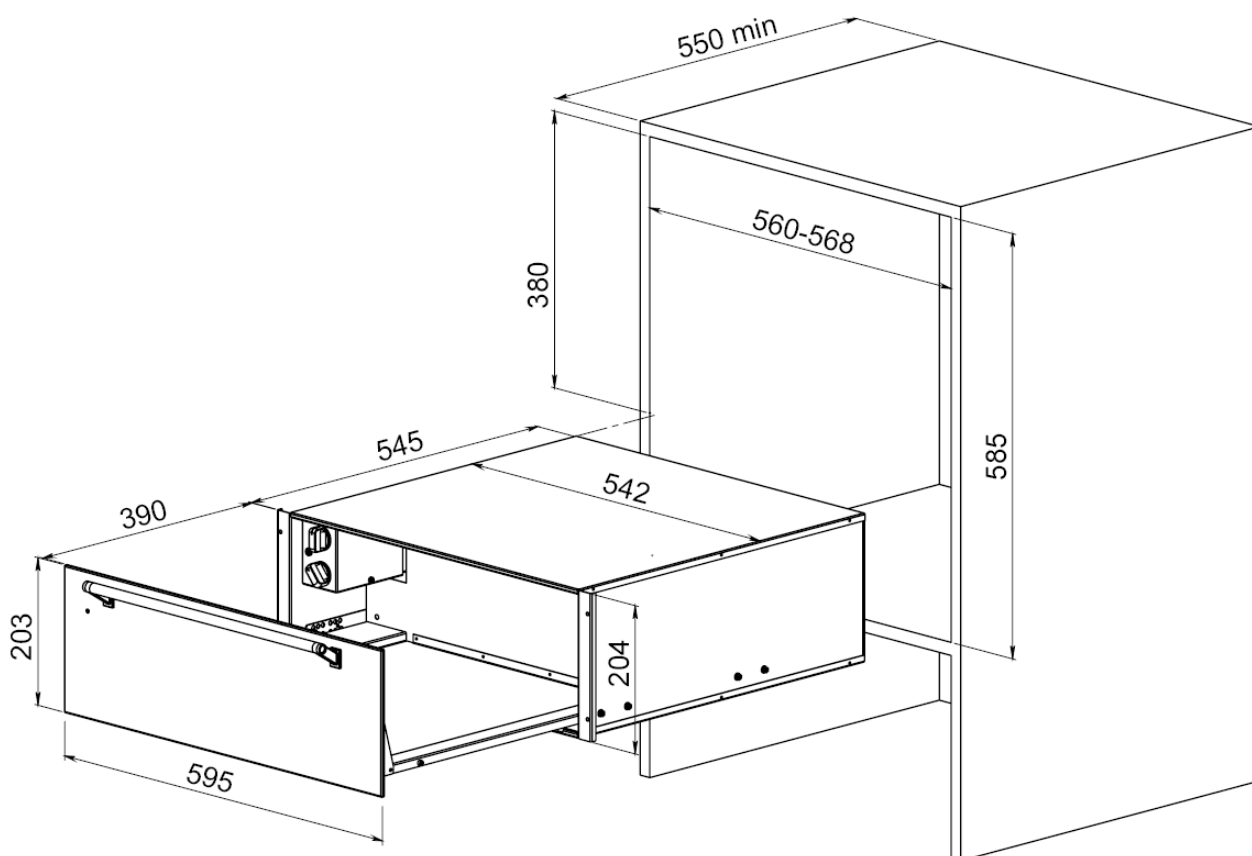

INFORMATION BEFORE USE:

The appliance should be used exclusively to preheat dishes.

The appliance uses a hot air system to heat the dishes. A fan distributes the heat from the resistor in the drawer. The dishes are heated rapidly and uniformly by circulation of hot air.

A protective grid prevents the dishes from coming into contact with the resistor or the fan.

The floor of the drawer is covered with an antiskid mat that prevents the dishes from sliding when the drawer is opened.

CONTROLS:

The controls include a temperature knob and a Start/Stop switch. These are only visible when the drawer is open.

When the drawer is closed, the signal light on the front of the drawer comes on when the appliance is running.

SETTING THE CONTROLS:

- Put the dishes in the drawer.
- Select the temperature.
- Set the timer (minimum 10 minutes).

The signal light shows that the power is on.

- Close the drawer

When the timer runs out, the hot air heating system stops and a bell rings.

To turn the bell off, turn the knob to 0.

Using your warming drawer

SELECTING THE TEMPERATURE:

The temperature knob adjusts the temperature between 30 and 70 °C.

The most appropriate temperatures for the types of dishes used are as follows :

- 40 °C: for cups or glasses. Hot drinks stay hot longer when poured into cups or glasses preheated to this temperature.
- 60 °C: for plates and dishes. Food served on preheated plates or dishes maintain their heat.

PREHEATING TIME:

Preheating time depends on several factors:

- the thickness of the dishes and the material they are made from
- the load
- disposal of the load
- temperature setting

Consequently, we cannot give times that will correspond systematically.

A few hints :

For a temperature setting of 60 °C, heated evenly:

- dishes for a meal for six take about 30 min.
- dishes for a meal for twelve take about 40 min.

After using the drawer a few times, you will know for yourself how long it takes to heat your dishes.

CAPACITY:

Capacity depends on the height of the model, and the weight and size of your dishes.

This model has maximum capacity of 20 kg.

The following examples are given as an indication only :

Quantities are determined by weight	
Dishes for 9:	
9 dinner plates	Ø 28 cm
9 soup plates	Ø 22 cm
1 serving bowl	Ø 22 cm
1 serving bowl	Ø 20 cm
1 serving bowl	Ø 18 cm
2 serving platters	36 cm
or 24 large plates Ø 28 cm	
+ 16 bowls	Ø 10 cm
or 36 soup plates Ø 22 cm	
+ 8 bowls	Ø 10 cm
or 60 bowls (± 330 g each)	Ø 10 cm
or 90 cups	Ø 8 cm

Cleaning and maintenance

Before any maintenance, turn off the appliance and let it cool.

Clean all surfaces with a sponge, dish washing soap and warm water. Then dry it off with a soft cloth.

Do not steam clean the appliance.

The use of scouring powders, alcohol or grease-cutting products is not recommended – they could damage the appliance.

The stainless front can be scratched. Use a special non-abrasive cleanser for stainless steel.

The antiskid mat can be removed to clean the bottom of the drawer.

The antiskid mat can be washed with warm water and dish water soap. Then dry it off and put it back in the drawer when it is completely dry.