

91 477 1247



technology with style

Operations Manual

for
60 and 90 cm wide
Electric Ovens



OVEN OPERATIONS MANUAL

INTRODUCTION

Congratulations on purchasing a SMEG oven, one of the most advanced cooking appliances available world wide. This book has been written to help you familiarise yourself quickly and easily with the full range of features your oven has to offer.

The Italians are world famous for their culinary flair and expertise. Smeg has distilled centuries of skill and knowledge to produce a range of cookers combining effectiveness and practicality.

This oven will probably require some changes in your cooking technique, correct cooking function selection and lower cooking temperatures will help to achieve the desired results. Use the trial recipes to help become familiar with the techniques required.



CONTENTS

APPLIANCE DIMENSIONS	3
INSTALLATION INSTRUCTIONS	5
FIRST USE	6
OVEN TIMER CONTROL	7
OVEN CONTROLS	12
CARE AND MAINTENANCE	14
COOKING TECHNIQUES	17
TRIAL RECIPES	25
SERVICE	38

Note

This Smeg Oven Operations Manual covers most current models. Some functions and features described in this book may not be available on the oven you have purchased.

APPLIANCE DIMENSIONS

◆ 60 CM WIDE OVENS

These dimensions apply to all Smeg 60 cm wide ovens. Special installation and technical supplements are available from your supplier.

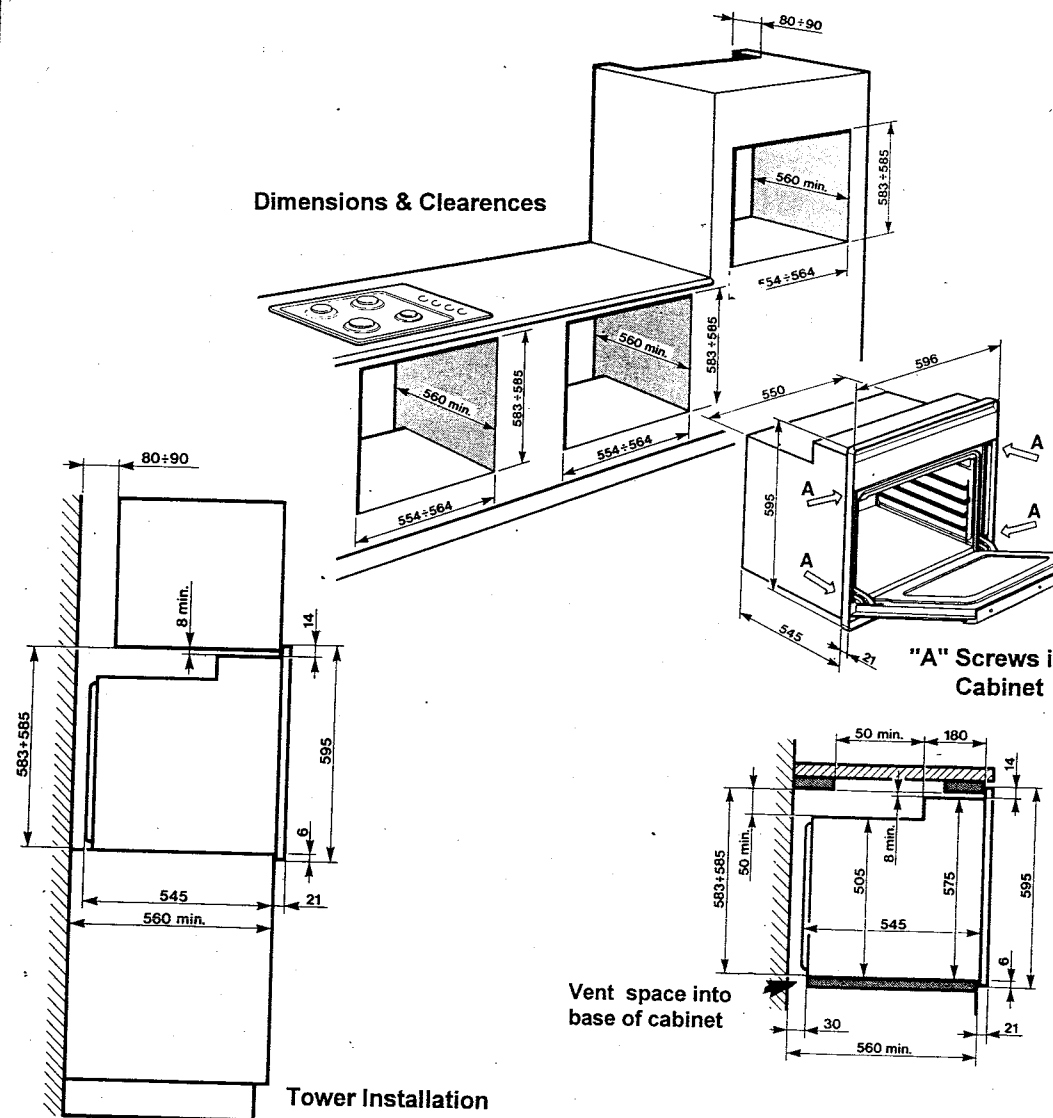

APPLIANCE DIMENSIONS

◆ 90 CM WIDE OVENS

These dimensions apply to all Smeg 90 cm wide ovens. Special installation and technical supplements are available from your supplier.

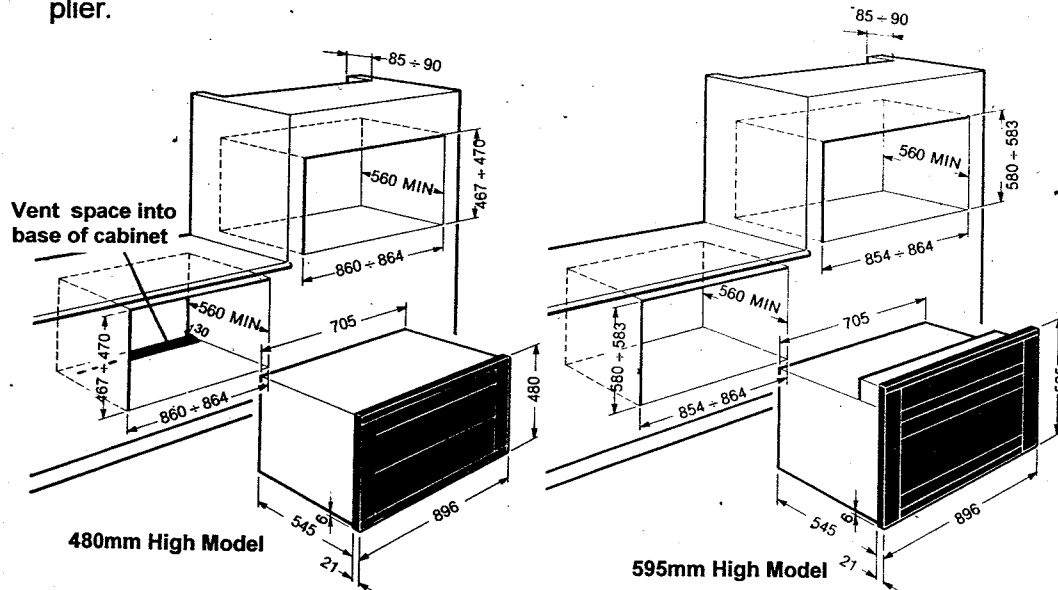

480mm High Model

595mm High Model

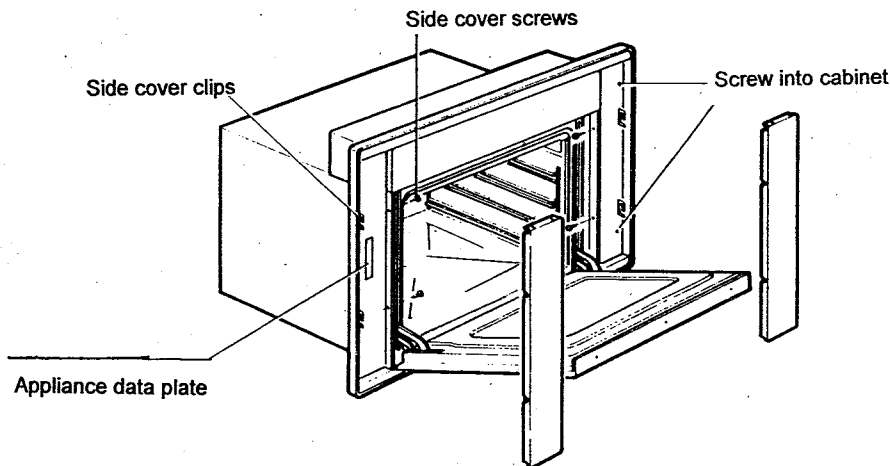

INSTALLATION

◆ CABINETRY

Notes:

This appliance is designed to be installed into a purpose designed cabinet ensuring all the dimensions, clearances and ventilation requirements described and shown in the Appliance Dimensions are correct.

- The cabinet material must be capable of withstanding 120° C.
- After installation into the cabinet, all ovens require fixing in place using the screws provided. Positions marked "A" on drawings.
- Be careful during installation not to put any pressure on the oven door or use it to lift oven into cavity.

◆ ELECTRICAL INSTALLATION

The electrical requirements for installation of this appliance vary from state or country. You must check the installation requirements that apply in your area.

Notes:

- All Smeg ovens are connected single phase, 230-240 volts, 50Hz~.
- Check Data Plate on appliance for maximum electrical load. (max 3kw)
- This appliance must be adequately earthed / grounded.
- Access to terminal block is gained by removing the back panel of the oven.
- **DO NOT** connect the supply cable to the 3 single colour test tails that protrude from the back cover.
- The Terminal Block on the oven is marked L. N. E. connect correctly to these markings, **DO NOT** consider the wire colours inside the appliance as indication of correct polarity.
- Leave at least 1.5 metres of cable to allow full removal of the oven from the cabinet.
- **DO NOT** connect this appliance together with any other electrical load. It requires a separate circuit and is to be protected by a circuit breaker as close to the maximum load as possible.

This appliance must be solidly earthed or grounded.
No responsibility is held for failure of appliance nor damage to property or persons caused by not ensuring proper earthing or earth connection by the installer.

FIRST USE

◆ INSPECTION

- Please inspect your appliance thoroughly for any damage. Report any defects to your retailer or refer to the service phone numbers in the Service section.
- Check the door opens and closes freely and that the oven door seal is correctly positioned and intact.
- Unpack all accessories and fill out the **Warranty Card**. We recommend you keep this card and your original purchase invoice stapled to back cover of this book.

◆ INSTALLATION CHECKS

Check that your installer has screwed this oven onto it's cavity. (Ref pg 3-4.)

◆ ACCESS - Models with retractable handle and knobs.

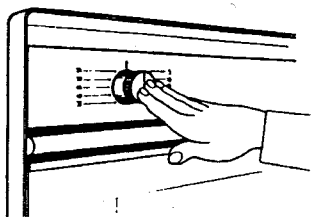

Function selectors

☛ Push in and release

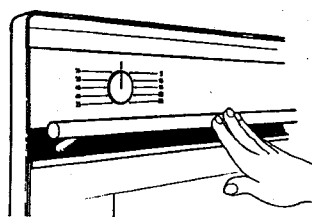

Retractable oven handle

☛ Push in and release

[Also see notes under cleaning and servicing]

◆ BURNING IN ELEMENTS

After installation and setting the clock, switch on each oven function one at a time with the thermostat set at 130°C and the oven door open to first notch. Each function should be operated for 10 minutes. A smell will be quite noticeable, this is the oil burning off which was put on to protect the elements during shipping.

◆ CAVITY COOLING FAN

Many Smeg ovens have additional cooling fans. These fans switch on when any function is selected (including light only) or automatically at > 60°c depending on model. This fan draws air in at the top of the oven and returns it to the room through the lower trim ventilating the cavity around the oven. On models fitted with automatic fan control the fan will run on for some time after the oven is switched off.

OVEN TIMER CONTROLS

◆ CLOCKS AND TIMERS

Note,

Four different timers / programmers are covered in this section, Your oven will clearly have one of these types.

MINUTE MINDER

Manual setting 0 to 60 minutes, bell warning.

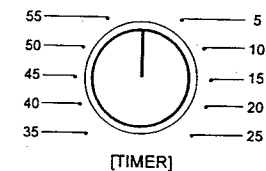

ELECTRONIC CLOCK -PROGRAMMER

6 push button with 24 hr digital display.

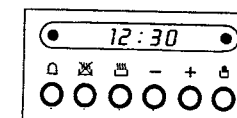

ANALOG CLOCK - PROGRAMMER

12 hr, programmable, minute minder.



ANALOG CLOCK

Manual with end of cooking alarm.
(Standard and Colonial versions.)

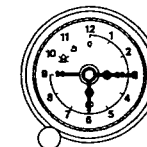
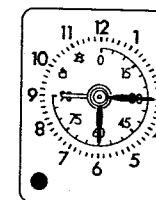

Refer to:- setting instructions relevant to your model.

☐ Minute Minder

Function - Set time 5-60 minutes, timer counts down and bell sounds. Timer operates independently of oven functions.

Operating - Wind timer all the way clockwise and then return anti-clockwise to set desired time. Bell warning sound does not mean oven has switched off.

Electronic clock - Programmer (3 digit display)

- Functions**
- 24hr time of day display.
 - Minute Minder with alarm.
 - Automatic start and end of cooking time
 - Automatic end cooking time

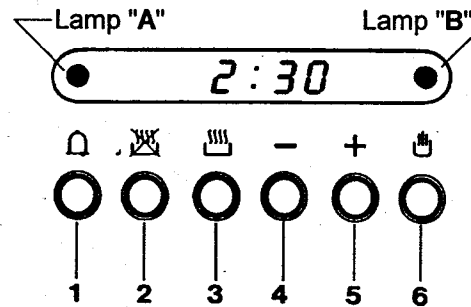

- ① - Set Minute Minder timer
- ② - Set End "cooking time"
- ③ - Set Length of "cooking time"
- ④ - Set Decrease time
- ⑤ - Set Increase time
- ⑥ Set Manual / automatic operation

Setting Time Of Day.

OPERATION

Steps:

- [1] 00:00 should be flashing in display. (Reset by switching off power to oven.)
 - [2] Press and hold button ② & ③ together at the same time.
 - [3] Press button ④ - OR ⑤ + to adjust time of day. eg 13:00 (1.00pm)
 - [4] Release all buttons.. Lamp "B" will be illuminated and flashing.
 - [5] Press button ⑥ once. Lamp "B" will go out and stop flashing.
- Clock is now set to time of day.-

Setting Minute Minder.

steps:

- [1] Press and hold button ① display will show 0:00
 - [2] Press button ⑤ + to set time required, 0-99 min.
 - [3] Release all buttons. Lamp "A" will be illuminated. Display will revert back to time of day after 3 seconds. To check and display time left on Minute Minder press again button ①.
- Alarm buzzer will sound at end of set time, it will automatically stop after 3 minutes or cancel by pressing ① again.

Setting Automatic Start and End Time.

steps:

- [1] Press button ③ and set *amount of time required to cook meal* with button ⑤ eg. 1:30 (1hour 30 min.)
 - [2] Press button ② and set *time the meal is required to be ready* .eg 18:00 (6pm)
Programming in a start time is not required.
 - [3] Lamp "B" will start flashing showing oven is in Auto mode.
Display will return to show time of day.
- Do not forget** to set a cooking function and temperature for automatic cooking.
- [4] Press button ⑥ cancels auto mode and returns timer to manual operation, pressing ⑥ again toggles between manual and auto modes.

Setting Automatic End - Cooking Time

steps:

- [1] Press button ③ and set *amount of time required to cook meal* with button ⑤ + . eg. 1:30 (1hour 30 min.)
- [2] **Set a cooking function and temperature for automatic cooking.**
Lamp "B" will illuminate, display will show 'time of day' and programme will begin counting down to turn oven off automatically at end of set time.
Alarm sounds to indicate time is up and oven has switched off.
- [4] Press button ⑥ cancels auto mode and returns timer to manual operation.

□ Analog clock - Programmer.

- Functions**
- Time of day display
 - Minute minder 0 - 210 min.
 - Auto end time programme with alarm.
 - Auto start with cooking duration programme.

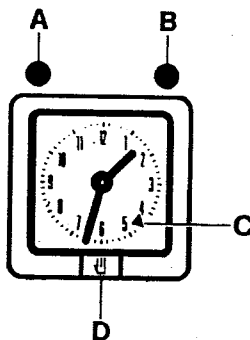
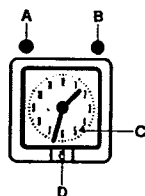

OPERATION

Setting Time Of Day.

steps;

- [1] Power must be switched **on** to the oven.
 - [2] Pull out knob "B" and turn in either direction to set correct time of day.
 - [3] Push in and turn knob "A" in either direction (this moves the arrow ► pointer visible in the clock face); align this pointer up with the hour hand on the hour of day. A small click may be felt when correct positioning is made.
- The oven is now in manual mode and ready to use.-

Setting Auto End Time.

Sets the oven to automatically turn **off** after a set period of the time (max 3hrs 30 min = 210 minutes)

steps:

- [1] Turn knob "B" counter - clockwise until the desired period of time is displayed in the window "D" eg. 120 min.
- Oven will turn off after time has elapsed, a warning bell will sound.
- [2] Turn bell off by turning knob "B" clockwise so the  symbol appears in window "D".

Setting Auto Start And End.

steps:

- [1] Turn knob "B" clockwise to set *length of time required to cook meal*.
 - [2] To set **start time** push and turn knob "A" to move arrow ► pointer round to the desired start time. Not more than 12 hrs in-advance.
 - [3] Set the required cooking function and oven temperature.
- Bell will sound at end of programme. ie. cooking time.
- [4] Return clock to manual mode by turning knob "B" to  manual symbol

□ Analog Clock

- Functions**
- Time of day display
 - End of cooking time alarm.

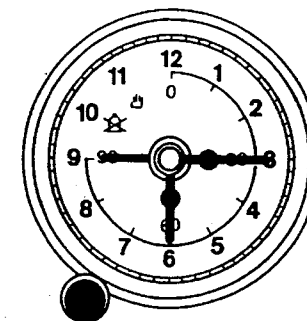
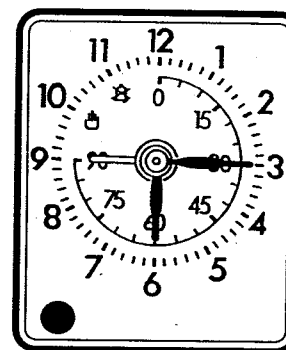

OPERATION



Setting Time Of Day

steps:

- [1] Press knob in and turn counter-clockwise and set hands to correct time of day.
 - [2] Without pressing, turn knob counter-clockwise to align marker hand to manual symbol 
- Oven is now ready for use.-

Setting End Of Cooking Time Alarm.

steps:

- [1] Without pressing the knob turn counter-clockwise to move the marker hand to the desired time. Max time is 90 min.
- [2] Set oven function and temperature and oven will start, a warning bell will ring at end of set time.
- [3] To cancel warning bell turn knob and move marker hand to  symbol.
- [4] Move marker hand to  manual symbol to return to manual operation

OVEN CONTROLS



The thermostat control allows you to choose the required cooking temperature.

The thermostat gives variable temperature selection between 50°C and 250°C. **Temperatures exceeding 200°C are generally not required**, use of excessive temperatures can cause a build up of cooking vapours and uneven browning of food.

The grill or symbol 'max' mark on the thermostat should be used only for very short periods, maximum of 10 minutes.

The oven heating indicator light on the front control panel comes on when the thermostat is energised and goes out once it has reached the selected temperature. At any time this light is on the elements are heating.

SPECIAL NOTES - MODEL S600 OVEN

The temperatures on Smeg oven model S600 are selected in fixed zones.
- THERMOZONE SYSTEM -

These settings have been carefully arranged to offer maximum flexibility and ease of operation. When converting your existing recipe temperatures to this zone selection system, start by deducting 30°C and then selecting the temperature zone which is lower than that temperature.

50	100	130	160	190	220	250
warming		warm oven	moderate oven	hot oven	very hot oven	

Example

Your recipe calls for 200°C, deduct 30°C = 170°, now select zone 160° (not 190°).

Note

As with any new cooking appliance, some experimentation with exact temperatures and cooking times will be required.



The Smeg range of 60cm and 90 cm wide ovens are true multifunction ovens, featuring 5 or 6 cooking modes and either "Fan Assisted" or "Fan Forced" cooking systems depending on model.

Selection of the correct function and oven temperature is important to obtain the best results.

The symbols and description of functions listed below apply to the range of Smeg ovens. Your oven depending on model will have a combination of functions and symbols described.

Further description of what function to choose depending on food type is covered in greater depth under the *COOKING TECHNIQUES* section.

The Smeg oven is primarily a fan oven. Always use a fan function as a preference where possible. To conserve and retain heat during cooking, **always** turn function selector back to a static (non-fan) mode before opening the oven door. Caution! When opening oven door do so in two distinct stages (1) crack door open a little for a few seconds then (2) open fully.

OVEN FUNCTION SELECTION GUIDE

FUNCTION SYMBOLS		DESCRIPTION OF OPERATION
		OVEN LIGHT- Oven light on independently.
		STATIC BAKE- Upper & lower heating elements.
		STATIC GRILL- Full width infra-red grill element.
		½ WIDTH STATIC GRILL- Centre section grill element.
		FAN GRILL- Grill element with fan assistance.
		THERMO-FAN- Lower element + fan assistance.
		THERMO-WAVE- Top & bottom elements + fan
		FAN FORCED- Fan + surrounding fan element.
		FAN FORCED- Fan + surrounding fan element. (90cm)
		SUPER FAN FORCED- Fan & element+ lower element.
		DEFROST- Fan only (do not use thermostat)
		ROTISSERIE GRILL- Electric grill + rotisserie spit drive.

CARE AND MAINTANENCE

◆ CARING FOR YOUR OVEN

As a precaution always switch **off** power to oven before commencing any cleaning or maintenance.

Regular and thorough cleaning will keep your appliance looking good for a very long time.

◆ CLEANING PROCEDURES

- Wipe the exterior surfaces regularly using a 'cream cleaner' or 'spray on - wipe off' type cleaners that are safe on painted surfaces. Do not use chemicals or abrasive materials.
- The interior of the oven also needs regular wiping out with warm water and detergent. Full scale cleaning will depend on the amount the oven is used and if it is fitted with **Continuous Clean** liners. (C.C. liners are optional extras on some models)

GUIDE TO RECOMMENDED INTERIOR CLEANING PROCEDURE.

Procedure	Weekly	Monthly	6-months	Comments
Wipe out with damp cloth.	●			Use warm water and detergent
Remove side racks and clean separately.		●		Use Scotch-brite or steel soap pads
Remove roof liner and clean.		●		Use warm water and detergent
Remove C.C. liners and clean separately			●	Use only warm water and detergent
Strip completely, clean oven thoroughly			●	Use spray on oven cleaner.

Removing And Cleaning The Side Racks

- Un-screw nut "A" & "C" and pull racks slightly towards the centre of the oven. these racks will fit in most dishwashers, regular washing in this way keeps racks very clean.
- When reinstalling racks always put a little cooking oil on the thread of the stud "A" stopping the nut seizing on at a later date.

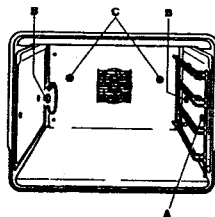

Care Of Continuous Clean Liners

Never Spray any chemical cleaner on to these liners nor use abrasive scourers. Wash only with warm or hot water and soap detergent.

- If the liners become clogged or very dirty, besides washing, operate oven at 200°C for 20 minutes a day over 3-5 days with normal cooking in between.

Cleaning Accessories

- Interior parts like roof liner, lower element cover and enamel trays once removed can also be cleaned with chemical oven cleaners or scouring pads.
- Grill and roasting racks should be left to soak with a little detergent before cleaning.

◆ OVEN DOOR SEAL

Keep a check on the oven door seal, it must be intact at all times. If it becomes broken or worn **REPLACE** immediately.

- To remove seal "A" lift from Tab "B"
- Sponge seal with soap and hot water.
- Re-mount seal "A" keeping the longer side horizontal and inserting tabs "B" into the 5 holes "C" starting with upper holes.

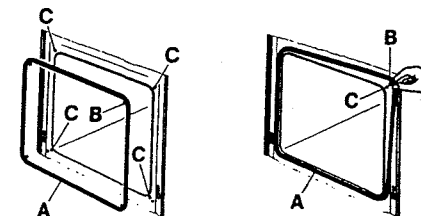

◆ CHANGING THE OVEN LAMPS

Replacement lamps are available from Smeg dealers or Smeg service centres. Do not try to fit lamps other than a genuine replacement part.

- Switch off power to oven.
- Unscrew glass cover "A" by turning anti-clockwise.
- Screw out lamp and replace.
- Refit glass cover, ensure ring "B" is in place.

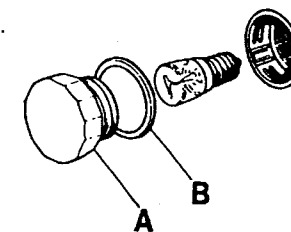

◆ REMOVING THE OVEN DOOR

steps:

- [1] Open door fully.
- [2] Hinge style ① - lift catch "B" and hook into arm "C" on both sides.
- [2] Hinge style ② - using your thumbs push tabs "B" firmly forward while closing the door slightly till the tabs latch in position.
- [3] With hands clasping either side of the door lift as if closing the door to about 30% closed. Lift slightly and pull the door forward removing from oven. *If you need to force the door it is not in correct position.*



◆ REFITTING THE OVEN DOOR

steps:

- [1] The parts "A.B.C." must be latched together.
- [2] Place the door in front of the oven at a position about 70% open.
- [3] Fit the long arms "C" into the top slots on the oven sides, keeping the door square so both arms go in together.
- [4] Lift the door up and back towards you slightly until you feel the long arms catch in their slots.
- [5] Lower the door as if opening, inserting the lower arm "A" into bottom slot on oven side. (guide in with forefinger)
- [6] Make sure the notch in arm "A" engages in on the lip of the oven hinge section.
- [7] Try to wiggle the door from side to side, it should be firm and clearly latched into the oven. If force is required to fit the door then the position is incorrect.
- [8] Open door fully, this will release the latches on hinge type ②, release catch "B" on type ① hinges.
- [9] Close the door slowly and check it is closing correctly, door is square and not binding on any part.

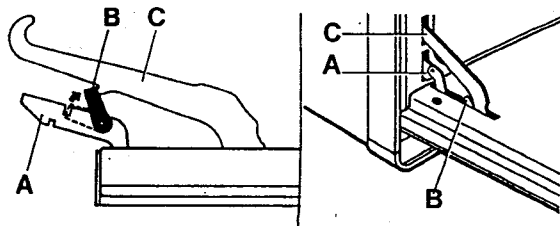

Tabs "B" latch arms "A". Tab "B" may be released once the weight of the door is felt while closing.

Hinge style ①

Hinge style ②

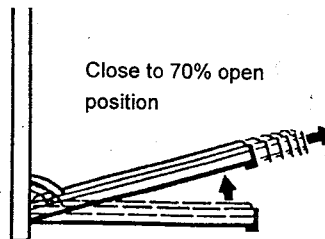

Removal and refitting position



COOKING TECHNIQUES

◆ ABOUT THE OVEN

- Obtaining the best from your Smeg oven may require some changes to your traditional methods of oven operation. This will be especially true if you are new to FAN ovens.
- This is a non-venting (Thermoseal) oven and only very small amounts of cooking vapour escape from the oven during the cooking process. All heat and moisture are largely retained in the oven. This higher level of moisture retention results in far less drying out of the food.
- Food tends to cook more quickly and at lower temperatures. As a guide you should reduce your traditional recipe temperatures by 20° to 30° C for use in a Smeg oven.
- Due to the non-venting oven concept, it is normal for the oven to produce moderate quantities of steam. Open door in two distinct stages, (1) crack door open a little, hold there for a few seconds then, (2) open fully.
- Always pre-heat the oven for a few minutes. This allows the oven liners to dry, pre-heats the internal surfaces and starts the cavity venting process.
- The oven light remains on during all cooking functions allowing you to check on progress without having to open the door.
- When you open the door during cooking on a fan function always TURN the function selector back to a static (non-fan mode) first. This helps conserve and maintain oven heat.

◆ RACKS AND POSITIONS

- The Smeg ovens are equipped with different racks depending on model and size, ie. 60 or 90 cm wide.
- Wire oven racks are off set on the ends to give two positions in each side rack slot.

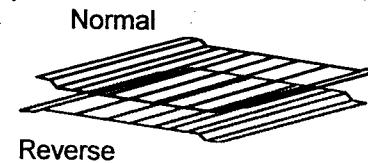

Reverse

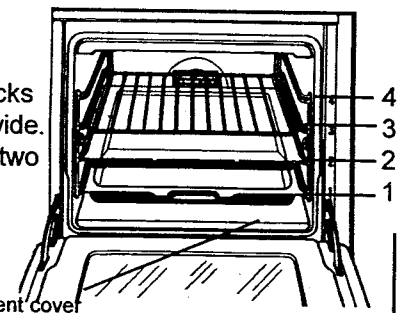

Lower element cover

Description of racks as used in trial recipes.

◆ COOKING FUNCTION SELECTION

Each of the multifunctions available is ideally suited to cooking specific food in the best possible way. Each function is described in more detail below.

Static Baking.

- The oven operates with top bake element and bottom element only. The lower element is situated under the removable lower element cover or, on 90cm models, beneath the oven cavity floor.
- The heating from these elements is slower than in fan mode.
- Temperatures should not exceed 200°C. Long cooking times at high temperatures should be avoided.

Static Grill.

- **This function must be used with extreme caution!** And only for food types as recommended in the Cooking Function Selection Chart, (pg 24).
- Conventional "open door style grilling"
- Oven produces intense heat from top grill element. Thermostat setting from 160° to 230° can be used to control grill heat, use  or "max" symbol on thermostat for very short periods only!
- Watch food carefully while cooking on this mode.
- Half grill (economy grill) some models have this option for quick grilling small portions.
- **60cm** models, pull roof liner out 100mm and rest oven door up against it, this protects front of oven from the intense heat and vapours.
- Some **90 cm** models have the guard shown, to be fitted when open door grilling.

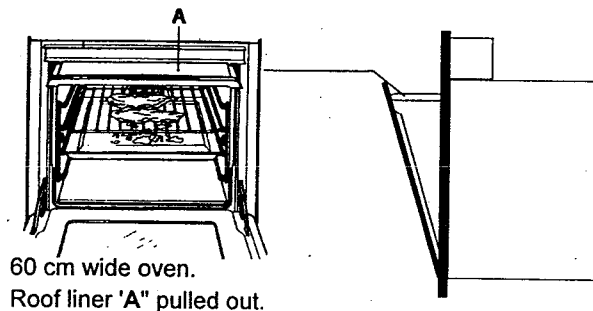

60 cm wide oven.
Roof liner 'A' pulled out.

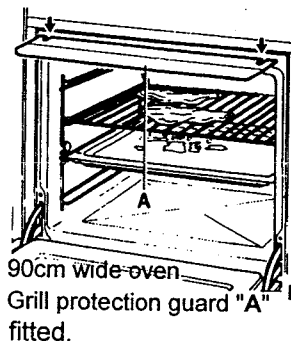

90cm wide oven
Grill protection guard "A" fitted.

Fan Grill.

- This function replaces the standard method of open door grilling, The grill element at the top produces intense heat to sear the surface while the fan moves this heat around the oven eliminating the need to turn food during grilling process, however turning is optional depending on desired results.
- This function produces rotisserie style cooking where the heat turns around the food. Food should always be elevated on grill rack.
- The oven door is kept closed during "fan grilling"
- Lower temperatures are important, set oven temperatures from 160 to 200°C.
- These relatively low temperatures do not reduce cooking time but prevent food from burning and avoids splashes of fat, keeping oven cleaner.
- Position racks at heights according to food type and thickness.
- Preheat oven fully for grilling fast cooking products. Generally a 5 minute preheat is all that is required.
- Turn oven function back to Static grill before opening door, after placing food return to fan grill.

Fan Grill Cooking Chart

Food Type	preheat	temperature	shelf position	cooking time min
Lamb or Pork chops	yes	190	4	8 ~ 12
Steak	yes (fully)	190 ~ 200	4	7 ~ 10
Chicken wings or pieces	yes	160	3	9 ~ 15
Sausages	yes	150 ~ 180	3	12 ~ 15 (turn)
Fish	yes	160	3	10 ~ 15
Browning dishes & toppings	optional	150 ~ 175	2-3	15 ~ 25

Notes on fan grilling - Steak.

To achieve a grid effect on the underside of Steak, fully preheat oven and grill rack together at 180 - 190°C

Cleaning up.

Grilling is generally considered fairly messy. In 60cm ovens the wire grill rack sits below the level of the grill dish. After use fill the tray with hot water and detergent, reverse rack and allow to soak before rinsing off or placing in dishwasher.

Remove roof liner from oven and rinse or wipe over.

Fan Forced

- This function will be the most used, all roasting, baking, multi-level baking and multi-level mixed product cooking, casseroles and heating is done using this function.
- It is possible to cook several different types of food at the same time without mingling of flavours.
- Heat is produced on the very hot fan element. This circular element surrounds the fan and produces hot air that is distributed evenly around the oven.
- Keep door closed during "fan forced" cooking. Remember! switch back to "static heat" mode before opening oven door, - turn back to "fan forced" to continue cooking.
- A short period of preheating is important, 3 to 5 minutes is all that is required.
- Temperatures are important! We mentioned earlier that as a rule of thumb lower your traditional recipes by 20 to 30°C, temperatures between 150° and 180° work best when cooking on "fan forced". This does not preclude the need to use higher temperatures for pastries and similar items.

Thermowave

- This function is available on some models in place of "fan forced", "Thermowave" or (fan assisted) uses the top bake element and the lower bake element on together with the fan to help distribute and even out the oven temperature.
- The features and useage is very similar to "fan forced", heat up time will be a little slower, but all cooking techniques are still the same.

Super Fan Forced (90cm ovens)

- This function is available on 90cm wide ovens. It incorporates the fan element with part of the lower element to increase to overall energy and heating speed of the larger oven.
- All uses of this function are similar to those described above as "fan forced".
 - ☛ See cooking selection chart for best use.

Notes on fan forced cooking - roasting.

Cook roasts etc elevated on oven racks to allow hot air to circulate round food. Expose food directly to heat, oven bags and covered roasting dishes are not recommended.

Do not add water during roasting, oven system produces a self basting action. Small roasts up to 1.8Kg can be cooked together with vegetables all at the same time.

ROASTING TIMES AND TEMPERATURES

MEAT	COOKED	TEMPERATURE degrees C	MINUTES PER 500 GRAMS
BEEF	Rare	180 - 190	15 plus 15 extra
	Well done	160	20 plus 20 extra
LAMB or HOGGET	Medium Well done	150 - 160	15 plus 20 extra 20 plus 20 extra
MUTTON	Well done	150 - 160	30 plus 20 extra
PORK	Well done	150 - 160	30 plus 30 extra
VEAL	Well done	150 - 160	30 plus 30 extra
CHICKEN	Well done	160 - 180	20 plus 15 extra

Thermo-fan

- Thermo-fan is a special function combining the lower bake element together with the oven fan. This produces gentle heat with fan assistance to distribute the heat.
- This function is suitable for slow delicate cooking processes.
- Preheat the oven on "Fan Forced" or "Thermowave" before switching to "Thermo-fan".
- Do not attempt to use high temperatures, 130 to 160°C are the maximum.
- Use only lower rack positions or directly on lower element cover.
- Always turn function selector back to a static heating mode before opening oven door.

Notes on Thermo-fan cooking

Select for:

- Rich fruit cakes.
- Long slow cooking at low temperatures.
- Frozen pies direct from freezer.
- Delicate pastries.
- Baking requiring extra base cooking.

Rotisserie cooking

- Some Smeg ovens have the option of rotisserie spit cooking either as a full function or in place of "Fan forced"

Model with separate Rotisserie symbol.

- Place meat on rack "A" secure with sliding clamps and insert drive end into hole at back of oven, fit front support rack, place tray under and close door.
- Switch function selector to rotisserie symbol. Set thermostat at 160 to 180° C
- Preheat oven for 5 minutes.

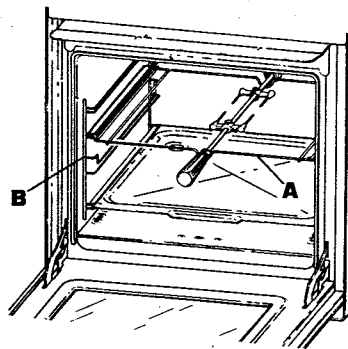

Model with turn-spit option.

- The two spit supports "A" must be mounted on the tray for this type of cooking.
- Prepare food and **secure well** onto spit with pointed clamp.
- Place complete unit in the first runner position from the bottom, guide in and align drive arm into hole "B" at rear of oven, this starts the drive motor operating.

Select oven function

"Fan grill" temperature 160 to 190° C food cooking on skewers, small roasts and small poultry.

Use "Fan forced" 130 to 180° C for large roasts and game requiring longer slower cooking.

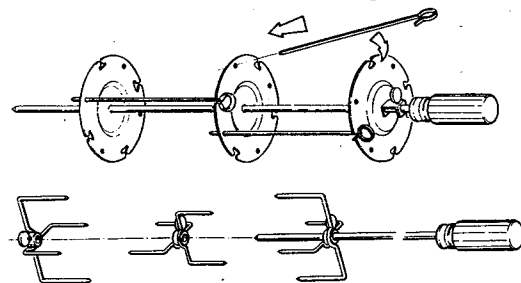
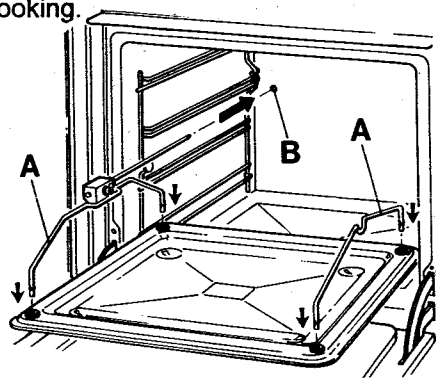

Rotisserie accessories

MAXIMISING THE OVEN

The Techniques described here also apply to those ovens with the Thermowave function only.

Examples for fan grilling.

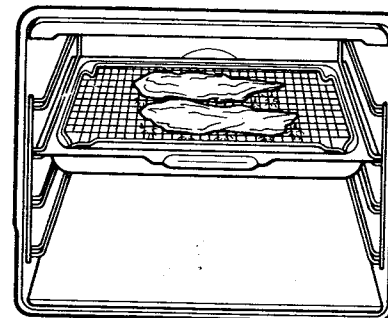

- Meat is placed on the grill grid inside grill tray.
- Meat is elevated to allow hot air to circulate around food.
- While "fan grilling" other food such as casseroles, lasagne, garlic bread etc can be cooking at the same time.
- The very bottom of oven i.e.. The lower element cover can be used to place dishes on.

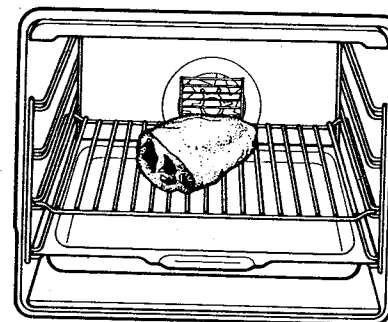

Examples of fan forced roasting.



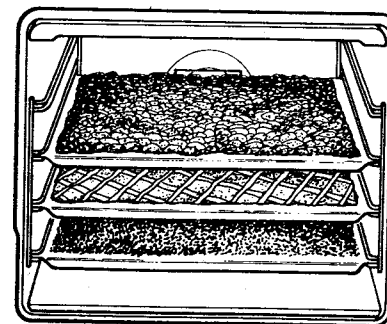





- For larger roasts or Turkeys place on wire oven rack with either the grill tray or shallow baking dish under.
- Vegetables can be placed on this dish to brown and crisp with the meat drippings.
- Smaller meat cuts or chickens, use the grill grid and tray, but elevate food to allow hot air to circulate around food.
- The very bottom of the oven or extreme top rack can be used to heat other dishes at the same time or to warm plates.



Examples of fan forced multi-level baking.

- Use multiple shallow baking trays or other baking dishes
- Preheat the oven until it begins to cycle on thermostat at set temperature.
- Turn off fan before placing in food, then return to fan mode.

COOKING FUNCTION SELECTION GUIDE

FUNCTION	fan forced	super fan forced	thermowave	fan grill	static grill	static bake	thermo-fan	rotisserie
FOOD TYPE								
MEATS								
Roasts	•	•	•					•
Small cuts				•				
Steak				•				
FISH								
Whole	•	•	•					
Fillets	•	•	•	•				
POULTRY								
Whole	•	•	•					•
Pieces	•	•		•				
COMPLETE OVEN MEALS	•	•	•					
EGG RECIPES								
Custards						•	•	
Souffles						•	•	
Pavlova						•		
Quiche	•		•			•	•	
PIZZA	•	•	•			•		
PIES & PASTRY	•	•	•					
BAKING	•		•					
1 Tray	•		•			•		
2-3 Trays	•	•	•					
Fruit cake	•		•			•	•	
Multi-product	•	•	•					
Large cakes	•	•	•					
TOPPINGS								
Au Gratin dish				•				
Crumb toppings				•	•			
PASTA DISH	•	•	•					
TOAST								
Cheese on toast				•	•			
Fast grill snack				•	•			
Grilled tomatoes				•	•			

TRIAL RECIPES

The following recipes have been developed to give you an introduction to the basics of the Smeg oven and the correct use of the functions available.

EASY TO FOLLOW RECIPES BY
GLENYS HENRY

STATIC BAKING

EASY MIX PAVLOVA
SIMPLE SAVOURY SOUFFLE

STATIC GRILLING

GARLIC TOASTIES
GARLIC CRUMB MUSSELS

FAN GRILLING

SIZZLING STEAK
DEVILLED CHICKEN
SAUSAGES WITH SPICY CHIPS

FAN FORCED

LEMON GARLIC LAMB ROAST
MUSHROOM SPINACH STRUDEL
APRICOT CHOC CHIP BISCUITS

THERMO-FAN

CHRISTMAS CAKE
CREME CAMEL

EASY MIX PAVLOVA

INGREDIENTS:

- 2 Egg whites
- 1½ c Castor sugar
- ½ t Vanilla essence
- 1 t White vinegar
- 1 t Cornflour
- 4 T Boiling water

OVEN SETTING:

Temperature	Start at 150° - 160°C Reduce to 100°C
Function	Conventional (no fan)
Preheat	15 minutes
Shelf Position	Third from top

METHOD

Combine all ingredients in small electric mixer bowl. Beat on high speed until mixture is very stiff (approx 15 minutes). Brush tray lightly with melted butter, dust with sifted cornflour, shake off excess. Pile mixture onto prepared tray. Shape as desired.

Place in preheated oven. Bake for 10 minutes. Reduce heat to 100°C. Bake for a further 30 minutes. Turn heat off. Open oven door 4 to 5 cm and leave pavlova to cool in oven.

This recipe produces a crisp pavlova with a marshmallow centre.

Note

It is essential to have a dry bowl and beaters for a good result. Also ensure no yolk gets into the whites when separating the eggs.

SIMPLE SAVOURY SOUFFLE

INGREDIENTS:

- 100 g Butter
- 4 T Plain flour
- 1 c Milk
- ½ c Grated tasty cheese
- ¼ c Crushed pineapple, thoroughly drained
- 2 T Chopped parsley
- 2 T Chopped salami
- 4 Eggs

OVEN SETTING:

Temperature	160° - 175°C
Function	Conventional (no fan)
Preheat	15 minutes
Shelf Position	Third from top

METHOD

Melt butter in medium saucepan. Stir in flour, blend thoroughly. Gradually add milk in three portions, cooking between additions to form a thick smooth sauce.

Stir cheese, pineapple, parsley and salami into sauce. Season to taste with salt, pepper, mustard, etc.

Separate eggs. Beat egg yolks until pale and fluffy.

Clean and dry beater. Using a clean bowl beat egg white until moist short peaks form. Stir egg yolks into sauce using a thin edged spatula. Fold in egg whites in two portions, taking care not to break down the aeration. Lightly grease a 21cm souffle dish. Pile mixture into dish and bake at 160°C for 35 to 40 minutes or until well risen, browned and set to the centre.

Hints

Sauce may be cooked in the microwave oven. Gradually blend milk into combined melted butter and flour mixture. Microcook, high power, 4 to 6 minutes stirring once.

GARLIC TOASTIES

INGREDIENTS:

- 4 Bread rolls
- 50g Butter
- 1 Clove of garlic
- 2 T Chopped parsley

OVEN SETTING

Temperature	160 - 210°C
Function	Static grill, Open oven door, Pull out top element cover 100mm, Position oven door back against element cover (approx 20% open).
Preheat	5 minutes
Shelf Position	Second from Top

METHOD

Cut rolls in half. Soften butter. Crush garlic. Combine butter, garlic and parsley. Butter cut rolls
Arrange rolls on oven rack, butter side up. Toast 3 to 5 minutes until crisp and golden.

GARLIC CRUMB MUSSELS

INGREDIENTS:

- 24 Mussels
- ½ c Water

GARLIC TOPPING:

- 2 ½ c Soft breadcrumbs
- 2 Cloves garlic, crushed
- 2 T Chopped fresh chives, finely chopped.
- 75 g Butter

OVEN SETTING:

Temperature	160 - 190°C
Function	Static grill

METHOD

Grill for 4 - 6 minutes until crumbs are crisp and golden brown. Serve immediately.

Tips for static grilling

Use open door grill to brown the top of dishes cooked in the microwave oven. Select full grill heat and cook 5 to 8 minutes or until surface is crisp.

SIZZLING STEAK

INGREDIENTS:

2 to 6 Sirloin steaks
1 T Soy sauce)
1 T Worcestershire sauce)
1 T Brown sugar) per steak
1 Clove garlic)
1 t Oil)

OVEN SETTING:

Temperature 180 - 190°C
Function Fan grill
Preheat Fully for approx. 10 - 15 minutes,
until thermostat cuts out with grill
pan in place

Shelf Position Top shelf, grill pan & grid

METHOD

Combine marinade ingredients. Score fat on steak to prevent curling during cooking. Add steak to marinade. Allow to marinate for a minimum of 15 to 20 minutes.

Set oven to preheat fully. Fan grill, 190°C with grill pan on rack in the oven top shelf position.

Turn oven fan off. Open door. Arrange steaks on pre-heated grill rack & tray. Close oven. Turn fan on. Fan grill steaks for 6 - 10 minutes according to personal taste. Rare - well done.

Note

Steaks will not require turning during cooking unless they are very thick. Remember to turn oven fan **off** before opening the door. Turn control to static grill while the door is open then back to fan grill when the door is closed again.

DEVILLED CHICKEN

INGREDIENTS

1.5 kg chicken pieces
½t salt
1 t sugar
½t ground pepper
½t ground ginger
½t dry mustard
½t curry powder

OVEN SETTING

Temperature 160°C
Function Fan grill
Preheat 5 minutes
Shelf Position Second from top, grill grid & pan

METHOD

Combine salt, sugar, pepper, ginger, mustard & curry powder.

Dry chicken pieces with paper towel. Rub spices into skin. Stab skin with a fork to allow flavours to penetrate and fat to come to surface.

Arrange chicken pieces on grill grid over grill pan.

Fan grill, 20 to 25 minutes or until chicken produces clear juices when tested.

LOW FAT VARIATION

Remove skin from chicken pieces. Combine selected spices with ½ cup of plain yoghurt. Add ½ t turmeric or paprika for additional colour. Coat chicken pieces in spiced yoghurt mixture before cooking.

SAUSAGES WITH SPICY CHIPS

INGREDIENTS:

- 2 Large kumara
- 2 T Cooking oil
- ½ t Curry powder
- ¼ t Ground cumin
- ¼ t Ground coriander
- 8 Uncooked sausages

OVEN SETTING:

Temperature	160°C
Function	Fan grill
Preheat	5 minutes
Shelf Position	Second from top, grill rack & tray

METHOD

Peel kumara. Cut into large chunky chips. Combine with oil and spices in a small bowl, mix well to coat evenly.

Arrange sausages and chips on grill grid over grill pan. Fan grill 160 °C 15 to 20 minutes, turning sausages and stirring chips once during cooking.

Note

Sausages do not require pre-cooking.

VARIATION

Use chunks of pumpkin and/or potato instead of, or as well as kumara. Any dried herbs or spices can be used in this dish. Vary spices according to personal taste.

LEMON GARLIC LAMB ROAST

INGREDIENTS:

- 2 kg Leg lamb
- ½ t Ground pepper
- 2 Cloves of garlic
- ¼ c Lemon juice
- ½ t Dried rosemary
- Roasting vegetables of your choice
- ¼ c Cooking oil or 125g melted butter

OVEN SETTING:

Temperature	150 - 160°C
Functions	Fan forced Fan grill
Preheat	5 minutes
Shelf Position	Third from top

METHOD

Wipe meat with absorbent paper, score fat/skin layer, season with pepper. Cut garlic into thin slivers, push into small slits in lamb. Brush lamb with lemon juice. Sprinkle with rosemary. Place grill rack over grill dish. Place meat on rack underside up. Fan cook at 150 - 160° C for 60 minutes. Peel vegetables. Cut into large pieces. Remove meat from oven. Turn over. Coat vegetables with cooking oil or melted butter. Arrange around meat on grill rack. Return to the oven. Turn oven to "fan grill". Fan grill at 150° - 160°C for a further 40 minutes or until vegetables are crisp and golden and meat is cooked through.

Note

Cooking time given in this recipe produces a well done roast.

MUSHROOM SPINACH STRUDEL

INGREDIENTS:

- 16 Medium spinach leaves (or 8 silverbeet).
- 1 t Cooking oil
- 300 g Mushrooms sliced
- 1 Medium onion finely chopped
- ½ c Cottage cheese
- ¼ t Ground nutmeg
- 1 Egg
- ¼ c Bacon or chopped ham
- 2 Sheets ready rolled puff pastry

OVEN SETTING:

Temperature	180 - 190°C
Function	Fan forced
Preheat	8-10 minutes
Shelf Position	Third from top

METHOD

Boll, steam or microcook spinach or silverbeet until limp. Squeeze out excess moisture.

Fry or microcook onion and mushrooms until tender (omit oil if microwaving).

Combine cottage cheese, nutmeg and egg in food processor. Process until smooth. Add spinach. Process until finely chopped. Stir in mushrooms, onion bacon and ham.

Join 2 sheets of pastry together. Spread filling down the centre. Moisten edges of pastry with milk. Fold pastry in half over filling. Seal edges. Slash pastry across the top at 3 evenly spaced intervals. Brush with milk.

Fan cook at 190°C for 20 to 25 minutes or until crisp and golden. Serve hot or cold with salad.

APRICOT CHOC CHIP BISCUITS

INGREDIENTS:

- 250g Butter
 - ½c Golden syrup
 - ½c Chopped apricots
 - ¼c Milk
 - 1t Baking soda
 - 1c Flour
 - 1c Sugar
 - 2c Coconut
 - 2c Rolled oats
 - ¾c Chocolate chips
- Makes approx 50.

OVEN SETTING:

Temperature	160 - 170°C
Function	Fan forced or "Super fan forced"
Preheat	10 minutes
Shelf positions	2 and 3

METHOD

Combine butter, golden syrup, and apricots in a small saucepan. Heat together stirring gently until butter has melted and all ingredients are combined.

Heat milk, stir in baking soda.

Combine flour, sugar, coconut, rolled oats and chocolate chips in a large bowl. Add butter/apricot mixture and milk/baking soda. Mix thoroughly. Roll into small balls. Arrange on 2 or three lightly greased oven trays. Fan cook at 160°C for 12 to 15 minutes or until golden brown. Cool briefly on a tray then on cake cooler. Store in airtight container.

CHRISTMAS CAKE

INGREDIENTS:

250g Butter	250g Sugar (1 cup)
4 Eggs	2 T Golden syrup
1kg Mixed dried fruit	½ t Lemon essence
½ t Almond essence	350g Flour (2½ cups)
½ t Ground cloves	½ Mixed spice
¼ t Nutmeg	½ t Baking soda
¼ c Hot milk	

OVEN SETTING:

Temperature	Start at 130°C Reduce to 100°C
Function	Thermo-fan
Preheat	Fully on "Fan forced" or "Thermo-wave function"
Shelf Position	2nd from bottom

METHOD

Line the base and sides of a 20cm square pan. Use one layer of foil on the base with at least two layers of lunch wrap or brown paper. Use three layers of paper on the sides.

Cream butter and sugar until light and fluffy. Beat in eggs one at a time, beating thoroughly between additions. Beat in essences and golden syrup. Sift together flour and spices. Add to creamed mixture then stir in fruit. Combine hot milk and baking soda. Mix thoroughly to ensure baking soda is dissolved then stir into cake mixture.

Pour into prepared tin. Level surface. Bake on "thermo-fan" at 130°C for 1 hour then reduce the temperature to 100°C and continue cooking for a further 1½ to 2 hours or until cake springs back in the middle and produces a clean skewer when tested.

Note

Lining the cake tin thoroughly is an essential part of achieving an evenly cooked result.

Store for up to two months wrapped in lunch wrap. Brush over from time to time with alcohol for improved flavour.

CREME CAMEL

INGREDIENTS:

2 T	Water
100g	Castor sugar (½ cup)
4	Eggs
50g	Castor sugar (¼ cup)
¼ t	Vanilla essence
550 ml	Milk (2½ cups)

OVEN SETTING:

Temperature	100°C
Function	Thermo-fan
Preheat	Fully on "fan forced" or "thermowave function"
Shelf position	2nd from bottom

METHOD

Combine 1T of water with the first measure of sugar in a small heavy based saucepan. Bring slowly to the boil and heat until beginning to caramelize, add remaining tablespoon of water and reboil until caramel and water mix. Pour into a four cup capacity oven proof mould. Swirl around to coat the sides and base of the dish.

Whisk together second measure of sugar, eggs and vanilla essence. Heat milk, without allowing to boil, gradually whisk into egg mixture.

Pour egg mixture through a sieve into mould.

Bake 45 minutes to 1 hour or until set to the centre.

Chill thoroughly before turning out onto serving dish.

Note

This dish would normally cook in a water bath at a much higher temperature. By selecting the Thermo-fan function and reducing the temperature by 60° C it cooks in the same amount of time without the water bath.

SERVICE

After sales service for your Smeg oven is supported by a National Service Network. The Warranty card included in with your oven covers warranty conditions and limitations.

Should you require service please follow the following procedures.

For Australia.

Service is provided through the service network as listed below.

<i>Area</i>	<i>Telephone No.</i>	<i>Facsimile No.</i>
Sydney	(02) 666 3100 sales & admin. (02) 316 8777 Service	(02) 666 5529 (02) 316 7528
Queensland	(07) 268 4911	(07) 268 3112
Newcastle	(049) 61 4811	(049) 62 2738
Canberra	(06) 280 7099	(06) 280 7137
Wagga Wagga	(069) 21 3888	(069) 21 4526
Victoria	(03) 761 1177	(03) 761 1373
Tasmania	(008) 133 840	(03) 761 1373
South Australia	(08) 346 1888	(08) 340 1034
Western Australia	(09) 356 5555	(09) 356 5556

Country callers can ring (1800) 815 581 and be connected to the appropriate Smeg distributor. This is a free call.

For New Zealand.

For service assistance contact the retailer where the appliance was purchased. The retailer will arrange service for you.

For national assistance,

Telephone (09) 634-0183

Facsimile (09) 634 5033



Australian distributor

Omega Appliances Pty Ltd
97 Banksia St,
Botany, NSW.
PO Box 55, Botany, NSW 2019
PH (02)666-3100

New Zealand distributor

Applico Group Ltd
120 Captain Springs Road,
Onehunga, Auckland
Private Bag 92900, Onehunga.
Ph (09) 634-5033

NOTES