



**Model 5434 & 5434KL**  
3/8" Capacity Straight Drill  
**Model 5434TB - 7/16" Tire Buffer**



**IMPORTANT**

Read these instructions carefully before installing, operating, servicing or repairing this tool. Keep these instructions in a safe accessible place.

SAFETY MESSAGES	WARNING	Operator Instructions
<p style="text-align: center; font-size: small;">Personal Safety Equipment</p> <p>Use – Safety Glasses           <b>YES</b></p> <p>Use – Safety Gloves</p> <p>Use – Safety Boots</p> <p>Use – Breathing Masks</p> <p>Use – Ear Protectors           <b>YES</b></p>	<p> <b>WARNING</b></p> <p> Always Read Instructions Before Using Power Tools</p> <p> Always Wear Safety Goggles</p> <p> Wear Hearing Protection</p> <p> Avoid Prolonged Exposure To Vibration</p>	<p><b>Includes:</b></p> <p>Safety Rules Foreseen Use Work Stations Putting Into Service Operating Dismantling and Assembly.</p>

**Safety rules when using a 5434 & 5434KL Drill or 5434TB Tire Buffer**

- Use may produce flying objects. Always use safety goggles.
- Use accessories rated at above 2,500 RPM.
- Prolonged exposure to vibration may cause injury.
- Read all instructions before using this tool. All operators must be fully trained in its use and aware of these safety rules.
- Do not exceed the maximum working air pressure.
- Use personal protection equipment as recommended.
- Use compressed air only at the recommended conditions.
- If the tool appears to malfunction, remove from use immediately and arrange for service and repair. If it is not practical to remove tool from service, then shut off the air supply to the tool and write or have written a warning note and attach it to the tool.
- If tool is to be used with a balancer or other suspension device, ensure that the tool is firmly attached to the suspension/support device.
- When operating the tool, always keep the body and particularly the hands away from the working attachment fixed to the tool.
- The tool is not electrically insulated. Never use the tool if there is any chance of coming into contact with live electricity.
- Always when using the tool, adopt a firm footing and/or position and grip the tool sufficiently only to overcome any reaction forces that may result from the tool doing work. Do not overgrip.
- Use only correct spare parts for maintenance and repair. Do not improvise or make temporary repairs. Major servicing and repairs should only be carried out by persons trained to do so.
- Do not lock, tap, wire, etc. the 'On/Off' valve in 'On' position. The throttle trigger/lever, etc. must always be free to return to the 'Off' position when released.
- Always shut off the air supply to the tool and press the 'On/Off' valve to exhaust the air from the feed hose before fitting, removing or adjusting the working attachment fitted to the tool.
- Before using the tool, make sure that a shut off device has been fitted to the supply line and the position is known

- and easily accessible so that the air supply to the tool can be shut off in an emergency.
- Check hose and fittings regularly for wear.
- Take care against entanglement of the moving parts of the tool with clothing, hair, ties, cleaning rags, rings, jewelry, watches, bracelets, etc. This could cause the body or parts of the body to be drawn towards and in contact with the moving parts of the tool and could be very dangerous.
- It is expected that users will adopt safe working practices and observe all local, regional or country legal requirements when installing, using or maintaining the tool.
- Take care that the exhaust air does not point towards any other person or material or substance that could be contaminated by oil droplets. When first lubricating a tool or if the tool exhaust has a high oil content, do not allow the exhaust air to come near very hot surfaces or flames.
- Never lay the tool down until the working attachment has stopped moving.
- When the tool is not in use, shut off the air supply and press throttle trigger/lever to drain the supply line. If the tool is not to be used for a period of time, first lubricate, disconnect from air supply and store in a dry average room temperature environment.
- If the tool is passed from one user to a new or inexperienced user, make sure these instructions are available to be passed with the tool.
- Do not remove any manufacturer fitted safety devices where fitted, i.e., wheel guards, safety trigger, speed governors, etc.

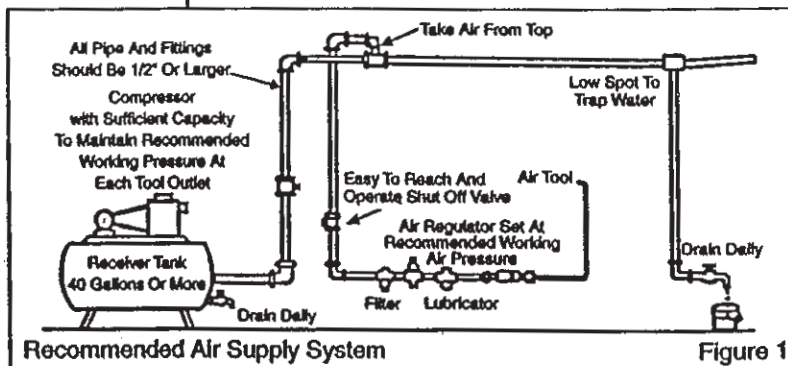

- Wherever possible, secure workplace with clamps, a vise, etc. to make it rigid so it does not move during the work operation. Keep good balance at all times. Do not stretch or overreach.
- Try to match the tool to the work operation. Do not use a tool that is too light or heavy for the work operation. If in doubt, seek advice.
- In general terms, this tool is not suitable for underwater use or use in explosive environments — seek advice from

manufacturer.

- Try to make sure that the work area is clear to enable the work task to be performed safely. If practical and possible, try to clear unnecessary obstructions before starting work.
- Always use air hose and couplings with minimum working pressure ratings at least 1 1/2 times the maximum working pressure rating of the tool.

## Foreseen Use Of The Tool – 5434 & 5434KL Drills / 5434TB Tire Buffer

The drill is designed for the purpose of drilling holes in all types of materials, i.e., metals, wood, stone, plastics, etc. using drilling bits designed for this purpose. It may be used with other forms of cutting tools, polishing devices or for sanding using coated abrasive products. Before using any such products, first check with the manufacturer their suitability for use with this type of drill. The tire buffer is designed for buffing tires and tubes by use of a pair of abrasive cup wheels in the form of a rasp. It is particularly useful in surface preparation prior to patching a tire or tube. For either tool model, do not use bonded abrasive products (i.e. grinding wheels) or saw blades or any device which has a permitted safe working speed less than the free speed of the drill. Do not use this tool for any other purpose than that specified without first consulting the manufacturer or the manufacturer's authorized supplier.

## Work Stations

The tool should only be used as a handheld, hand operated tool. It is always recommended that the tool is used when standing on a solid floor. It can be used in other positions, but before any such use, the operator must be in a secure position having a firm grip and footing and be aware that the drill can develop a torque reaction (see section "Operating").

## Putting Into Service

### Air Supply

Use a clean lubricated air supply that will give a measured air pressure at the tool of 90 PSIG (6.2 bar) when the tool is running with the trigger/lever fully depressed. Use recommended hose size and length. It is recommended that the tool is connected to the air supply as shown in figure 1. Do not connect the tool to the air line system without incorporating an easy to reach and operate air shut off valve. The air supply should be lubricated. It is strongly recommended that an air filter, regulator, lubricator (FRL) is used as shown in Figure 1 as this will supply clean, lubricated air at the correct pressure to the tool. Details of such equipment can be obtained from your supplier. If such equipment is not used, then the tool should be lubricated by shutting off the air supply to the tool, depressurizing the line by pressing the throttle on the tool. Disconnect the air line and pour into the hose adaptor a teaspoonful (5ml) of a suitable pneumatic motor lubricating oil preferably incorporating a rust inhibitor. Reconnect tool to air supply and run tool slowly for a few seconds to allow air to circulate the oil. If tool is used frequently, lubricate on daily basis and if tool starts to slow or lose power. It is recommended that the air pressure at the tool while the tool is running is 90 PSI/6.2 bar.

## Operating – Drills

Select suitable drill bit, insert the shank into the drill chuck as far as possible and tighten chuck making sure that the shank of the device is securely clamped centrally between three chuck jaws.

When drilling holes of all sizes, it is advised to use a pointed punch to mark the center at which the hole is to be drilled as this will provide a starting point for the bit tip. This procedure will prevent the drill bit from skidding, ensure that the hole is drilled where intended and help prevent drill bit breakage when using small drill bits. When drilling, particularly with small diameter drill bits, always try to ensure that load applied to the drill is such that the drill bit is always at right angles to the hole being drilled. Do not force the drill bit, but allow it to cut.

When drilling, always adopt a firm posture to be able to counteract any sudden movement of the drill due to torque reaction. Such torque reaction can occur when the drill stalls due to a too heavy load being applied or the material being too hard. The torque reaction can occur when the drill bit breaks through the material being drilled, particularly on sheet metal. Always use eye protection and hand protection when drilling holes in metals where the material being removed from the hole is in the form of long sharp strips. Do not tie the drill chuck key to the drill as the attaching device, i.e. string or chain could become entangled with the rotating chuck and bit etc.

If using an abrasive device, drilling stone or performing any operation where dust is created, it is recommended to use a breathing mask. Always ensure that the material to be drilled is firmly fixed to prevent its movement.

It is also recommended that when drilling holes of large diameter to first pre-drill a hole of smaller diameter as this will reduce effort required to drill the hole and minimize torque reaction.

When drilling, do not remove drill chips by blowing or wiping with bare hands. Stop the drill completely and use a cloth or brush to remove drill chips. Lubricating the tip of the bit will make drilling easier and improve the drilling action. The lever is the on/off valve for the tool. The drill operates in a clockwise direction.

An air strainer is part of the hose adaptor (14). Periodically check the strainer for blockage or if the drill slows or loses power. It can be easily cleaned by removing the hose adaptor.

## Operating – Tire Buffer

The lever (12) is the on/off valve. Select a pair of buffing wheel halves and check that they are not damaged or cracked and fit them on the quick coupling adaptor. Attach tool to a suitable air supply and start the tool for the first time away from other persons and in a safe area (i.e. under a heavy bench) and run for at least one minute to ensure the buffing wheels are sound. Wear a breathing mask and eye and ear protection. When using the tool, do not apply a heavy force to the buffing wheel or allow the surface being buffed to become hot. Apply light steady pressure or interrupted (momentary) pressure.

## Dismantling & Assembly Instructions

Disconnect tool from air supply.

To remove the chuck (33, 34, 35), grasp the tool in one hand and with the other hand, sharply twist the chuck in the direction to loosen a right-handed thread, i.e., the direction of rotation of the tool. Then grip the motor housing (1) in a vise fitted with soft jaws on the flats at the rear end of the housing. With a wrench, disassemble the nose housing (31) and pull out pins (28), washer (32). With a non-metallic or soft metal hammer, tap the work spindle (29) to remove the ball bearings (30), planet cage (25), and planet gears (26). To pull out the motor portion (17-24) from the housing (1), grip the area between the cylinder (22) and the front end plate (23), tap the teeth portion of the rotor (19), so as to separate the rotor from the front end plate (23), rear end plate (18) and the rotor blades (20) from the cylinder (22). Using a round bar approx. 6.2mm in diameter, tap the inside of the ball bearing (24) to separate the front end plate (23) from the ball bearing (24). In the same way, use the round bar to tap the inside of the ball bearing (17) to separate the rear end plate (18) from ball bearing (17). Pull out the pin (11), air regulator (8), spring (7), and pin throttle (6). Tap the throttle valve bushing (2) to remove. The hose adaptor (14) may be removed with a 17mm wrench, then muffler (16) can be removed as well.



**5434 & 5434KL 3/8" Capacity Straight Drills**  
**5434TB 7/16" Capacity Tire Buffer**

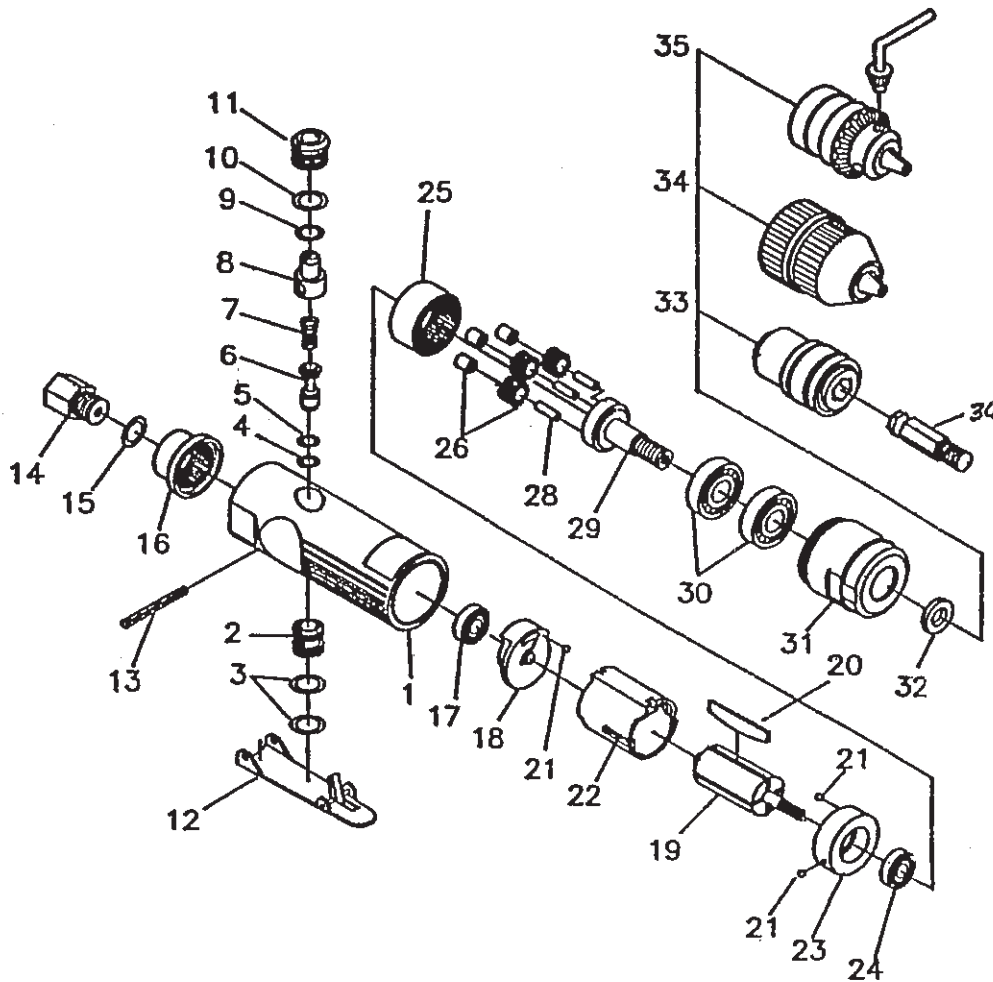

Ref. No.	Part No.	Description
1	505404	Motor Housing
2	66444	Throttle Valve Bushing
3	66518	O-Ring (2)*
4	66442	O-Ring
5	66451	O-Ring
6	66443	Throttle Pin
7	66441	Spring
8	66440	Air Regulator
9	66464	O-Ring
10	66458	O-Ring
11	66437	Valve Plug
12	66467	Safety Throttle Lever
13	66468	Pin
14	66469	Hose Adaptor
15	66429	O-Ring
16	66448	Muffler
17	66483	Ball Bearing
18	66434	Rear End Plate
19	505391	Rotor
20	66433	Rotor Blades (Set of 4)

Ref. No.	Part No.	Description
21	66414	Steel Ball (3)*
22	505392	Cylinder
23	505393	Front End Plate
24	66486	Ball Bearing (2)*
25	505394	Planet Gear
26	505395	Pin
27	505396	Work Spindle
28	505397	Planet Cage
29	505398	Ball Bearing
30	505399	Nose Housing
31	505400	Washer
32	66406	Spacer
33	67837	Chuck 7/16" Quick Change (Includes Fig.36)
34	67398	Chuck 3/8" Keyless
35	21133	Chuck 3/8" Keyed (Includes 30002 Key)
	30002	Chuck Key
	505403	Quick Coupler Adaptor
Not Shown	505402	Name Plate (5434)
Not Shown	505401	Warning Label

\*Order Quantity Needed



## Reassembly

Clean all parts and examine for wear and replace with parts obtained from the manufacturer or an approved distributor. Ensure that the face of the end plates (18, 23) that abut the cylinder (22) are flat, free from burrs and sharp edges. If necessary, lap on a flat, very fine grade of abrasive paper. Lightly coat all parts in a suitable pneumatic tool lubricating oil and pack bearings with a lithium or molybdenum general purpose grease and assemble the tool in reverse order above. With the lever (12) depressed, pour into hose adaptor (14) 5ml of a pneumatic tool lubricating oil. Release the lever and connect to a suitable air supply and run the tool slowly for a few seconds to allow the oil to circulate. Check the function of the air regulator and safety lever before returning to service.

### NOTES

Operation Specification	
Air Consumption	5 cfm (36 ccfm)
Torque Output	45 lbs. in. (5Nm) Stall Min.
Spindle Thread	3/8 - 24UNF
Air Inlet Thread	1/4-18NPT
Length	8.25" (210mm)
at 90 PSIG/6.2 bar	

### NOTES

<b>Manufacturer/Supplier</b> Sloux Tools Inc. 2901 Floyd Boulevard P.O. Box 507 Sioux City, IA 51102 U.S.A. Tel No. 712-252-0525 Fax No. 712-252-4267		<b>Product Type</b> Straight Drill / Tire Buffer	RPM <b>2,500</b> Cycles Per Min.	
		<b>Model No/Nos</b> 5434/5434KL <b>3/8" Capacity</b> 5434TB - 7/16" Capacity	Serial No.	
<b>Product Net Weight</b> 2.0 lbs 0.9 Kg	<b>Recommended Use Of                  Balancer Or Support</b> NO	<b>Recommended Hose Bore                  Size - Minimum</b> 5/16 Ins 8 M/M	<b>Recommended Max.                  Hose Length</b> 30 Ft 10 M	
<b>Air Pressure</b> Recommended Working 6.2 bar 90 PSI Maximum 6.2 bar 90 PSI		<b>Noise Level: Sound Pressure Level 83.5 dB(A)</b> Test Method: Tested In accordance with Pneurop test code PN8NTC1 and ISO Standard 3744		
<b>SAFETY MESSAGES</b> Personal Safety Equipment Use - Safety Glasses YES Use - Safety Gloves Use - Safety Boots Use - Breathing Masks Use - Ear Protectors YES	 <b>WARNING</b> Always Read Instructions Before Using Power Tools Always Wear Safety Goggles Wear Hearing Protection Avoid Prolonged Exposure To Vibration	<b>Vibration Level</b> 1.29 Meters / Sec <sup>2</sup> Test Method: Tested In accordance with ISO standards 8662 Part 1		

### Declaration of Conformity Sioux Tools Inc.

2901 Floyd Boulevard, P.O. Box 507, Sioux City, Iowa 51102

declare under our sole responsibility that the product

**Model 5434/5434KL Drills & 5434TB Tire Buffer, Serial Number**

to which this declaration relates is in conformity with the following standard(s) or other normative document(s)

**EN792 (Draft), EN292 Parts 1 & 2, ISO 8662 Part 1, Pneurop PN8NTC1**

following the provisions of **89/392/EEC as amended by 91/368/EEC & 93/44/EEC Directives**

  
**Jan E. Albertson (V.P./General Manager)**

Name and signature or equivalent marking of authorized person