

Simplicity

32" Heavy Duty Tiller
Mfr's No. 392

The 32" Heavy Duty Tiller is shipped from the factory in one carton. Before starting to assemble the tiller, be certain to remove all of the parts from the carton.

Assembly

For ease in assembling the tiller, follow the sequence of steps outlined below:

1. Remove all masking tape from the ends of the tine shaft and the drive pulley shaft of the chain guard assembly.

2. To attach the deflector assembly to the chain guard assembly; remove 2 mounting bolts from each side of the chain guard as shown in Figures 1 & 2. Mount the deflector so that the holes in the mounting brackets line up with the holes in the chain guard assembly as shown in Figure 3, and replace the mounting bolts in their original holes. Tighten the bolts securely.

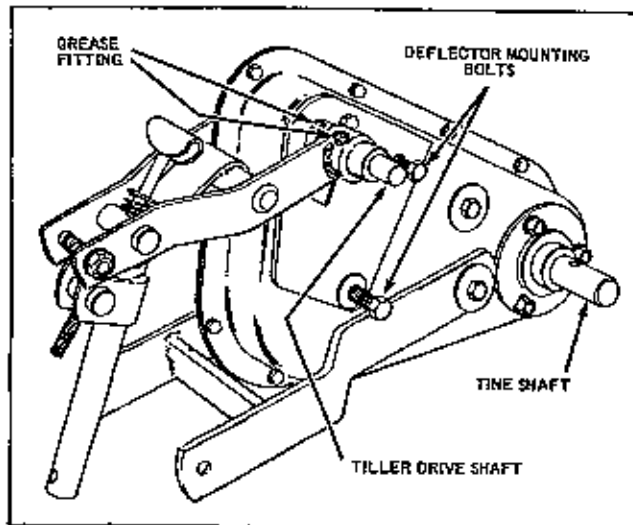

FIGURE 1

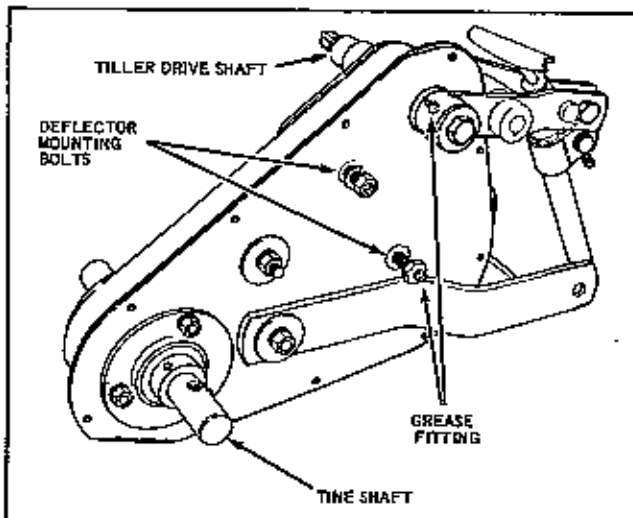

FIGURE 2

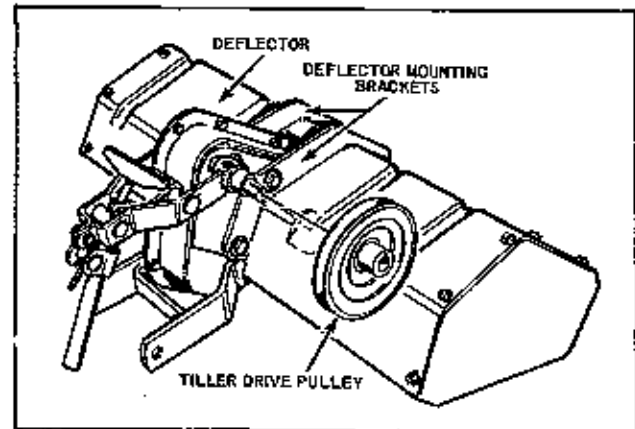

FIGURE 3

3. Assemble the left hand inner tine assembly to the left hand outer tine assembly and fasten with a pin and cotter pin. Assemble the right hand inner tine assembly to the right hand outer tine assembly, and fasten with a pin and cotter pin. NOTE: the inner tine assemblies can be identified by the constant diameter of the hub fastened to the tine plate. The long end of this hub is inserted into the long end of the hub of the outer tine assemblies and is fastened as described above.

CAUTION: As it is possible to mount the tine assemblies incorrectly to the tine shaft, pay particular attention to the following: Assemble the tines to the tine shaft as shown in Figure 4 so that the sharp edges of the top tines face toward the front of the tractor. Fasten the tines to the tine shaft with a pin and cotter pin on each end of the tine shaft. When the tines are mounted, check once more to be certain that the sharp edges of all tines face in the correct direction.

4. Attach the deflector and plates.

5. Assemble the tiller drive pulley to the tiller drive shaft as shown in Figure 3. The pulley is held in place by a key and set screw and is to be mounted with the hub of the pulley facing away from the chain guard.

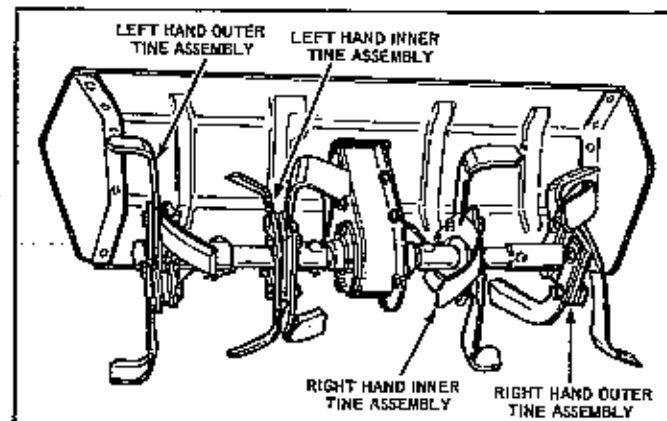

FIGURE 4

SIMPLICITY MANUFACTURING COMPANY, INC. 244674210

TP - 1278

Tiller Drive Assembly

For ease in attaching the tiller drive assembly to the tractor, follow the sequence of steps outlined below:

1. Fasten the belt release bracket to the outside of the side plate with the two 5/16" x 1" hex capscrews as shown in Figure 5.

2. Mount the tiller belt release guard to the belt release bracket as shown in Figure 5. The concave surface of the tiller belt release guard is to face the bevel gear shaft.

3. Mount the 3" tiller drive pulley to the bevel gear shaft with its key, as shown in Figure 5. The hub of the pulley faces in toward the tractor. Leave the set screw loose until making final alignment.

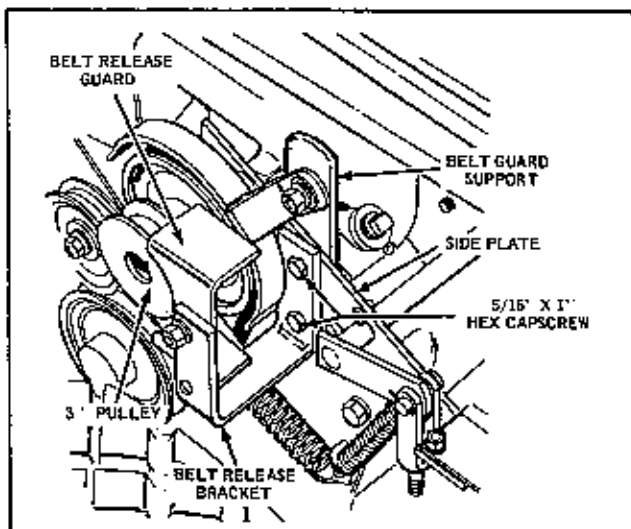

FIGURE 5

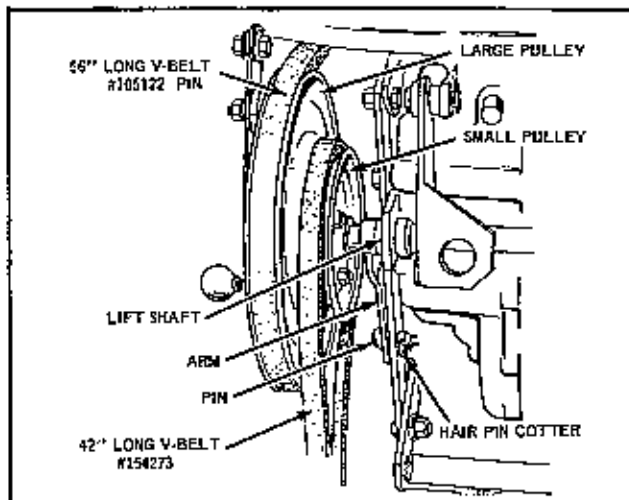

FIGURE 7

4. Place the 56" long V-belt #105122 in position on the 3" tiller drive pulley. (For ease of identification, the V-belts are marked with part numbers.)

5. Place the 42" long V-belt #154273 in position on the smaller pulley of the tiller drive assembly and mount the tiller drive assembly onto the lift shaft as shown in Figure 6. As is shown in Figure 7, the arm of pulley sleeve assembly is held in place against the left side bracket of the tractor tow assembly by means of a hair pin cotter and pin.

Place the free end of the 56" long V-belt #105122 in position on the large pulley of the tiller drive assembly as shown in Figure 6.

Position the 3" pulley so that it is in line with the large pulley of the tiller drive assembly and tighten the set screw securely.

6. Place the off-set end of the guide assembly rod into the hole in the belt release bracket and fasten in place with a hair pin cotter. See Figure 6.

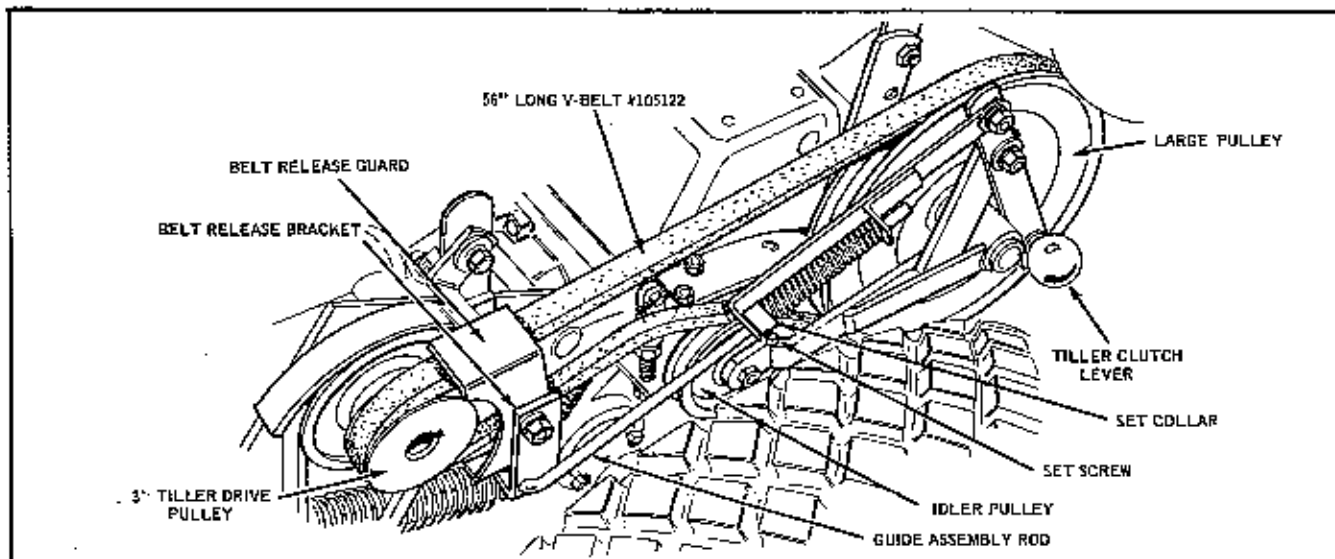

FIGURE 6

Attachment

For ease in attaching the tiller to the tractor, follow the sequence of steps as outlined below:

1. Place the tiller in position in back of the tractor. Pull the tractor lift lever to the full back position and place the tiller lift bar assembly into the tube of the rear lift assembly on the tractor. Fasten in place with a pin and hair pin cotter as shown in Figure 8.
2. Place the tractor lift lever in the forward position and connect the tiller frame to the tractor tow assembly with the pivot rod and hair pin cotters. See Fig. 8.
3. Turn the belt tension adjusting screw to the full loose position (turn counter-clockwise) and place the free end of the 42" long V-belt #154273 in position on the tiller drive pulley. With the V-belt in position on the tiller drive pulley and on the smaller pulley of the tiller drive assembly, turn the belt tension adjusting screw in a clockwise direction until the slack is taken out of the V-belt.
4. Pull up on the tiller clutch lever handle to engage the tiller, and adjust the belt release guard so that clearance is equal on both sides of the belt. See Figure 6.
5. Depress the tractor brake pedal and lock in position. Loosen the belt guard mounting bolt on the righthand side of the tractor and swing the belt guard out of position. Remove the tractor drive belt and remove the 6" pulley from the transmission drive shaft and replace with the 8" pulley #105188. Mount the 45" long V-belt #152017 from the 8" pulley to the pulley on the bevel gear shaft. Replace the belt guard and tighten the mounting bolt. Release the brake and clutch adjustments described in the tractor manual.

Lubrication

The tiller is lubricated through 2 grease fittings. One fitting is located on the tiller drive shaft housing and the other is located on the right hand side of the chain guard. See Figures 1 & 2. Lubricate these fittings every 3 hours of operation with a good grade of general purpose automotive type grease loaded in a standard grease gun. Be certain to wipe any dirt from the fittings before applying the grease gun. Failure to clean the grease fittings will result in grit being forced into the bearing surfaces along with the grease. Also apply a few drops of lubricating oil to the moving linkages of the tiller drive assembly from time to time.

Belt Tension

The two V-belts that transmit power from the bevel gear box to the tiller drive shaft are designed and manufactured to provide long and satisfactory service. Because of the special design of these belts, it is urged that you replace them only with genuine replacement belts ordered from your dealer. Consult the parts list for correct part numbers for these belts when replacement is necessary.

1. Adjustment of belt tension, for the V-belt running from the 3" pulley on the bevel gear shaft to the large pulley on the tiller drive assembly, is regulated by the set collar on the guide rod assembly. See Fig. 6. The tension should be correct when there is about 3/4" clearance between the collar and the bracket of the guide rod assembly when the tiller clutch lever is engaged.

To increase the tension, release the tiller clutch lever and loosen the set screw in the collar. Slide the collar towards the rear of tractor and retighten the set screw. Check the tension by engaging the tiller clutch lever. **AVOID EXCESSIVE TENSION** as it will cause premature belt failure.

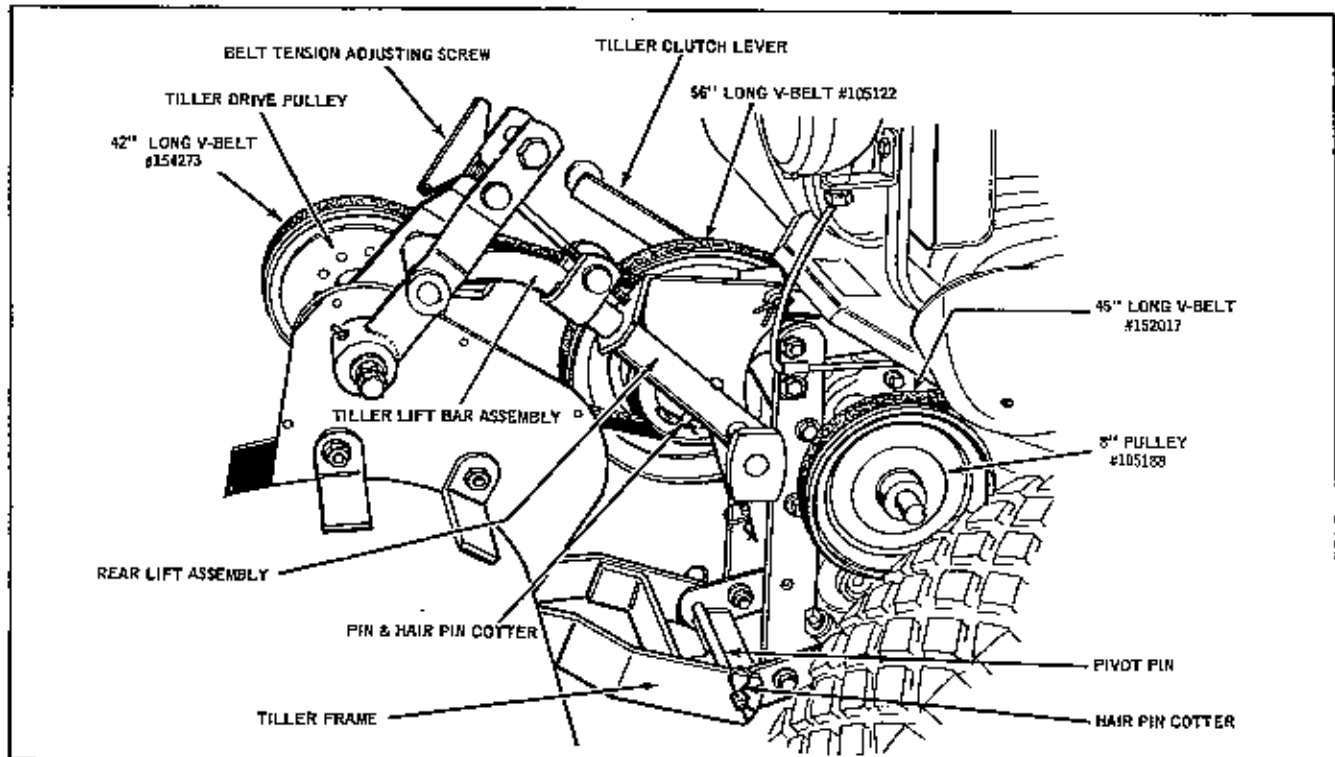

2. Adjustment of belt tension, for the V-belt running from the smaller pulley of the tiller drive assembly to the drive pulley on the tiller, is regulated by the belt tension adjusting screw. Turn the handle in a clockwise direction to increase the belt tension and counter-clockwise to decrease tension. The belt

should have tension sufficient to transmit power to the tiller drive shaft.

AVOID EXCESSIVE TENSION as it will cause premature belt failure.

OPERATION

Before starting the tractor engine, place the tiller clutch lever in the disengaged position and raise the tiller above the surface of the ground. With the tractor engine running, engage the tiller clutch and lower the tiller into contact with the ground. As the tiller works into the soil, slowly release the tractor clutch and move ahead. When coming to the end of a row, raise the tiller free of the ground before turning around.

Effective operation of the tiller will depend in a large degree upon the operator. For example; when intending to till a sod area into a seed bed for gardening, it obviously will require several passes over the same path to break the sod and ground into fine particles suitable for a seed bed. Depending upon the nature of the soil, it will be desirable to alter the depth settings for the tiller on succeeding passes until the desired depth is reached. When tilling in soil that has been previously worked, it may be possible to till to the desired depth from the start.

HOUSING GROUP

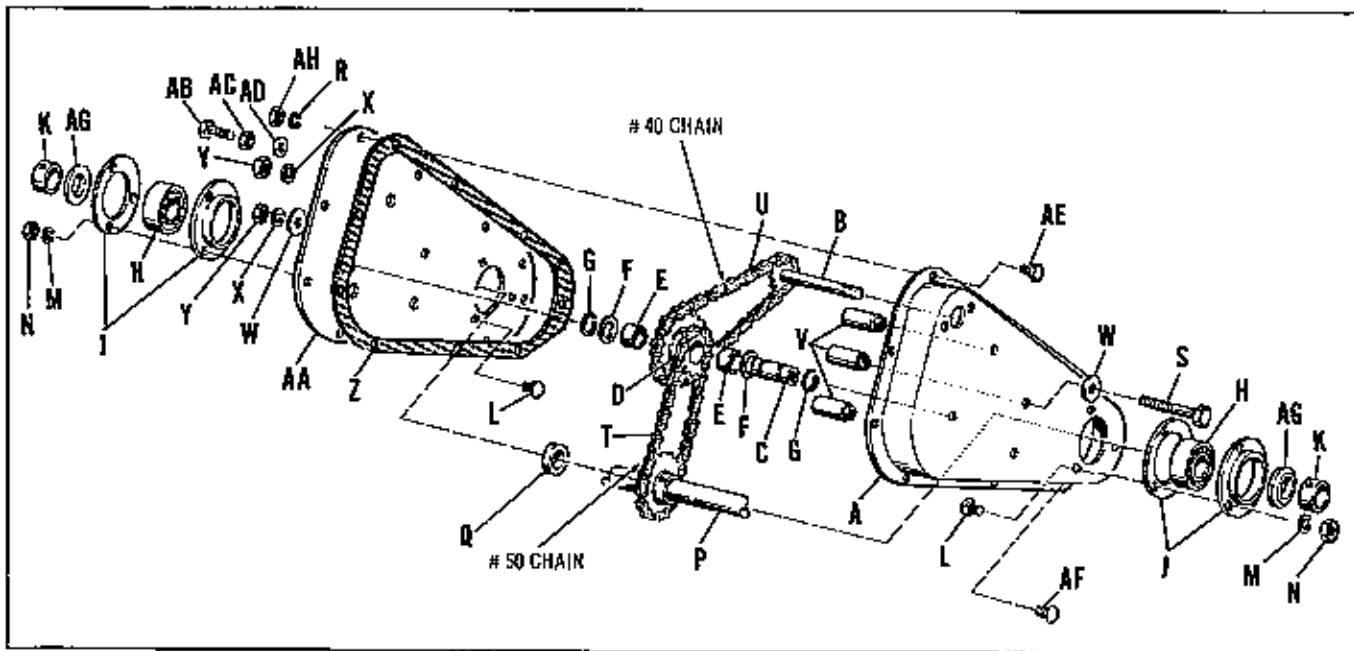

Ref. Let.	Part No.	Description
A	105123	Guard Assembly, Chain
B	105189	Shaft Assembly Drive
C	105192	Spacer, Intermediate
D	105193	Sprocket Assembly
E	105195	Bearing, Roller
F	8281014	Washer
G	105194	Ring, Retaining
H	8151071	Bearing
J	8151072	Flange, Bearing
K	8151073	Coilar, Bearing
L	702003	Bolt, Carriage, 3/8"-16 NC x 3/4" Ig.
M	720002	Washer, Lock 3/8"
N	717003	Nut, Hex, Full 3/8"-16 NC
P	105267	Tine Shaft Assembly
Q	105272	Spacer
R	720001	Washer, Lock 5/16"

Ref. Let.	Part No.	Description
S	715063	Capscrew, Hex, 7/16"-14 NC x 3-3/4" Ig.
T	8151015	Chain, Rotor
U	105055	Chain, Drive
V	105025	Spacer, Guard
W	105250	Washer
X	720006	Washer, Lock 7/16"
Y	717022	Nut, Hex, Full 7/16"-14 NC
Z	105016	Gasket
AA	105229	Plate Assembly
AB	715052	Capscrew, Hex, 3/8"-24 NF x 2-1/2" Ig.
AC	717014	Nut, Hex, Jam, 3/8"-24 NF
AD	8181199	Washer, Plain 3/8"
AE	705012	Capscrew, Hex, 5/16"-18 NC x 5/8" Ig.
AF	703005	Carriage, Bolt 5/16"-18 NC x 3/4" Ig.
AG	105237	Shield
AH	717511	Nut, Hex, Full 5/16"-18 NC

HITCH GROUP

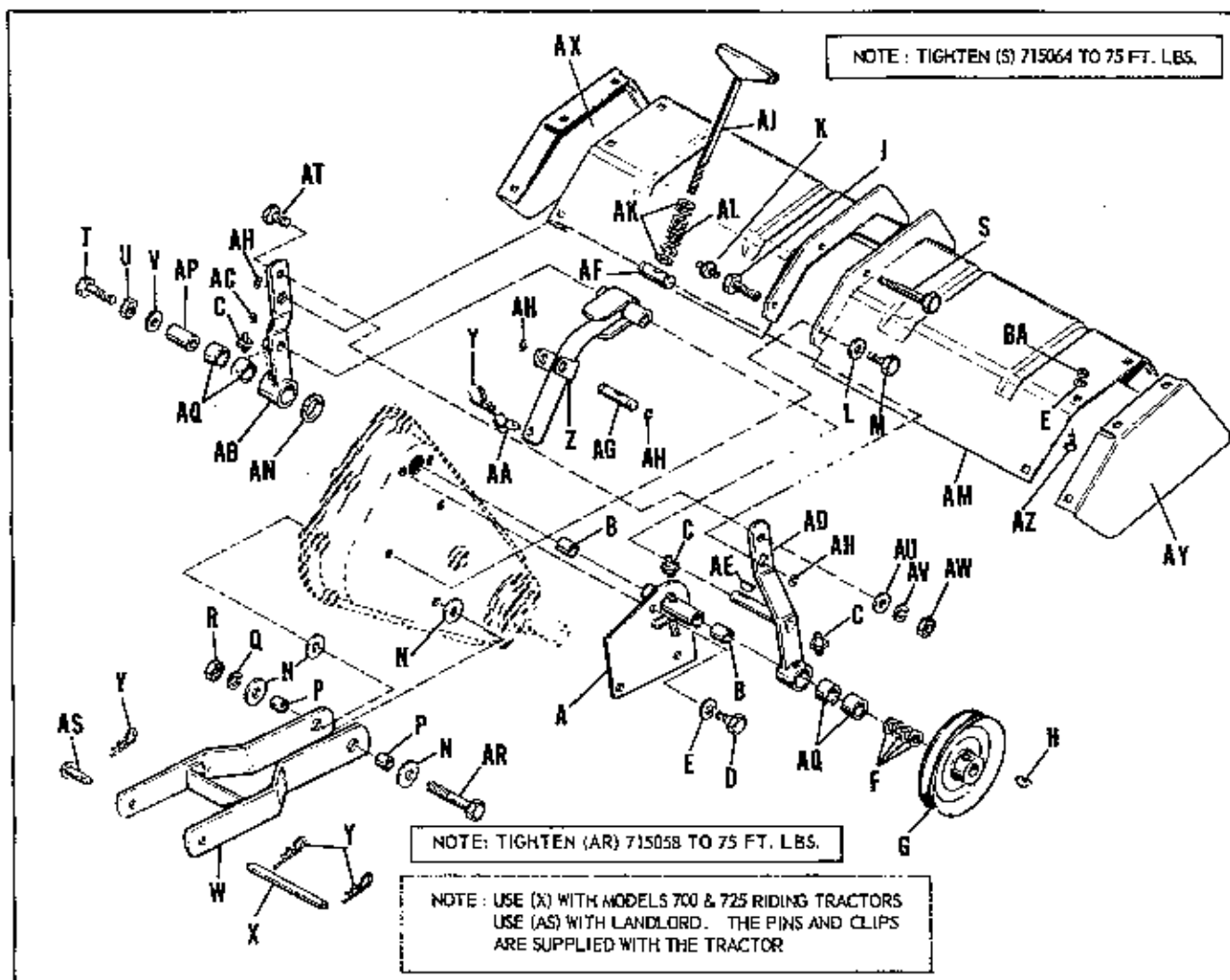

Ref. Let.	Part No.	Description
A	105127	Support Assembly, Brg. Hsg.
B	108054	Bearing, Needle
C	727001	Fitting, Grease
D	705017	Capscrew, Hex, 5/16"-18 NC x 3/4" lg.
E	720001	Washer, Lock 5/16"
F	153079	Washer
G	105191	Pulley, Drive
H	725003	Key, Woodruff
J	105132	Bolt
K	727002	Fitting, Grease
L	719003	Washer, Plain, 7/16"
M	706012	Capscrew, Hex, 1/2"-20 NF x 1-3/4" lg.
N	105250	Washer
P	105133	Spacer
Q	720006	Washer, Lock 7/16"
R	717022	Nut, Hex, Full 7/16"-14 NC
S	715064	Capscrew 7/16"-14 NC x 4" lg.
T	715052	Capscrew 3/8"-24 NF x 2-1/2" lg.
U	717014	Nut, Hex, Jam-3/8"-24 NF
V	8161199	Washer, Plain, 3/8"
W	105137	Frame Assembly
X	105140	Rod, Pivot
Y	8161045	Clip, Spring
Z	105141	Bar, Assembly, Lift
AA	118053	Pin

Ref. Let.	Part No.	Description
AB	105251	Lever Assembly, R.H. Belt Tension
AC	713503	Screw, Set, Cup Pr., Socket Hd. 5/16"-18 NC x 2/16" lg.
AD	105253	Lever Assembly, L.H. Belt Tension
AE	725002	Key Woodruff #6
AF	105153	Pivot, Upper
AG	105154	Pivot, Lower
AH	154264	Ring, Retaining
AJ	108415	Screw Assembly, Adjusting
AK	719001	Washer Plain 3/8"
AL	8191047	Spring
AM	105270	Deflector Assembly
AN	105238	Washer Thrust
AP	105236	Adapter
AQ	105058	Bushing
AR	715058	Capscrew Hex, 7/16"-14 NC x 4-1/2" lg.
AS	155037	Pin
AT	705005	Capscrew, Hex, 3/8"-16 x 1" lg.
AU	719001	Washer, Plain 3/8"
AV	720002	Washer, Lock 3/8"
AW	717003	Nut, Hex, Full, 3/8"-16
AX	105274	End Plate RH
AY	105273	End Plate LH
AZ	703011	Bolt Carriage 5/16"-18x1/2" lg.
BA	717001	Nut Hex. Full 5/16"-18

TILLER DRIVE

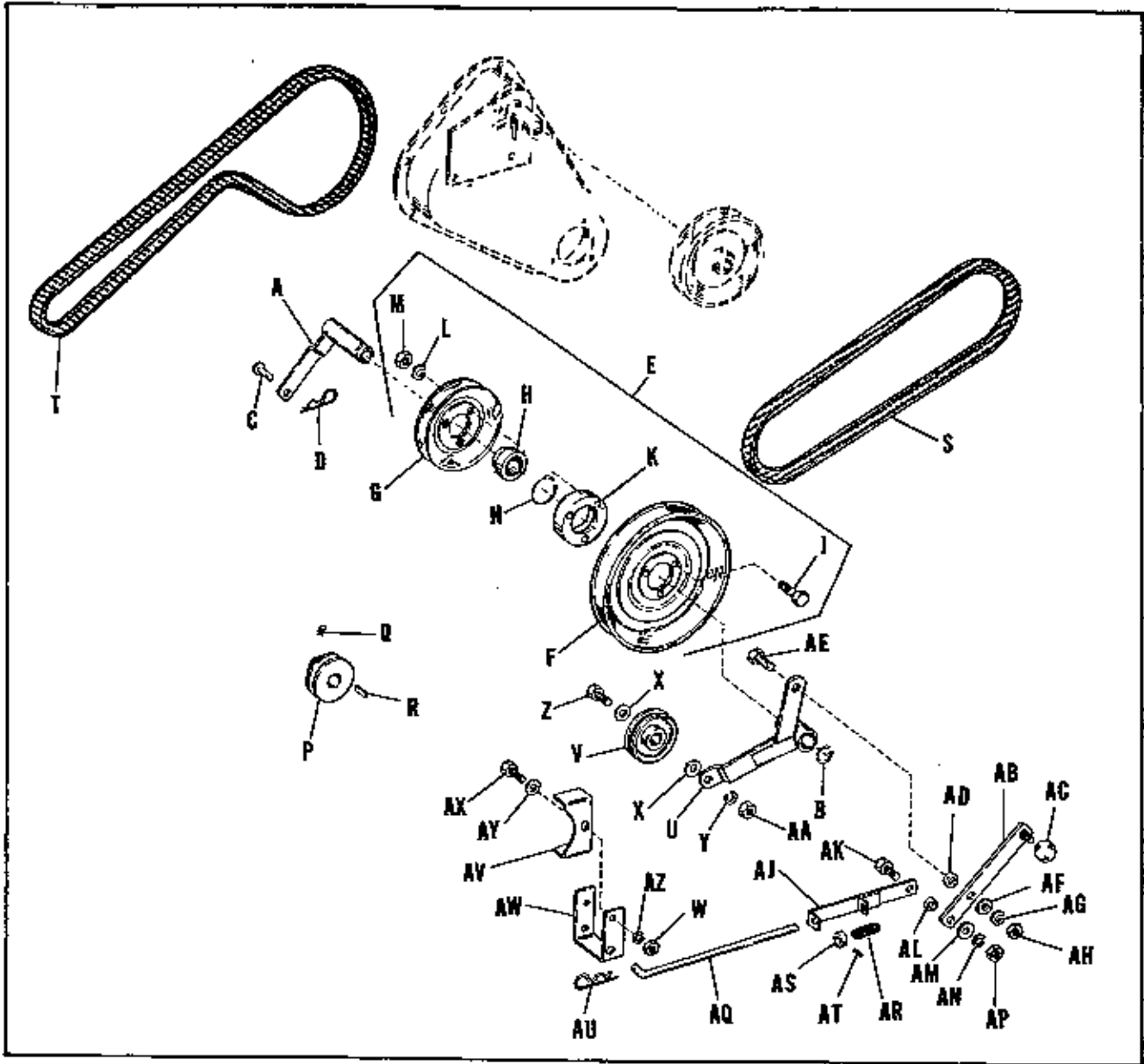

TRANSMISSION DRIVE

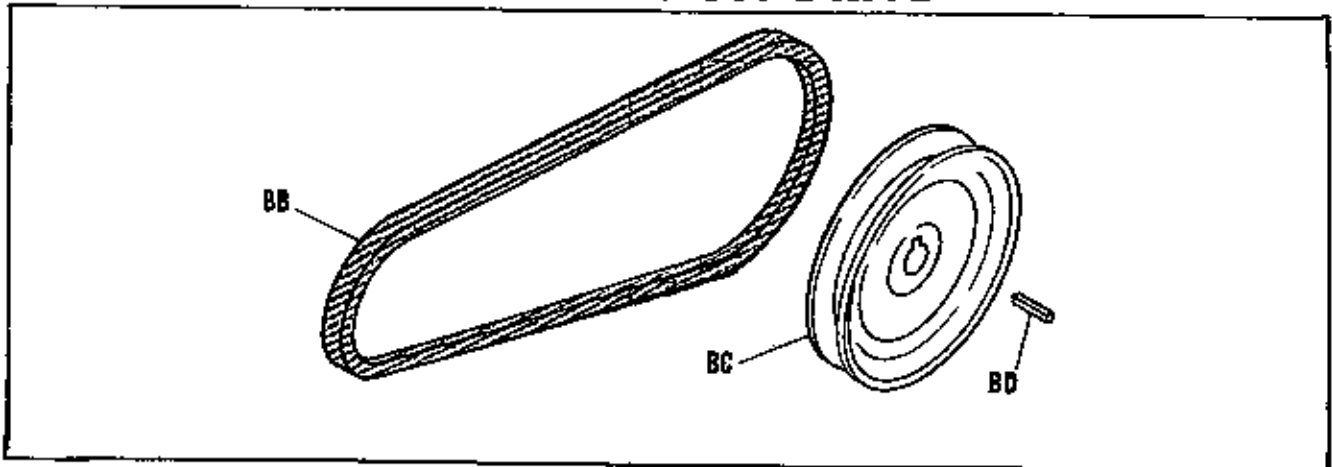

TILLER DRIVE

Reference Letter	Part No.	Description
A	105166	Sleeve Assembly, Pulley
B	105169	Ring, Snap
C	153058	Pin
D	8161045	Clip, Spring
E	105170	Pulley Assembly
F	105171	Pulley, 10"
G	105172	Pulley, 5 1/2"
H	105173	Bearing
J	705023	Capscrew, Hex., 5/16"-18 NC x 1 3/4" lg.
K	105174	Ring
L	720001	Washer, Lock, 5/16"
M	717001	Nut, Hex, Full, 5/16"-18 NC
N	105175	Ring, Snap
P	105176	Pulley, Tiller Drive
Q	713503	Screw, Set, Cup Point, Socket Head, 5/16"-18 NC x 5/16" lg.
R	8051081	Key
S	154273	Belt, "V"
T	105122	Belt, "V"
U	105177	Lever Assembly, Idler
V	108386	Pulley, Idler
W	717003	Nut, Hex, Full, 3/8"-16 NC
X	719002	Washer, Plain, 5/16"
Y	720002	Washer, Lock, 3/8"
Z	705016	Capscrew, Hex, 3/8"-16 NC x 1 1/4" lg.
AA	717003	Nut, Hex, Full, 3/8"-16 NC
AB	105182	Lever Assembly, Clutch
AC	122005	Knob
AD	105184	Spacer
AE	705005	Capscrew, Hex, 3/8"-16 NC x 1" lg.
AF	719001	Washer, Plain, 3/8"
AG	720002	Washer, Lock, 3/8"
AH	717003	Nut, Hex, Full, 3/8"-16 NC
AJ	8081503	Guide Assembly
AK	705031	Capscrew, Hex, 3/8"-16 NC x 7/8" lg.
AL	105184	Spacer
AM	719001	Washer, Plain, 3/8"
AN	720002	Washer, Lock, 3/8"
AP	717003	Nut, Hex, Full, 3/8"-16 NC
AQ	105185	Rod
AR	8191045	Spring
AS	8191022	Collar, Set
AT	713001	Screw, Set, Square Head, Cup Point, 1/4"-20 NC x 3/8" lg.
AU	8161045	Clip, Spring
AV	105186	Release, Belt
AW	105187	Bracket, Belt Release
AX	705031	Capscrew, Hex, 3/8"-16 NC x 7/8" lg.
AY	719001	Washer, Plain, 3/8"
AZ	720002	Washer, Lock, 3/8"

TRANSMISSION DRIVE

Reference Letter	Part No.	Description
BB	152017	Belt, "V"
BC	105188	Pulley, Drive
BD	8061081	Key

TINE ASSEMBLY

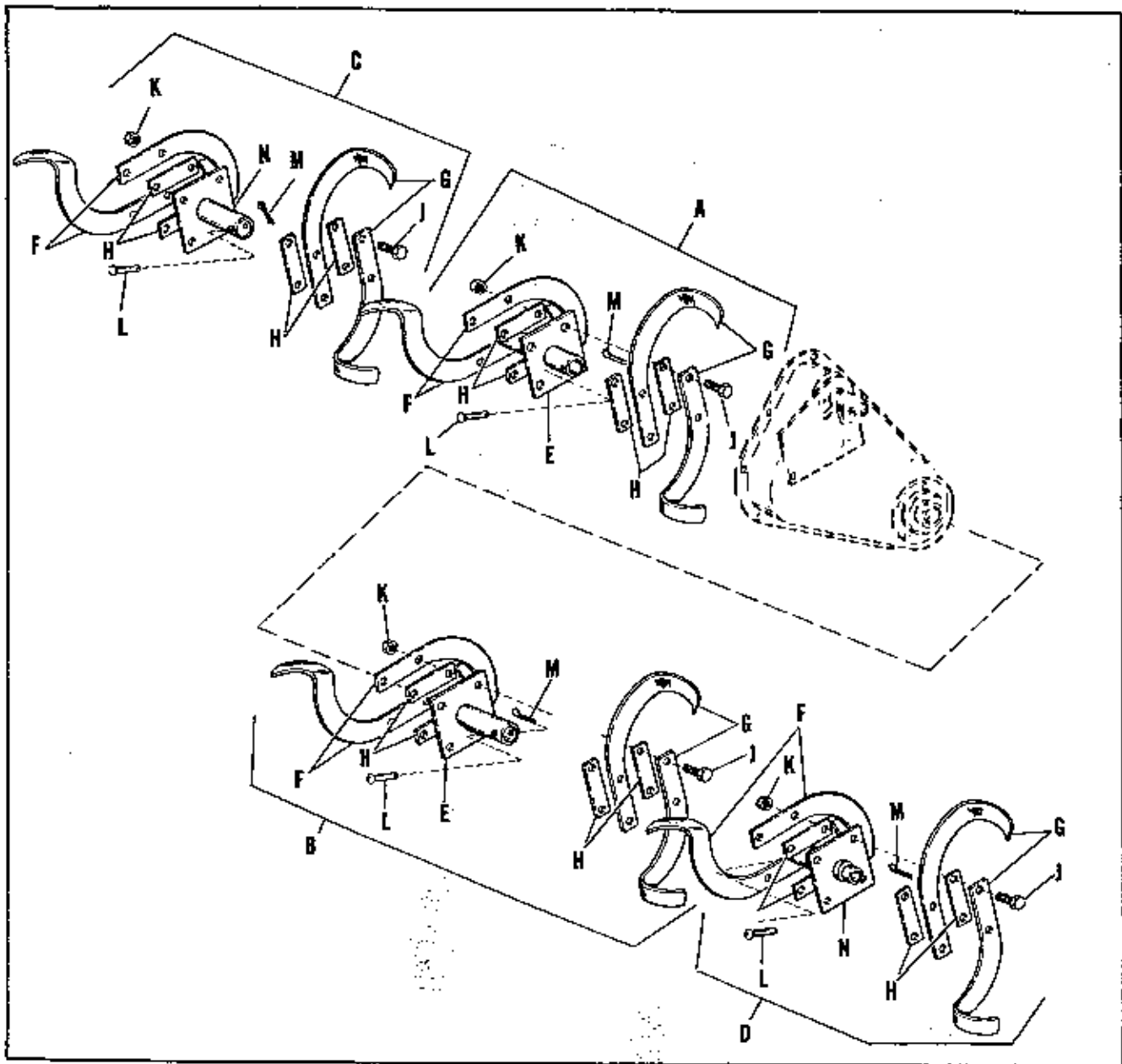

Reference Letter	Part No.	Description
A	105159	Blade Assembly, Right Hand Inner Tine
B	105163	Blade Assembly, Left Hand Inner Tine
C	105164	Blade Assembly, Right Hand Outer Tine
D	105165	Blade Assembly, Left Hand Outer Tine
E	105248	Plate Assembly, Tine, Inner
F	8152002	Blade, Tine, Right Hand
G	8152001	Blade, Tine Left Hand
H	105162	Spacer
I	706014	Capscrew, Hex, 7/16"-20 NC x 1 3/4" lg
K	717512	Nut, Lock, Hex, Full, 7/16"-20 NC
L	105249	Pin, Tine Shaft
M	722009	Pin, Cotter, 1/8" diameter
N	105245	Plate Assembly, Tine, Outer