

# How to use this file...(Operators Manuals)

---

## Instructions for **Print Vendors (Paper Manuals)**

- Paper Size:**
- \* 11 x 17
  - \* Body—50 lbs brilliant white offset or equivalent.
  - \* Cover—on pre-printed two-tone “Swash” stock.
- Press:**
- \* Body—1-color, 2-sided
  - \* Cover imprint —1-color, 1-sided
- Bindery:**
- \* Saddle Stitch, Face Trim
  - \* Face Trim
- COVERS:**
- \* **This file may contain several manuals, which differ only in their covers.**
  - \* Covers are all present at the beginning of this file.
  - \* Back cover for a particular manual is the page IMMEDIATELY AFTER the front cover.
  - Check the front cover for the individual part number (typically a 171xxxx number).
- BODY:**
- **The body of the manual is identical, regardless of the cover used.**
  - \* REMEMBER: ODD number pages are ALWAYS right hand pages, and EVEN number are ALWAYS left hand pages.
- General:**
- \* **This instruction page is NOT part of the manual and must NOT be printed.**
  - Pages labeled with the text “THIS PAGE INTENTIONALLY BLANK” are placement pages ONLY, and should NOT be printed.
-

THIS PAGE INTENTIONALLY BLANK



# OPERATOR'S MANUAL



## Rear Tine Tiller

### 5HP Rear Tine Tiller

Mfg. No.	Description
1693705	5HP Rear Tine Tiller

### 6HP Rear Tine Tiller

Mfg. No.	Description
1693704	6HP Rear Tine Tiller

1722191

Rev 12/1999

TP 100-2628-00-RT-S



Simplicity Manufacturing, Inc.  
500 N. Spring Street • P.O. Box 997  
Port Washington, Wisconsin 53074-0997

# Table Of Contents

<b>TABLE OF CONTENTS</b> .....	1	<b>TIPS</b> .....	15
<b>OPERATION SAFETY</b> .....	2	Tilling Tips .....	15
Owner's Responsibility .....	2	Cultivating Tips .....	15
Cautions and Important Notes .....	2	<b>MAINTENANCE AND STORAGE</b> .....	16
Important Safety Instructions .....	2	Check Forward Belt Tension .....	16
<b>SAFETY SIGNS &amp; DECALS</b> .....	4	Change Forward/Reverse Belt .....	17
Safety Decals .....	4	Check or Fill Engine Crankcase .....	18
<b>FEATURES</b> .....	5	Check Tiller Transmission Grease .....	19
<b>CONTROLS</b> .....	6	Check Tire Pressure .....	19
Drive Control Levers .....	6	Lubrication .....	19
Reverse Handle .....	7	Engine Maintenance .....	20
Engine Controls .....	8	Clean Tine Axle Shaft .....	20
<b>ADJUSTMENTS</b> .....	9	Prepare for Storage .....	21
Wheel Lockouts .....	9	Tiller and Engine Maintenance Schedule .....	21
Handlebar Adjustments .....	10	<b>TROUBLESHOOTING AND REPAIR</b> .....	22
Drag Stake .....	11	Troubleshooting Guide .....	22
Belt Tension Adjustment .....	11	<b>SPECIFICATIONS</b> .....	24
<b>OPERATION</b> .....	12	Features .....	24
Pre-Start Inspection .....	12	Technical Manual Availability .....	24
Starting and Stopping the Engine .....	13		
Tilling .....	14		

**CAUTION**

You must read, understand and comply with all safety and operating instructions in this manual before attempting to setup and operate this equipment.

Failure to comply with all safety and operating instructions can result in loss of machine control, serious personal injury to you and/or bystanders, and risk of equipment and property damage. The triangle in the text signifies important cautions or warnings which must be followed.

**CAUTION**

Engine exhaust from this product contains chemicals known, in certain quantities, to cause cancer, birth defects, or other reproductive harm.

**For easy reference, please record the information on the chart below.**

The Rototiller Reference Data can be found on the identification tag located on the unit's left engine mount. *(Refer to the Engine Owner's Manual for location of engine information serial number.)*

ROTOTILLER REFERENCE DATA	
Model Description/Number	
M/N (Manufacturer's Number)	S/N (Serial Number)
Dealer Name	Date Purchased
ENGINE REFERENCE DATA	
Engine Make/Model	Engine ID/Serial Number

# Operation Safety

## SECTION CHECKLIST

Owner's Responsibility

Cautions and Important Notes

Important Safety Instructions

## OWNER'S RESPONSIBILITY

*Safe and effective use of the rototiller is the owner's responsibility.*

1. Read and follow all safety instructions.
2. Maintain the tiller according to directions and schedule included.
3. Ensure that anyone who uses the tiller is familiar with all controls and safety precautions.

## CAUTIONS AND IMPORTANT NOTES

Two symbols which draw attention to information of special importance appear throughout this manual. These comments range in importance from helpful hints to warnings about risk of personal injury. Please take the time to read and understand them.



**Indicates a situation which may cause personal injury. It means - attention! Become alert! Your safety is involved.**



**Provides helpful information for proper assembly, operation, or maintenance of your rototiller.**

**Please read this section carefully.** Operate the tiller according to the safety instructions and recommendations outlined here and inserted throughout the text. Make sure anyone who uses the tiller has read the instructions and is familiar with the controls.

## IMPORTANT SAFETY INSTRUCTIONS

### GENERAL

- **CAREFULLY READ THIS MANUAL AND FOLLOW ALL INSTRUCTIONS.**
- Be familiar with all controls before operating the tiller. Your tiller is equipped with a safety device that enables you to stop the wheels and tines quickly in an emergency. Learn how the drive control levers work and how to control the tiller at all times.
- Never allow children to operate the tiller. Keep small children away from the area being tilled. Do not allow adults to operate the tiller without proper instruction.



The right and left sides of your rototiller are determined from the operating position as you face the direction of forward travel.

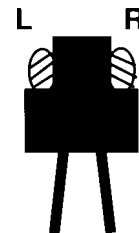

### PREPARATION

- Dress appropriately when operating the tiller. Always wear sturdy footwear. Never wear sandals, sneakers, or open shoes, and never operate the tiller with bare feet. Do not wear loose clothing that might get caught in moving parts.
- Carefully inspect the area to be tilled, and remove all foreign objects. Do not till above underground water lines, gas lines, electric cables, or pipes. Do not operate the tiller in soil with large rocks and foreign objects which can damage the equipment.
- Disengage all clutches and shift into neutral before starting the engine.
- Handle fuel with care; it is highly flammable.
  - a. Use an approved fuel container.
  - b. Never add fuel to a running engine or hot engine.
  - c. Fill fuel tank outdoors with extreme care. Never fill fuel tank indoors.
  - d. Replace gasoline cap securely and clean up spilled fuel before restarting.
- Never attempt to make any adjustments while the engine is running.

## OPERATION

- Never operate the tiller without guards, covers, and hoods in place.
- Never start the engine or operate the tiller with the wheels in the free-wheel position. Make sure the wheel lockouts are engaged through wheel hubs and wheel axle. The wheels act as a brake to keep the tiller at a controlled speed. Disengage wheel lockouts to permit free-wheeling only when engine is stopped.
- Keep hands, feet, and clothing away from rotating parts. Keep clear of tiller tines at all times.
- Tines and wheels rotate when tiller is engaged in **forward** or **reverse**— in **forward**, tines and wheels rotate when the drive control levers are pulled down; in **reverse**, wheels and tines rotate when the reverse handle is pulled back towards the operator. Releasing the drive control levers to **neutral** stops the wheels and tines.
- Be extremely cautious when operating in **reverse**. Take extra care to avoid slipping or falling, and to keep feet clear of tines.
- Exercise extreme caution when operating on or crossing gravel drives, walks, or roads. Stay alert for hidden hazards or traffic.
- After striking a foreign object, stop the engine, remove the wire from the spark plug, thoroughly inspect the tiller for any damage, and repair the damage before restarting and operating the tiller.
- If vegetation clogs the tines, raise the handlebars to elevate the tines, and run the tiller in **reverse**. If this does not clean clogged vegetation from the tines, **STOP THE ENGINE AND DISCONNECT THE SPARK PLUG WIRE** before removing vegetation by hand.
- Engine muffler will be hot from operation. Do not touch it with bare skin or a severe burn may result.
- If the unit should start to vibrate abnormally, stop the engine and check immediately for the cause. Vibration is generally a warning of trouble.
- Do not run the engine indoors; exhaust fumes are dangerous.
- Do not overload the machine capacity by attempting to till too deep at too fast a rate.
- Never operate the machine at high transport speeds on slippery surfaces. Look behind and use care when backing.

- Never allow bystanders near the unit.
- Use only attachments and accessories approved by the manufacturer of the tiller.
- Never operate the tiller without good visibility or light.
- Be careful when tilling in hard ground. The tines may catch in the ground and propel the tiller forward. If this occurs, let go of the handlebars and do not restrain the machine.
- Take all possible precautions when leaving the machine unattended. Disengage all controls levers, stop the engine, wait for all moving parts to stop, and make certain guards and shields are in place.
- When leaving the operating position for any reason:
  - shut off the engine.
  - wait for all moving parts to stop.

## MAINTENANCE AND STORAGE

- Keep machine, attachments, and accessories in safe working condition.
- Check shear bolts, engine mounting bolts, and other bolts at frequent intervals for proper tightness to be sure the equipment is in safe working condition.
- To prevent accidental starting, always disconnect the spark plug wire from the spark plug before performing tiller maintenance.
- Never run the engine indoors. Exhaust fumes are deadly.
- Always allow muffler to cool before filling fuel tank.
- Never store equipment with gasoline in the tank inside a closed building where fumes may reach an open flame or spark. Allow the engine to cool before storing in any building.
- Always refer to the operator's guide instructions for important details if the tiller is to be stored for an extended period.

# Safety Signs & Decals

## SAFETY DECALS

Safety warning decals are placed at strategic locations on the equipment as a constant reminder to the operator of the most important precautions. All warning, caution and instructional messages on your equipment should be carefully read and obeyed. If any of these decals are lost or damaged, replace them at once. They can be purchased from your local dealer.

<b>⚠ WARNING</b>	<b>⚠ WARNING</b>
<b>AVOID SERIOUS INJURY</b> <ul style="list-style-type: none"> <li>Read operator's manual(s) before operating.</li> <li>Know the location and function of all controls.</li> <li>Keep all shields and guards in place and working while running.</li> <li>Never allow children to operate tiller.</li> <li>Dress appropriately --- wear sturdy footwear.</li> <li>Carefully inspect area to be tilled --- remove large rocks and other foreign objects.</li> <li>Do NOT till above underground electric, water, gas, or other utility lines and pipes.</li> <li><b>STOP THE ENGINE AND DISCONNECT THE SPARK PLUG WIRE</b> before removing debris or servicing unit.</li> <li>When leaving the operating position for any reason:               <ul style="list-style-type: none"> <li>--- shut off the engine.</li> <li>--- wait for all moving parts to stop.</li> </ul> </li> </ul>	<b>WHEELS ACT AS BRAKES</b> <ul style="list-style-type: none"> <li>Never start or operate tiller with wheels in the Free-Wheel position. Make sure wheel lockouts are engaged through wheel hubs and axle.</li> <li>Wheels act as brakes to keep the tiller at a controlled speed. Disengage wheel lockouts <b>ONLY</b> when engine is stopped.</li> </ul>
<b>OPERATION</b>	
<b>REFER TO OPERATOR'S MANUAL FOR DETAILED OPERATING INSTRUCTIONS</b>	
<b>TO START:</b> <ol style="list-style-type: none"> <li>1. Release drive control levers to neutral position.</li> <li>2. Lower the drag stake so that tines do not touch the ground.</li> <li>3. Check position of wheels and wheel lockouts.</li> <li>4. Slide choke control to choke position.</li> <li>5. Move throttle control lever to fast position.</li> <li>6. Pull starter rope.</li> </ol>	
<small>LBL516AA</small>	

**Part No. 1716747**  
**OPERATING INSTRUCTIONS / Hood Decal**

**⚠ DANGER**



**AVOID INJURY FROM ROTATING TINES!**  
 Keep hands, feet, and clothing away.

- Tines rotate when tiller is engaged in forward or reverse.
- Tines and wheels rotate when drive control levers are pulled down.
- In reverse, tines and wheels rotate when the reverse handle is pulled back toward the operator.
- Releasing the drive control levers to neutral stops the wheels and tines.**

LBL516E

**Part No. 1716840**  
**TINES DANGER / Hood Flap Decal**

**⚠ WARNING!**

DO NOT START ENGINE UNLESS BELT COVER IS ATTACHED. KEEP HANDS, FEET, AND CLOTHING AWAY FROM MOVING BELTS AND PULLEYS. FAILURE TO COMPLY COULD RESULT IN INJURY. SEE OWNER'S MANUAL FOR FULL SAFETY INSTRUCTIONS.

LBL516C

**Part No. 1716800**  
**WARNING / Belt Cover Decal**

PLACE FREE  
HAND HERE

LBL516F

**Part No. 1716839**  
**FREE HAND / Bumper Guard Decal**



**MODEL 616RT**

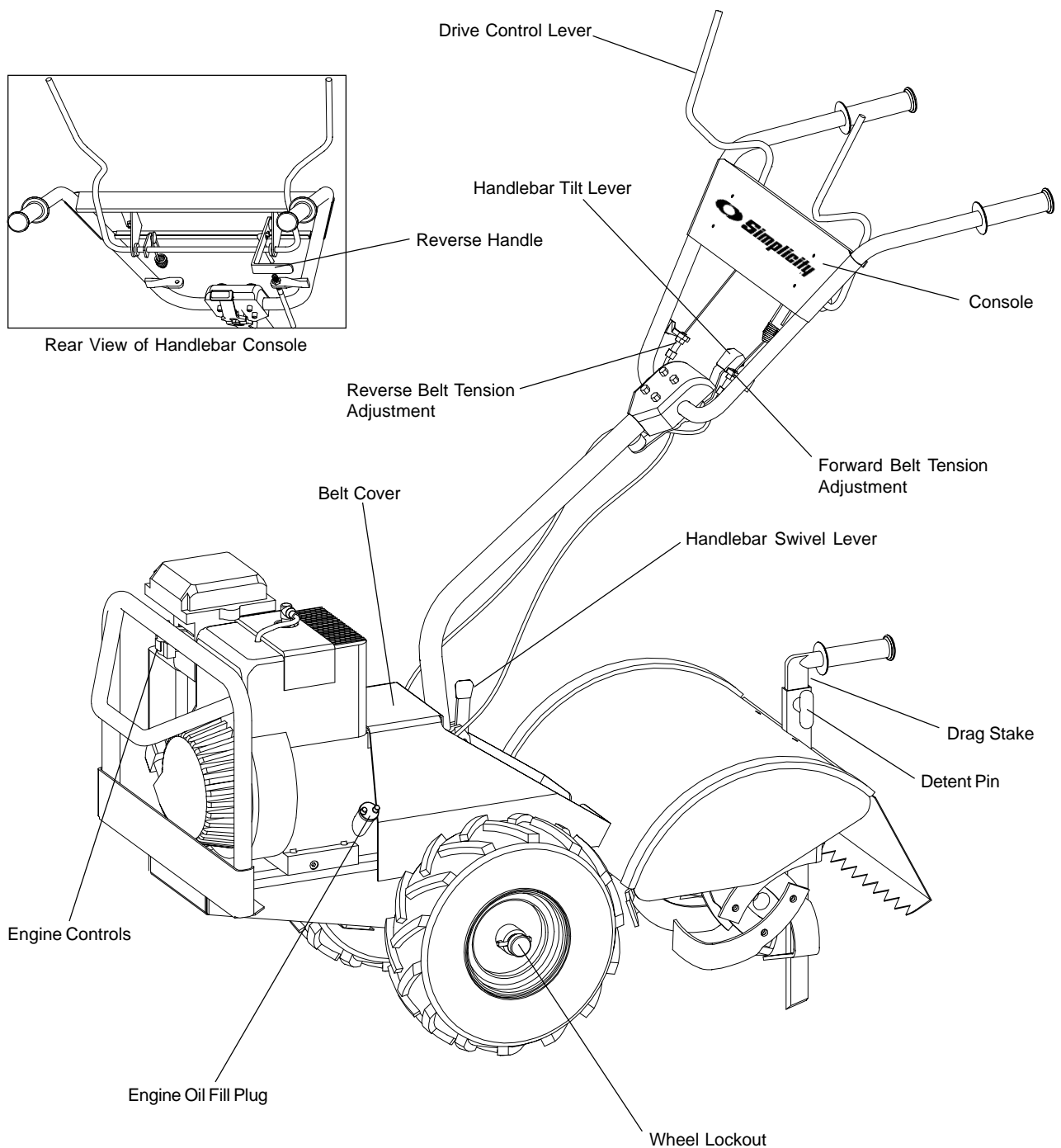

# Controls

---

## SECTION CHECKLIST

Drive Control Levers

Reverse Handle

Engine Controls

## DRIVE CONTROL LEVERS

*Engage wheels and tines into forward, releasing returns machine to neutral.*

Pulling down on drive control levers engages the wheels and tines. Releasing drive control levers disengages the wheels and brings the tiller to a complete stop. It is now in the neutral position.

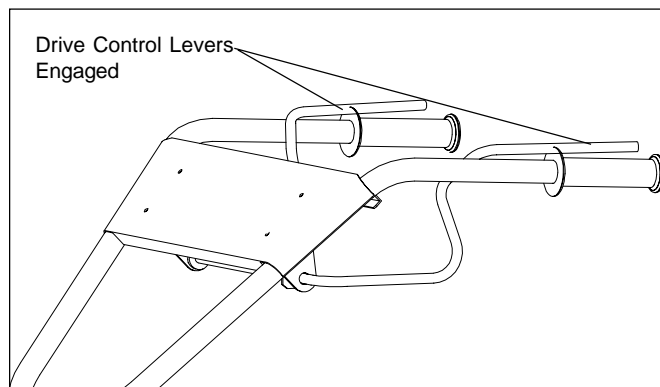

### CAUTION

This information is provided here only to introduce the controls. **DO NOT START THE ENGINE AT THIS TIME.** Starting and operating instructions are given on page 13. Please read this section and all operating and safety instructions before starting your tiller.

### CAUTION

**ENGINE SHOULD BE OFF BEFORE ADJUSTING ANY CONTROLS!**

### IMPORTANT

- ❖ As a safety precaution, the drive control levers will not lock in the forward position.
- ❖ To stop the wheels and tines at any time, release the drive control levers.

## REVERSE HANDLE (616RT)

*Engages wheels and tines in reverse.*

Pulling reverse handle back towards operator reverses tiller.

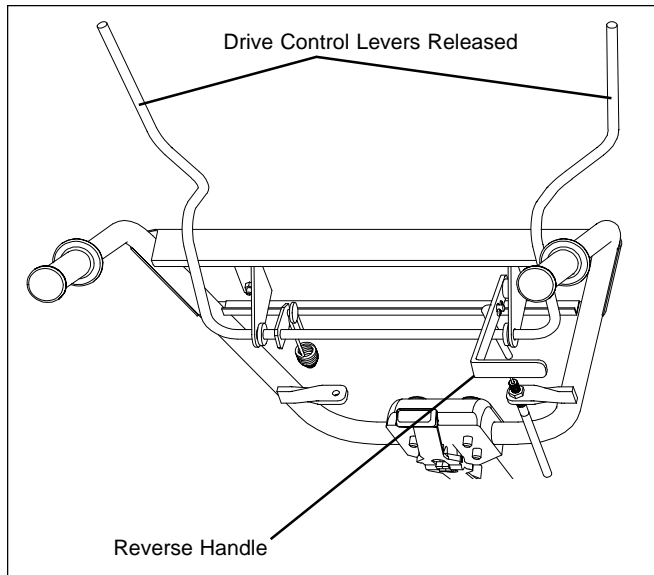

### CAUTION

Extreme caution should be used when operating rototiller in the reverse direction.

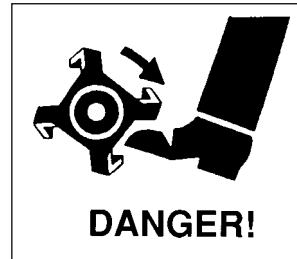

### IMPORTANT

- ❖ As a safety precaution, the reverse handle will not lock in reverse.
- ❖ To stop the wheels and tines at any time, release the reverse handle.
- ❖ Do not operate both the reverse handle and drive control levers at the same time.

# Controls

## ENGINE CONTROLS

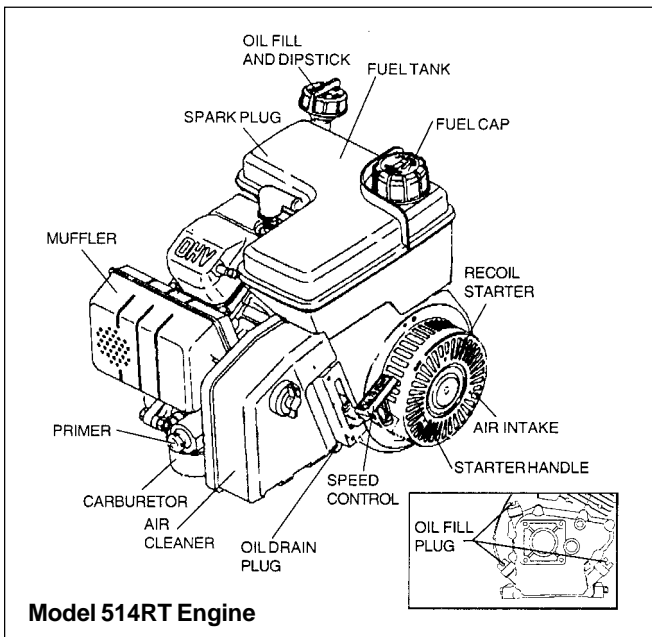

### Throttle Control

Move throttle control to fast position to start and run the engine. To stop the engine, move to idle position, then to off.

### Choke Control

Put choke control in choke position if engine is cold. A warm engine requires less choking than a cold engine.

Refer to your engine manual for further information.

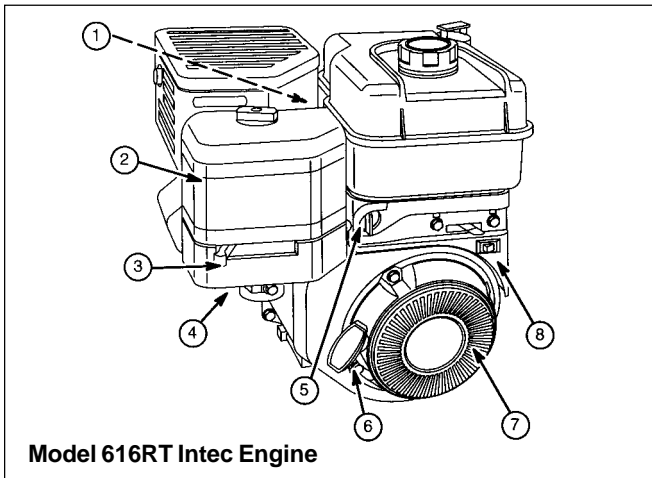

### Model 616RT

1. Spark plug wire
2. Air cleaner
3. Choke
4. Carburetor
5. Fuel shut-off valve (if equipped)
6. Rope handle
7. Finger guard
8. Stop switch (if equipped)
9. Fuel fill
10. Fuel tank
11. Oil fill/Dipstick (if equipped)
12. Blower housing
13. Oil drain plug
14. Oil fill cap
15. Engine Id plate
16. Muffler

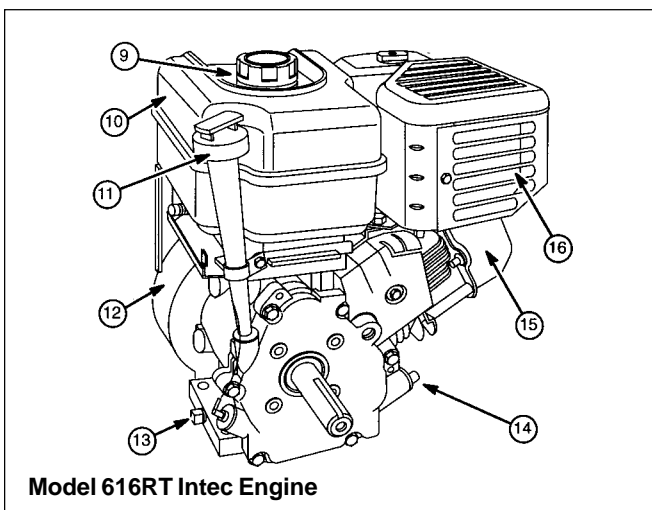

## SECTION CHECKLIST

Wheel Lockouts

Handlebar Adjustments (Tilt & Swivel)

Drag Stake

Belt Tension Adjustment

## WHEEL LOCKOUTS (616RT)

*Place wheels in tilling position.*

1. Pull knob in center of wheel out, away from machine.
2. Rotate knob and lockout to align with slot on axle, release knob. Rotate wheel to align slot in wheel hub with lockout.
3. Wheel and axle should be firmly locked together before tilling.
4. Repeat for other wheel.

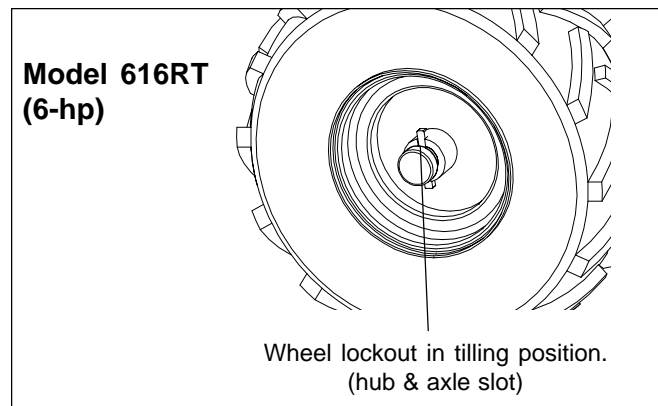

**NOTE: Always have both wheel lockouts in or out. Do not operate tiller with only one wheel locked.**

*To place wheels in free-wheel position.*

1. Pull knob in center of wheel out, away from machine .
2. Rotate knob and lockout to align lockout with detent in end of axle. Release knob.
3. Wheel should turn freely on axle.

## WHEEL LOCKOUTS (514RT)

*Place wheels in tilling position.*

1. Remove lockpin. Align hole in axle with hole in wheel hub.
2. Insert lockpin through holes, fold lockpin ring to secure pin to axle.
3. Wheel and axle should be firmly locked together before tilling.
4. Repeat for other wheel.

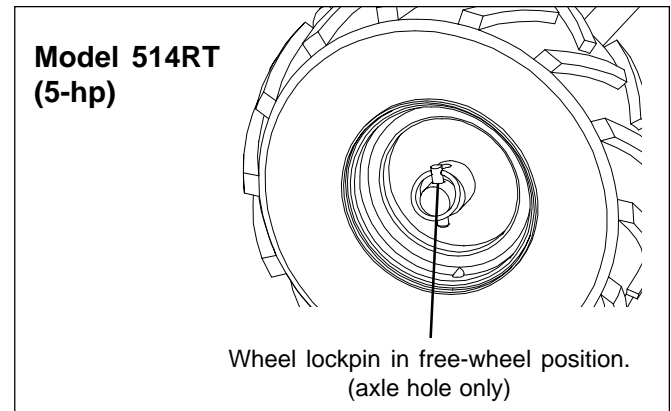

**NOTE: Always have both wheel lockouts in or out. Do not operate tiller with only one wheel locked.**

*To place wheels in free-wheel position.*

1. Remove lockpin. Slide wheel inward toward machine.
2. Insert pin in axle only.
3. Wheel should turn freely on axle.

 **CAUTION**

Never start engine or operate tiller with wheels in free-wheel position. The free-wheel position is for transporting the tiller long distances over level ground—do not attempt to move the tiller up or down steep grades in the free-wheel position.

# Adjustments

## HANDLEBAR ADJUSTMENTS (616RT)

Tilt handlebars up or down, swivel 30° left or right.

### To Tilt Up or Down:

1. Push down on handlebar tilt lever.
2. While holding tilt lever down, adjust handlebars to a comfortable height by moving up or down. There are 4 height positions.
3. Release handlebar tilt lever to lock.

### To Swivel 30° Left or Right:

1. Squeeze handlebar swivel lever towards handlebar stem.
2. While holding handlebar swivel lever in, rotate handlebar 30° left or right.
3. Handlebars will lock in place after handlebar swivel lever is released.

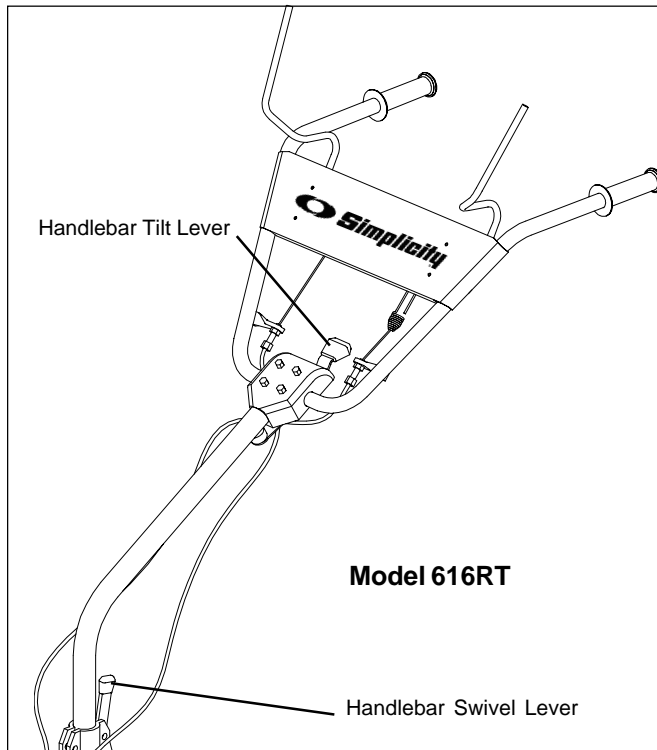

## HANDLEBAR ADJUSTMENTS (514RT)

Adjust handlebar height.

The ideal height of the handlebar varies with operator height and the depth of tilling. to adjust handlebar height:

1. Unscrew T-Clamp until handlebar moves freely up and down.
2. Align locator pin to desired hole in the height adjustment bracket by raising or lowering handlebars.
3. Retighten T-Clamp firmly.

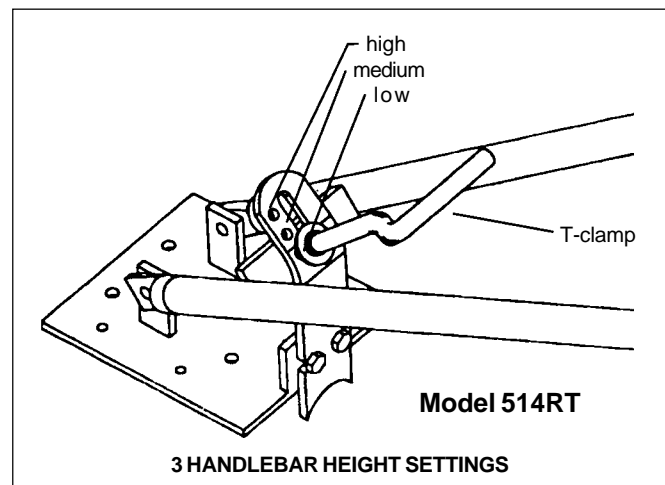

## DRAG STAKE

Tilling depth is controlled by the height of the drag stake.

To adjust tilling depth.

1. Remove detent pin.
2. Raise the drag stake to position tines at chosen tilling depth.
3. Align hole in drag stake with hole in depth regulator bracket and replace detent pin.

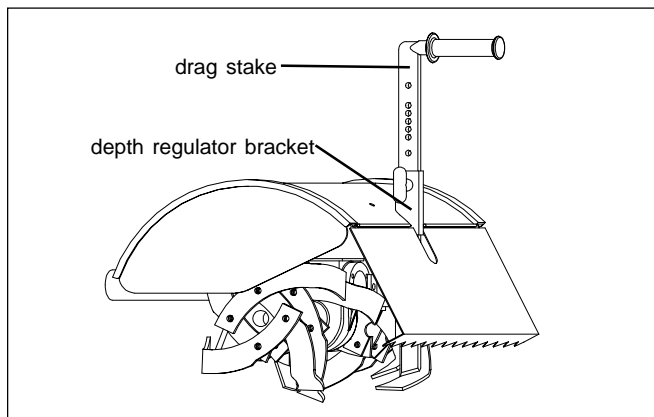

**Drag Stake Down** = Shallower tilling. Place the detent pin in the top hole of the drag stake for shallowest tilling.

**Drag Stake Up** = Deeper tilling. Place the detent pin in the bottom hole of the drag stake for deepest tilling.



### CAUTION

Always set the drag stake in the transport position before starting engine, that is, place the detent pin in the highest hole of the drag stake.



### CAUTION

Do not adjust tilling depth unless drive control levers are released to neutral position.

## BELT TENSION ADJUSTMENT

Proper belt tension is critical to good performance. After 1/2 hour of operation, all cables may have to be adjusted due to initial stretch. Thereafter, check tension after every 2 hours of operation.

### **To increase belt tension:**

1. Loosen upper jam nut. Turn nut up cable in 1/8" increments.

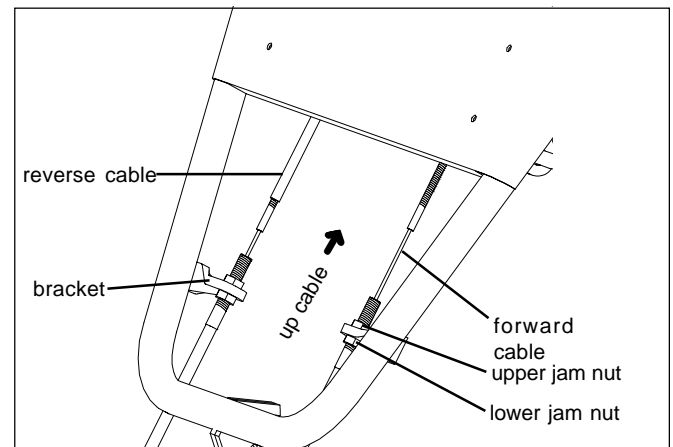

2. Tighten lower jam nut.

3. Check adjustment.

This procedure can be repeated until conduit adjustment bolts have no more adjustment left. If no more adjustment can be made, belt may have to be replaced.

**NOTE: Model 514RT has a forward cable only.**

# Operation

---

## SECTION CHECKLIST

Pre-Start Inspection

Starting and Stopping the Engine

Tilling

## PRE-START INSPECTION

1. Make sure all safety guards are in place and all nuts and bolts are secure.
2. Check oil level in engine crankcase. See your engine manual for procedure and specifications.
3. Inspect air cleaner for cleanliness. See your engine manual for procedure.
4. Check the fuel supply. Fill the fuel tank no closer than 1 inch from top of tank to provide space for expansion. See your engine manual for fuel recommendations.
5. Be sure spark plug wire is attached and spark plug is tightened securely.
6. Check position of wheels and wheel lockouts.
7. Check drag stake position.



### CAUTION

Please do not start your tiller until you have read the Manual that came with your engine, and the sections in this manual titled Controls, Adjustments and Safety. If you have read these, follow the steps below to start your tiller. Always perform this pre-start checklist before starting the engine.



### CAUTION

Gasoline is highly flammable and must be handled with care. Never fill the tank when the engine is hot or running. Always move outdoors to fill the tank.



### CAUTION

Wheels must always be locked in the TILLING position when engine is running. Do not operate the tiller with the wheel lockouts unlocked. Always set the wheels in tilling position before starting engine.



### CAUTION

Always put the drag stake in the transport position before starting engine. Tines should clear the ground.



Engine is shipped from factory without oil. **YOU MUST ADD ENGINE OIL BEFORE STARTING ENGINE.**



## STARTING AND STOPPING THE ENGINE

### ***To Start Engine:***

1. Drive control levers should be released to neutral position.
2. Turn fuel shut-off valve (if equipped) 1/4 turn to **open**.
3. Push choke lever to **choke** position.
4. Move throttle control lever to **fast** position.
5. Push rocker switch (if equipped) to **on**.
6. Pull start engine. Stand to the right of tiller engine, grasp rope handle and pull rope out, slowly, until it pulls slightly harder. Let rope rewind slowly. Then pull rope with a rapid full arm stroke. Let rope return to starter slowly. Let engine warm for a few minutes before beginning to operate.
7. When engine starts, operate in **fast** position.
8. Move choke lever toward **run** position.

**NOTE: If engine does not start after 3 pulls, check troubleshooting guide for suggestions.**

### ***To Stop Engine:***

1. Move throttle control to **slow** position. Then move to **stop** position.
2. Push rocker switch (if equipped) to **off**.
3. Close fuel shut-off valve (if equipped).

Refer to your engine manual for further information.



### **CAUTION**

Always keep hands and feet clear of rotating machine parts.



### **CAUTION**

Temperature of muffler and near by areas may exceed 150° F. Avoid these areas.



### **CAUTION**

Do not move choke lever to CHOKE to stop engine. Backfire or engine damage may occur.



To stop the engine at any time, move throttle control to the off position. To stop wheels and tines at any time, release drive control levers to neutral position.

# Operation

---

## TILLING

1. Adjust the drag stake to desired tilling depth.

**NOTE: Raise drag stake up one hole at a time, testing tiller operation after each raise. Raising drag stake too high can result in loss of control of tiller!**

2. Move the throttle control to *fast*.

3. Place the tiller in *forward* by pushing down on the drive control levers--this will engage the wheels and tines.

**NOTE: You can slow the tiller's forward advance at any time by putting slight downward pressure on the handlebars, or you can stop the tiller by releasing the drive control levers to the neutral position.**



### CAUTION

To stop wheels and tines at any time, release drive control levers to neutral position.



### CAUTION

Always release drive control levers to neutral position before adjusting the drag stake.

### IMPORTANT

Practice operating the controls and tiller with tines out of ground before beginning to till. It is important that you know how to use the tiller properly, how to keep control at all times, how to stop the tines and wheels from turning, and how to stop the engine if necessary. If you do not know how to do these things, read the Controls, Adjustments and Safety sections before proceeding.

## TILLING TIPS

*The key to successful tilling is to begin with a shallow cut on the first pass, and then work an inch or two deeper on each successive pass.*

- ★ Tilling depth will vary with ground conditions.
- ★ When beginning to till in unbroken ground or in extremely hard soil, set the detent pin in the highest hole of the drag stake (follow instructions under Tilling on previous page). This will allow for shallow tilling. With the drag stake in this position, make several light passes over the area to be tilled. Reset for deeper depths with successive passes.
- ★ If tiller jumps or skids uncontrollably, lower the drag stake by placing the detent pin in a higher hole. This will allow for shallower tilling. Hold firmly to the handlebars to control sudden lurches.
- ★ If weeds, tall grasses, vines, or other materials clog or jam the tines, reverse the tiller to unwind vegetation.

*Immediately release the drive control levers if the tines jam or you strike a foreign object. With drive control levers in neutral, push throttle control to **stop** position to stop the engine. Disengage the spark plug wire. When tines have stopped, remove foreign objects and check for damage.*

## CULTIVATING TIPS

If you plan to use your tiller for cultivating:

- ★ Plant rows on 20" - 22" centers for ease of turning.
- ★ Set the drag stake with the detent pin in one of the higher holes. This will allow the shallow cultivation necessary to turn over weeds, and break up and aerate the soil.



### CAUTION

Extreme caution must be taken in selecting tilling depth. If you attempt to till too deeply for soil conditions, that is, with the drag stake in too high a position, loss of control could result.



### CAUTION

If removing material from the tines by hand, stop engine and remove spark plug wire first.

# Maintenance and Storage

## SECTION CHECKLIST

- Check Forward Belt Tension
- Change Forward/Reverse Belt
- Check or Fill Engine Crankcase
- Check Tiller Transmission Grease
- Check Tire Pressure
- Lubrication
- Engine Maintenance
- Clean Tine Axle Shaft
- Prepare for Storage
- Tiller and Engine Maintenance Schedule

## CHECK FORWARD BELT TENSION

Forward belt tension may decrease over time. It must be adjusted within the first half hour of operation, and checked after every two hours of operation. Proper adjustment will assure long belt life. Too much or too little belt tension will cause premature belt failure. To check and adjust the forward belt tension:

1. Turn off engine. Engine must be cool.
2. Remove spark plug wire from spark plug.
3. With drive control levers in neutral position, measure length of spring when compressed.
4. Pull down on drive control levers and remeasure length of spring when stretched out. Ideal length would be 1/4" longer.

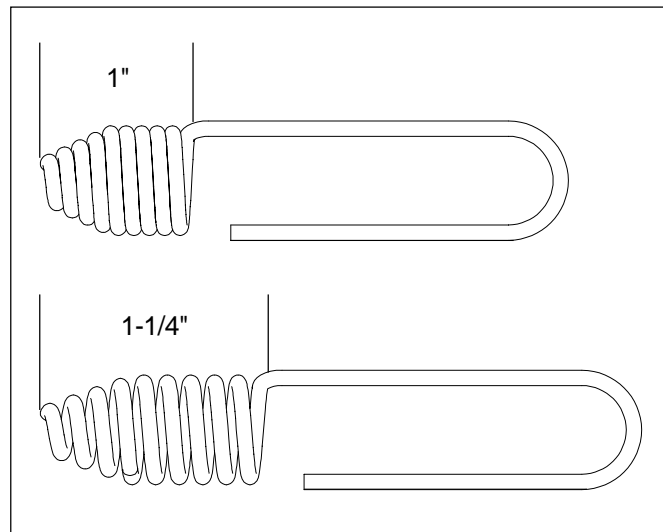
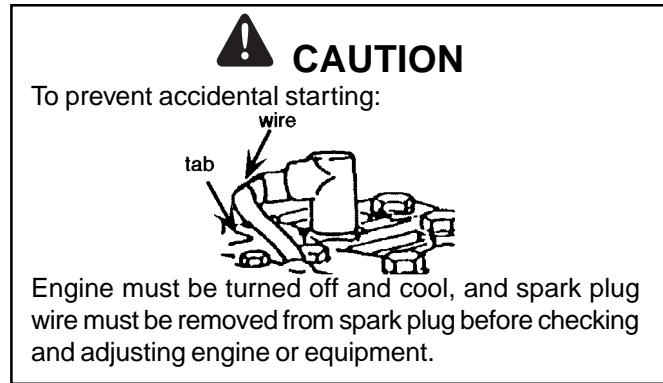

## CHANGE FORWARD/REVERSE BELT

**NOTE: Change reverse belt on Model 616RT only.**

1. Turn off engine. Engine must be cool.
2. Remove spark plug wire from spark plug.
3. Remove belt guard.
  - ★ remove the forward belt from the forward engine pulley:
    - gently pull the engine recoil rope to rotate the pulley.
    - with the pulley turning, force the forward belt out of the V-groove.
    - slide the belt free of the engine pulley.
    - pull the forward belt down and out of the way.
  - ★ remove the reverse belt from the reverse engine pulley:
    - gently pull the engine recoil rope to rotate the pulley.
    - with the pulley turning, force the reverse belt out of the V-groove.
    - slide the belt free of engine pulleys and reverse belt guides.
    - pull belt down and away from transmission pulley.
  - ★ install new reverse belt:
    - thread belt up from bottom.
    - place belt around transmission pulley in groove.
    - place belt under reverse belt guides.
    - gently pull engine recoil rope while forcing the belt over the edge of the engine pulley into the V-groove.
  - ★ install new forward belt:
    - place forward belt in transmission pulley groove.
    - gently pull the engine recoil rope to rotate the pulley while forcing the forward belt into the V-groove.
4. Replace belt guard.
5. Attach spark plug wire.

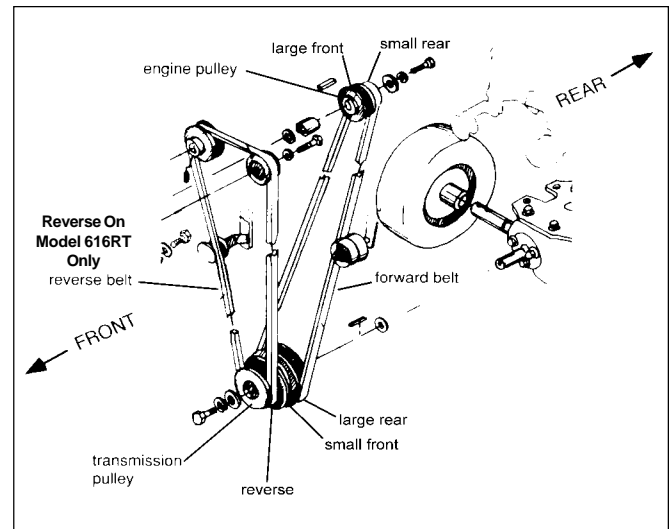

# Maintenance and Storage

## CHECK OR FILL ENGINE CRANKCASE

1. Add oil according to chart below. **Do not overfill.** Use a high quality detergent oil classified "For Service SF-SJ,". Use no special additives with recommended oils. Do not mix oil with gasoline.
2. Always check oil level before starting engine. Refer to engine manual for complete instructions.

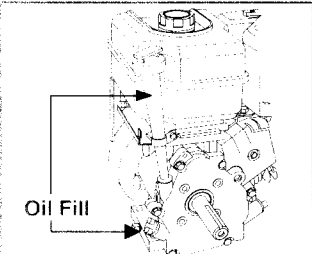

[1] Place engine level and clean around oil fill area.

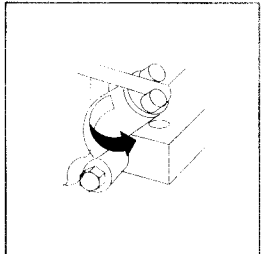

[2] Remove oil fill cap.

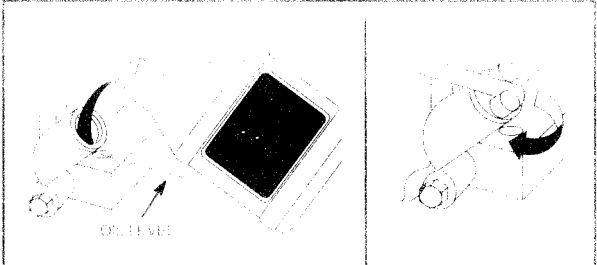

[3] Pour oil slowly. Fill to point of overflowing.  
[4] Replace and tighten oil fill cap

Adapted from Briggs & Stratton Corporation, Form No. 274263-10/99.

**IMPORTANT**

**Engine is shipped from factory without oil. You must add engine oil before starting engine.**

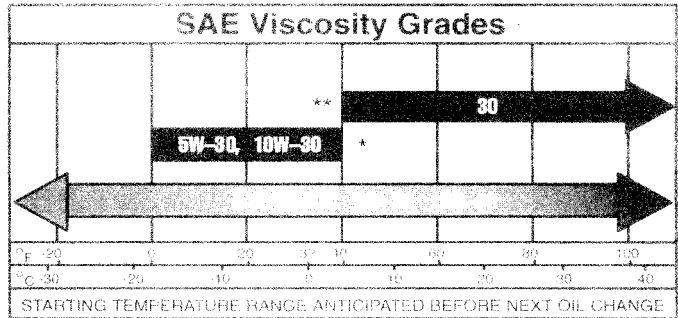

Adapted from Briggs & Stratton Corporation, Form No. 274263-10/99.

*\*Air cooled engines run hotter than automotive engines. Use of non-synthetic multi-viscosity oils (5W30, 10W-30, etc.) above 40° F (4° C) will result in high oil consumption and possible engine damage. Check oil level more frequently if using these types of oils.*

*\*\*SAE 30 oil, if used below 40° F (4° C), will result in hard starting and possible engine bore damage due to inadequate lubrication.*

## CHECK TILLER TRANSMISSION GREASE

**IMPORTANT**

**TILLER TRANSMISSION IS SHIPPED FROM FACTORY WITH THE PROPER AMOUNT OF 00 LIQUID GREASE.**

Check the grease level annually. To check the grease level:

1. Move tiller to level ground.
2. Remove grease level dipstick located on the front transmission cover. Correct 00 grease level is indicated between the high and low levels on the dipstick.
3. Replace grease level dipstick in the filler hole.
4. Note that the front wheel transmission and rear tine transmission are one common reservoir. When you add to the front transmission, you must wait a short period of time for the 00 grease to flow rearward and equalize in both front and rear. The dipstick will read correctly on level ground for both gear units.

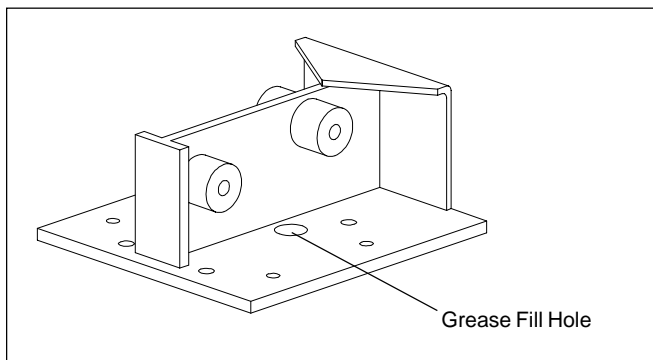

**IMPORTANT**

**When replacing grease, the tiller transmission holds 18-22 ounces. DO NOT OVERFILL.**

## CHECK TIRE PRESSURE

Recommended tire pressure is 20 PSI. If tires do not have equal pressure, tiller will pull to one side.

## LUBRICATION

Proper lubrication of moving mechanical parts of your rototiller is a very important part of care and maintenance. You should oil the moving parts shown at 10 hour intervals using a 30 weight oil.

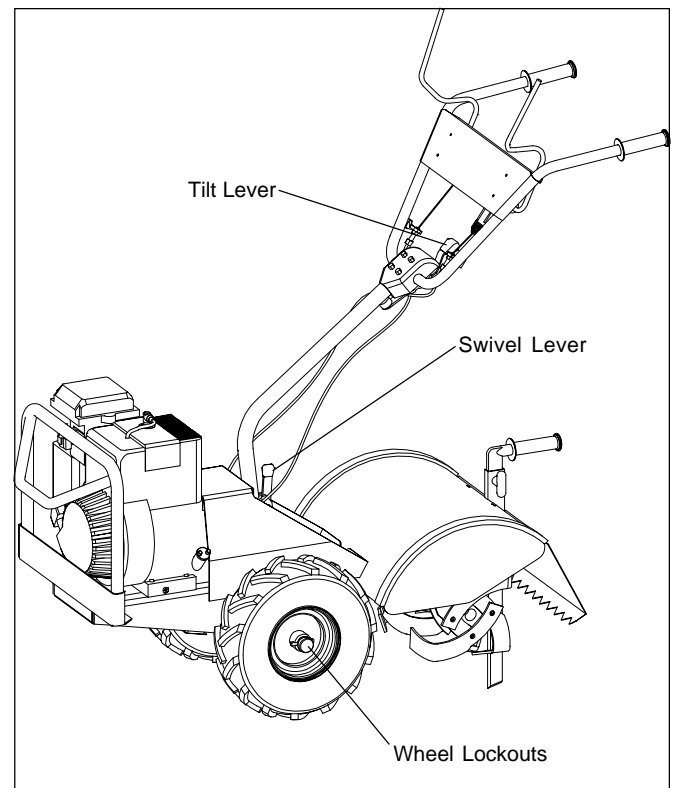

# Maintenance and Storage

---

## ENGINE MAINTENANCE

Refer to the engine manual included in your parts packet for information on engine maintenance. Your engine manual provides detailed information and a maintenance schedule for performing the following tasks:

1. Check oil level before each use or after every 8 hours of operation.
2. Change oil after first 5-8 hours of operation. Change oil while engine is warm. Refill with new oil of recommended grade.
4. Check spark plug yearly or every 100 hours of operation.
5. Service air cleaner.
6. Keep engine and parts clean.
7. Check engine and equipment often for loose nuts and bolts, keep these items tightened.

## CLEAN TINE AXLE SHAFT

1. Turn off engine. Engine must be cool.
2. Remove spark plug wire from spark plug.
3. Tip the tiller forward. Block the tiller in position so that it rests on the engine mount and the tines are exposed.
4. Remove all vegetation, string, wire, and other material that may have accumulated on the axle between the inside set of tines and the seal on the transmission housing.
5. Tip the tiller back to a level position.
6. Replace spark plug wire.



### CAUTION

Do not operate tiller before reading the engine manual provided in the parts packet.



### CAUTION

Temperature of muffler and near by areas may exceed 150° F. Avoid these areas.



Engine can overheat and become damaged if debris blocks the cooling system or rotating screen.



Never run engine without complete air cleaner installed on engine.



## PREPARE FOR STORAGE

Follow the steps below to prepare your tiller for storage. Read your engine manual for detailed instructions on preparing the engine for storage.

1. Protect wheels and axles from rust:
  - Loosen locking bolt inside wheel. Slide wheel toward machine.
  - Coat the axles lightly with axle grease.
  - Move wheel back into position and snug locking bolt. Back off locking bolt 1/16 turn and lock jam nut.
2. Run with gas stabilizer in fuel.
3. Drain the fuel tank. Run the engine until it stops.
4. While engine is still warm, drain the oil from the engine. Refill with fresh oil of the recommended grade.

5. Remove spark plug, pour one-half ounce of clean engine oil into cylinder. Pull starter handle slowly several times to distribute oil. Replace spark plug.
6. Clean entire tiller.
7. Store your tiller in a clean, dry building.



### CAUTION

Do not store tiller in an unventilated area where fuel fumes may reach flame, sparks, pilot lights or an ignited object. Drain fuel outdoors away from any ignition sources. Use only approved fuel containers.

## TILLER AND ENGINE MAINTENANCE SCHEDULE

Your tiller will require maintenance including service and adjustments before and after use. To help ensure long life and peak performance for your tiller, follow the maintenance schedule below. Refer to your Briggs & Stratton manual to establish a maintenance schedule for the engine.

Maintenance Operation	See Page #	Before Each Use	50 hrs or Every Season
Check forward belt tension _____	16	_____ ✓	
Check or fill engine crankcase _____	18	_____ ✓	
Check tiller transmission grease _____	19	_____ ✓	
Check tire pressure _____	19	_____ ✓	
Change forward/reverse belt _____	17	_____	_____ ✓
Clean tine axle shaft _____	20	_____	_____ ✓
Lube wheel axle shaft _____	21	_____	_____ ✓
Check throttle control adjustment _____	EM	_____	_____ 1
Change engine oil _____	EM	_____	_____ 2

EM = See engine manual.

**1** Adjust throttle control after first 3 hours of operation or if engine is hard to start or run-on occurs.

**2** Change oil after first 5-8 hours of use, then after every 50 hours or every season. Change oil every 25 hours when operating under heavy load or in high temperatures.

# Troubleshooting and Repair

## TROUBLESHOOTING GUIDE



### CAUTION

Practice safety at all times. Engine must be turned off and allowed to cool, and spark plug wire must be disconnected before attempting any maintenance or repair.

PROBLEM	REMEDY/ACTION
Engine will not start	<ol style="list-style-type: none"> <li>1. Connect spark plug wire to spark plug</li> <li>2. Throttle must be positioned at choke for a cold start (see page 8 for instructions)</li> </ol>
Engine runs rough, floods during operation	<ol style="list-style-type: none"> <li>1. Clean or replace air cleaner</li> </ol>
Engine is hard to start	<ol style="list-style-type: none"> <li>1. Drain old fuel and replace with fresh. Use gas stabilizer at end of season</li> <li>2. Make sure spark plug wire is securely attached to spark plug</li> <li>3. Drive control levers must be released to <b>neutral</b> to start the engine</li> </ol>
Engine misses or lacks power	<ol style="list-style-type: none"> <li>1. Raise the tines for shallower tilling by lowering the drag stake, see page 11</li> <li>2. Remove and clean fuel tank</li> <li>3. Clean or replace air cleaner</li> <li>4. Improper carburetor adjustment, take to authorized Briggs &amp; Stratton service center</li> <li>5. Replace spark plug and adjust gap</li> <li>6. Drain and refill gas tank and carburetor</li> </ol>
Engine will not stop when throttle control is positioned at stop	<ol style="list-style-type: none"> <li>1. See engine manual to check and adjust throttle linkage</li> </ol>
Tiller moves forward during starting	<ol style="list-style-type: none"> <li>1. Drive control levers must be released to <b>neutral</b> to start the engine</li> </ol>
Tiller is difficult to control when tilling (machine jumps or lurches forward)	<ol style="list-style-type: none"> <li>1. Lock wheels in tilling position, see page 9</li> <li>2. Raise the tines for shallower tilling by lowering the drag stake, see page 11</li> </ol>
Tines turn, wheels do not turn	<ol style="list-style-type: none"> <li>1. Lock wheels in tilling position, see page 9</li> <li>2. Internal transmission failure, see your dealer</li> </ol>
Tines turn, wheels turn, tiller does not move	<ol style="list-style-type: none"> <li>1. Lower the tines for deeper tilling by raising the drag stake, see page 11</li> </ol>

## Troubleshooting and Repair

<b>PROBLEM</b>	<b>REMEDY/ACTION</b>
<b>Belts squeal in neutral and/or reverse</b>	1. Adjust forward belt guide: <ul style="list-style-type: none"> <li>- turn engine off and allow muffler to cool</li> <li>- disconnect spark plug wire from spark plug</li> <li>- remove belt guard</li> <li>- pull down on drive control levers</li> <li>- manually bend forward belt guide so there is 1/16 inch or less clearance between belt guide and belt</li> <li>- replace belt guard and spark plug wire</li> </ul>
<b>Belts squeal in forward operation</b>	1. Adjust tabs on the reverse belt guide <ul style="list-style-type: none"> <li>- turn engine off and allow muffler to cool</li> <li>- disconnect spark plug wire from spark plug</li> <li>- release drive control levers to <b><i>neutral</i></b></li> <li>- remove belt guard</li> <li>- adjust tabs of reverse belt guide:               <ul style="list-style-type: none"> <li>while drive control levers are released, bend metal tabs on reverse belt guide to 1/64 inch or less clearance from reverse belt</li> </ul> </li> <li>- replace belt guard and spark plug wire</li> </ul>
<b>Excessive heat build up in transmission/tine area during tilling</b>	1. Remove vegetation by following instructions in Clean Tine Axle Shaft on page 20 of Maintenance & Storage section. FOLLOW ALL SAFETY INSTRUCTIONS  2. Check transmission fluid and fill if needed by following instructions on page 19

# Specifications

---

## FEATURES

- ☆ 6-HP Briggs & Stratton Engine (616RT)
- ☆ 5-HP Tecumseh Engine (514RT)
- ☆ Tractor Type Pneumatic Tires
- ☆ All Gear Drive Transmission
- ☆ Handlebar Height Adjustment
- ☆ Forward/Reverse Control (616RT)
- ☆ Functional Drag Stake System
- ☆ Wheel Lockout Control (616RT)
- ☆ Drive Safety Control Levers
- ☆ Self Cleaning Bolo Tines (616RT)
- ☆ Slasher Tines (514RT)
- ☆ Bumper Guard (616RT)
- ☆ Hiller-Furrower Attachment - Optional

---

## TECHNICAL MANUAL AVAILABILITY

Additional copies of this manual, as well as a fully illustrated Parts Manuals for your unit are available. The Parts Manuals show all of the assemblies and individual parts as exploded views which show the relationship of the parts and how they go together. Important assembly notes and special torque values are included in the illustrations. Standard hardware and torque specification charts are also included.



*To order copies of the manuals applicable to your model, contact the Simplicity Customer Publications Department at 414-284-8519.*



Have the following information on the form at the right available when phoning in your request.

Model: \_\_\_\_\_

M/N (Mfg. No.): \_\_\_\_\_

S/N (Serial #): \_\_\_\_\_

Your Name: \_\_\_\_\_

Address: \_\_\_\_\_

City, State, Zip: \_\_\_\_\_

Visa/Mastercard No.: \_\_\_\_\_

Card Expiration Date: \_\_\_\_\_